

RESISTORS

The colored bands around the body of a color coded resistor represent its value in ohms. These colored bands are grouped toward one end of the resistor body. Starting with this end of the resistor, the first band represents the first digit of the resistance value; the second band represents the second digit; the third band represents the number by which the first two digits are multiplied. A fourth band of gold or silver represents a tolerance of $\pm 5\%$ or $\pm 10\%$ respectively. The absence of a fourth band indicates a tolerance of $\pm 20\%$.

The physical size of a composition resistor is related to its wattage rating. Size increases progressively as the wattage rating is increased. The diameters of 1/2 watt, 1 watt and 2 watt resistors are approximately 1/8", 1/4" and 5/16", respectively.

The color code chart and examples which follow provide the information required to identify color coded resistors.

CODE			
COLOR	1ST DIGIT	2ND DIGIT	MULTIPLIER
BLACK	0	0	1
BROWN	1	1	10
RED	2	2	100
ORANGE	3	3	1,000
YELLOW	4	4	10,000
GREEN	5	5	100,000
BLUE	6	6	1,000,000
VIOLET	7	7	10,000,000
GRAY	8	8	100,000,000
WHITE	9	9	1,000,000,000
GOLD	-	-	.1
SILVER	-	-	.01

EXAMPLES

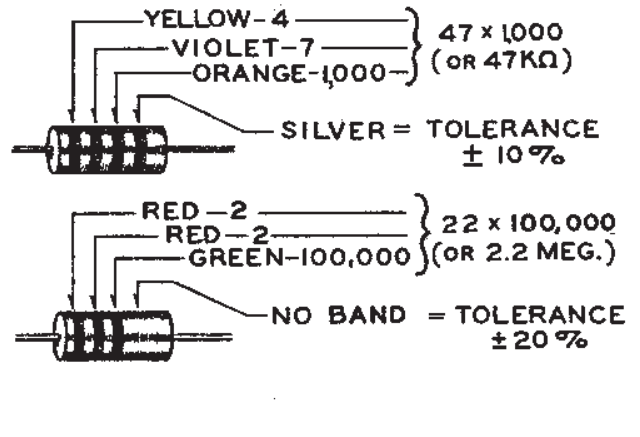

CAPACITORS

Generally, only mica and tubular ceramic capacitors, used in modern equipment, are color coded. The color codes differ somewhat among capacitor manufacturers, however the codes

shown below apply to practically all of the mica and tubular ceramic capacitors that are in common use. These codes comply with EIA (Electronics Industries Association) Standards.

MICA

CODE				
COLOR	1ST DIGIT	2ND DIGIT	MULTIPLIER	TOLER. %
BLACK	0	0	1	± 20
BROWN	1	1	10	± 20
RED	2	2	100	± 2
ORANGE	3	3	1,000	± 3
YELLOW	4	4	10,000	± 5
GREEN	5	5	---	---
BLUE	6	6	---	---
VIOLET	7	7	---	---
GRAY	8	8	---	---
WHITE	9	9	---	---
GOLD	-	-	.1	± 10
SILVER	-	-	.01	± 10

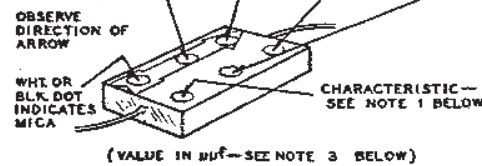
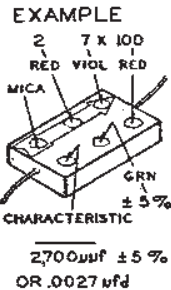

TUBULAR CERAMIC

Place the group of rings or dots to the left and read from left to right.

CODE				
COLOR	1ST DIGIT	2ND DIGIT	MULTIPLIER	TOLER. %
BLACK	0	0	1	± 25 ± 20
BROWN	1	1	10	± 0.1 ± 1
RED	2	2	100	± 2
ORANGE	3	3	1,000	± 2.5
YELLOW	4	4	10,000	---
GREEN	5	5	---	± 0.5 ± 5
BLUE	6	6	---	---
VIOLET	7	7	---	---
GRAY	8	8	---	± 0.25 ± 10
WHITE	9	9	---	---



NOTES:

1. The characteristic of a mica capacitor is the temperature coefficient, drift capacitance and insulation resistance. This information is not usually needed to identify a capacitor but, if desired, it can be obtained by referring to EIA Standard, RS-153 (a Standard of Electronic Industries Association.)

expressed in parts per million per degree centigrade. Refer to EIA Standard, RS-198 (a Standard of Electronic Industries Association.)

2. The temperature coefficient of a capacitor is the predictable change in capacitance with temperature change and is

3. The farad is the basic unit of capacitance, however capacitor values are generally expressed in terms of μf (microfarad, .000001 farad) and $\mu\mu\text{f}$ (micro-micro-farad, .000001 μf); therefore, 1,000 $\mu\mu\text{f}$ = .001 μf , 1,000,000 $\mu\mu\text{f}$ = 1 μf .

USING A PLASTIC NUT STARTER

A plastic nut starter offers a convenient method of starting the most used sizes: 3/16" and 1/4" (3-48 and 6-32). When the correct end is pushed down over a nut, the pliable tool conforms to the shape of the nut and the nut is gently held while it is being picked up and started on the screw. The tool should only be used to start the nut.



Assembly
and
Operation
of the



AMPLIFIER

MODEL AA-181

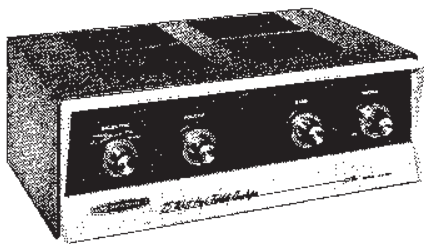

HEATH COMPANY,
BENTON HARBOR,
MICHIGAN



TABLE OF CONTENTS

Specifications.	2
Introduction.	4
Circuit Description.	4
Construction Notes.	5
Parts List.	6
Proper Soldering Techniques.	8
Schematic.	9*
Step-By-Step Procedure.	10
Step-By-Step Assembly.	11
Parts Mounting.	11
Wiring.	14
Component Installation.	18
Control Mounting And Front Panel Wiring.	21
Test And Adjustment.	26
Final Assembly.	27
Installation.	28
Operation.	29
In Case Of Difficulty.	29
Service Information.	30
Service.	30
Replacements.	32
Shipping Instructions.	32
Warranty.	32

*Fold-out from page.

All prices are subject to change without notice. The Heath Company reserves the right to discontinue instruments and to change specifications at any time without incurring any obligation to incorporate new features in instruments previously sold.



SPECIFICATIONS

Power Output.	25 watts.	
Music Power Rating.	30 watts.	
Peak Power.	50 watts.	
Frequency Response.	±1 db from 30 to 15,000 cps at 25 watts (using Auxiliary input).	
Input Sensitivity -		
Microphone.	9 millivolts rms for 25 watts output.	
Magnetic Phono.	5 millivolts rms for 25 watts output.	
Crystal Phono.12 volt rms for 25 watts output.	
Auxiliary.2 volt rms for 25 watts output.	
Input Impedances -		
Microphone.	1 megohm.	
Magnetic Phono.	47,000 Ω.	
Crystal Phono.	2.2 megohm.	
Auxiliary.	470,000 Ω.	
Output Impedances.	4, 8, and 16 Ω.	
Damping Factor.	9.	
Feedback.	20 db negative feedback at 1000 cps.	
Harmonic Distortion.	0.7% or less at 25 watts, 1000 cps. 2% or less at 25 watts, 30 and 15,000 cps.	
Intermodulation Distortion.	2% or less at 25 watts, 60 and 6000 cps, mixed 4:1.	
Hum And Noise -		
Microphone.	60 db or better.	} below 25 watts
Magnetic Phono.	53 db or better.	
Crystal Phono.	55 db or better.	
Auxiliary.	60 db or better.	

NOTE: Hum and noise measurements were made with the inputs shorted, the VOLUME control fully clockwise, and the tone controls in their flat positions. The Amplifier output was terminated with a 16 Ω resistive load.



Equalization.	RIAA for Magnetic Phono input.
Front Panel Controls -	
SELECTOR.	Four positions: MIC (Microphone). PHONO (Magnetic Phono). XTAL (Crystal Phono). AUX (Auxiliary).
BASS.	Provides approximately 17 db boost and 20 db cut at 30 cps.
TREBLE.	Provides approximately 13 db boost and 19 db cut at 20,000 cps; 13 db boost and 17 db cut at 15,000 cps. The AC ON-OFF switch is actuated at the extreme counterclockwise end of TREBLE control rotation.
Power Supply.	The transformer-operated power supply uses a full-wave rectifier. A hum balance control is used in the filament circuit to minimize hum. An unswitched AC outlet is provided on the rear of the chassis.
Power Requirements.	105 to 125 volts, 50/60 cps AC. 120 to 135 watts at 117 volts, with no load on AC outlet.
Tube And Diode Complement.	2 - 6EU7 Voltage amplifier. 1 - 12AU7/ECC81 Voltage amplifier and phase splitter. 2 - 7591 Power amplifier. 1 - 5AR4/GZ34 Full-wave rectifier. 1 - Selenium diode - Bias rectifier.
Dimensions.	13-1/2" wide x 4-15/16" high x 9-1/2" deep. NOTE: Feet are included in the height dimension.
Mounting.	A 4" x 12-5/8" opening is required for horizontal mounting in a vertical panel. Vertical mounting is not recommended.
Finish.	Ivory and charcoal gray.
Net Weight.	18 lbs.
Shipping Weight.	21 lbs.



INTRODUCTION

The HEATHKIT Model AA-181 Amplifier is designed to offer the maximum in performance, versatility, and utility at the lowest possible cost. To this end, several features have been incorporated which are unusual in an amplifier in this price range.

Four separate inputs are provided, any one of which may be selected with the front panel SELECTOR switch. The Magnetic Phono input is RIAA equalized. Sufficient amplification is available to drive the Amplifier with most of the low-level phono pickups or microphones now available. The Auxiliary input can be used

for a tuner or the output of a tape recorder. A range of output impedances makes it possible to match the Amplifier to most of the popular high-fidelity or public-address speaker systems commonly used.

The styling is a pleasing, low silhouette, ideal for limited-space installations or shelf mounting; or the Amplifier may be panel mounted after removing its wraparound cabinet shell.

Its durable enamel finish of neutral colors permits the Amplifier to blend in with almost any decor.

CIRCUIT DESCRIPTION

The AA-181 Amplifier has three basic sections; the magnetic phono preamplifier, the main amplifier, and the power supply. Each section will be discussed separately.

For explanation purposes, assume that the SELECTOR switch is in the PHONO position as shown on the Schematic Diagram. Refer to both the Schematic and Block Diagrams (fold-out from Page 9) to follow the circuit and identify circuit components while reading this description.

MAGNETIC PHONO PREAMPLIFIER

The audio signal presented to the PHONO input is applied directly to the grid of tube V1A, which is a high-gain, low-noise preamplifier stage. The amplified signal is coupled from the plate of V1A through capacitor C2 to the SELECTOR switch. Resistors R9 and R10, along with capacitors C3 and C4, provide R1AA equalization for the magnetic phono signal.

MAIN AMPLIFIER

The amplified magnetic phono signal and signals from the other inputs are all applied to the SELECTOR switch. The input signal chosen with the SELECTOR switch is applied through capacitor C5 to high-gain amplifier stage V1B. All other input signals are shorted to ground.

From the plate of V1B, the amplified signal is coupled through capacitor C6, VOLUME control R14, and C7 to the grid of V2A. After V2A, the signal is fed through capacitor C8 to the packaged electronic tone control network. This network is used with the BASS and TREBLE controls.

Next the signal is amplified further by stages V2B and V3A; then it is applied to phase splitter V3B. V3B does not amplify, but instead applies the signal in the proper phase through capacitor C16 to the grid of V4, and through C17 to the grid of V5. V4 and V5 operate as a pentode push-pull power amplifier output stage. The output of this stage is coupled through the output transformer to the speaker system.

POWER SUPPLY

The power supply uses a full-wave tube rectifier. The filter network, consisting of capacitors C19, C20, C21, C22, and C23 plus resistors R36, R37, R38, and R39, removes 120 cycle ripple from the B+ voltage. The selenium diode with resistors R40 and R41 plus capacitor C25 develops negative DC bias voltage for output tubes V4 and V5. Hum balance control R42, in the filament circuit, is adjustable for minimum hum.

CONSTRUCTION NOTES

This manual is supplied to assist you in every way to complete your kit with the least possible chance for error. The arrangement shown is the result of extensive experimentation and trial. If followed carefully, the result will be a stable instrument, operating at a high degree of dependability. We suggest that you retain the manual in your files for future reference, both in the use of the instrument and for its maintenance.

UNPACK THE KIT CAREFULLY AND CHECK EACH PART AGAINST THE PARTS LIST. In so doing, you will become acquainted with the parts. Refer to the charts and other information on the inside covers of the manual to help you identify the components. If some shortage or parts damage is found in checking the Parts List, please read the Replacement section and supply the information called for therein. Include all inspection slips in your letter to us.

Resistors generally have a tolerance rating of

10% unless otherwise stated in the Parts List. Tolerances on capacitors are generally even greater. Limits of +100% and -20% are common for electrolytic capacitors.

We suggest that you do the following before work is started:

1. Lay out all parts so that they are readily available.
2. Provide yourself with good quality tools. Basic tool requirements consist of a screwdriver with a 1/4" blade; a small screwdriver with a 1/8" blade; long-nose pliers; wire cutters, preferably separate diagonal cutters; a pen knife or a tool for stripping insulation from wires; a soldering iron (or gun) and rosin core solder. A set of nut drivers and a nut starter, while not necessary, will aid extensively in construction of the kit.

Most kit builders find it helpful to separate the various parts into convenient categories. Muffin tins or molded egg cartons make convenient trays for small parts. Resistors and capacitors may be placed with their lead ends inserted in the edge of a piece of corrugated cardboard until they are needed. Values can be written on the cardboard next to each component. The illustration shows one method that may be used.

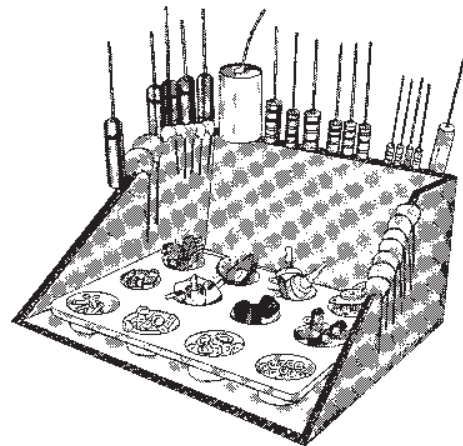

PARTS LIST

PART No.	PARTS Per Kit	DESCRIPTION	PART No.	PARTS Per Kit	DESCRIPTION
<u>Resistors</u>			<u>Capacitors</u>		
① 1-7	1	680 Ω 1/2 watt (blue-gray-brown)	⑤ 20-76	1	68 μmf mica
1-9	5	1000 Ω 1/2 watt (brown-black-red)	20-107	1	680 μmf mica
1-44	3	2200 Ω 1/2 watt (red-red-red)	⑥ 21-3	1	10 μmf disc ceramic
1-69	1	18 KΩ 1/2 watt (brown-gray-orange)	21-46	1	.005 μfd disc ceramic
1-22	2	22 KΩ 1/2 watt (red-red-orange)	⑦ 23-2	1	.005 μfd 400 or 600 V tubular
1-25	2	47 KΩ 1/2 watt (yellow-violet-orange)	23-28	2	.1 μfd 200 V tubular
1-26	3	100 KΩ 1/2 watt (brown-black-yellow)	23-42	1	.015 μfd 600 V tubular
1-29	2	220 KΩ 1/2 watt (red-red-yellow)	23-52	6	.047 μfd 400 V tubular
1-31	1	330 KΩ 1/2 watt (orange-orange-yellow)	⑧ 25-19	1	20 μfd 150 V electrolytic
1-33	3	470 KΩ 1/2 watt (yellow-violet-yellow)	⑨ 25-101	1	60 μfd at 500 V and 25 μfd at 450 V electrolytic
1-35	4	1 megohm 1/2 watt (brown-black-green)	25-109	1	40-40-30-40 μfd at 400-350- 250-150 V electrolytic
1-37	1	2.2 megohm 1/2 watt (red-red-green)			
1-114	1	8200 Ω 1/2 watt 5% (gray-red-red-gold)			
1-122	1	3300 Ω 1/2 watt 5% (orange-orange-red-gold)			
② 4-2	1	100 KΩ 1/2 watt low-noise (brown-black-yellow)			
③ 1A-2	1	1000 Ω 1 watt (brown-black-red)			
1A-26	1	15 KΩ 1 watt (brown-green-orange)			
1A-5	3	22 KΩ 1 watt (two matched)* (red-red-orange)			
1A-28	1	100 KΩ 1 watt (brown-black-yellow)			
④ 3E-9	1	3000 Ω 5 watt wire-wound			

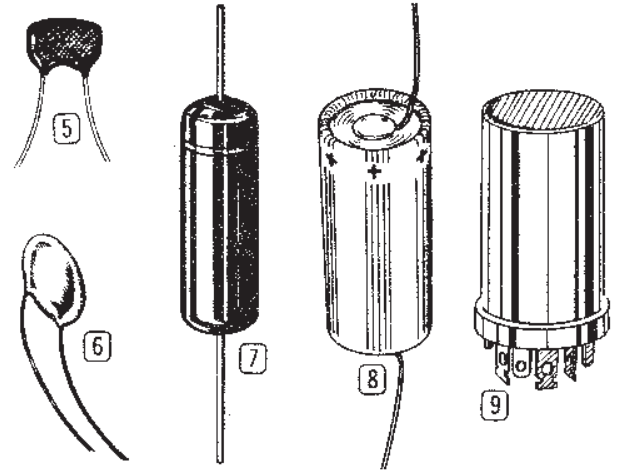

Controls-Switches

⑩ 10-52	1	2000 Ω control (2 KΩ)
⑪ 10-64	1	1 megohm control (BASS)
10-86	1	1 megohm control (VOLUME)
⑫ 19-37	1	1 megohm control with SPST switch (TREBLE)
63-270	1	4-position rotary switch

*Keep in bag until called for in the steps.

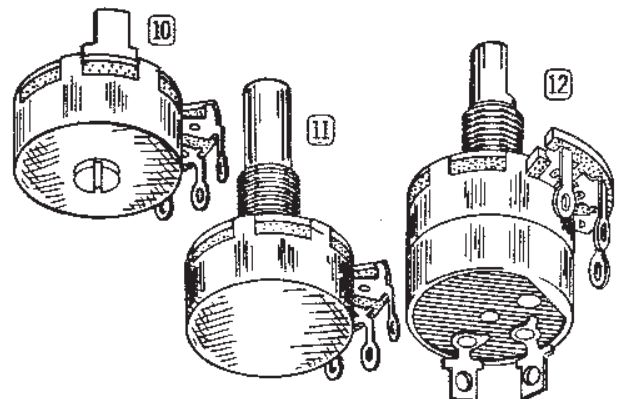
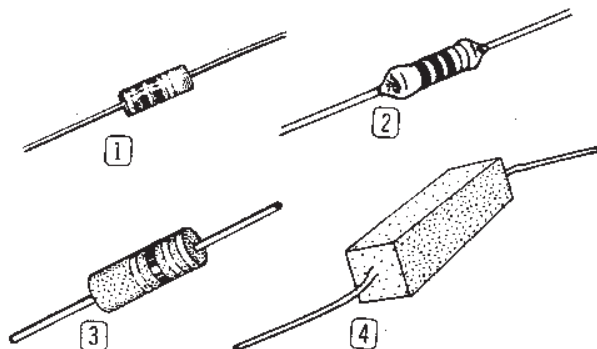

PART No.	PARTS Per Kit	DESCRIPTION
----------	---------------	-------------

Transformers-Diode-Tubes

51-82	1	Output transformer
54-118	1	Power transformer
① 57-22	1	Selenium diode
411-25	1	12AU7/ECC81 tube
411-136	1	GZ34/5AR4 tube
411-138	2	7591 tube
411-143	2	6EU7 tube



Terminal Strips-Sockets

② 431-2	2	2-lug terminal strip with #6 mounting hole
431-3	1	3-lug terminal strip with #6 mounting hole
431-5	3	4-lug terminal strip with #6 mounting hole
③ 431-13	1	4-lug screw type terminal strip
④ 431-32	1	2-lug terminal strip with #8 mounting hole
431-33	1	3-lug terminal strip with #8 mounting hole
434-2	3	Octal tube socket
434-16	3	Wafer tube socket
434-20	1	AC socket
⑤ 434-76	1	Triple phono socket
⑥ 436-4	1	Phone jack
481-1	1	Capacitor mounting wafer (metal)
481-3	1	Capacitor mounting wafer (fiber)

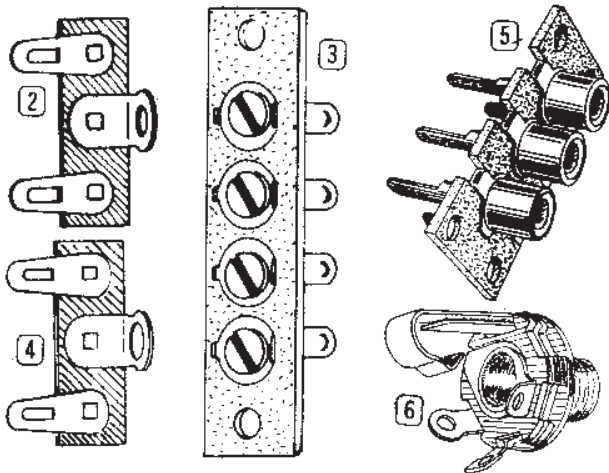

PART No.	PARTS Per Kit	DESCRIPTION
----------	---------------	-------------

Metal Parts

90-M173F	1	Cabinet shell
200-M300F502	1	Chassis
203-M247F503	1	Front panel
203-M248F504-505	1	Trim strip
205-M306	1	Bottom plate
210-16F	1	Bezel

Hardware

⑦ 250-49	6	3-48 x 1/4" screw
⑧ 250-32	6	6-32 x 3/8" screw (flat head)
⑨ 250-26	4	6-32 x 5/8" screw
⑩ 250-89	9	6-32 x 3/8" screw



⑪ 250-56	11	6-32 x 1/4" screw
⑫ 250-8	7	#6 sheet metal screw
⑬ 252-1	6	3-48 nut
⑭ 252-3	34	6-32 nut



⑮ 252-4	8	8-32 nut
⑯ 252-7	5	Control nut
⑰ 252-32	1	Push-on speednut
⑱ 253-10	5	Flat washer



⑲ 254-1	40	#6 lockwasher
⑳ 254-2	10	#8 lockwasher
㉑ 254-4	4	Control lockwasher
㉒ 255-2	4	#6 x 3/16" spacer
㉓ 255-3	4	#6 x 3/8" spacer

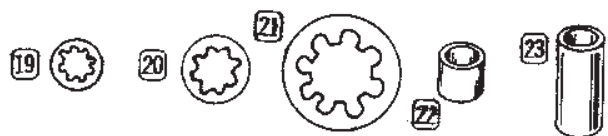

Wire-Sleeving

89-1	1	Line cord
343-6	1	Length shielded cable
344-1	1	Length hookup wire
346-1	1	Length insulating sleeving, black
346-2	1	Length insulating sleeving, clear

PART No.	PARTS Per Kit	DESCRIPTION
<u>Miscellaneous</u>		
73-4	2	Rubber grommet
① 75-24	1	Line cord strain relief
② 75-41	1	Triple phono socket insulator
③ 84-13	1	P.E.C. tone control network
206-3	1	Tube shield
④ 206-55	1	Tube base shield
261-17	4	Plastic feet
412-13	1	Neon pilot lamp
421-25	1	Fuse, 1-1/2 ampere slow-blow
423-1	1	Fuse holder
⑤ 438-4	4	Phono plug
462-124	4	Knob
331-6		Solder
595-442	1	Manual

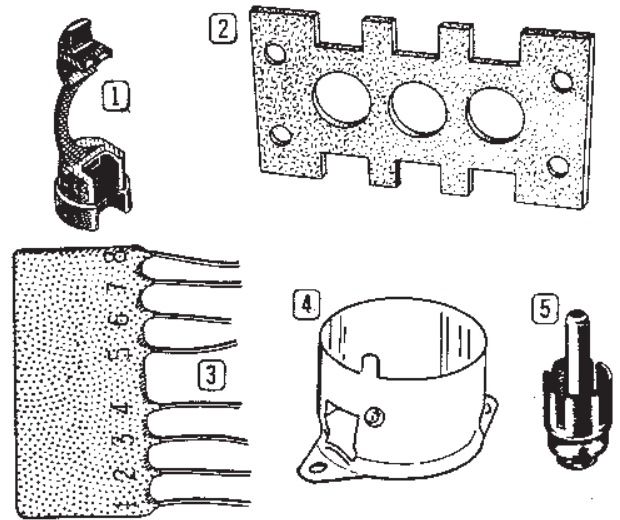

PROPER SOLDERING TECHNIQUES

Only a small percentage of HEATHKIT equipment purchasers find it necessary to return an instrument for factory service. Of these instruments, by far the largest portion of malfunctions are due to poor or improper soldering.

If terminals are bright and clean and free of wax, frayed insulation and other foreign substances, no difficulty will be experienced in soldering. Correctly soldered connections are essential if the performance engineered into a kit is to be fully realized. If you are a beginner with no experience in soldering, a half hour's practice with some odd lengths of wire may be a worthwhile investment.

For most wiring, a 25 to 100 watt iron or its equivalent in a soldering gun is very satisfactory. A lower wattage iron than this may not heat the connection enough to flow the solder smoothly over the joint. Keep the iron tip clean and bright by wiping it from time to time with a cloth.

CHASSIS WIRING AND SOLDERING

1. Unless otherwise indicated, all wire used is the type with colored insulation (hookup wire); the size of the conductor is the same for all colors of hookup wires furnished with this kit. In preparing a length of hookup wire, 1/4" of insulation should be removed from each end unless directed otherwise in the construction step.
2. To avoid breaking internal connections when stripping insulation from the leads of transformers or similar components, care should be taken not to pull directly on the lead. Instead, hold the lead with pliers while it is being stripped.
3. Leads on resistors, capacitors and similar components are generally much longer than they need to be to make the required connections. In these cases, the leads should be



cut to proper length before the part is added to the chassis. In general, the leads should be just long enough to reach their terminating points.

4. Wherever there is a possibility of bare leads shorting to other parts or to the chassis, the leads should be covered with insulating sleeving. Where the use of sleeving is specifically intended, the phrase "use sleeving" is included in the associated construction step. In any case where there is the possibility of an unintentional short circuit, sleeving should be used. Extra sleeving is provided for this purpose.
5. Crimp or bend the lead (or leads) around the terminal to form a good joint without relying on solder for physical strength. If the wire is too large to allow bending or if the step states that the wire is not to be crimped, position the wire so that a good solder connection can still be made.
6. Position the work, if possible, so that gravity will help to keep the solder where you want it.

7. Place a flat side of the soldering iron tip against the joint to be soldered until it is heated sufficiently to melt the solder.
8. Then place the solder against the heated terminal and it will immediately flow over the joint; use only enough solder to thoroughly wet the junction. It is usually not necessary to fill the entire hole in the terminal with solder.
9. Remove the solder and then the iron from the completed junction. Use care not to move the leads until the solder is solidified.

A poor or cold solder joint will usually look crystalline and have a grainy texture, or the solder will stand up in a blob and will not have adhered to the joint. Such joints should be reheated until the solder flows smoothly over the entire junction. In some cases, it may be necessary to add a little more solder to achieve a smooth bright appearance.

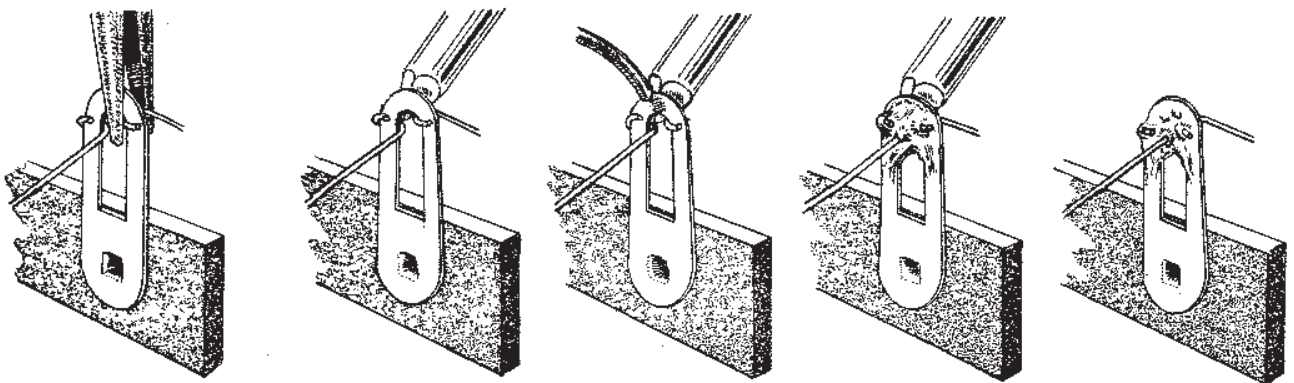

CRIMP WIRES HEAT CONNECTION APPLY SOLDER ALLOW SOLDER TO FLOW PROPER SOLDER CONNECTION

ROSIN CORE SOLDER HAS BEEN SUPPLIED WITH THIS KIT. THIS TYPE OF SOLDER MUST BE USED FOR ALL SOLDERING IN THIS KIT. ALL GUARANTEES ARE VOIDED AND WE WILL NOT REPAIR OR SERVICE EQUIPMENT IN WHICH ACID CORE SOLDER OR PASTE FLUXES HAVE BEEN USED. IF ADDITIONAL SOLDER IS NEEDED, BE SURE TO PURCHASE ROSIN CORE (60:40 or 50:50 TIN-LEAD CONTENT) RADIO TYPE SOLDER.



STEP-BY-STEP PROCEDURE

The following instructions are presented in a logical step-by-step sequence to enable you to complete your kit with the least possible confusion. Be sure to read each step all the way through before beginning the specified operation. Also read several steps ahead of the actual step being performed. This will familiarize you with the relationship of the subsequent operations. When the step is completed, check it off in the space provided. This is particularly important as it may prevent errors or omissions, especially if your work is interrupted. Some kit builders have also found it helpful to mark each lead in colored pencil on the Pictorial as it is added.

The fold-out diagrams in this manual may be removed and attached to the wall above your working area; but, because they are an integral part of the instructions, they should be returned to the manual after the kit is completed.

In general, the illustrations in this manual correspond to the actual configuration of the kit; however, in some instances the illustra-

tions may be slightly distorted to facilitate clearly showing all of the parts.

The abbreviation "NS" indicates that a connection should not be soldered yet as other wires will be added. When the last wire is installed, the terminal should be soldered and the abbreviation "S" is used to indicate this. Note that a number will appear after each solder instruction. This number indicates the number of leads that are supposed to be connected to the terminal in point before it is soldered. For example, if the instruction reads, "Connect a lead to lug 1 (S-2)," it will be understood that there will be two leads connected to the terminal at the time it is soldered. (In cases where a lead passes through a terminal or lug and then connects to another point, it will count as two leads, one entering and one leaving the terminal.)

The steps directing the installation of resistors include color codes to help identify the parts. Also, if a part is identified by a letter-number designation on the Schematic, its designation will appear at the beginning of the construction step which directs its installation.

STEP-BY-STEP ASSEMBLY

PARTS MOUNTING

Refer to Pictorial 1 for the following steps.

- () Locate the chassis and position as shown in Pictorial 1.
- () Install a rubber grommet in chassis hole J.
- () Similarly, install the remaining grommet at M.

NOTE: The phrase "#6 hardware" means 6-32 x 1/4" screws, #6 lockwashers, and 6-32 nuts.

- () Mount the AC socket at A. Use #6 hardware as shown in Detail 1A. This socket should be mounted from inside the rear chassis flange.

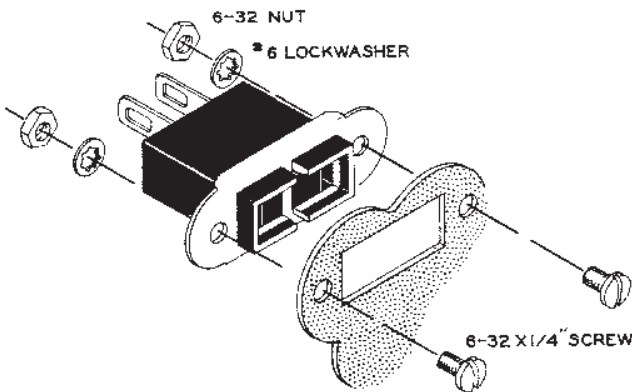

Detail 1A

- () Referring to Detail 1B, mount the fuse holder at B. Use the hardware furnished with the fuse holder. Position as shown in Pictorial 1.

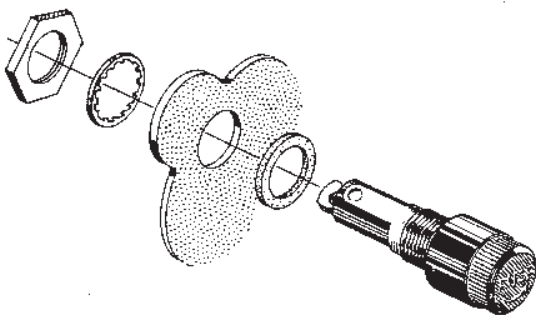

Detail 1B

- () From outside the rear chassis flange, mount the 4-lug screw type terminal strip at C. Use #6 hardware as shown in Detail 1C. Position the terminal strip with its lugs as shown in Pictorial 1.

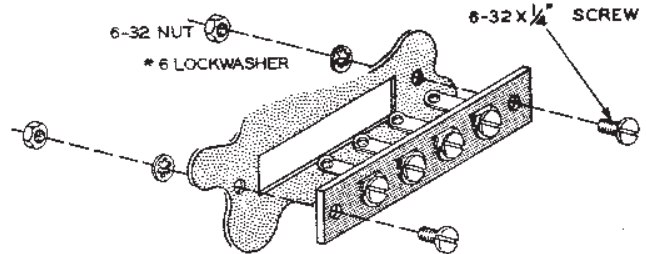

Detail 1C

- () Mount the triple phono socket at D. Make sure the insulator is between the chassis and the socket. Use 6-32 x 3/8" screws, #6 lockwashers, and 6-32 nuts as shown in Detail 1D. **NOTE:** Do not use the 6-32 x 3/8" flat head screws.

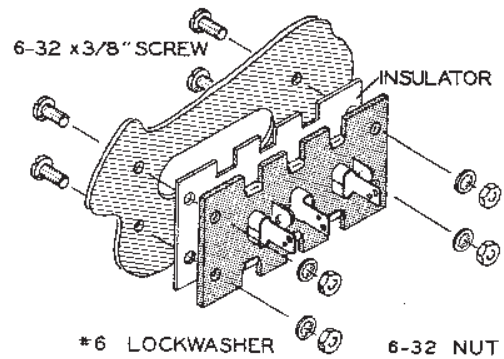

Detail 1D

- () Install the phone jack at E. Use a control lockwasher, flat washer, and control nut as shown in Detail 1E. Position as shown in Pictorial 1.

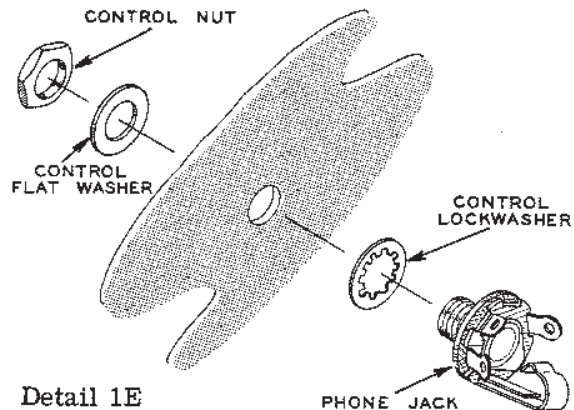

Detail 1E

- () Mount an octal tube socket at V4. Use 6-32 x 3/8" flat head screws, #6 lockwashers, and 6-32 nuts as shown in Detail 1F. Make sure the socket is mounted from the bottom of the chassis and that the keyway is oriented as indicated by the arrow in Pictorial 1.

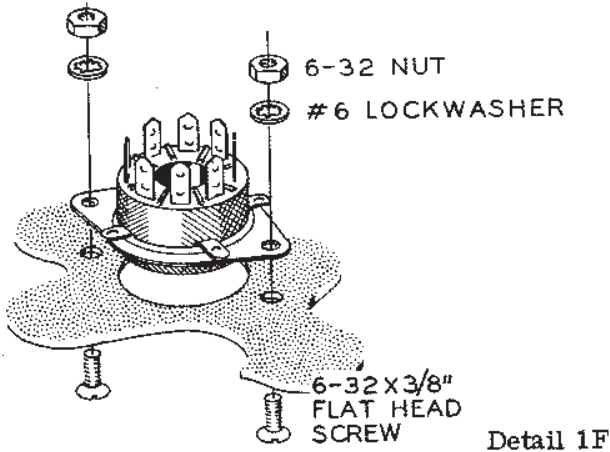

- () Similarly, mount octal tube sockets at V5 and V6.

- () Mount a wafer tube socket at V2 with 3-48 screws and nuts as shown in Detail 1G. Make sure the blank space is oriented as indicated by the arrow in Pictorial 1.

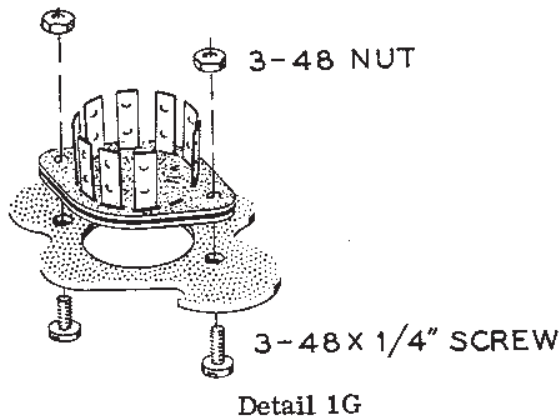

- () Similarly, mount a wafer tube socket at V3.
- () Mount a wafer tube socket with tube base shield at V1. Use 3-48 screws and nuts, as shown in Detail 1H.

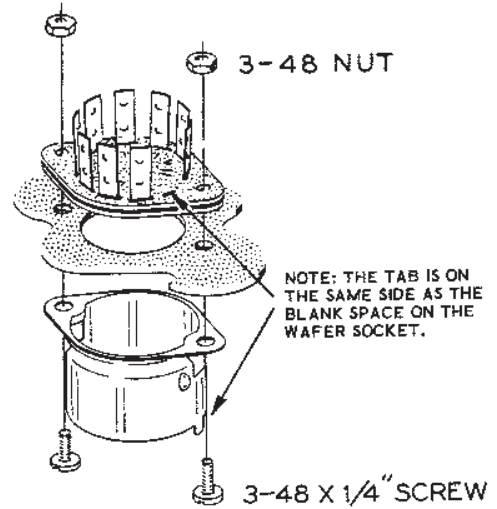

Detail 1H

- () Referring to Detail 1J, mount a 2-lug terminal strip (#6 mounting hole) at AA. Use #6 hardware.

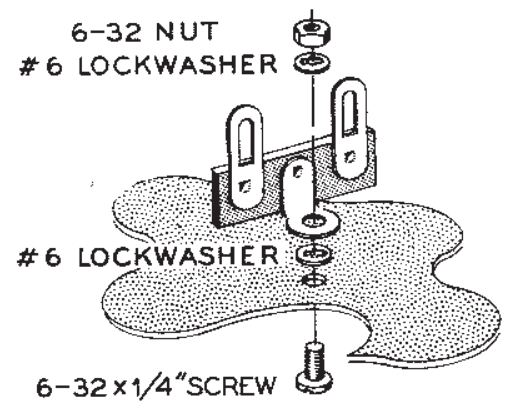

Detail 1J

- () Similarly, mount a 2-lug terminal strip (#6 mounting hole) at DD.
- () Mount 4-lug terminal strips at BB and CC.
- () Referring to Detail 1K, mount 4-lug terminal strip EE and with the same screw, mount a 3-lug terminal strip with a #6 mounting hole at FF on the chassis. Use a 6-32 x 3/8" screw, three #6 lockwashers, and a 6-32 nut. Refer forward to Pictorial 4 for the position of terminal strip FF.

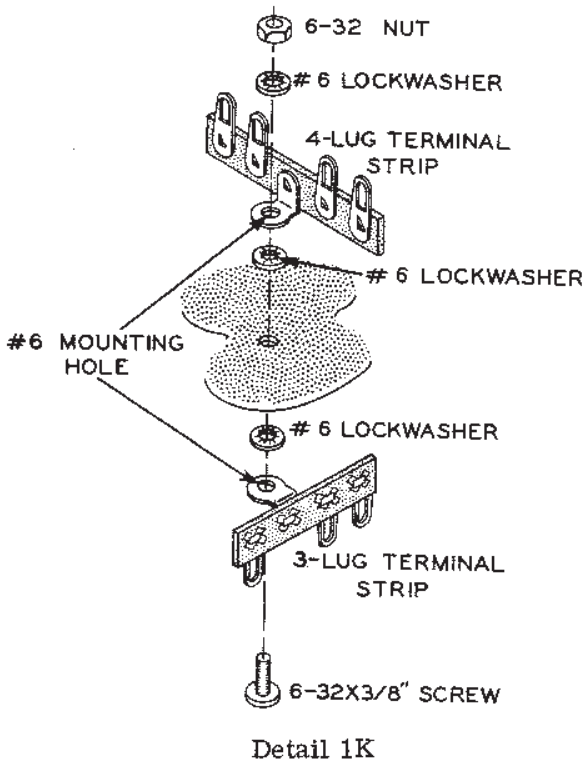

- () R42. Mount the 2000 Ω control (#10-52) at H as shown in Detail 1L. Position as shown in Pictorial 1.

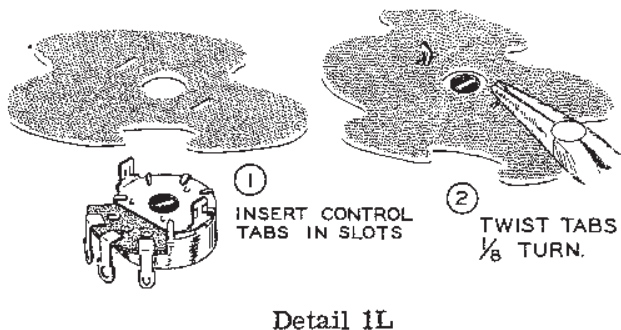

- () Using 6-32 x 5/8" screws, #6 lockwashers, 6-32 nuts, and 3/8" spacers, mount a metal capacitor mounting wafer at F. See Detail 1M.
- () Similarly, mount a fiber capacitor mounting wafer at G.
- () C19 and C20. Install the 60-25 μ fd can-type electrolytic capacitor (#25-101) in the metal capacitor mounting wafer at F. Orient the lugs as shown by the lug markings in Pictorial 1 and secure by twisting each mounting lug 1/8 turn with long-nose pliers.

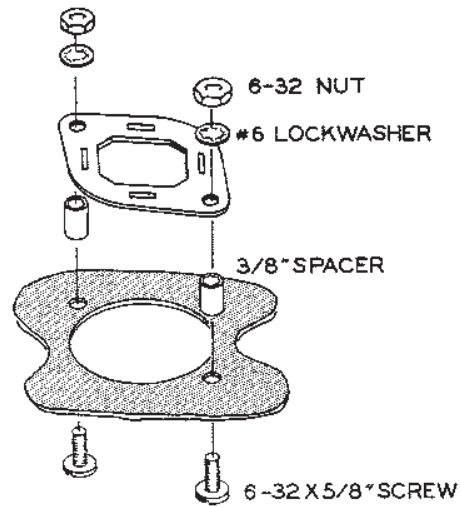

Detail 1M

- () C21, C22, C23, and C24. Install the 40-40-30-40 μ fd can-type electrolytic capacitor (#25-109) in the fiber capacitor mounting wafer at G. Orient the lugs as shown in Pictorial 1. Secure by twisting each mounting lug 1/8 turn with long-nose pliers.

Cut the leads of the output transformer (#51-82) to the following lengths:

LEAD COLOR	LENGTH
<u>Primary</u>	
() Red	6-1/4"
() Blue	5"
() Blue-yellow	3-1/2"
<u>Secondary</u>	
() Yellow	5"
() Orange	4-3/4"
() Brown	4-1/2"
() Black	4-1/2"
() Strip 1/4" insulation from the end of each output transformer lead and tin, ("Tin" means to melt a small amount of solder on the exposed lead end.)	

- () Mount the output transformer with its leads placed as indicated in Pictorial 1. Use six #8 lockwashers and four 8-32 nuts. Mount the remaining 2-lug terminal strip at GG and the remaining 3-lug terminal strip at HH. Use a lockwasher below and above each terminal strip mounting foot.

Cut the leads of the power transformer (#54-118) to the following lengths:

<u>LEAD COLOR</u>	<u>LENGTH</u>
() Red-yellow	2"
() Either yellow	4-1/4"
() Other yellow	3-1/2"
() Either red	3-1/2"
() Other red	2-3/4"
() Either black	3-1/2"
() Other black	2-1/2"
() Either brown	4-3/4"
() Other brown	4-3/4"

NOTE: Do not cut the red-green lead.

- () Strip 1/4" insulation from the end of each power transformer lead and tin.
- () Mount the power transformer with its leads placed as indicated in Pictorial 1. Use four #8 lockwashers and four 8-32 nuts.

WIRING

Refer to Pictorial 2 (fold-out from Page 17) for the following steps.

Connect the output transformer leads as follows:

<u>LEAD COLOR</u>	<u>CONNECT TO</u>
<u>Primary</u>	
() Red	lug 1 of filter capacitor F (NS).
() Blue	lug 3 of tube socket V5 (S-1).
() Blue-yellow	lug 3 of tube socket V4 (S-1).
<u>Secondary</u>	
() Yellow	lug 4 of terminal strip C (NS).
() Orange	lug 3 of terminal strip C (S-1).
() Brown	lug 2 of terminal strip C (S-1).
() Black	lug 1 of terminal strip C (NS).
() Twist the two yellow power transformer leads together. Connect the shorter lead to lug 2 (S-1) and the longer lead to lug 8 (NS) of tube socket V6.	
() Twist the two red power transformer leads together. Connect the shorter lead to lug 4 (S-1) and the longer lead to lug 6 (S-1) of tube socket V6.	

- () Twist the two black power transformer leads together and connect the longest lead to lug 2 of the AC socket A (NS). Connect the remaining black lead to lug 2 of fuse holder B (S-1).
- () Twist the two brown power transformer leads together. Connect either lead to lug 1 (NS) and the other lead to lug 3 (NS) of control H.
- () Connect the red-yellow transformer lead to lug 5 of filter capacitor F (S-1). Apply enough solder and heat so the lug is also soldered to the capacitor mounting wafer.
- () Route the red-green power transformer lead as shown in Pictorial 2 and connect it to lug 3 of terminal strip HH (NS).

NOTE: The purpose of using twisted pairs of hookup wire is to provide cancellation of hum in the filament circuit. Best results will be obtained in the following steps if the wires are twisted approximately three complete turns per inch. The wires may be twisted by hand or with a drill. (See Detail 2A.) If a drill is used, be careful not to twist the wires too tightly.

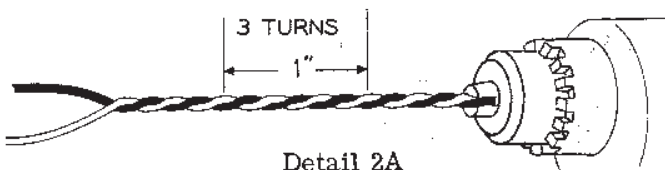

- () Cut two 45" lengths of hookup wire. Twist these wires together, using either method mentioned in the preceding note.

NOTE: When preparing lengths of twisted hookup wire, unwind only enough wire at each end to reach the terminating points called out in the steps. Strip 1/4" of insulation from both ends of each wire, then make the connections that are directed in the steps. Dress the twisted wires against the chassis.

- () At one end of a 6-1/2" twisted pair, connect either wire to lug 7 (NS) and the other wire to lug 2 (NS) of tube socket V4.
- () Dress this twisted pair under the transformer leads and at the other end, connect either wire to lug 1 (NS) and the other wire to lug 2 (NS) of tube socket V1.

- () At one end of a 4-1/2" twisted pair, connect either wire to lug 2 (S-2) and the other wire to lug 1 (S-2) of tube socket V1.
- () At the other end, connect either wire to lug 1 (NS) and the other wire to lug 2 (NS) of tube socket V2.
- () At one end of a 5-3/4" twisted pair, connect either wire to lug 2 (S-2) and the other wire to lug 1 (S-2) of tube socket V2.
- () At the other end, connect either wire to lug 9 (NS) and the other wire to lug 4 (NS) of tube socket V3.
- () At one end of a 3-3/4" twisted pair, strip 3/4" insulation from one wire. Insert this end through lug 4 (NS) to lug 5 (S-1) of tube socket V3. Now solder lug 4 (S-3).
- () Connect the other wire to lug 9 of tube socket V3 (S-2).
- () At the other end of this twisted pair, connect either wire to lug 1 (S-2) and the other wire to lug 3 (S-2) of control H.
- () At one end of a 13-1/2" twisted pair, connect either wire to lug 1 of the fuse holder (S-1) and the other wire to lug 1 of AC socket A (NS). Position the twisted pair as shown in Pictorial 2 and insert the other end through grommet J to be connected later.

NOTE: In the following steps, cut hookup wires to the specified lengths, strip 1/4" of insulation from each end and then make the connections.

- () Connect a 12-1/2" wire from lug 4 of terminal strip C (S-2) to lug 1 of terminal strip BB (NS). Position this wire as shown in Pictorial 2.
- () Strip 3/4" insulation from one end of a 2-1/4" wire. Insert this end through ground lug 9 (NS) to lug 5 (S-1) of tube socket V5. Now solder lug 9 (S-2).
- () Connect the other end of this wire to lug 1 of terminal strip C (S-2).

- () Remove the insulation from a 3/4" wire and connect the wire from ground lug 9 (S-1) to lug 5 (S-1) of tube socket V4.
- () Connect a 3" wire from lug 8 of tube socket V6 (S-2) to lug 1 of filter capacitor F (NS).
- () Connect a 5-1/2" wire from lug 4 of tube socket V5 (NS) to lug 2 of filter capacitor F (NS). Position this wire as shown in Pictorial 2.
- () Connect a 3-1/4" wire from lug 7 of tube socket V5 (S-1) to lug 7 of tube socket V4 (S-2).
- () Strip 1" insulation from both ends of a 4" wire. Insert one end through lug 8 (NS) to lug 4 (S-2) of tube socket V5. Now solder lug 8 (S-2).
- () Insert the other end of this wire through lug 4 (NS) to lug 8 (S-1) of tube socket V4. Now solder lug 4 (S-2).
- () Connect a 3-1/4" wire from lug 2 of tube socket V5 (S-1) to lug 2 of tube socket V4 (S-2).
- () Connect a 6-1/2" wire from lug 1 of terminal strip GG (NS) to lug 3 of tube socket V3 (NS). Position this wire under the transformer leads as shown in Pictorial 2.
- () Connect a 6-1/2" wire from lug 2 of terminal strip GG (NS) to lug 1 of tube socket V3 (NS).
- () Connect a 6-1/2" wire from lug 1 of filter capacitor G (NS) to lug 3 of terminal strip CC (NS).
- () Connect an 8-3/4" wire from lug 2 of filter capacitor G (NS) to lug 2 of terminal strip DD (NS).
- () Connect a 4-1/2" wire from lug 3 of filter capacitor G (S-1) to lug 2 of control H (NS).
- () Connect a 3" wire from lug 4 of filter capacitor G (NS) to lug 1 of terminal strip AA (NS).
- () Connect a 1-1/2" wire from lug 5 of filter capacitor G (S-1) to lug 2 of terminal strip AA (NS).
- () Connect a 4" wire from lug 2 of terminal strip AA (NS) to lug 2 of terminal strip BB (NS).
- () Connect a 4-3/4" wire from lug 2 of terminal strip BB (NS) to lug 2 of terminal strip CC (NS).
- () Connect a 2-1/2" wire from lug 2 (NS) to lug 4 (NS) of terminal strip CC.
- () Connect a 3-3/4" wire from lug 4 of terminal strip CC (NS) to lug 1 of terminal strip DD (NS).
- () Connect a 5-3/4" wire from lug 1 of terminal strip DD (NS) to lug 1 of terminal strip EE (NS). Position this wire as shown in Pictorial 2.
- () Connect a 6-1/2" wire from lug 3 of phone jack E (NS) to lug 1 of terminal strip EE (NS).
- () Strip 3/4" insulation from one end of a 3" wire. Insert this end through lug 2 (NS) to lug 3 (NS) of phone jack E. Now solder lug 2 (S-2).
- () Connect the other end of this wire to lug 2 of triple phono socket D (S-1).
- () At one end of a 4" twisted pair, connect either wire to lug 1 of terminal strip CC (NS) and the other wire to lug 2 of terminal strip CC (NS). Insert the other end of this twisted pair through grommet M to be connected later.
- () Connect a 3" wire to lug 4 of terminal strip CC (NS). Insert the other end of this wire through hole Q to be connected later.
- () Connect a 4" wire to lug 3 of terminal strip EE (NS). Insert the other end of this wire through hole R to be connected later.

- () R1. Cut both leads of a 1 megohm (brown-black-green) 1/2 watt resistor to 5/8". Connect this resistor from lug 1 (NS) to lug 3 (NS) of phone jack E. Position as shown in Pictorial 2.
- () R2. Cut both leads of a 47 KΩ (yellow-violet-orange) 1/2 watt resistor to 1/2". Connect this resistor from lug 4 (NS) to lug 5 (NS) of triple phono socket D. Position as shown in Pictorial 2.

CAUTION: When preparing and installing shielded cable, avoid overheating the leads as excessive heat will melt the insulation and may cause a short circuit between the inner lead and the shield. A method of preparing shielded cable is shown in Detail 2B.

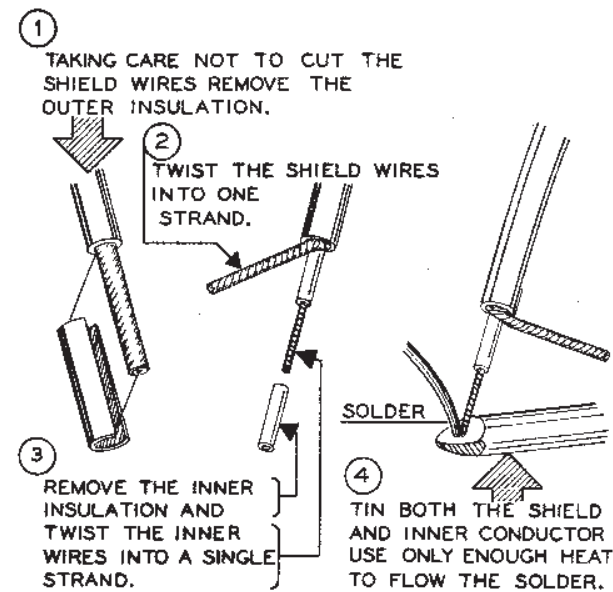

Detail 2B

- () Prepare an 8-1/2" length of shielded cable as shown in Detail 2C.

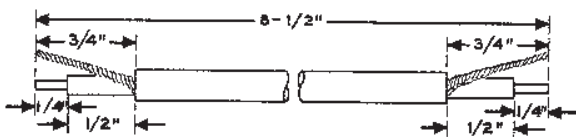

Detail 2C

- () At one end of this shielded cable, connect the shield lead to lug 3 (S-4) and the inner lead to lug 1 (S-2) of phone jack E. See Pictorial 2. Position this shielded cable as shown and insert the end through hole R to be connected later.

- () Prepare a 7" length of shielded cable as shown in Detail 2D. Use sleeving as shown.

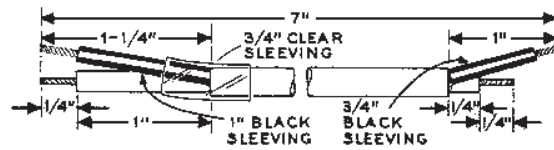

Detail 2D

- () At the end with the longer shield lead, connect the shield lead to lug 1 of terminal strip EE (NS). Connect the inner lead to lug 5 of tube socket V1 (S-1).
- () At the other end, connect the shield lead to lug 5 (S-2) and the inner lead to lug 4 (S-2) of triple phono socket D.
- () Prepare a 9-1/4" length of shielded cable as shown in Detail 2E.

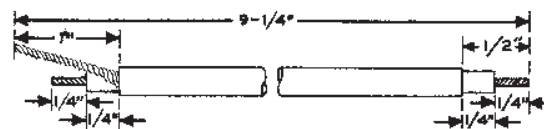

Detail 2E

- () At the end with the shield lead removed, connect the inner conductor to lug 3 of triple phono socket D (S-1). Position as shown in Pictorial 2 and insert the other end through hole R to be connected later.
- () Prepare another 9-1/4" lead as shown in Detail 2E. At the end with the shield lead removed, connect the inner conductor to lug 1 of the triple phono socket D (S-1). Position as shown and insert the other end through hole R to be connected later.

- () Prepare a 7-1/4" length of shielded cable as shown in Detail 2F. Use clear sleeving as shown.

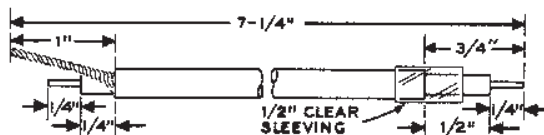

Detail 2F

- () Insert the end, with the shield lead, through hole N from the top of the chassis. Connect the inner lead to lug 8 of tube socket V2 (S-1). Connect the shield lead to lug 2 of terminal strip CC (NS). Do not let the shield touch the chassis. The free end of this cable will be connected later.

COMPONENT INSTALLATION

Refer to Pictorial 3 for the following steps.

- () R40. Connect an 8200 Ω (gray-red-red-gold) 5% 1/2 watt resistor from lug 1 (NS) to lug 2 (NS) of terminal strip HH.
- () C25. Connect a 20 μ fd electrolytic capacitor from ground lug 11 of tube socket V4 (NS) to lug 2 of terminal strip HH (NS). The positive (+) lead goes to V4.
- () Connect the selenium diode from lug 2 (S-3) to lug 3 (S-2) of terminal strip HH. Make sure that the positive (+) lead goes to lug 3.
- () R41. Connect a 3300 Ω (orange-orange-red-gold) 5% 1/2 watt resistor from ground lug 11 of tube socket V4 (S-2) to lug 1 of terminal strip HH (NS).
- () R34. Connect a 1000 Ω (brown-black-red) 1/2 watt resistor from lug 6 (S-1) to lug 1 (NS) of tube socket V4.
- () R31. Connect a 470 K Ω (yellow-violet-yellow) 1/2 watt resistor from lug 1 of tube socket V4 (NS) to lug 1 of terminal strip HH (NS).

NOTE: When installing the tubular capacitors, be sure that the end marked with a band or shoulder is placed as shown in Pictorial 3.

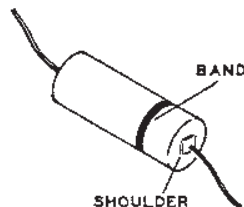

- () C17. Connect a .047 μ fd tubular capacitor from lug 1 of terminal strip GG (S-2) to lug 1 of tube socket V5 (NS).
- () C16. Connect a .047 μ fd tubular capacitor from lug 2 of terminal strip GG (S-2) to lug 1 of tube socket V4 (S-3). Use sleeving on both leads.
- () R32. Connect a 470 K Ω (yellow-violet-yellow) 1/2 watt resistor from lug 1 of terminal strip HH (S-4) to lug 1 of tube socket V5 (NS). Use sleeving on both leads.
- () R33. Connect a 1000 Ω (brown-black-red) 1/2 watt resistor from lug 6 (S-1) to lug 1 (S-3) of tube socket V5.
- () R36. Connect a 3000 Ω 5 watt resistor from lug 1 (S-3) to lug 2 (NS) of filter capacitor F. Use sleeving on both leads and position as shown in Pictorial 3.
- () R37. Connect a 1000 Ω (brown-black-red) 1 watt resistor from lug 2 of filter capacitor F (S-3) to lug 4 of filter capacitor G (NS).
- () R38. Connect a 15 K Ω (brown-green-orange) 1 watt resistor from lug 4 (S-3) to lug 1 (NS) of filter capacitor G.
- () R39. Connect a 22 K Ω (red-red-orange) 1 watt resistor from lug 1 (S-3) to lug 2 (S-2) of filter capacitor G. Position as shown. Do not use one of the 22 K Ω matched resistors.
- () R43. Connect an 18 K Ω (brown-gray-orange) 1/2 watt resistor from lug 2 of control H (NS) to lug 2 of terminal strip AA (NS). Use sleeving on the lead to terminal strip AA.
- () R44. Connect a 330 K Ω (orange-orange-yellow) 1/2 watt resistor from lug 2 of control H (S-3) to lug 1 of terminal strip AA (NS).
- () R30. Connect one of the 22 K Ω (red-red-orange) 1 watt matched resistors from lug 1 of terminal strip AA (NS) to lug 1 of tube socket V3 (S-2).
- () R27. Connect a 100 K Ω (brown-black-yellow) 1 watt resistor from lug 1 of terminal strip AA (S-4) to lug 2 of tube socket V3 (NS). Position as shown in Pictorial 3.
- () R29. Connect the remaining 22 K Ω (red-red-orange) 1 watt matched resistor from lug 2 of terminal strip AA (S-4) to lug 3 of tube socket V3 (S-2).
- () R35. Connect a 2200 Ω (red-red-red) 1/2 watt resistor from lug 8 of tube socket V3 (NS) to lug 1 of terminal strip BB (NS).
- () C18. Connect a 68 μ mf mica capacitor from lug 8 of tube socket V3 (NS) to lug 1 of terminal strip BB (S-3).
- () R26. Connect a 1000 Ω (brown-black-red) 1/2 watt resistor from lug 8 of tube socket V3 (S-3) to lug 2 of terminal strip BB (NS).

- () R25. Connect a 1 megohm (brown-black-green) 1/2 watt resistor from lug 7 of tube socket V3 (NS) to lug 2 of terminal strip BB (NS).
- () C14. Connect a .047 μ fd tubular capacitor from lug 7 of tube socket V2 (NS) to lug 7 of tube socket V3 (S-2). Use sleeving on both leads.
- () C8. Connect a .047 μ fd tubular capacitor from lug 6 of tube socket V2 (NS) to lug 4 of terminal strip BB (NS). Use sleeving on the lead going to tube socket V2.
- () C15. Insert one lead of a 680 μ fd mica capacitor through lug 6 (NS) to lug 2 (S-2) of tube socket V3. Now solder lug 6 (S-2). Connect the other lead of this capacitor to lug 3 of terminal strip BB (NS).
- () R28. Connect a 680 Ω (blue-gray-brown) 1/2 watt resistor from lug 2 (NS) to lug 3 (S-2) of terminal strip BB.
- () R23. Connect a 2200 Ω (red-red-red) 1/2 watt resistor from lug 9 of tube socket V2 (NS) to lug 2 of terminal strip CC (NS).
- () C13. Connect a .005 disc ceramic capacitor from lug 9 of tube socket V2 (S-2) to lug 2 of terminal strip CC (S-6).
- () R45. Connect a 100 K Ω (brown-black-yellow) 1/2 watt resistor from lug 1 (S-2) to lug 3 (NS) of terminal strip CC. Position as shown.
- () R24. Connect a 100 K Ω (brown-black-yellow) 1/2 watt resistor from lug 7 of tube socket V2 (S-2) to lug 3 of terminal strip CC (NS).
- () R17. Connect a 47 K Ω (yellow-violet-orange) 1/2 watt resistor from lug 6 of tube socket V2 (S-2) to lug 3 of terminal strip CC (S-4).
- () C7. Cut the lead at the marked end of a .047 μ fd tubular capacitor to 1-1/2". Slip a 1-1/4" length of sleeving over this lead and insert it into hole P to be connected later. Connect the other lead of this capacitor to lug 5 of tube socket V2 (NS).
- () R15. Connect a 1 megohm (brown-black-green) 1/2 watt resistor from lug 5 of tube socket V2 (S-2) to lug 4 of terminal strip CC (NS).
- () R16. Connect a 1000 Ω (brown-black-red) 1/2 watt resistor from lug 4 of tube socket V2 (S-1) to lug 4 of terminal strip CC (S-5). Position this resistor as shown in Pictorial 3.
- () C5. Cut both leads of a .1 μ fd tubular capacitor to 1-3/4". Insert a 1-1/2" length of sleeving over each lead.
- () Connect the lead at the unmarked end to lug 8 of tube socket V1 (NS). Insert the other lead through hole R to be connected later.
- () C6. Cut the lead at the unmarked end of a .047 μ fd tubular capacitor to 1-1/4". Slip a 1" length of sleeving over this lead and insert it into hole Q to be connected later. Connect the other lead of this capacitor to lug 7 of tube socket V1 (NS). Use sleeving.
- () R12. Connect a 2200 Ω (red-red-red) 1/2 watt resistor from lug 9 of tube socket V1 (S-1) to lug 1 of terminal strip DD (NS).
- () R11. Connect a 1 megohm (brown-black-green) 1/2 watt resistor from lug 8 of tube socket V1 (S-2) to lug 1 of terminal strip DD (S-4).
- () R13. Connect a 100 K Ω (brown-black-yellow) 1/2 watt resistor from lug 7 of tube socket V1 (S-2) to lug 2 of terminal strip DD (NS).
- () R7. Connect a 100 K Ω (brown-black-yellow) low-noise resistor from lug 6 of tube socket V1 (NS) to lug 2 of terminal strip DD (S-3).
- () C3. Connect a .015 μ fd tubular capacitor from lug 1 (NS) to lug 4 (NS) of terminal strip EE. Position this capacitor as shown in Pictorial 3.

- () C4. Connect a .005 μ fd tubular capacitor from lug 1 (NS) to lug 3 (NS) of terminal strip EE. Position as shown.
- () R10. Connect a 22 K Ω (red-red-orange) 1/2 watt resistor from lug 3 (NS) to lug 4 (S-2) of terminal strip EE.
- () C2. Connect a .1 μ fd tubular capacitor from lug 6 of tube socket V1 (S-2) to lug 2 of terminal strip EE (NS). Use sleeving on the lead going to the tube socket.
- () R9. Connect a 220 K Ω (red-red-yellow) 1/2 watt resistor from lug 2 (S-2) to lug 3 (S-4) of terminal strip EE.
- () R8. Connect a 1000 Ω (brown-black-red) 1/2 watt resistor from lug 4 of tube socket V1 (S-1) to lug 1 of terminal strip EE (S-6). Position as shown.
- () Install the line cord and line cord strain relief in hole Z as shown in Detail 3A. There should be approximately 3-1/2" of line cord inside the chassis.

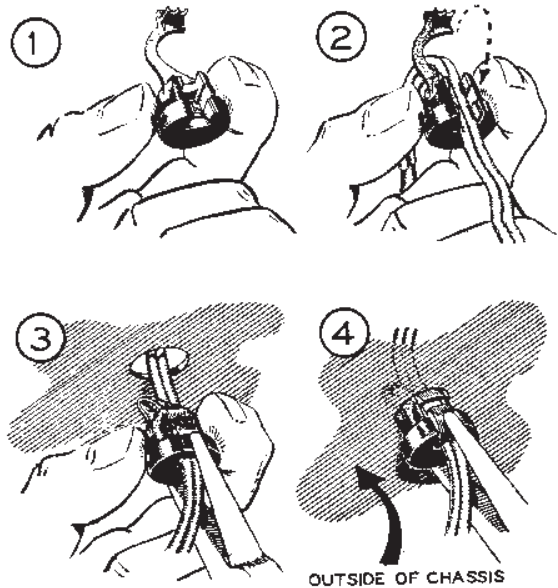

Detail 3A

- () Connect one of the line cord wires to lug 1 (S-2) and the other wire to lug 2 (S-2) of AC socket A.

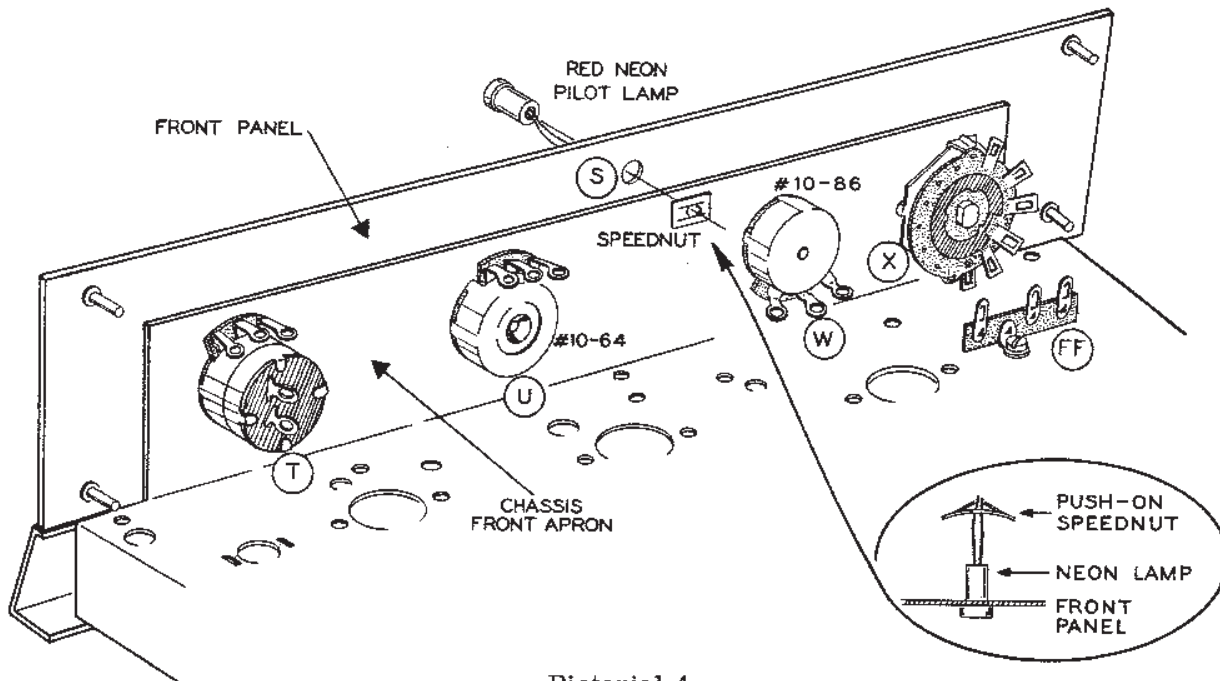

Pictorial 4

CONTROL MOUNTING AND FRONT PANEL WIRING

() Referring to Detail 4A, install the trim strip using #6 hardware as shown. Do not pinch any of the wires on the bottom of the chassis.

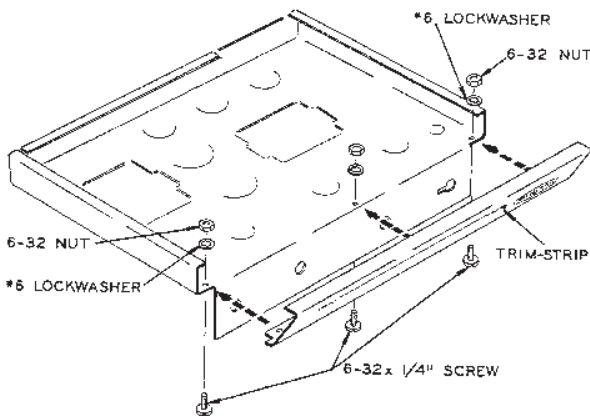

Detail 4A

Refer to Pictorial 4 for the following steps.

() R22. Position the front panel as shown in Pictorial 4 and mount a 1 megohm control with SPST switch (#19-37) at T. Use a control lockwasher, flat washer, and control nut as shown in Detail 4B. Do not tighten.

() Similarly mount a 1 megohm control (#10-64) at U. Do not tighten.

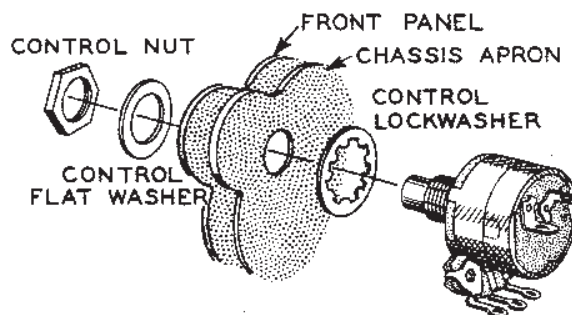

Detail 4B

() Mount a 1 megohm control (#10-86) at W. Position as shown in Pictorial 4. Do not tighten.

() Mount the SELECTOR switch (#63-270) at X. Use a flat washer and control nut. Fit the tab of the switch into the slot on the rear of the chassis front apron. Now tighten all four control nuts.

() Install the neon pilot lamp in hole S, using a push-on speednut as shown in Pictorial 4.

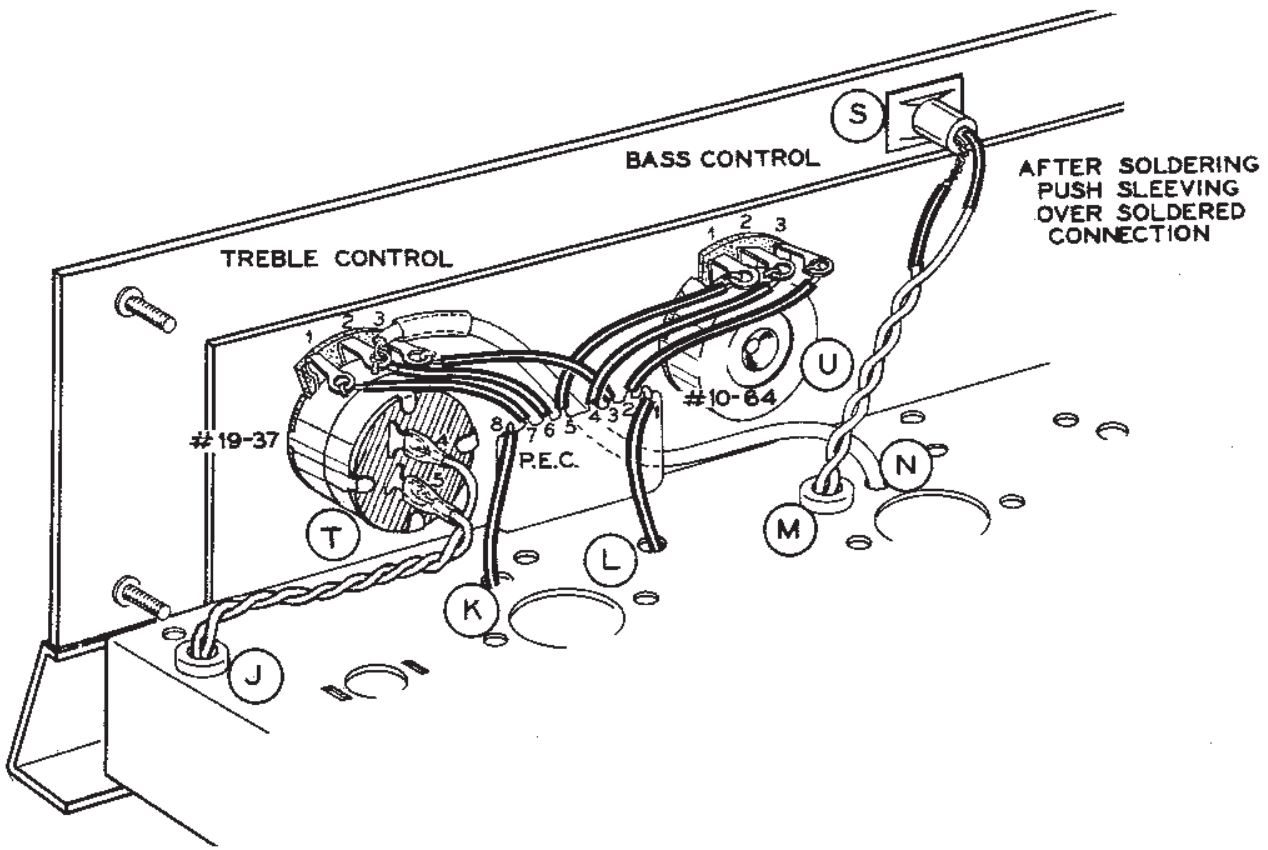

Pictorial 5

Refer to Pictorial 5 for the following steps.

() Locate the P.E.C. tone control network (#84-13) and cut its leads to the lengths indicated in Detail 5A. Use sleeving on

each lead of the P.E.C.

() Bend leads 1 and 8 of the P.E.C. down and insert these leads into holes K and L as shown in Pictorial 5.

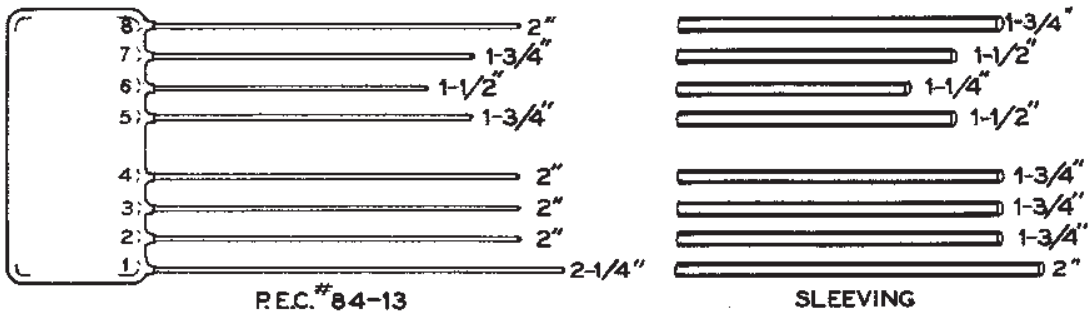

FULL SIZE

Detail 5A

- () Referring to Detail 5B, connect the P.E.C. lead coming from hole K to lug 2 of terminal strip BB (S-6). Connect the P.E.C. lead coming from hole L to lug 4 of terminal strip BB (S-2).

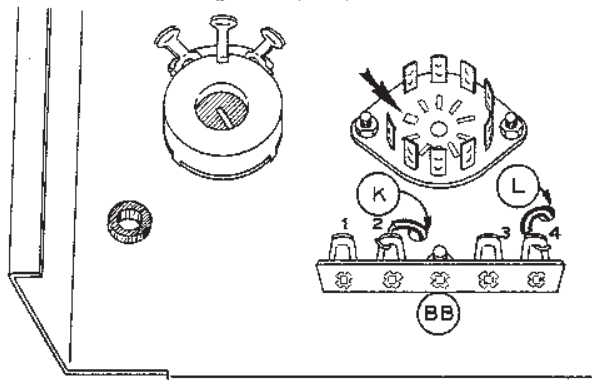

Detail 5B

Connect the remaining P.E.C. leads as follows:

<u>P.E.C. LEAD NUMBER</u>	<u>TO LUG</u>
() 7	1 of control T (S-1).
() 6	2 of control T (NS).
() 3	3 of control T (S-1).
() 5	1 of control U (S-1).
() 4	2 of control U (S-1).
() 2	3 of control U (S-1).

- () Connect the inner lead of the shielded cable coming up through hole N to lug 2 of control T (S-2). Make sure the clear plastic sleeving is in the position shown in Pictorial 5.
- () Slip a 3/4" length of the clear plastic sleeving over each wire of the twisted pair coming through grommet J.
- () Connect either lead of this twisted pair to lug 4 of control T (S-1).
- () Connect the other lead to lug 5 of control T (S-1).
- () Push the sleeving on both wires over the solder lugs and against control T.
- () Cut both leads of the neon pilot lamp to approximately 1/2" in length.
- () Slip a 1" length of sleeving over each wire of the twisted pair coming up through grommet M.
- () Connect either lead of this twisted pair to one of the leads of the neon pilot lamp (S-1). Now push the sleeving up over the soldered connection and against the pilot lamp.
- () Solder the other lead of the twisted pair to the remaining lead of the pilot lamp (S-1). Now push the sleeving up over this soldered connection and against the neon pilot lamp.

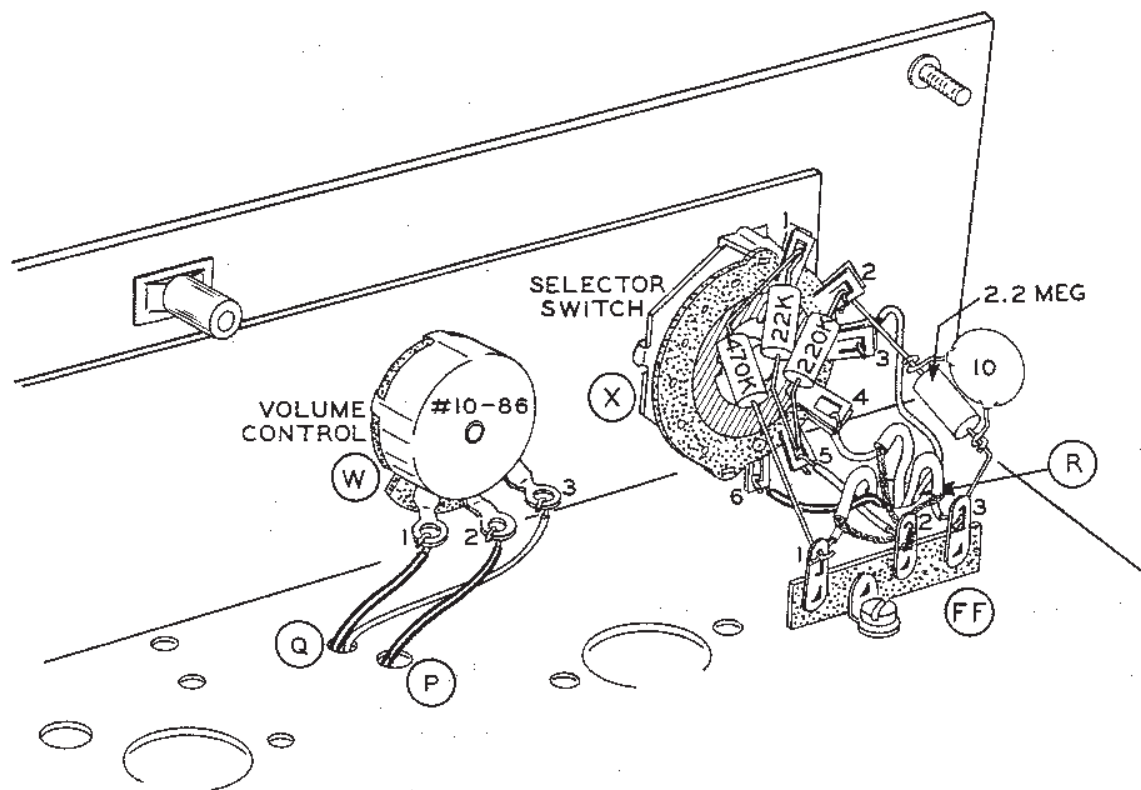

Pictorial 6

Refer to Pictorial 6 for the following steps.

- () Connect the lead with sleeving on it coming from hole Q to lug 1 of control W (S-1).
- () Connect the lead coming from hole P to lug 2 of control W (S-1).
- () Connect the wire coming from hole Q to lug 3 of control W (S-1).
- () Connect the wire coming from hole R to lug 3 of switch X (S-1). Solder both lugs. Position this wire as shown in Pictorial 6.
- () Connect a 2" wire from lug 5 of switch X (NS) to lug 2 of terminal strip FF (NS). Position this wire as shown.
- () Connect the lead with sleeving on it coming from hole R to lug 6 of switch X (S-1).
- () R6. Connect a 22 K Ω (red-red-orange) 1/2 watt resistor from lug 1 (NS) to lug 5 (NS) of switch X. Position as shown.
- () R4. Connect a 220 K Ω (red-red-yellow) 1/2 watt resistor from lug 2 (NS) to lug 5 (S-3) of selector switch X. Position as shown.
- () R5. Connect a 470 K Ω (yellow-violet yellow) 1/2 watt resistor from lug 1 of switch X (S-2) to lug 1 of terminal strip FF (NS). Solder both lugs on switch X.
- () Connect the inner lead of the shielded cable coming from lug 1 of the triple phono socket D, through hole R, to lug 1 of terminal strip FF (S-2). See Pictorial 2.
- () Connect the inner lead of the shielded cable coming from lug 3 of triple phono socket D, through hole R, to lug 3 of terminal strip FF (NS).

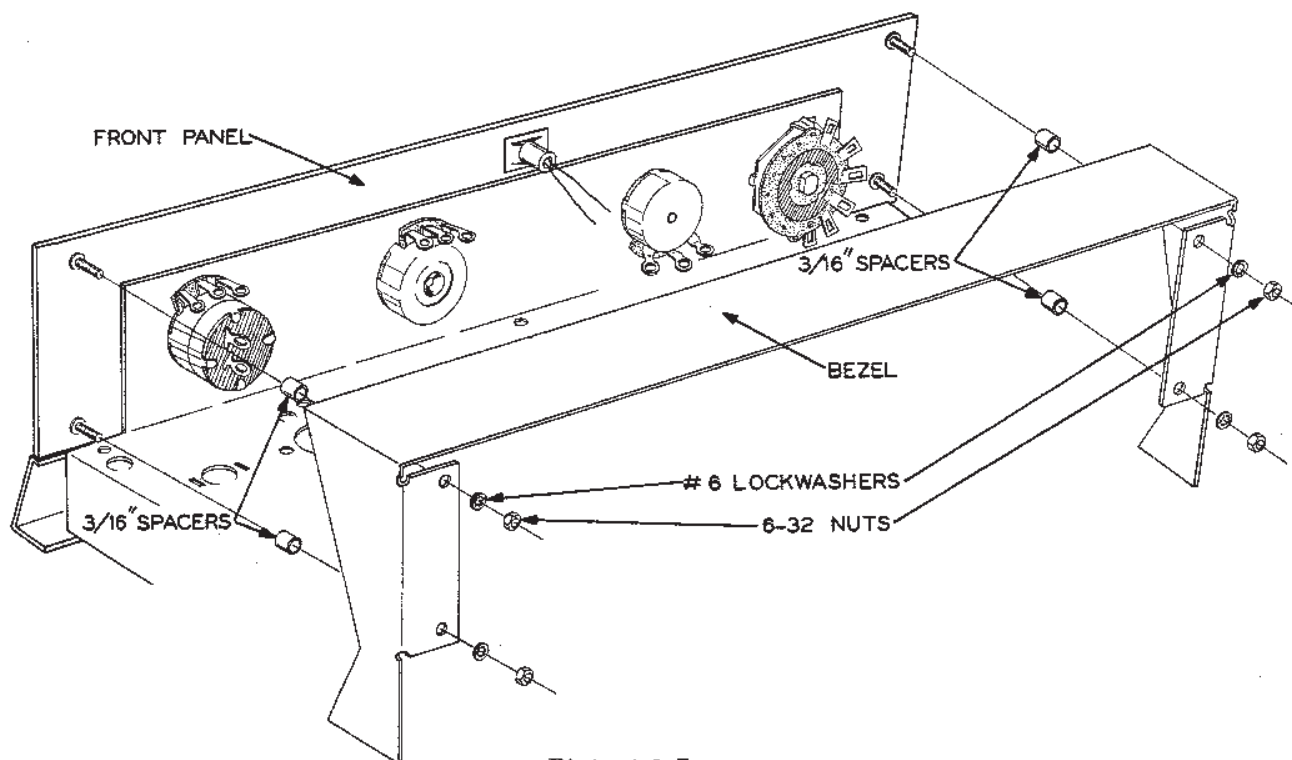

Pictorial 7

- () Connect the inner lead of the shielded cable coming from phone jack E, through hole R, to lug 4 of switch X (S-1). Be sure to solder both lugs.
- () Connect the shield leads from each of these three shielded cables to lug 2 of terminal strip FF (S-4).
- () R3 and C1. Referring to Detail 6A, prepare a resistor-capacitor combination, using a 2.2 megohm (red-red-green) 1/2 watt resistor and a 10 $\mu\mu\text{f}$ disc ceramic capacitor as shown. Connect this resistor-capacitor combination from lug 2 of switch X (S-2) to lug 3 of terminal strip FF (S-2). Solder both lugs on switch X.

Detail 6A

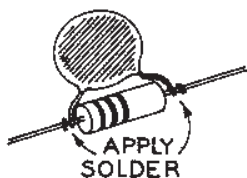

Refer to Pictorial 7 for the following steps.

- () Locate the bezel and place it over the chassis as shown in Pictorial 7. Place a 3/16"

spacer on each stud on the front panel. Place the bezel on the studs and then secure with #6 lockwashers and 6-32 nuts as shown.

- () Install the tubes in their respective tube sockets and install the tube shield over the tube at V1.
- () Cut the remaining shielded cable in half or to the desired length as determined by your installation, and attach a phono plug to each end of both resulting cables as shown in Detail 7A.

WIRING A PHONO PLUG

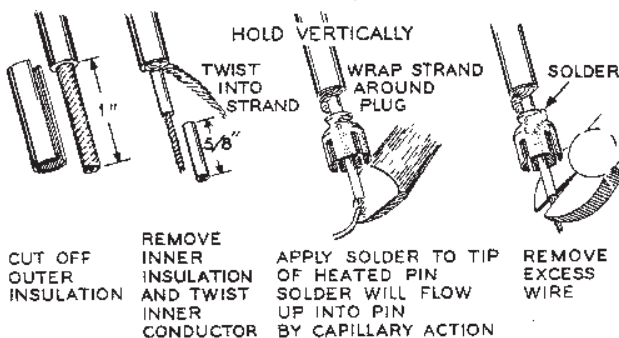

Detail 7A

TEST AND ADJUSTMENT

TEST

- () Make sure there are no short circuits in the wiring caused by wire clippings or stray pieces of solder.
- () If an ohmmeter is available, it would be well to check against the possibility of short circuits in the B+ and bias supplies before applying power for the first time. To make this check on the B+ supply, measure resistance between lug 1 of filter capacitor F and the chassis. With the ohmmeter set on one of the higher ranges, the meter pointer should kick down to a fairly low reading, indicating charging of the filter capacitors, and then rise slowly to a reading of at least 100,000 Ω . If a reading of less than 100,000 Ω is obtained, reverse the ohmmeter leads, after first discharging lug 1 of capacitor F to the chassis. If the reading is still less than 100,000 Ω , refer to the In Case Of Difficulty section of the manual.
- () To check the bias supply, measure the resistance between lug 2 of terminal strip HH and the chassis. After the capacitor charge, the reading should be at least 8,000 Ω . Ohmmeter polarity is not critical for this test. If the reading is less than 8,000 Ω , refer to the In Case Of Difficulty section.
- () Connect one of the speaker system leads to the terminal on the output terminal strip. Connect the other speaker lead to the terminal whose designation corresponds to the impedance of the speaker system.
- () Insert one of the 1-1/2 ampere slow-blow fuses in the fuse holder.
- () Install the four knobs on the front panel control shafts.
- () Set the controls as follows:

SELECTOR switch	PHONO
VOLUME	Fully counterclockwise
BASS	12 o'clock
TREBLE	OFF
- () Plug the line cord into an electrical outlet, 105 to 125 volts, 50/60 cycles AC only. Turn the Amplifier on by turning the TREBLE control clockwise until you feel the switch click. Leave this control set at 12 o'clock. After about 1/2 minute, the pilot lamp should glow red and the tube filaments should all be lit. The gray plates on the GZ34 and 7591 tubes should not glow red. If these plates start to turn red, it is a sign of excessive current drain, probably due to a short circuit. In this event, turn the power off immediately and do not re-apply power until the trouble is found and corrected. Refer to the In Case Of Difficulty section.

NOTE: A blue glow (fluorescence) around the plate structure of the 7591 tubes is normal and should not be interpreted as a sign of trouble.

CAUTION: Do not insert the screwdriver into the AC socket.

- () Each input except MIC, on the rear of the chassis may be checked by inserting a small screwdriver very carefully into each input socket and listening for a hum from the speaker. Use a low VOLUME control setting and make sure the SELECTOR switch is in the same position as the input that is being tested. To test the MIC input, insert a phone plug into the MIC input and touch the center terminal of the phono plug and listen for a hum from the speaker.

ADJUSTMENT

- () Before making any input connections, and with the unit turned on, wait approximately one minute for the tubes to warm up. Now advance the VOLUME control until a hum is heard in the speaker. Carefully adjust Hum balance control H until the hum level is minimum. As the hum is progressively reduced with the Hum balance control, it will probably be necessary to turn up the VOLUME control in order to better detect the condition of minimum hum, which is quite critical.

If the above tests were satisfactory, it can be assumed the Amplifier is operating properly.

FINAL ASSEMBLY

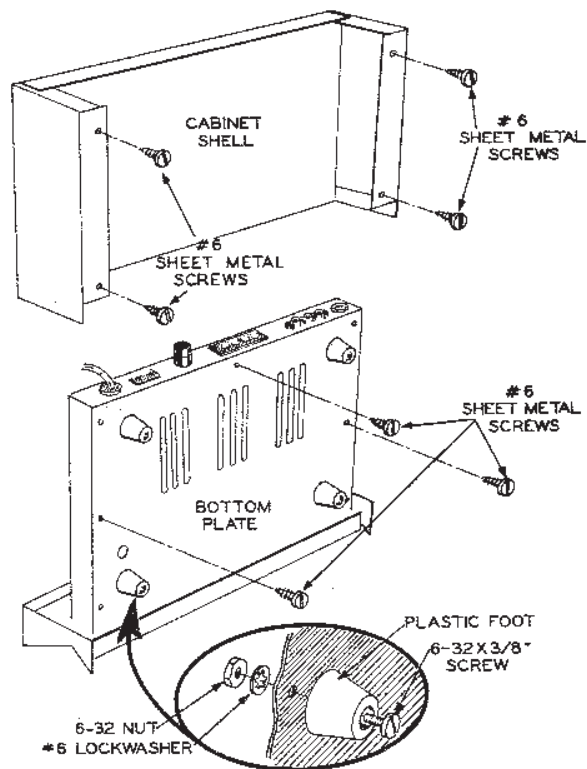

Pictorial 8

Refer to Pictorial 8 for the following steps.

- () Turn off the Amplifier and disconnect it from the AC power outlet. The pilot light will continue to glow for several seconds after the Amplifier is turned off.
- () Install the four plastic feet on the bottom plate as shown in Pictorial 8. Use 6-32 x 3/8" screws, #6 lockwashers, and 6-32 nuts.

- () Mount the bottom plate on the bottom of the chassis, using three #6 sheet metal screws. Install these screws in the holes shown.
- () Install the cabinet shell, using four #6 sheet metal screws as shown.
- () Readjust Hum balance control H with the cabinet and bottom plate installed.

INSTALLATION

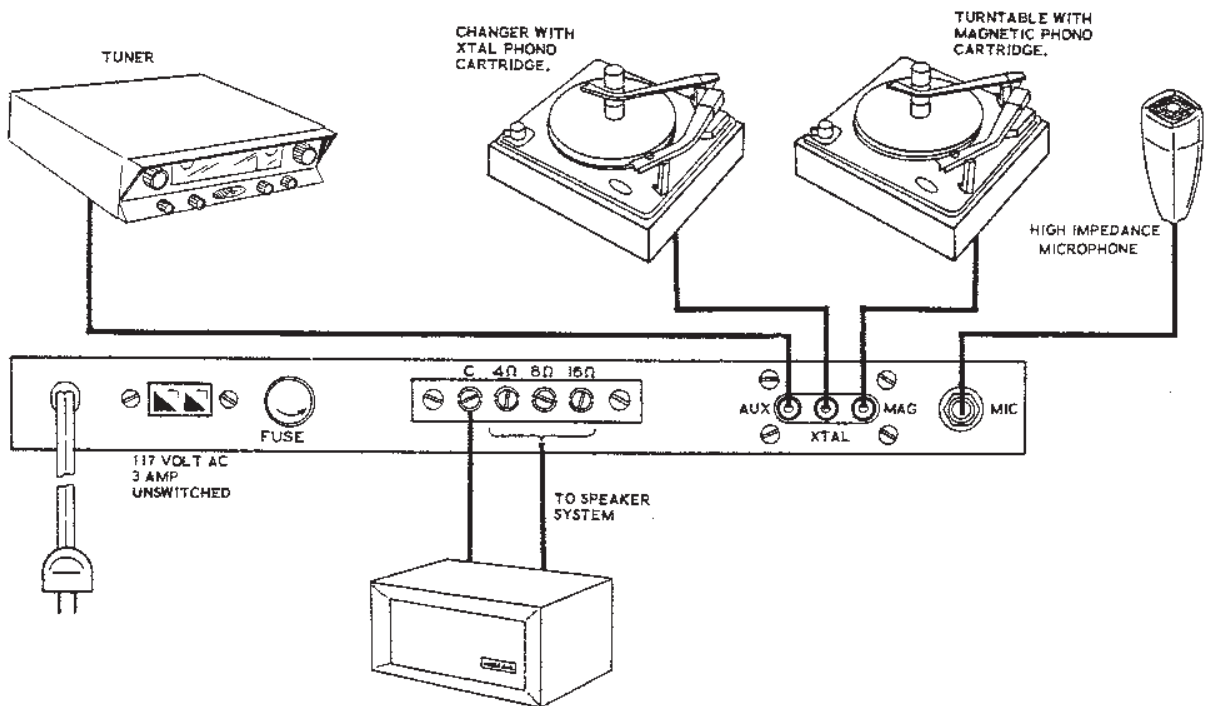

Pictorial 9

Because of its attractive styling, the Amplifier may be placed in the open or, if desired, it may be panel mounted, using the mounting dimensions listed in the Specifications section of the manual. Mounting in a horizontal panel, with the chassis vertical, is not recommended.

Since heat is normally generated in all power amplifiers, adequate ventilation around the cabinet is very important. At least one inch of open space behind the Amplifier and three inches of space above the cabinet is considered minimum for proper air circulation.

Pictorial 9 shows a typical high fidelity installation of the Amplifier. This installation is provided simply as an example and should be used only as a guide for installing your system. There are, of course, many other possible combinations of equipment that will provide equally good results.

INPUT CONNECTIONS

Shielded cables terminated in appropriate plugs should be used to make input signal connections to the Amplifier.

MIC - The MIC input is provided for use with most high-impedance microphones.

MAG PHONO - Low level magnetic and reluctance type phono pickup cartridges should be played through this input. RIAA equalization is provided.

XTAL PHONO - Crystal and ceramic type phono pickup cartridges should be played through this input. Compensation is provided for a proper frequency response when used with crystal and ceramic cartridges.

NOTE: The XTAL input can be modified for use as an additional AUX input by removing C1 and changing the values of R3 and R4 to correspond to the values of R5 and R6. Refer to the Schematic Diagram. The necessary resistors should be obtained locally.

AUX - The AUX input can be used with most transformer - operated, high - level signal sources, such as tuners, tape recorders, etc.

SPEAKER - Connections from the amplifier to the speaker system may be made with standard AC lamp cord or flat television antenna lead-in wire. Lamp cord is considered preferable for this application.

AC OUTLET - The AC outlet on the rear of the chassis is unswitched and may be used to provide power for accessory equipment used with the Amplifier.

OPERATION

Operation of the Amplifier is convenient and straightforward. Simply choose the desired input with the SELECTOR switch, and set the

VOLUME, BASS, and TREBLE controls for the desired listening level and tone.

IN CASE OF DIFFICULTY

1. Recheck the wiring. Trace each lead in colored pencil on the Pictorial as it is checked. It is frequently helpful to have a friend check your work. Someone who is not familiar with the unit may notice something consistently overlooked by the constructor.
2. It is interesting to note that about 90% of the kits that are returned for repair, do not function properly due to poor connections and soldering. Therefore, many troubles can be eliminated by reheating all connections to make sure that they are soldered as described in the Proper Soldering Techniques section of this manual.
3. Check to be sure that all tubes are in their proper locations. Make sure that all tubes light up properly.
4. Check the tubes with a tube tester or by substitution of tubes of the same types and known to be good.
5. Check the values of the component parts. Be sure that the proper part has been wired into the circuit, as shown in the pictorial diagrams and as called out in the wiring instructions.
6. Check for bits of solder, wire ends or other foreign matter which may be lodged in the wiring.
7. If, after careful checks, the trouble is still not located and a voltmeter is available, check voltage readings against those found on the Schematic Diagram. NOTE: All voltage readings were taken with an 11 megohm input vacuum tube voltmeter. Voltages may vary as much as 10% due to line voltage variations.
8. A review of the Circuit Description will prove helpful in indicating where to look for trouble.

HUM

An open electrolytic capacitor in the B+ supply, improper ground connections in the Amplifier, incorrect filament lead dress, or a heater-to-cathode short in one of the tubes could cause hum.

Ground loops in the audio cables can also cause hum. Usually the lowest overall hum will result if the shields of the audio cables are grounded at both ends. However, when there is more than one ground path between any two of the components of the high fidelity system, hum-causing ground loops are likely to result. If a ground loop is suspected, try disconnecting the shield of one or more of the audio cables, by pulling the phono plug out of the phono socket just far enough so the outer shell of the phono plug is disconnected but the center pin should still be making contact in the phono socket.

LOSS OF SIGNAL

A faulty tube, an open-circuited coupling capacitor or a short circuit from the signal path to ground could cause signal loss. Therefore, these points should be checked first.

A signal tracing procedure can also be used to locate a point of signal loss. First apply a suitable audio signal to the input; then, using either a signal tracer or an oscilloscope, check along the signal path to determine at which point the appropriate signal is missing. After obtaining this information, carefully check the associated wiring and parts.

If test instruments are not available for signal tracing, a .01 or a .05 μ fd capacitor can be used to find the stage that is not passing the applied signal. By holding one lead of the capacitor and touching the other lead to the control grid lug of each tube socket, a 60 cycle hum should be heard from the output. If, upon touching a grid lug, a hum is not heard, the associated circuitry should be suspected and thoroughly checked out.

CAUTION: Because there are high voltages at several points in the Amplifier circuitry, due care should be exercised to avoid personal shock when performing the checks described above.

SERVICE INFORMATION

SERVICE

If, after applying the information contained in this manual and your best efforts, you are still unable to obtain proper performance, it is suggested that you take advantage of the technical facilities which the Heath Company makes available to its customers.

The Technical Consultation Department is maintained for your benefit. This service is available to you at no charge. Its primary purpose is to provide assistance for those who encounter difficulty in the construction, operation or maintenance of HEATHKIT equipment. It is not intended, and is not equipped to function as a general source of technical information involving kit modifications nor anything other than the normal and specified performance of HEATHKIT equipment.

Although the Technical Consultants are familiar with all details of this kit, the effectiveness of their advice will depend entirely upon the amount and the accuracy of the information furnished by you. In a sense, **YOU MUST QUALIFY** for GOOD technical advice by helping the consultants to help you. Please use this outline:

1. Before writing, fully investigate each of the hints and suggestions listed in this manual under **In Case Of Difficulty**. Possibly it will not be necessary to write.
2. When writing, clearly describe the nature of the trouble and mention all associated equipment. Specifically report operating procedures, switch positions, connections to other units and anything else that might help to isolate the cause of trouble.

3. Report fully on the results obtained when testing the unit initially and when following the suggestions under In Case Of Difficulty. Be as specific as possible and include voltage readings if test equipment is available.
4. Identify the kit model number and date of purchase, if available. Also mention the date of the kit assembly manual. (Date at bottom of Page 1.)
5. Print or type your name and address, preferably in two places on the letter.

With the preceding information, the consultant will know exactly what kit you have, what you would like it to do for you and the difficulty you wish to correct. The date of purchase tells him whether or not engineering changes have been made since it was shipped to you. He will know what you have done in an effort to locate the cause of trouble and, thereby, avoid repetitious suggestions. In short, he will devote full time to the problem at hand, and through his familiarity with the kit, plus your accurate report, he will be able to give you a complete and helpful answer. If replacement parts are required, they will be shipped to you, subject to the terms of the Warranty.

The Factory Service facilities are also available to you, in case you are not familiar enough with electronics to provide our consultants with sufficient information on which to base a diagnosis of your difficulty, or in the event that you prefer to have the difficulty corrected in this manner. You may return the completed instrument to the Heath Company for inspection and necessary repairs and adjustments. You will be charged a minimal service fee, plus the price of any additional parts or material required. However, if the completed kit is returned within the Warranty period, parts charges will be governed by the terms of the Warranty. State the date of purchase, if possible.

Local Service by Authorized HEATHKIT Service Centers is also available in some areas and often will be your fastest, most efficient method of obtaining service for your HEATHKIT equipment. Although you may find charges for local

service somewhat higher than for factory service, the amount of increase is usually offset by the transportation charge you would pay if you elected to return your kit to the Heath Company.

HEATHKIT Service Centers will honor the regular 90 day HEATHKIT Parts Warranty on all kits, whether purchased through a dealer or directly from Heath Company; however, it will be necessary that you verify the purchase date of your kit.

Under the conditions specified in the Warranty, replacement parts are supplied without charge; however, if the Service Center assists you in locating a defective part (or parts) in your kit, or installs a replacement part for you, you may be charged for this service.

HEATHKIT equipment purchased locally and returned to Heath Company for service must be accompanied by your copy of the dated sales receipt from your authorized HEATHKIT dealer in order to be eligible for parts replacement under the terms of the Warranty.

THIS SERVICE POLICY APPLIES ONLY TO COMPLETED EQUIPMENT CONSTRUCTED IN ACCORDANCE WITH THE INSTRUCTIONS AS STATED IN THE MANUAL. Equipment that has been modified in design will not be accepted for repair. If there is evidence of acid core solder or paste fluxes, the equipment will be returned NOT repaired.

For information regarding modification of HEATHKIT equipment for special applications, it is suggested that you refer to any one or more of the many publications that are available on all phases of electronics. They can be obtained at or through your local library, as well as at most electronic equipment stores. Although the Heath Company sincerely welcomes all comments and suggestions, it would be impossible to design, test, evaluate and assume responsibility for proposed circuit changes for special purposes. Therefore, such modifications must be made at the discretion of the kit builder, using information available from sources other than the Heath Company.



REPLACEMENTS

Material supplied with HEATHKIT products has been carefully selected to meet design requirements and ordinarily will fulfill its function without difficulty. Occasionally improper instrument operation can be traced to a faulty component. Should inspection reveal the necessity for replacement, write to the Heath Company and supply all of the following information.

- A. Thoroughly identify the part in question by using the part number and description found in the manual Parts List.
- B. Identify the type and model number of kit in which it is used.
- C. Mention date of purchase.
- D. Describe the nature of defect or reason for requesting replacement.

The Heath Company will promptly supply the necessary replacement. PLEASE DO NOT RETURN THE ORIGINAL COMPONENT UNTIL SPECIFICALLY REQUESTED TO DO SO. Do not dismantle the component in question as this will void the guarantee. This replacement policy does not cover the free replacement of parts that may have been broken or damaged through carelessness on the part of the kit builder.

SHIPPING INSTRUCTIONS

In the event that your instrument must be returned for service, these instructions should be carefully followed.

ATTACH A TAG TO THE EQUIPMENT BEARING YOUR NAME, COMPLETE ADDRESS, DATE OF PURCHASE, AND A BRIEF DESCRIPTION OF THE DIFFICULTY ENCOUNTERED. Wrap the equipment in heavy paper, exercising care to prevent damage. Place the wrapped equipment in a stout carton of such size that at least three inches of shredded paper, excelsior, or other resilient packing material can be placed between all sides of the wrapped equipment and the carton. Close and seal the carton with gummed paper tape, or alternately, tie securely with stout cord. Clearly print the address on the carton as follows:

To: HEATH COMPANY
Benton Harbor, Michigan

Include your name and return address on the outside of the carton. Preferably affix one or more "Fragile" or "Handle With Care" labels to the carton, or otherwise so mark with a crayon of bright color. Ship by insured parcel post or prepaid express; note that a carrier cannot be held responsible for damage in transit if, in HIS OPINION, the article is inadequately packed for shipment.

WARRANTY

Heath Company warrants that for a period of three months from the date of shipment, all Heathkit parts shall be free of defects in materials and workmanship under normal use and service and that in fulfillment of any breach of such warranty, Heath Company shall replace such defective parts upon the return of the same to its factory. The foregoing warranty shall apply only to the original buyer, and is and shall be in lieu of all other warranties, whether express or implied and of all other obligations or liabilities on the part of Heath Company and in no event shall Heath Company be liable for any anticipated profits, consequential damages, loss of time or other losses incurred by the buyer in connection with the purchase, assembly or operation of Heathkits or components thereof. No replacement shall be made of parts damaged by the buyer in the course of handling or assembling Heathkit equipment.

NOTE: The foregoing warranty is completely void and we will not replace, repair or service instruments or parts thereof in which acid core solder or paste fluxes have been used.

HEATH COMPANY

TYPICAL COMPONENT TYPES

This chart is a guide to commonly used types of electronic components. The symbols and related illustrations

should prove helpful in identifying most parts and reading the schematic diagrams.

<p>RESISTOR</p>	<p>CAPACITOR</p>	<p>TUBE</p>
<p>POTENTIOMETER (CONTROL)</p>	<p>ELECTROLYTIC CAPACITOR</p>	<p>TRANSISTOR</p>
<p>TRANSFORMER (IRON CORE)</p>	<p>VARIABLE CAPACITOR</p>	<p>RECTIFIER (DIODE)</p>
<p>TRANSFORMER (ADJUSTABLE POWDERED IRON CORE) ARROW INDICATES DIRECTION OF CORE MOVEMENT TO INCREASE INDUCTANCE</p>	<p>BATTERY</p>	<p>NEON BULB</p>
<p>TRANSFORMER (ADJUSTABLE CORE)</p>	<p>PHONO JACK</p>	<p>ILLUMINATING BULB</p>
<p>POWER TRANSFORMER</p>	<p>PHONE JACK</p>	<p>METER</p>
<p>INDUCTOR (COIL)</p>	<p>RECEPTACLE</p>	<p>SPST SWITCH (TOGGLE) DPDT</p>
<p>PIEZOELECTRIC CRYSTAL</p>	<p>SPEAKER</p>	<p>SWITCH (ROTARY)</p>
<p>BINDING POST</p>	<p>MICROPHONE</p>	<p>FUSE</p>
<p>ANTENNA</p> <p>GENERAL LOOP</p>	<p>EARTH GROUND</p> <p>CHASSIS GROUND</p>	<p>CONDUCTORS</p> <p>NOT CONNECTED CONNECTED SHIELDED</p>

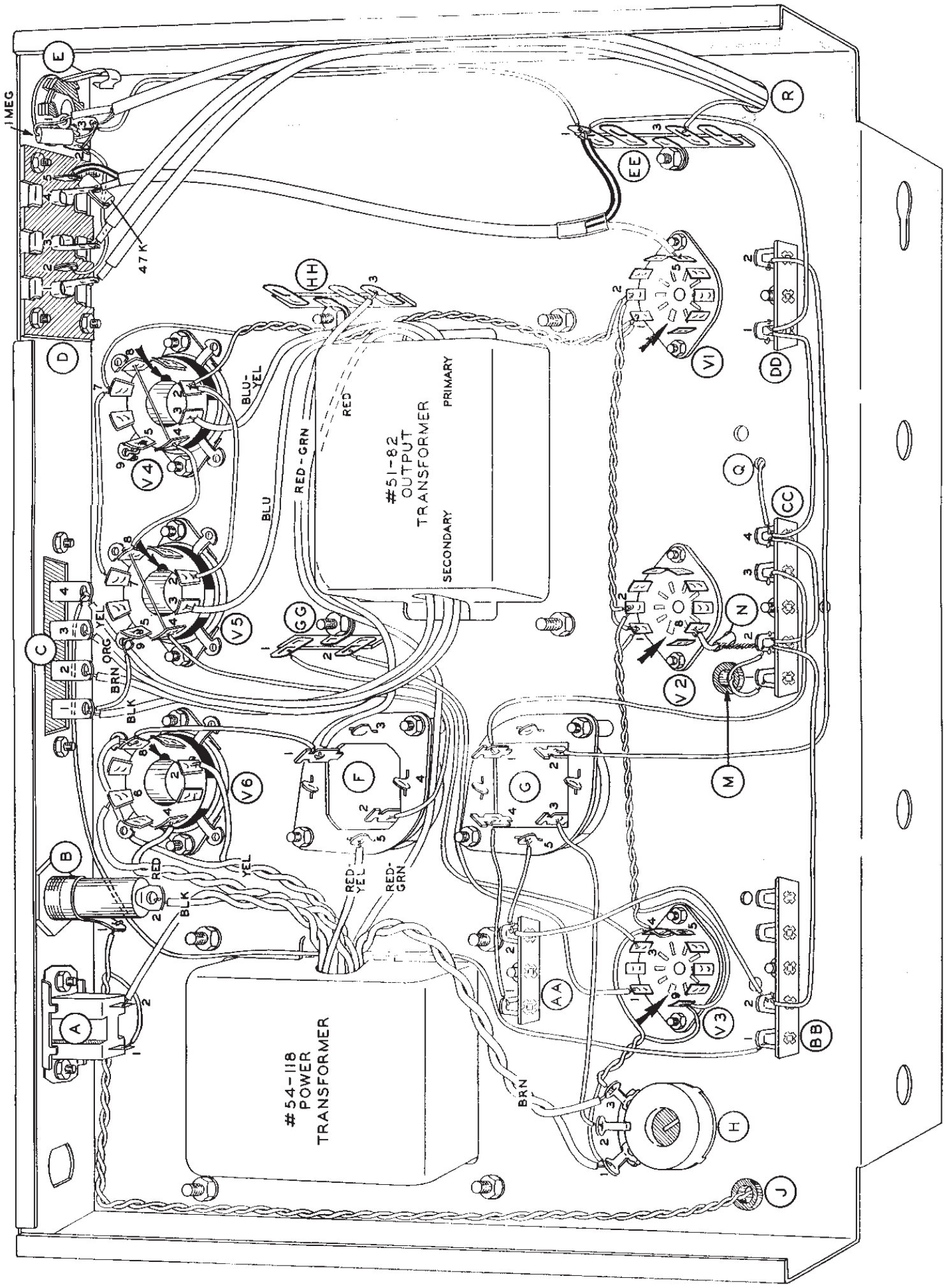

Pictorial 2

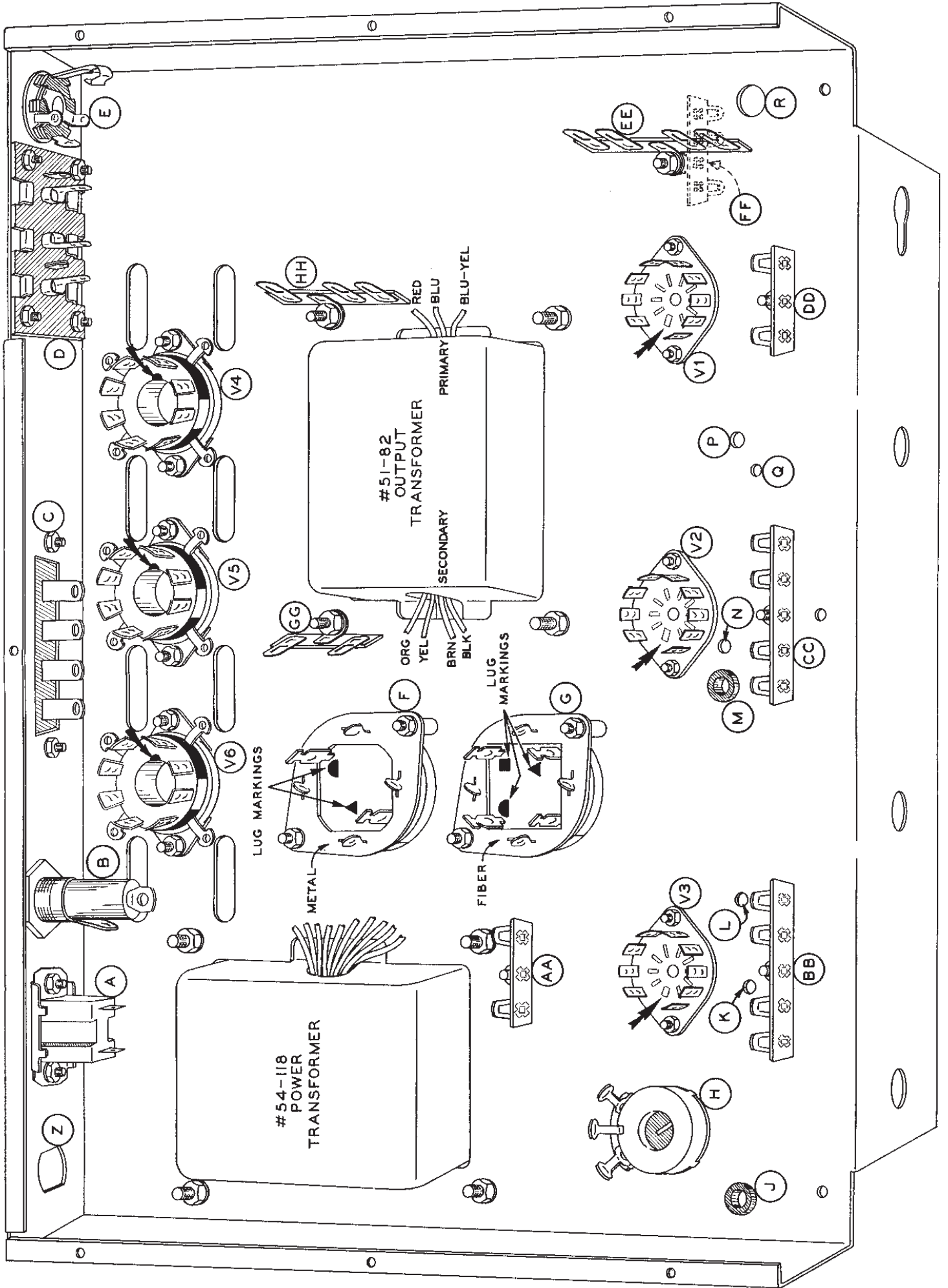

Pictorial 1

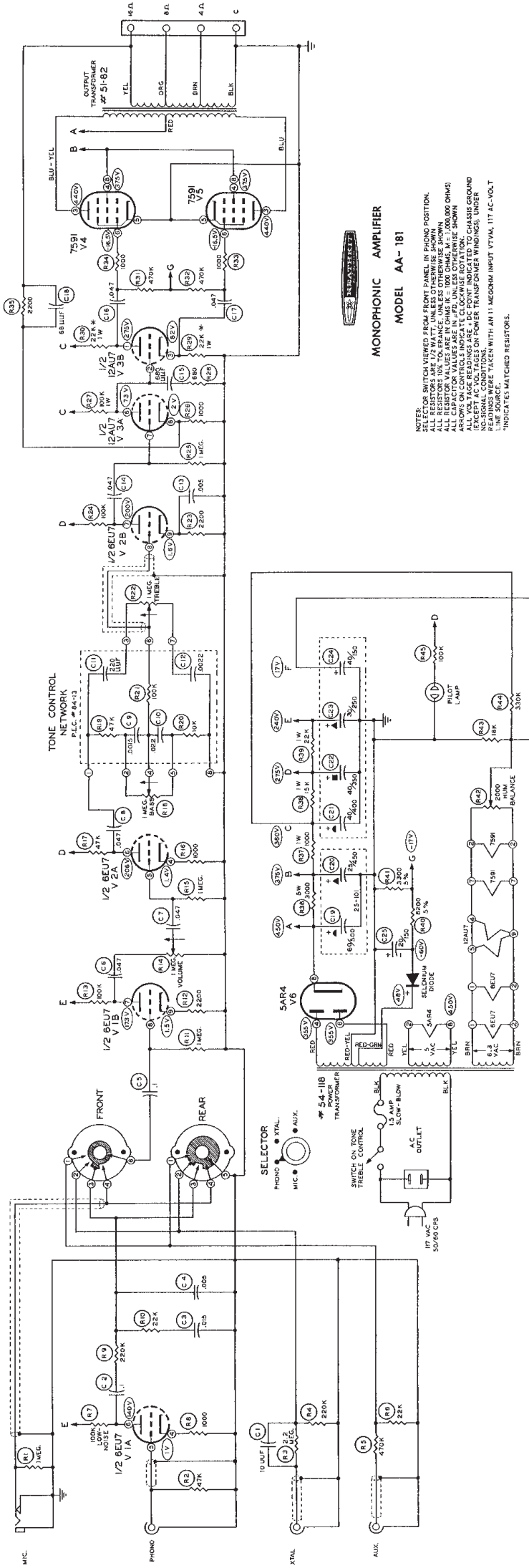

MONOPHONIC AMPLIFIER
MODEL AA-181

NOTES:
SELECTOR SWITCH WRENCH FROM FRONT PANEL IN PHONO POSITION.
ALL RESISTORS ARE 1/2 WATT, UNLESS OTHERWISE SHOWN.
ALL CAPACITORS ARE 50V UNLESS OTHERWISE SHOWN.
ALL RESISTOR VALUES ARE IN OHMS, UNLESS OTHERWISE SHOWN.
ALL CAPACITOR VALUES ARE IN µF, UNLESS OTHERWISE SHOWN.
ALL VOLTAGE READINGS ARE IN DC POINT INDICATED TO CHASSIS GROUND (EXCEPT AC VOLTAGES ON POWER TRANSFORMER WINDINGS), UNDER LOAD.
VOLTAGE READINGS WERE TAKEN WITH AN 11 MEGOHM INPUT VTVM, 117 AC-VOLT LINE SOURCE.
INDICATES MATCHED RESISTORS.

