







# SCHEMATIC OF THE HEATHKIT® VIDEO TERMINAL MODEL H19

**NOTES:**

1. COMPONENT NUMBERS ARE IN THE FOLLOWING GROUPS:
  - 1- 99 PARTS MOUNTED ON THE CHASSIS.
  - 101-199 PARTS MOUNTED ON THE POWER SUPPLY CIRCUIT BOARD.
  - 201-299 PARTS MOUNTED ON THE VIDEO CIRCUIT BOARD.
  - 301-399 PARTS MOUNTED ON THE KEYBOARD CIRCUIT BOARD.
  - 401-499 PARTS MOUNTED ON THE LOGIC CIRCUIT BOARD.
2. RESISTORS MOUNTED ON THE VIDEO CIRCUIT BOARD ARE 1/2-WATT, 5% UNLESS MARKED OTHERWISE. RESISTORS MOUNTED ON THE LOGIC CIRCUIT BOARD ARE 1/4-WATT, 5% UNLESS MARKED OTHERWISE. RESISTOR VALUES ARE IN OHMS (k=1,000; M=1,000,000).
3. ALL CAPACITORS ARE IN  $\mu$ F UNLESS MARKED OTHERWISE.
4.  THIS SYMBOL INDICATES CHASSIS GROUND.
5.  THIS SYMBOL INDICATES CIRCUIT BOARD GROUND.
6.  THIS SYMBOL INDICATES WHERE A WIRE CONNECTS TO A CIRCUIT BOARD.
7.  THIS SYMBOL INDICATES A MECHANICAL CONNECTOR.
8.  THIS SYMBOL INDICATES A PART THAT IS SHOWN ON A CIRCUIT BOARD, BUT IS ACTUALLY MOUNTED ON THE CHASSIS.
9.  THIS SYMBOL INDICATES AN INTERRUPTED LINE. LAY A STRAIGHT EDGE ON THE ARROW TO SEE WHERE IT GOES TO OR COMES FROM.
10.  THIS SYMBOL INDICATES A DC VOLTAGE TAKEN WITH A HIGH IMPEDANCE VOLTMETER FROM THE POINT INDICATED TO CHASSIS GROUND. VOLTAGES MAY VARY  $\pm 20\%$ .
11. FUSE F1 IS CRITICAL FOR CONTINUED SAFETY. REPLACE IT ONLY WITH A PART OF THE SAME RATING OR WITH THE PROPER HEATH PART.

Part of 595-2284-04

Page 1 of 2

Copyright © 1979  
Heath Company  
All Rights Reserved  
Printed in the United States of America

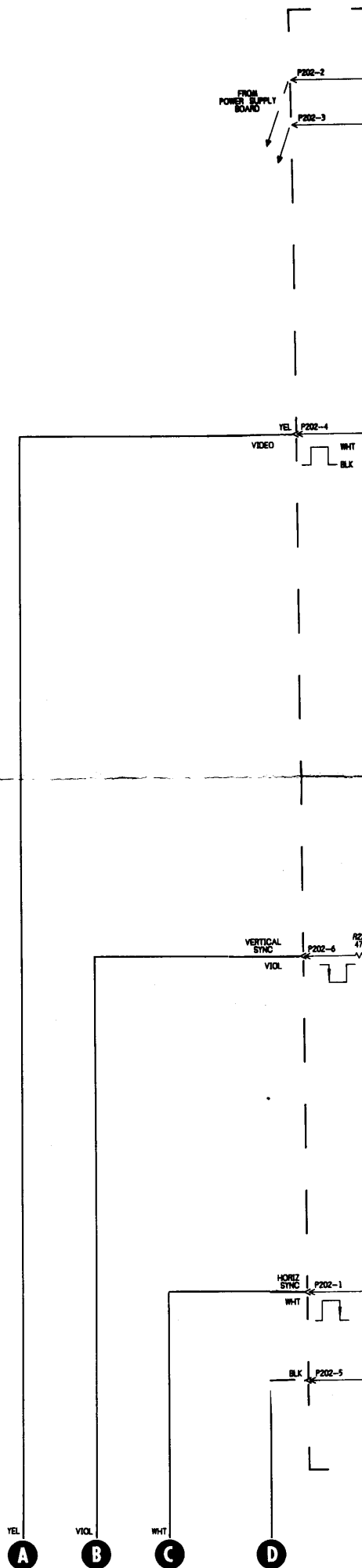

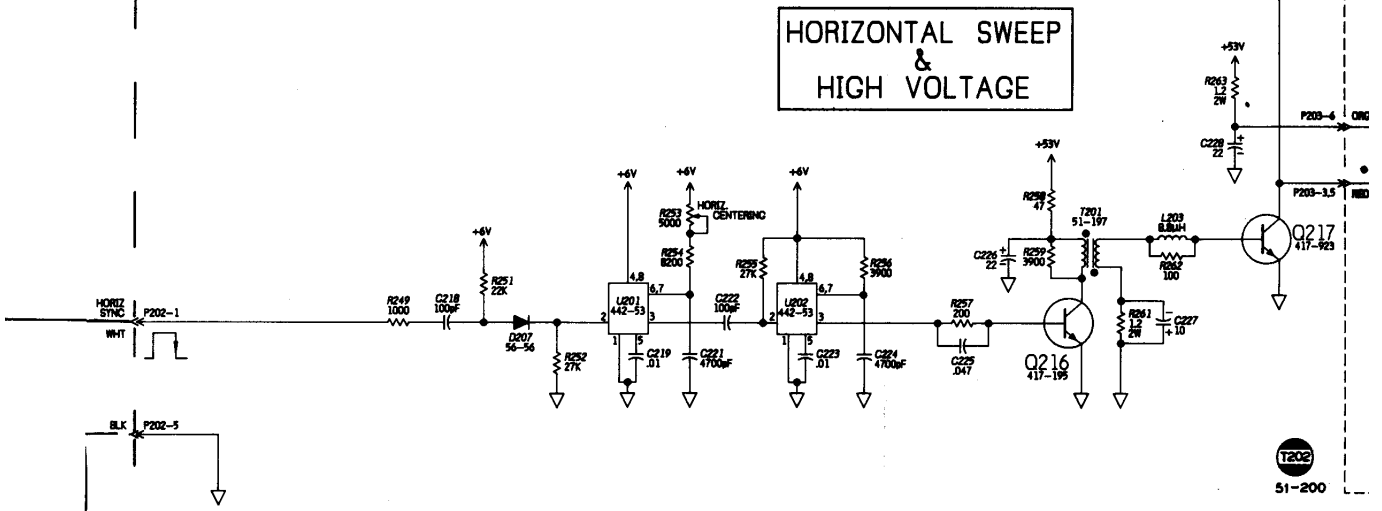
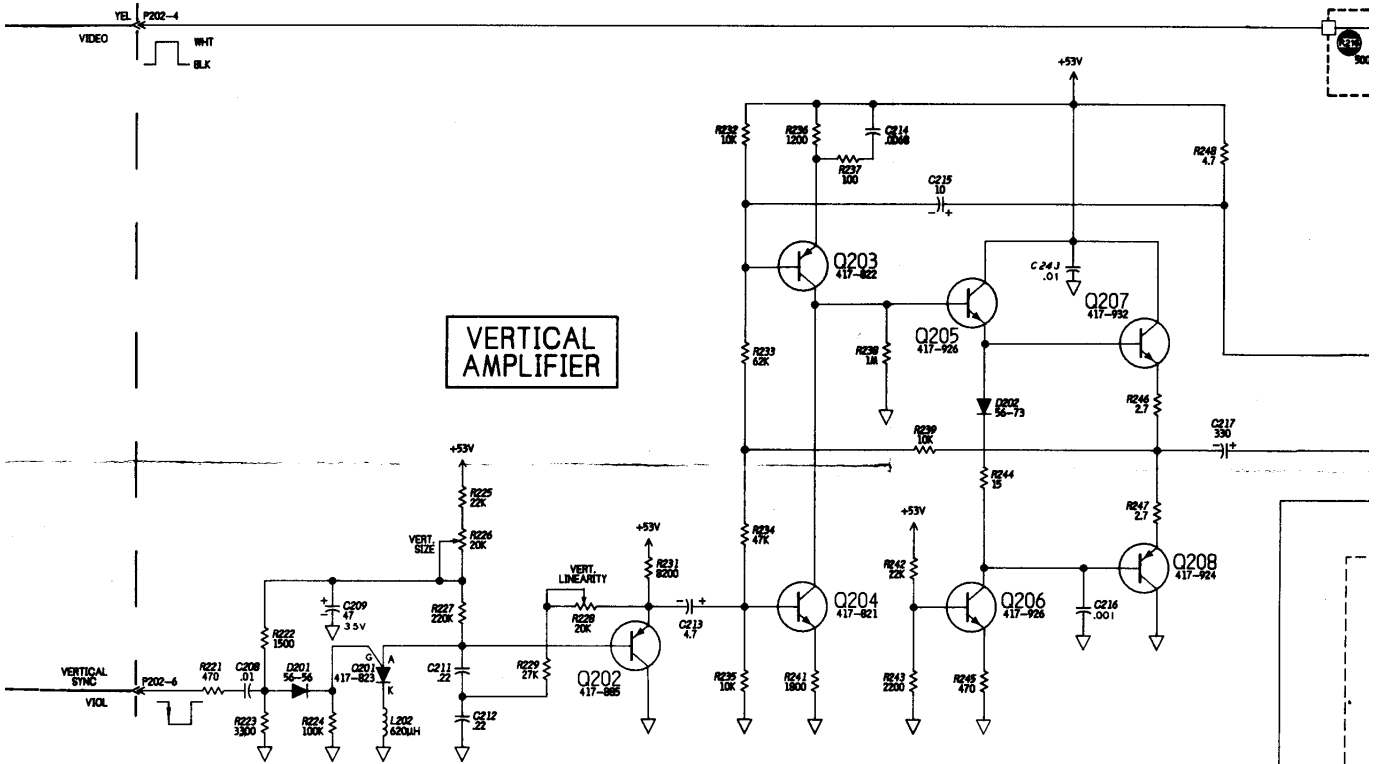
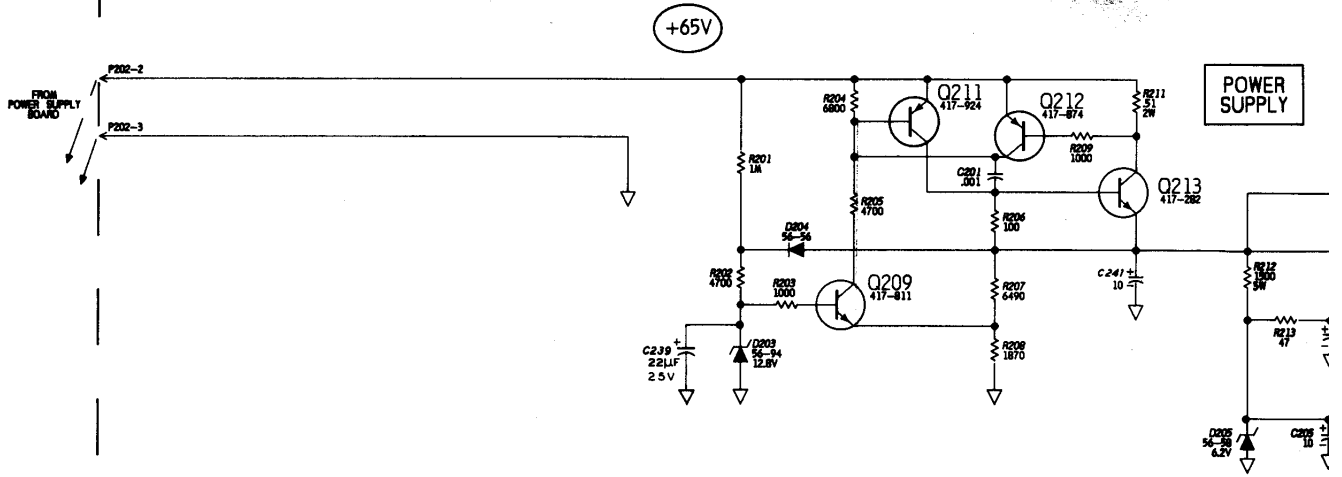

**D**

POWER SUPPLY

VIDEO CIRCUIT BOARD

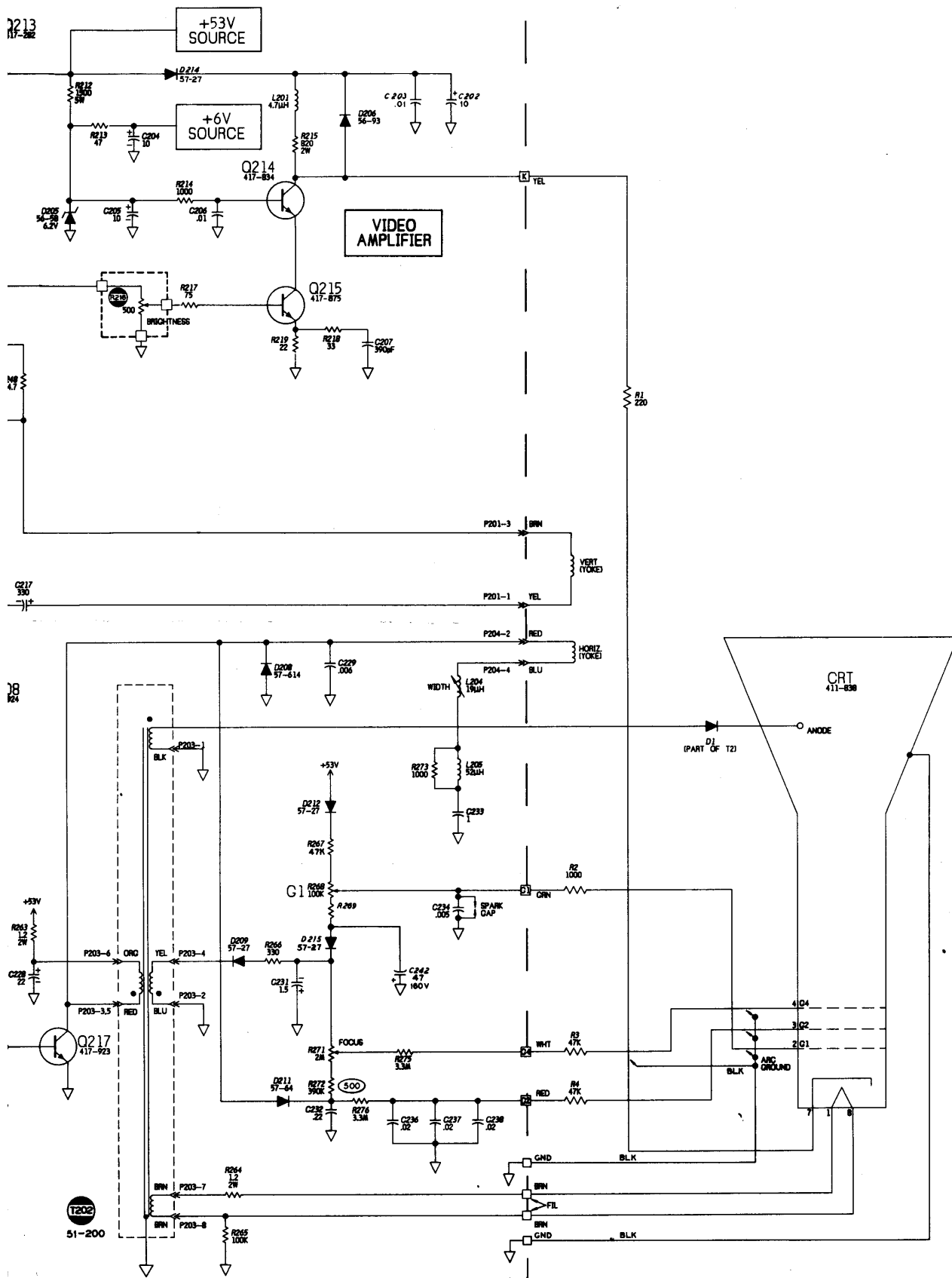

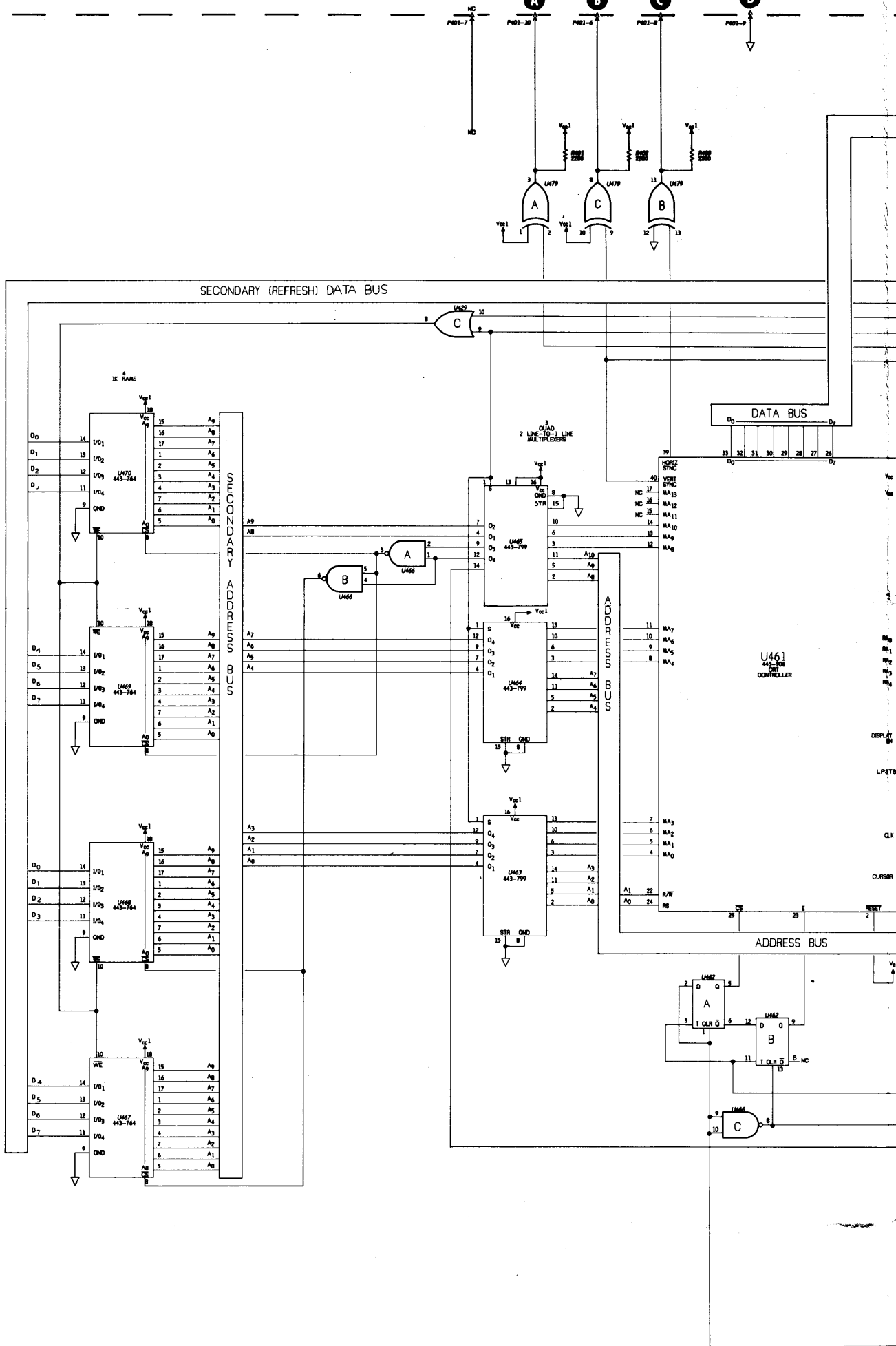

F1 .2A SLOW-BLOW  
421-20 FOR 240 VAC

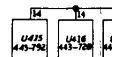
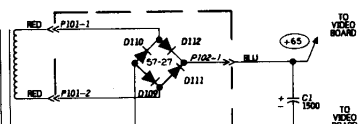

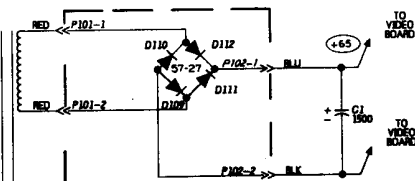
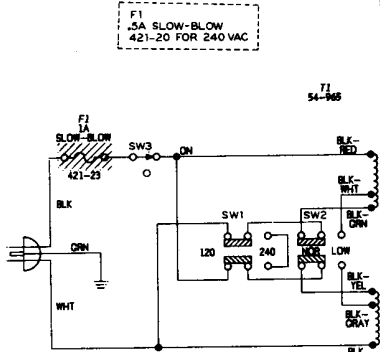
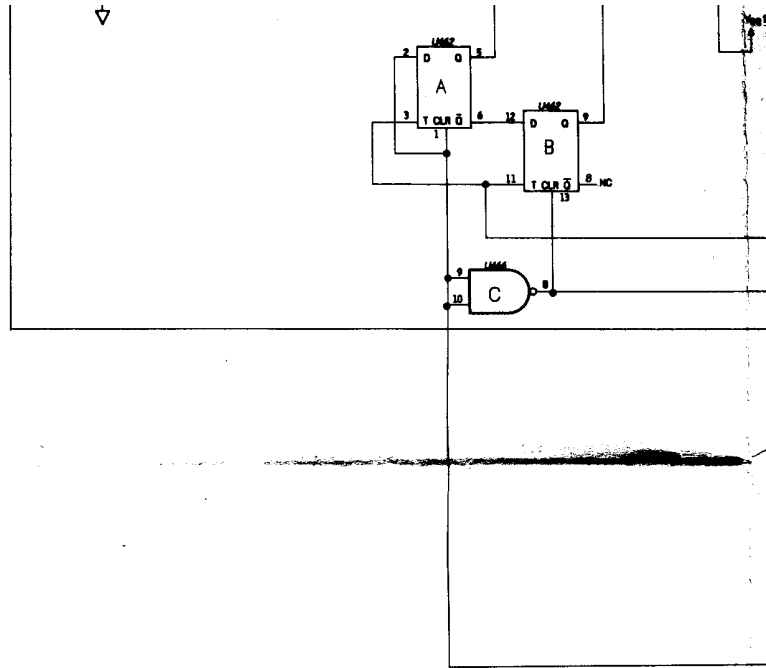
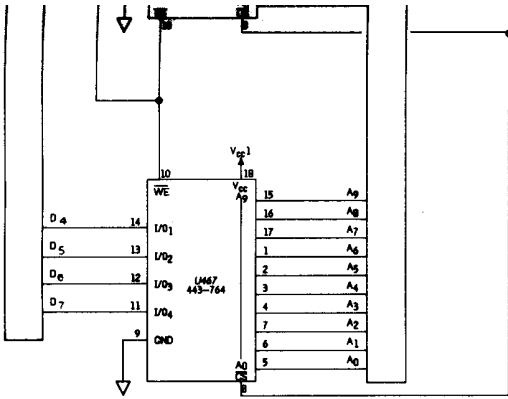

POWER SUPPLY  
CIRCUIT BOARD

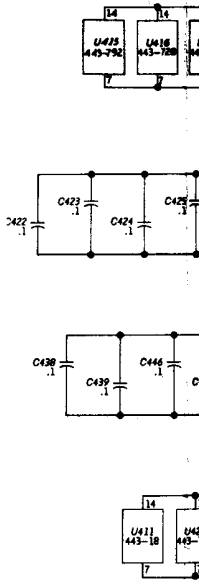
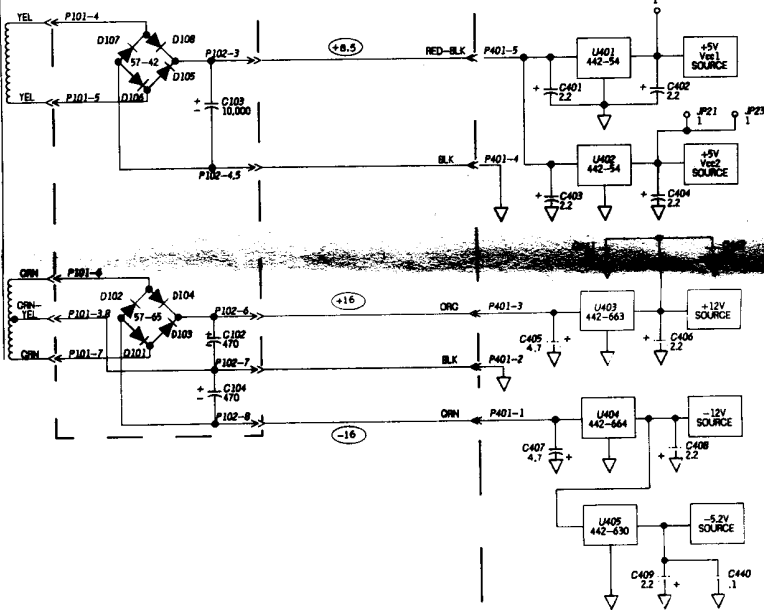

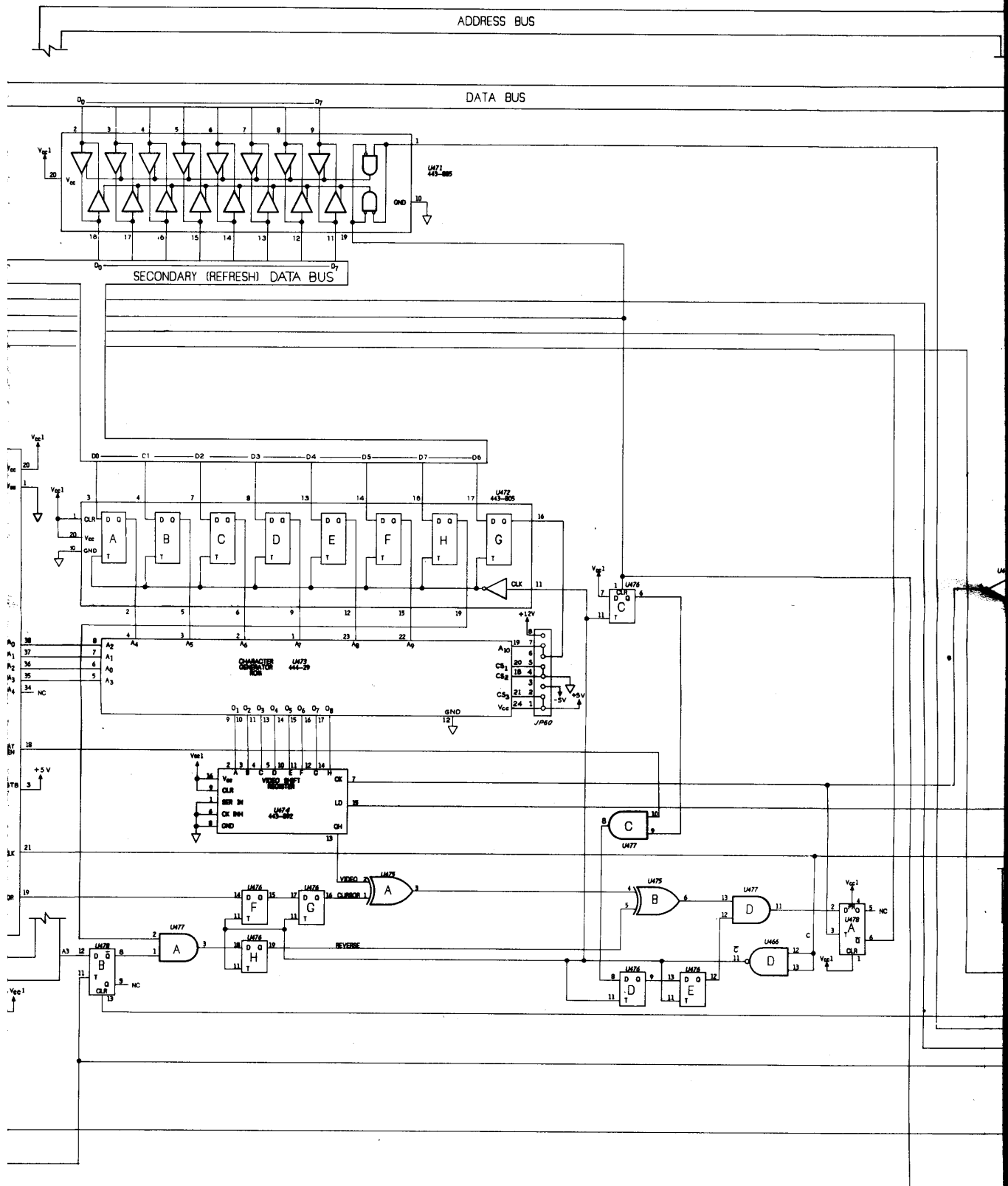

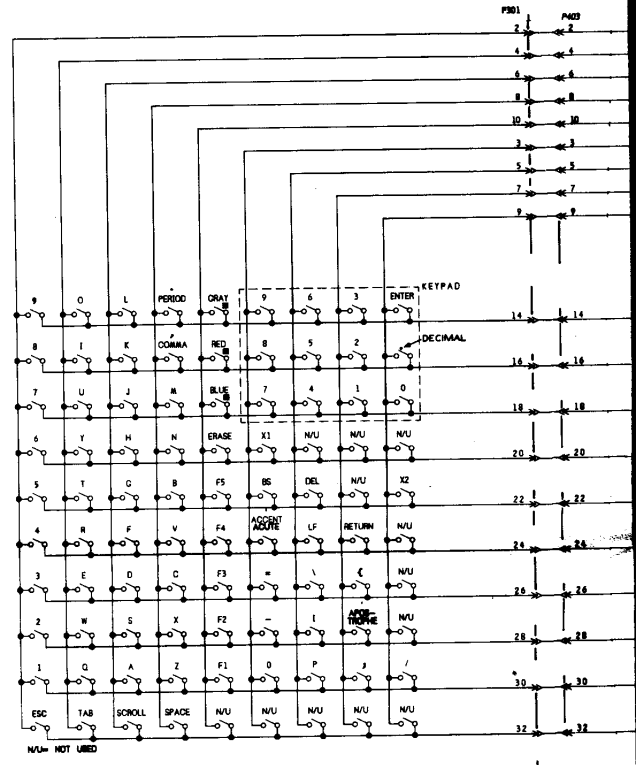
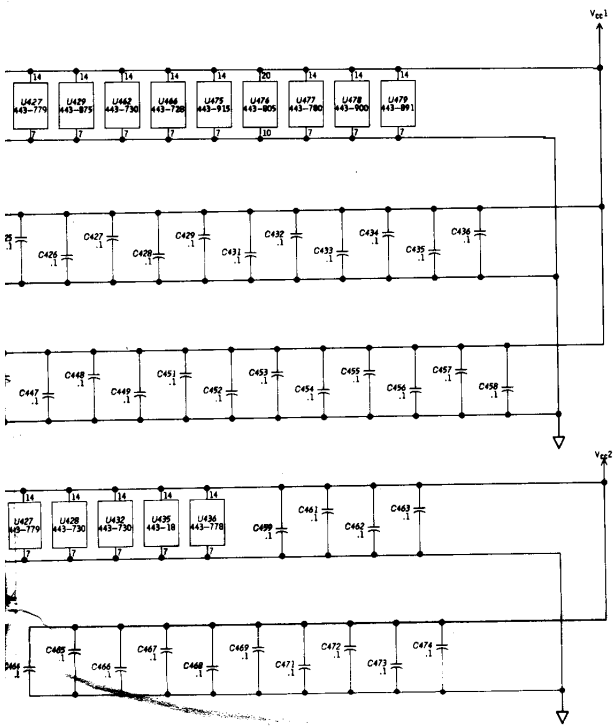

KEYBOARD

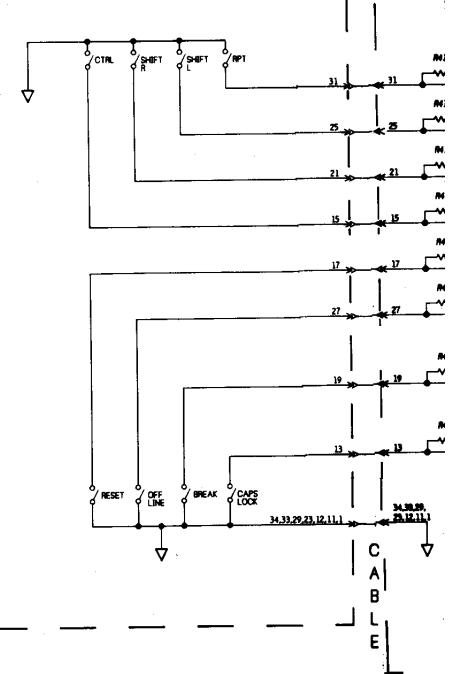

ADDRESS BUS

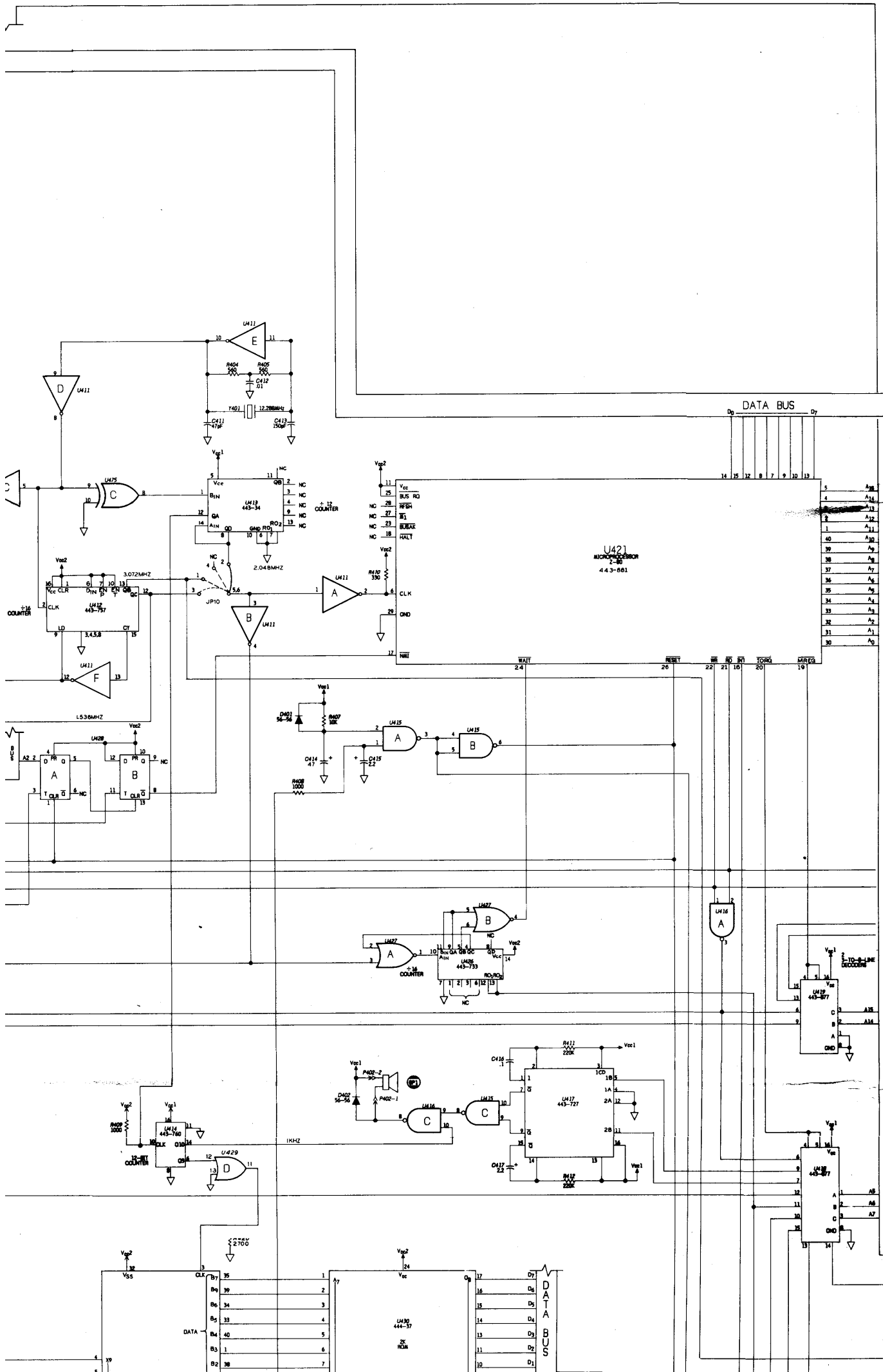



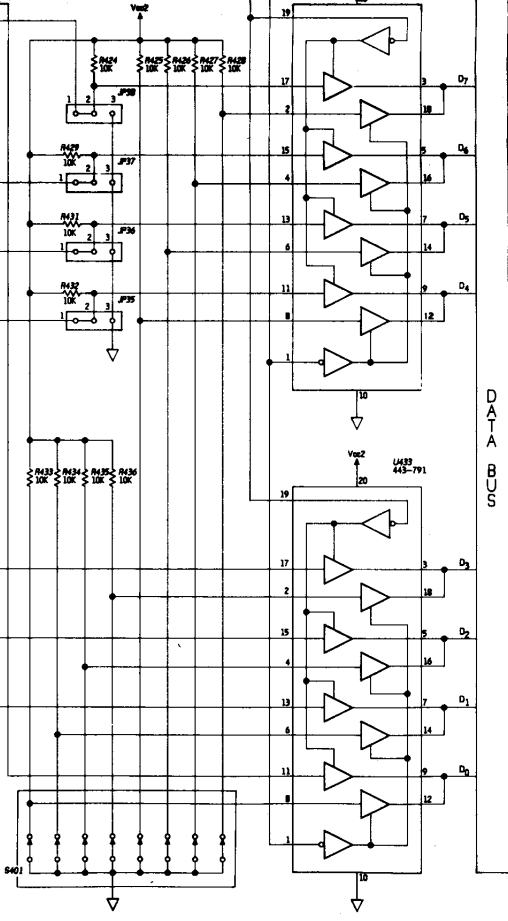
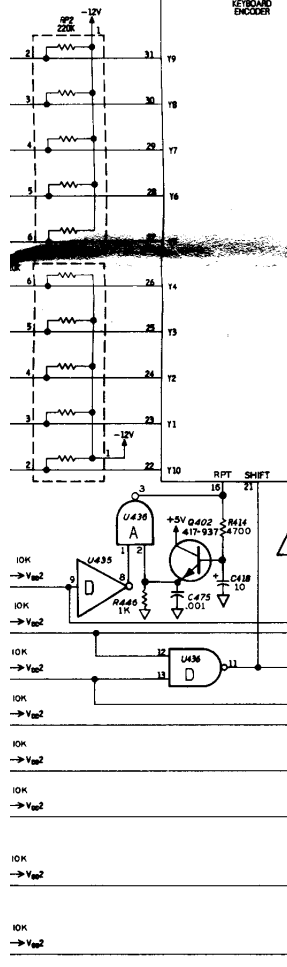
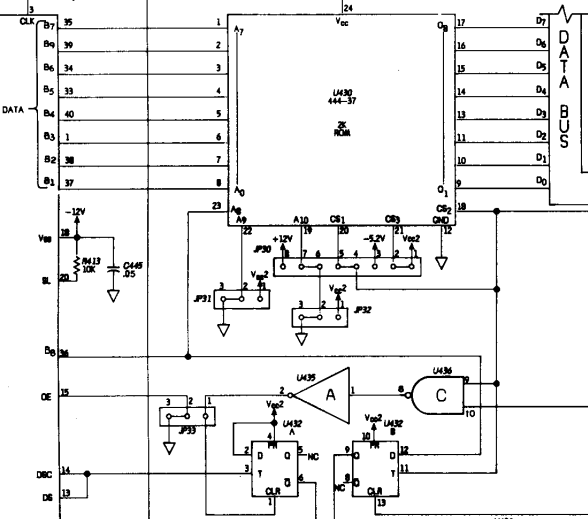
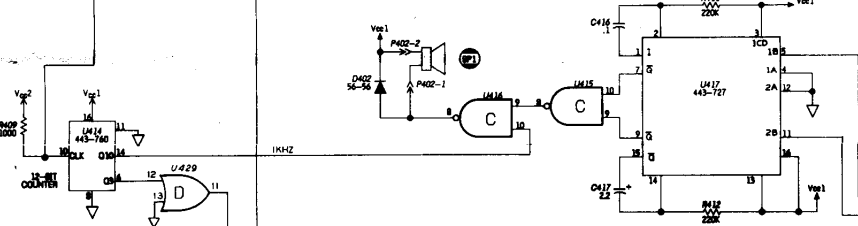
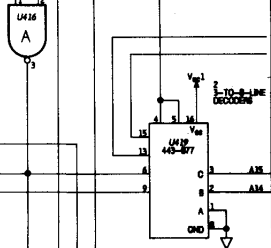
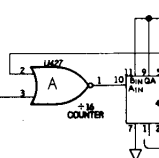
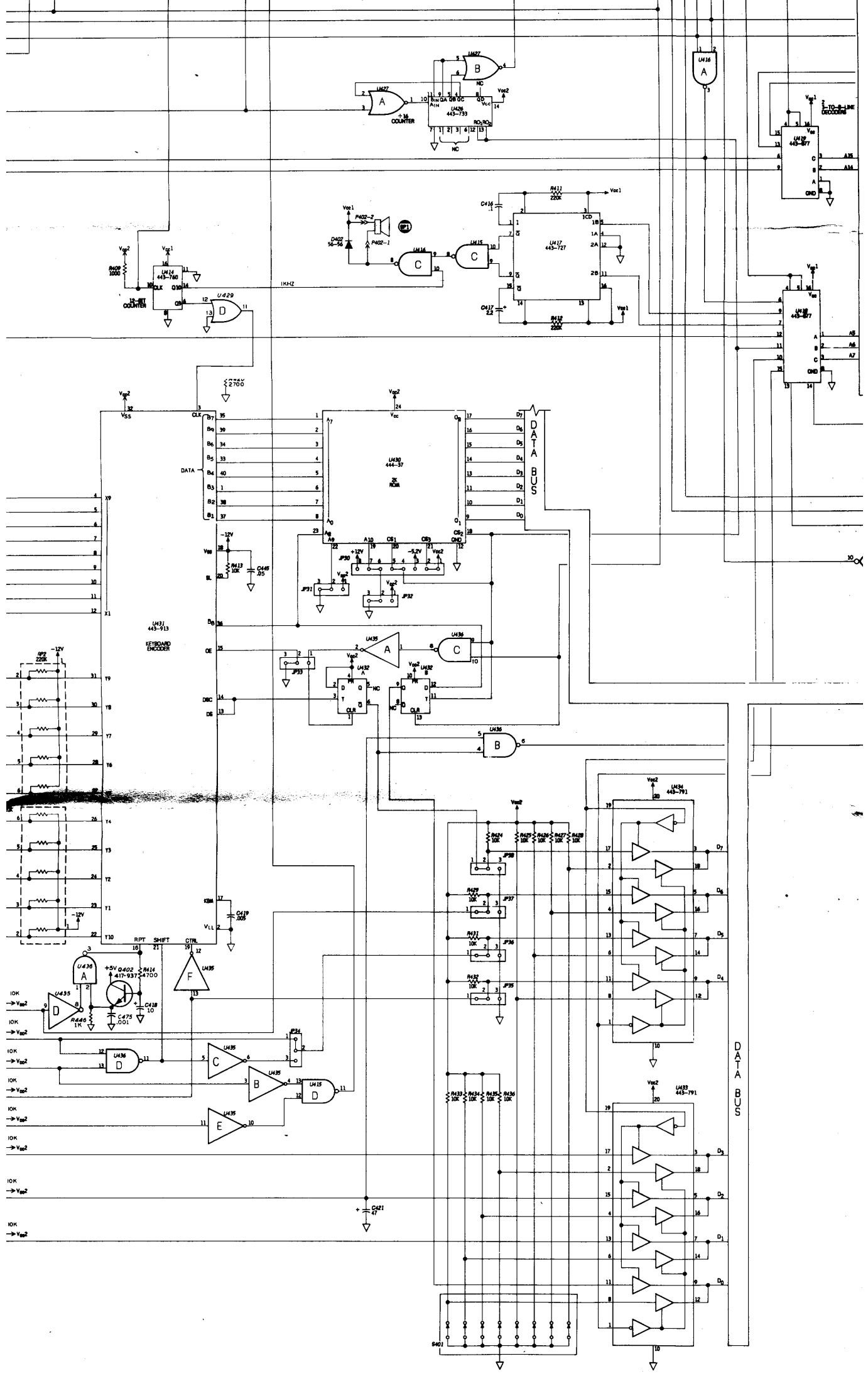

DATA BUS

TERMINAL LOGIC CIRCUIT BOARD

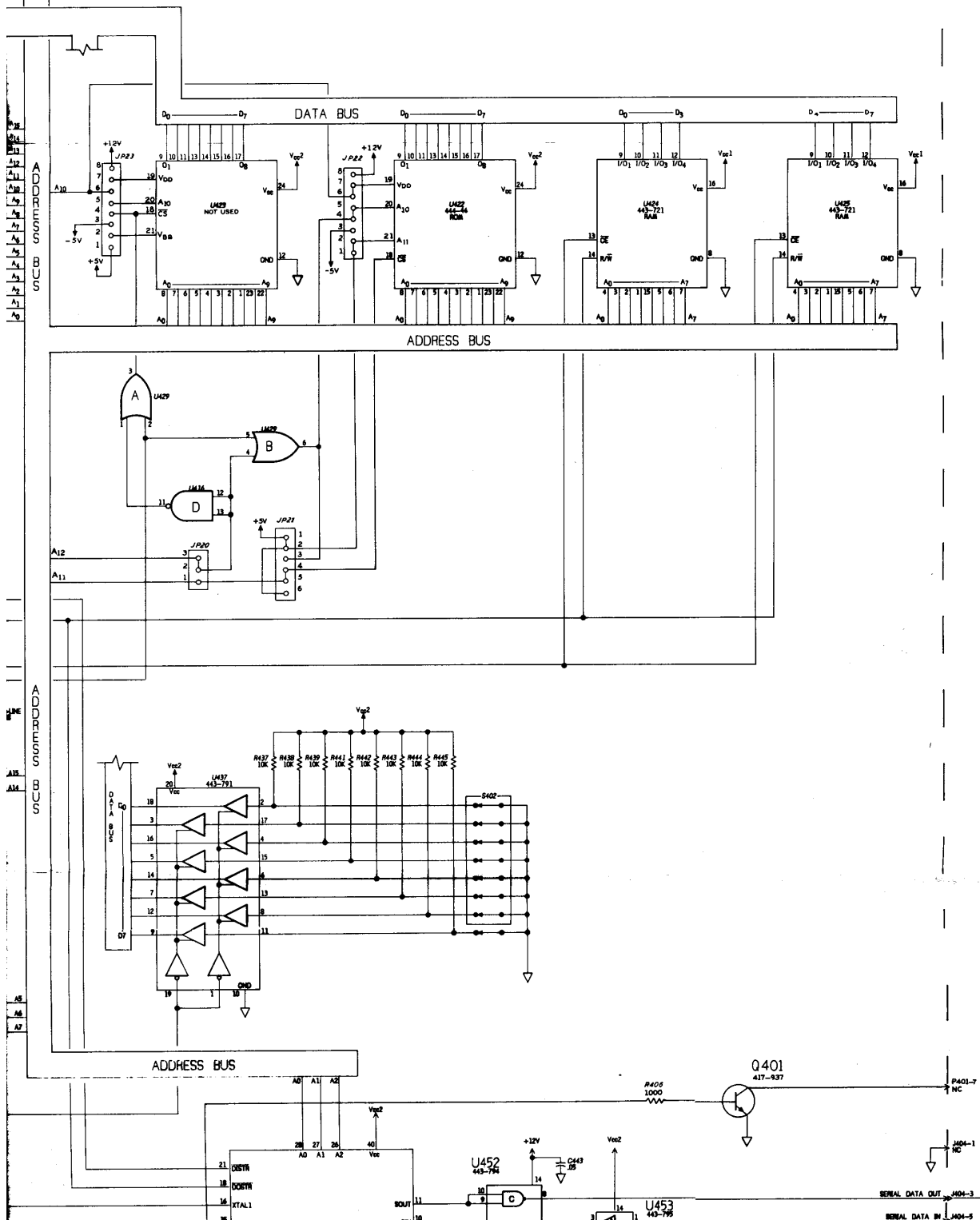

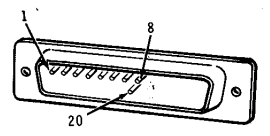
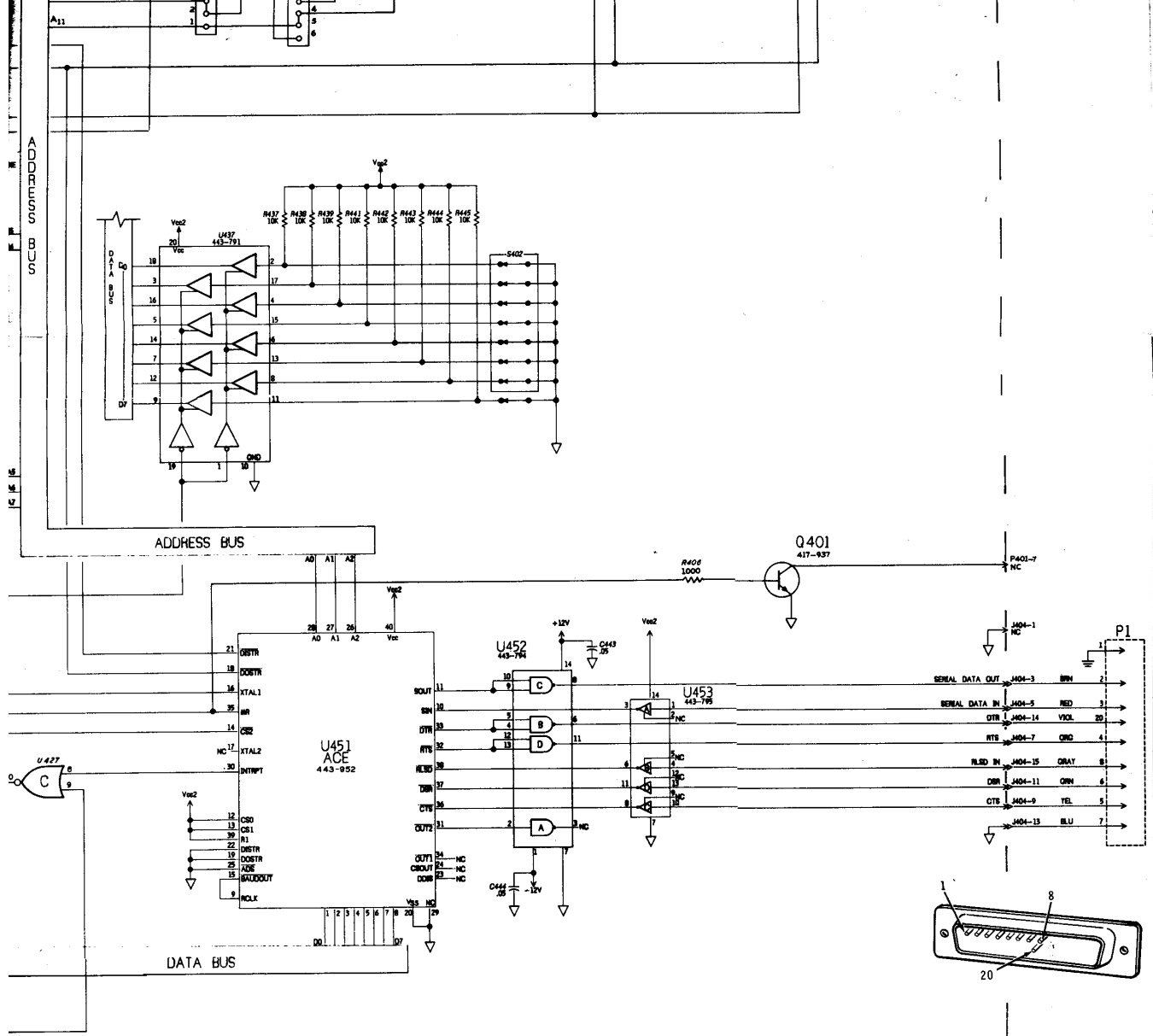

82-53-2

9782-58  
CORPORATION  
HEATH

U401

10

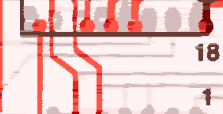
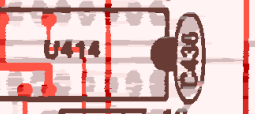
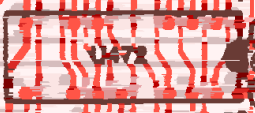
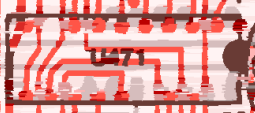
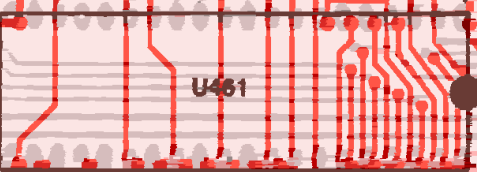

677090



# TERMINAL LOGIC C

(Viewed from the con

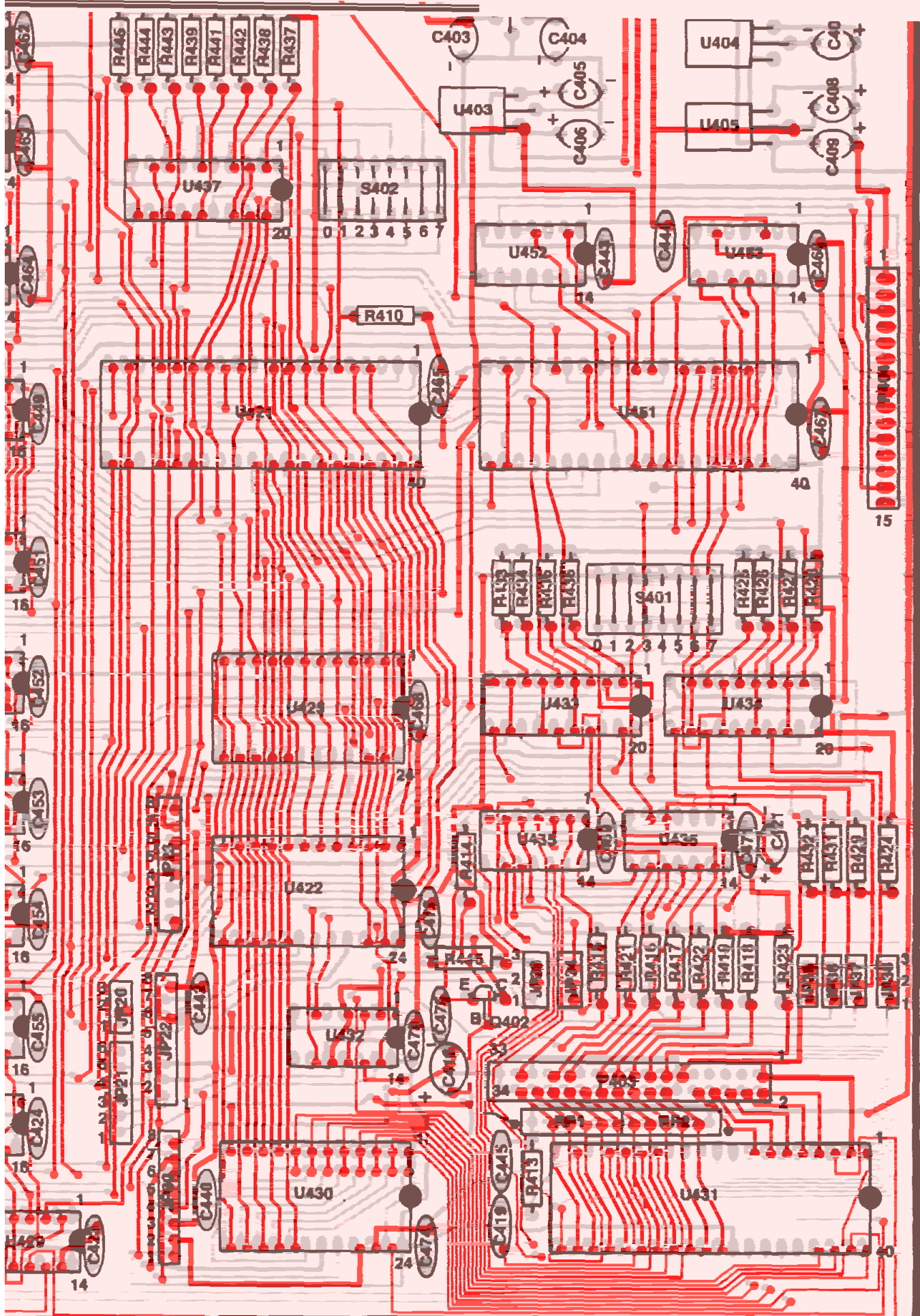

**CIRCUIT BOARD**  
 (component side)

# VIDEO

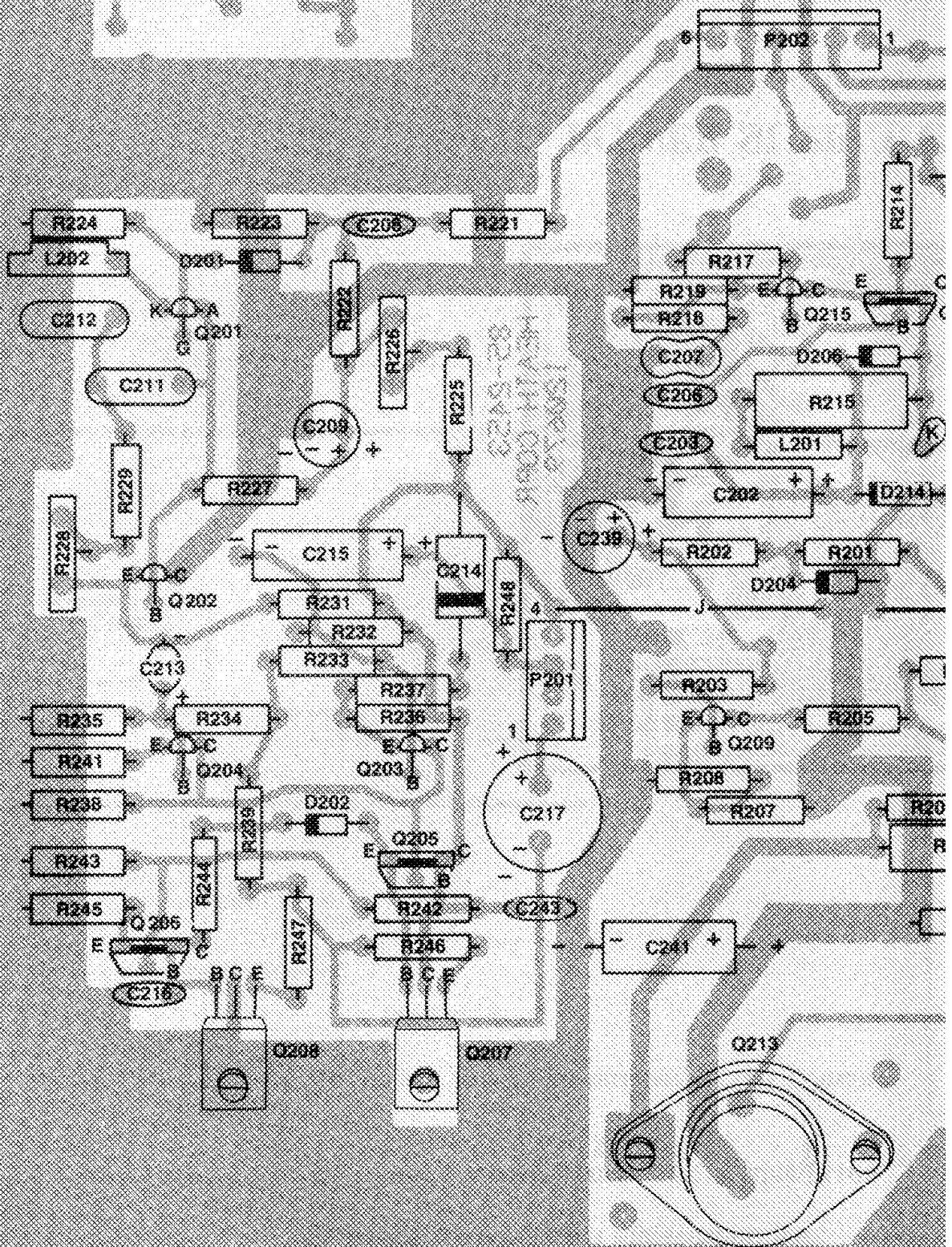
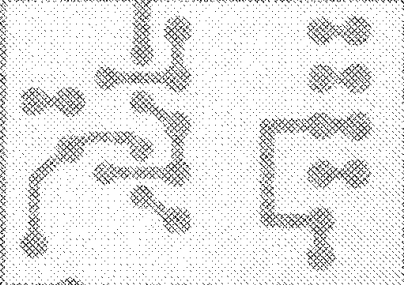

## VIDEO CIRCU

(Viewed from the o

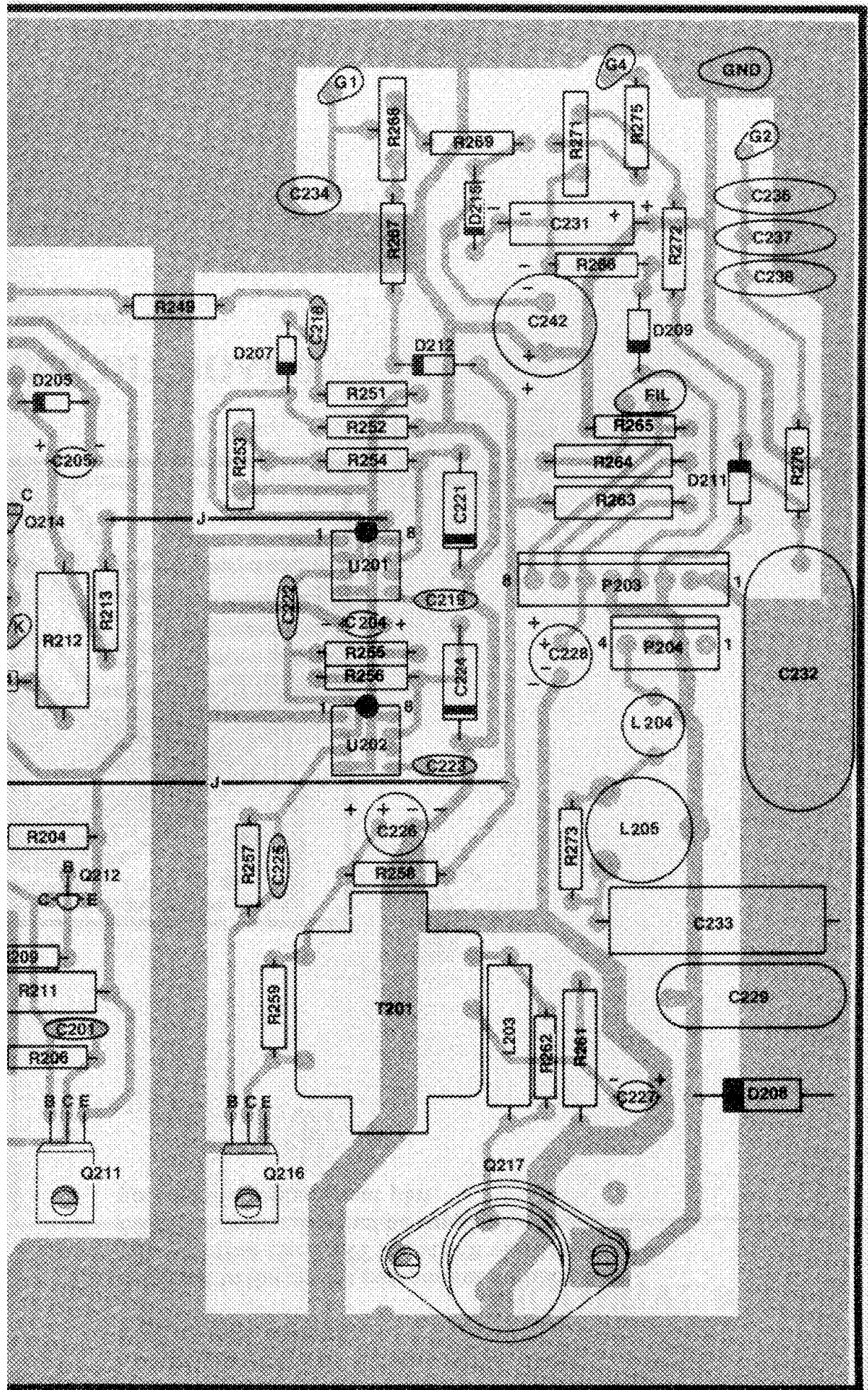

# UIT BOARD

(component side)

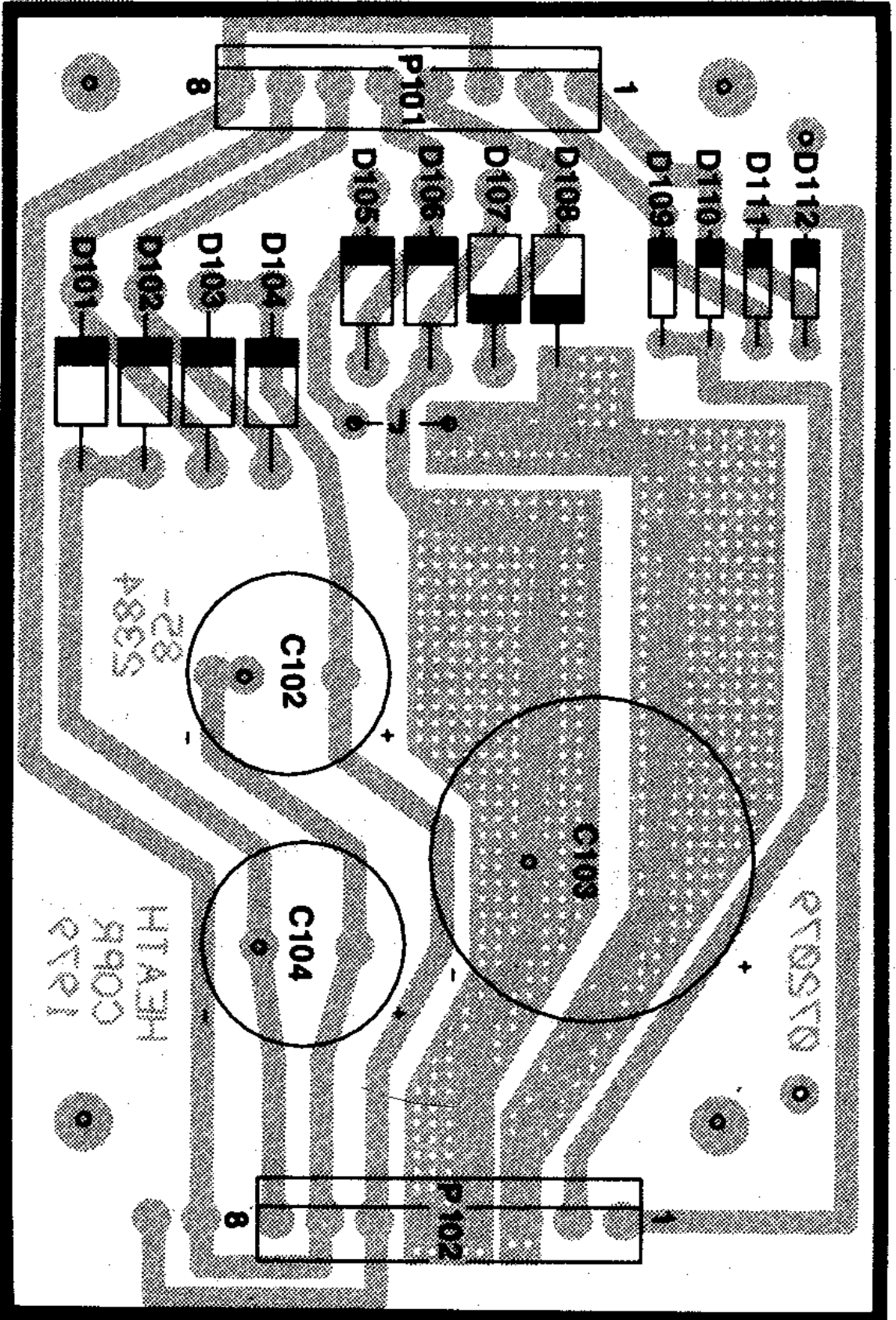

# POWER SUPPLY CIRCUIT BOARD

(Viewed from the component side)