

instructions

FOR THE



STATION SPEAKER

MODEL HS-1661

TABLE OF CONTENTS

Introduction	2
Parts List	2
Step-by-Step Assembly	4
Specifications	9
Warranty	10



INTRODUCTION

The Heathkit Model HS-1661 Station Speaker is an accessory unit for communications receivers. The speaker is a 5" x 7" oval type, mounted on a baffle board. A 5-foot shielded cable with a phono plug on the free end is wired to the speaker.

The cabinet color and design match that of the latest Heathkit Transceivers and Receivers. If you want to set the

Station Speaker on top of other equipment, and do not want to tilt the cabinet, you can remove the plastic foot spacers. Two #6 x 3/4" wood screws are provided so you can mount only the rubber feet on the cabinet front.

These features provide you with an attractive Station Speaker to use with your transceiver or receiver.

PARTS LIST

KEY No.	QTY.	DESCRIPTION	PART No.
CABINET-SPEAKER GRILLE			
A1 ()	1	Top cabinet half	90-1164-2
A2 ()	1	Bottom cabinet half	90-1165-2
A3 ()	1	Speaker grille	209-77-1
SPEAKER-BAFFLE BOARD			
()	1	Speaker	401-172
B1 ()	1	Baffle board	94-562
CLAMP-FEET-SPACER-PLUG			
C1 ()	1	Cable clamp	207-5
C2 ()	4	Rubber foot	261-9
C3 ()	2	Large spacer	255-59
C4 ()	2	Small spacer	255-716
C5 ()	1	Phono plug	438-4

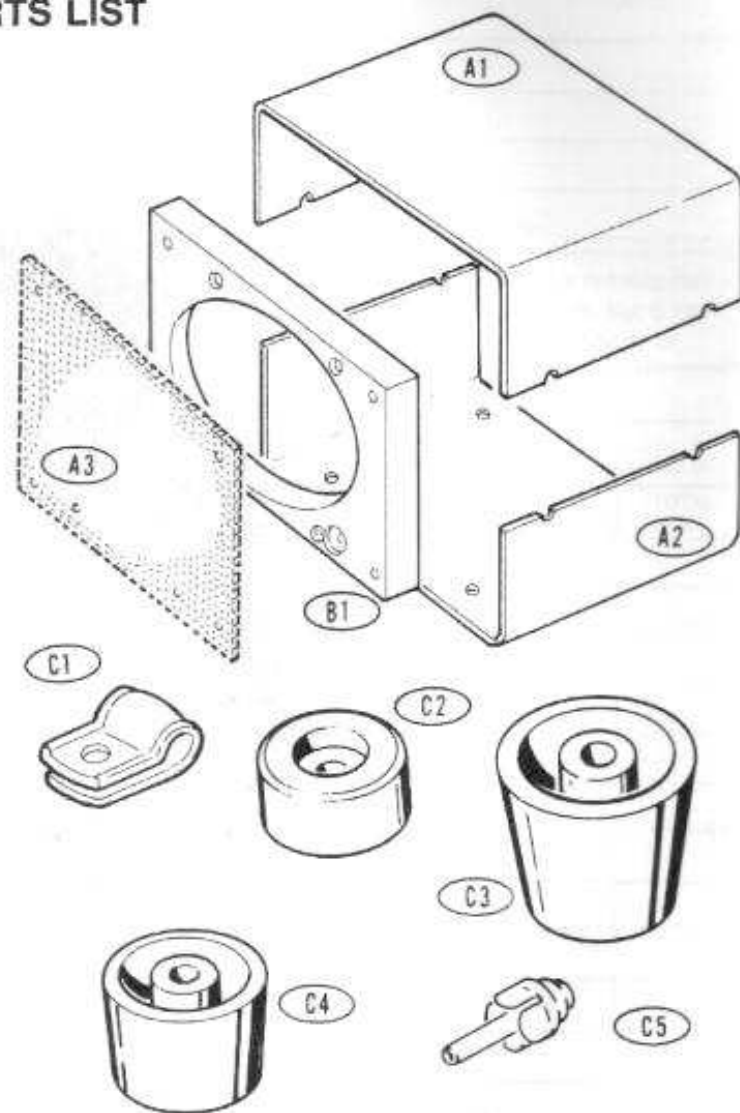

KEY No.	QTY.	DESCRIPTION	PART No.
---------	------	-------------	----------

HARDWARE

D1	() 2	#6 x 5/8" sheet-metal screw	250-12
D2	() 2	#6 x 3/4" wood screw	250-57
D3	() 2	6-32 x 1-1/4" screw	250-79
D4	() 2	6-32 x 3/8" screw	250-89
D5	() 4	6-32 x 7/8" phillips head screw	250-227
D6	() 2	#6 x 1-1/2" wood screw	250-388
D7	() 4	6-32 x 1-1/4" flat head screw	250-1187
D8	() 12	6-32 nut	252-3
D9	() 2	Speed Nut*	252-10
D10	() 2	Large #6 flat washer	253-21
D11	() 8	Small #6 flat washer	253-60
D12	() 1	"D" washer	253-89
D13	() 4	Felt washer	253-112
D14	() 12	#6 lockwasher	254-1

MISCELLANEOUS

E1	() 1'	Foam tape	73-39
E2	() 2	Trim plate	205-1588
	() 5'	Shielded cable	343-11
E3	() 1"	Sleeving	346-51
E4	() 1	Heathkit nameplate	391-96
E5	() 1	Blue and white label	391-34
	() 1	Kit Builder's Guide	597-308
	() 1	Parts Order Form	597-260
	() 1	Instruction sheet	
E6	() 1	Nut starter	490-5

Solder (Additional 3' rolls of solder can be ordered under part number 331-6 for \$.25 each.)

*Tinnerman Co., Registered Trademark

The prices shown on the separate "Heath Parts Price List" apply only on purchases from the Heath Company where shipment is to a U.S.A. destination. Add 10% (minimum 25 cents) to the price when ordering (Michigan residents add 4% sales tax) to cover insurance, postage, and handling. Outside the U.S.A., parts and service are available from your local Heathkit source and will reflect additional transportation, taxes, duties, and rates of exchange.

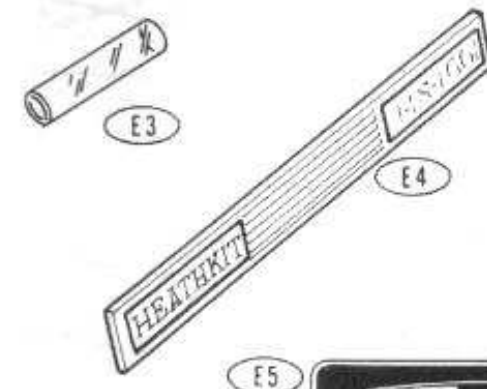
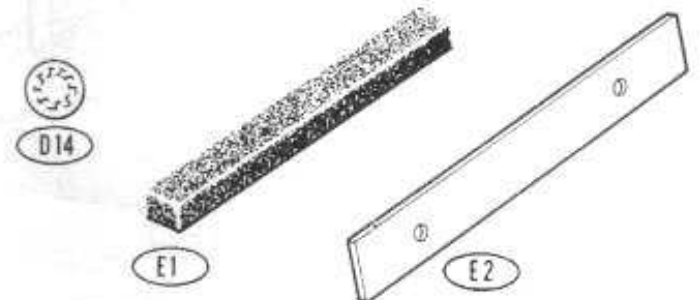
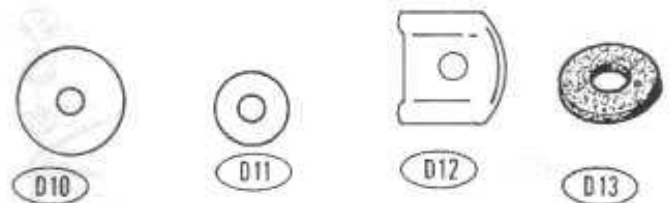

STEP-BY-STEP ASSEMBLY

Before you start to assemble this kit, read the wiring, soldering, and step-by-step assembly information in the "Kit Builders Guide."

SPEAKER MOUNTING

Refer to Pictorial 1 for the following steps.

CAUTION: The cone assembly and center dome of the speaker are quite fragile. Therefore, handle the speaker carefully and place it face down on a clean surface until it is installed. Be especially careful that you do not puncture the speaker cone when you install mounting screws.

- () Position the baffle board as shown.
- () Mount the speaker to the baffle board as shown. Use four 6-32 x 1-1/4" flat head screws, four small #6 flat

washers, four #6 lockwashers, and four 6-32 nuts. Be sure to position the speaker lugs as shown.

SPEAKER GRILLE MOUNTING

Refer to Pictorial 2 for the following steps.

Cut the following lengths of foam tape.

- () Two 1" lengths.
- () Two 3" lengths.

You may discard the remaining 4" length of foam tape.

- () Carefully peel away the protective backing from a 1" length of foam tape.

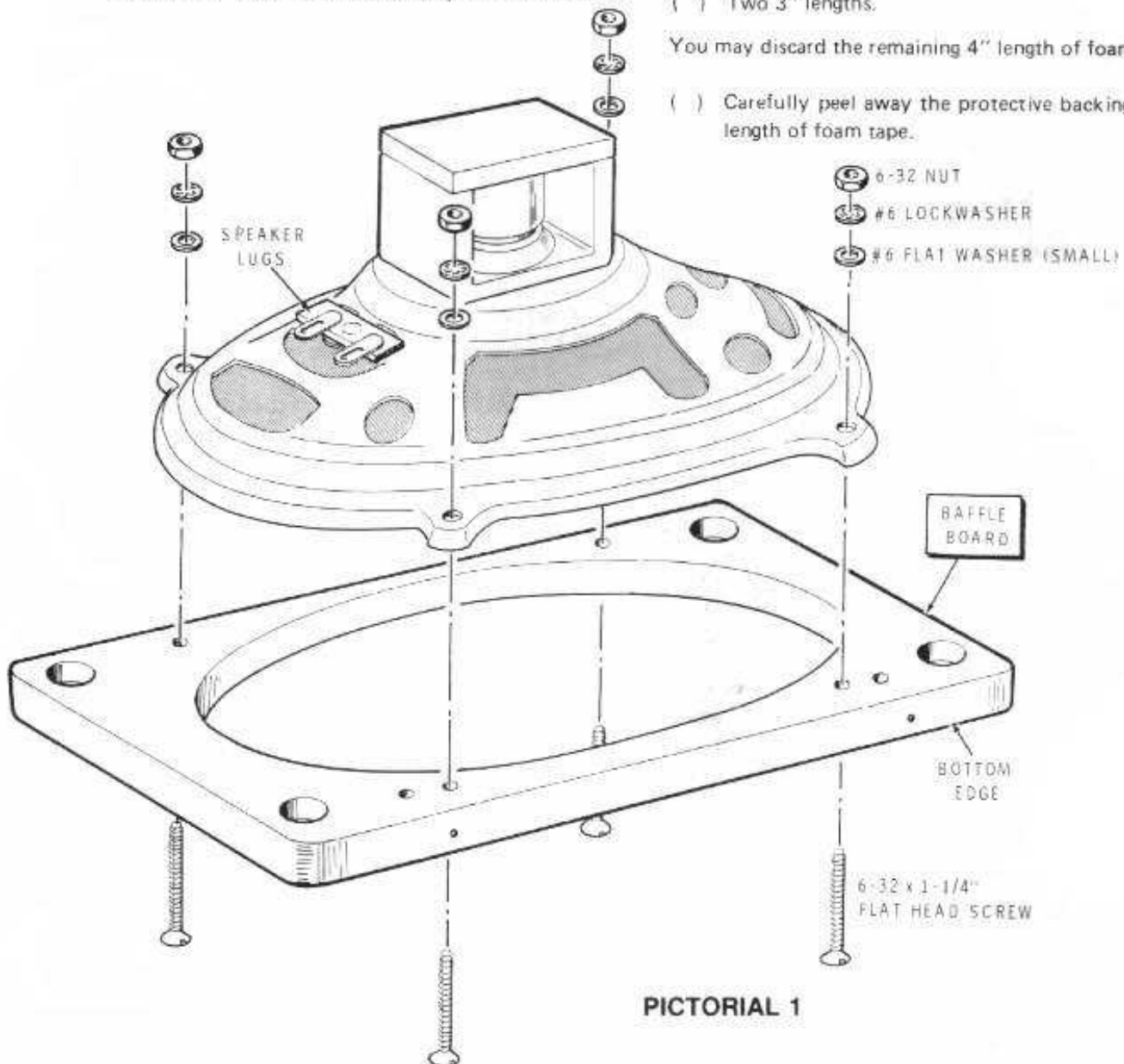

PICTORIAL 1

- () Press the 1" length of foam tape onto the front of the baffle board as shown.
- () In the same manner, install the remaining 1" length and 3" lengths of foam tape onto the baffle board as shown.
- () Carefully peel away the protective backing from a felt washer.
- () Press the washer onto the front of the baffle board as shown.
- () In the same manner, install the remaining three felt washers onto the baffle board as shown.
- () Refer to Detail 2A and install the Heathkit nameplate to the speaker grille with two speed nuts as shown. Push the speed nuts firmly onto the studs with the dish side toward the speaker grille as shown in the inset drawing.
- () Position the speaker grille and baffle board as shown.
- () Mount the speaker grille onto the front of the baffle board as shown. Use four 6-32 x 7/8" phillips head screws, four small #6 flat washers, four #6 lockwashers, and four 6-32 nuts. Do not overtighten these screws.

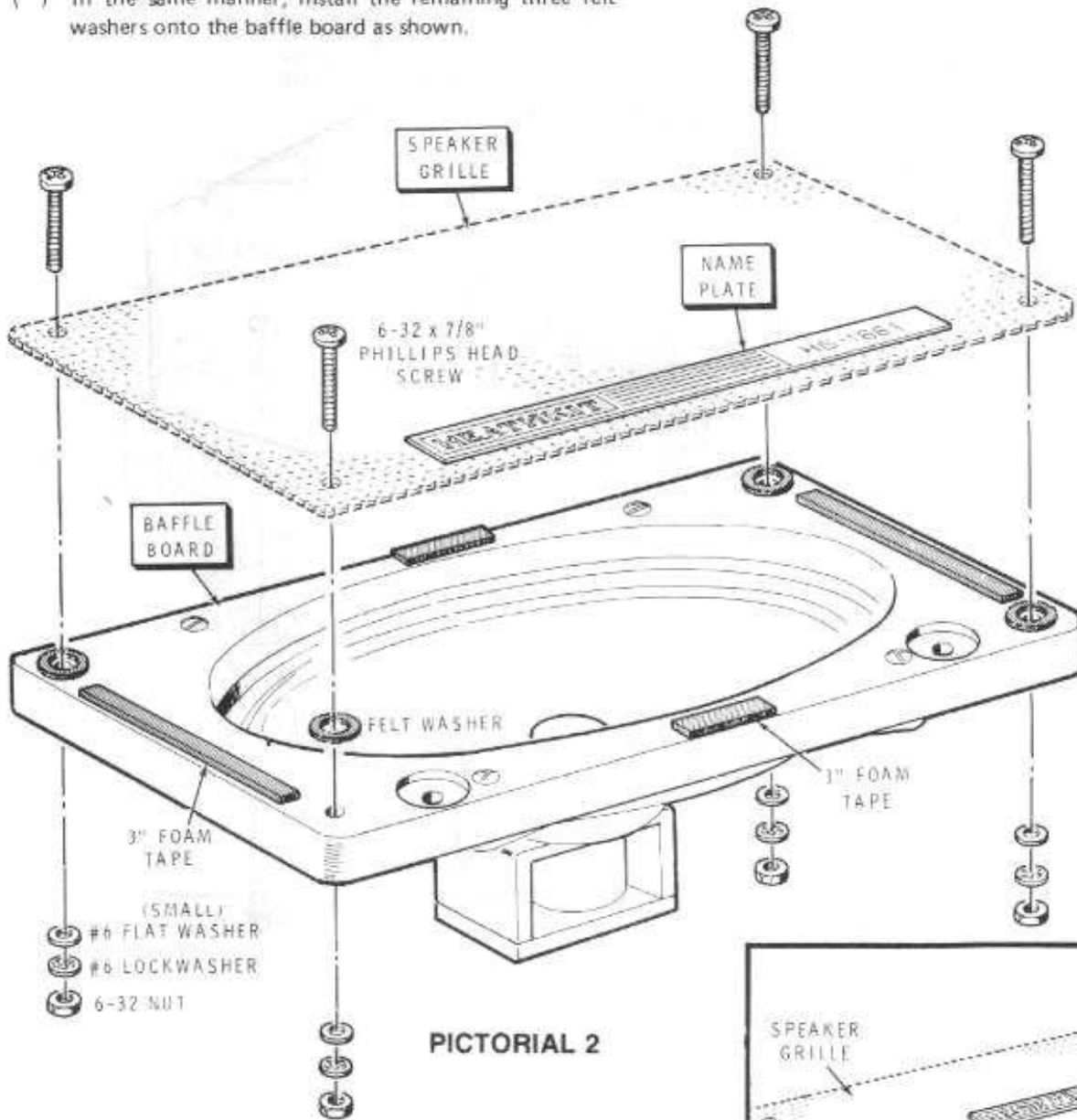

PICTORIAL 2

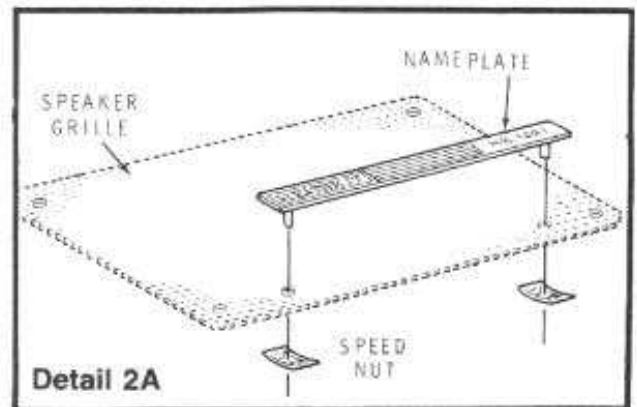

Detail 2A



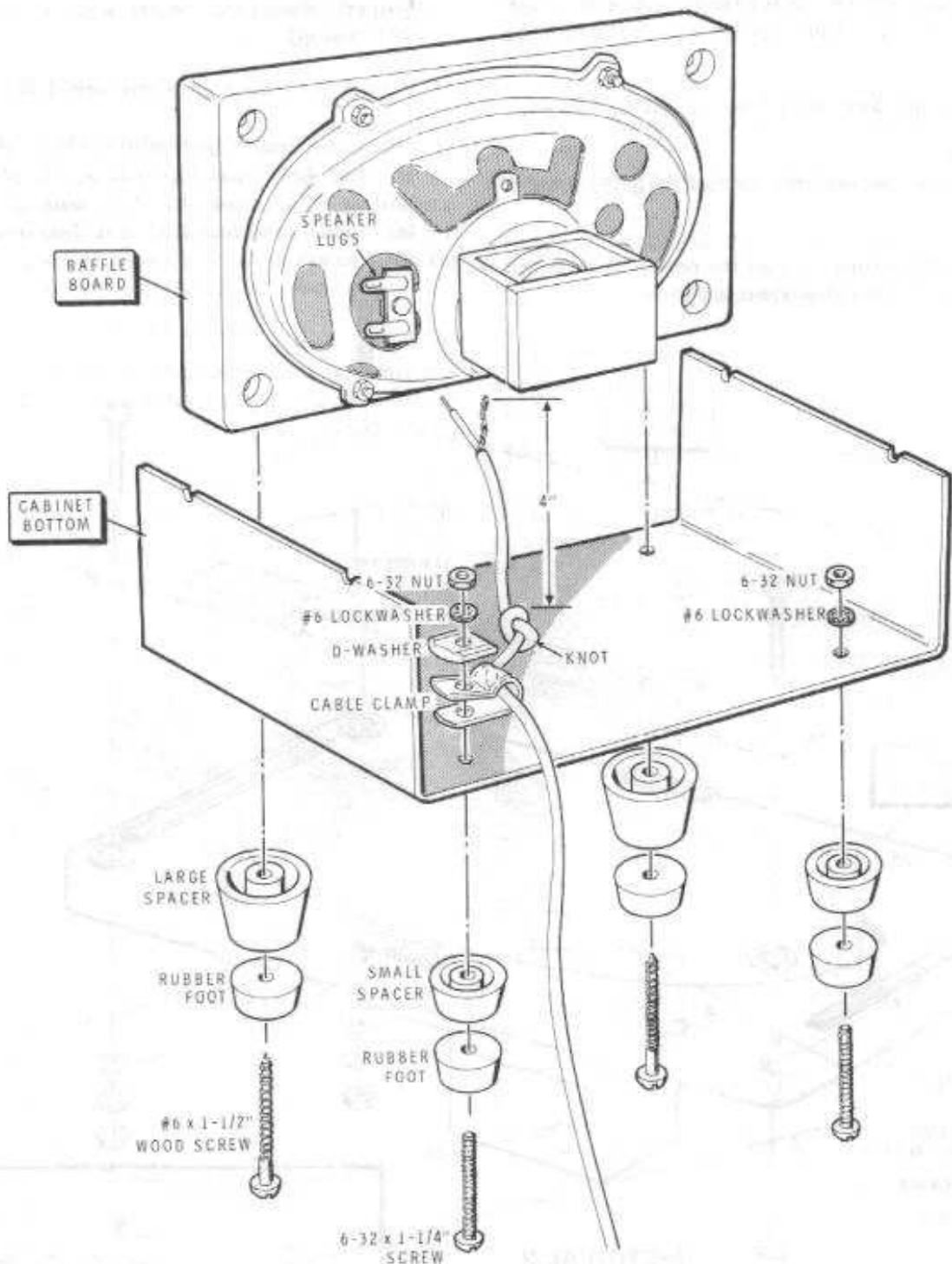

PICTORIAL 3

BAFFLE BOARD MOUNTING

Refer to Pictorial 3 for the following steps.

- () Mount the baffle board, two large spacers, and two rubber feet to the bottom cabinet half as shown. Use two #6 x 1-1/2" wood screws. Do not overtighten these screws. **NOTE:** If you want to mount the rubber feet without the large spacers, use two #6 x 3/4" wood screws instead of #6 x 1-1/2" screws.
- () Refer to Detail 3A and prepare the ends of the shielded cable as shown.

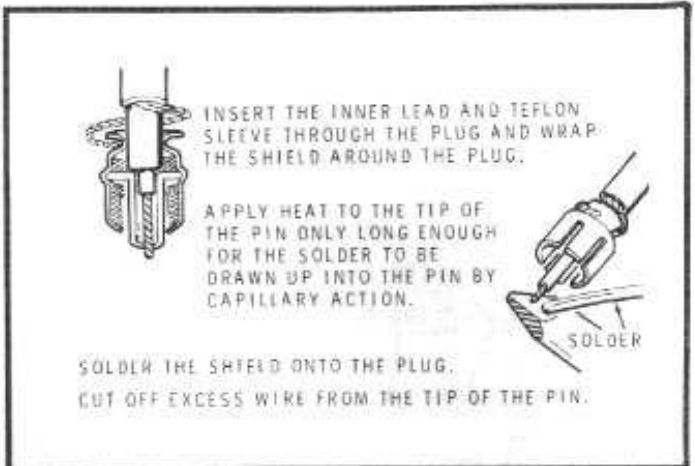

Detail 3B

- () Refer to Detail 3B and install a phono plug on one end of the shielded cable as shown.
- () Tie a knot in the shielded cable 4" from the end without the phono plug as shown.
- () Slip the cable clamp over the shielded cable just behind the knot as shown.
- () Mount the cable clamp, a small spacer, and a rubber foot to the bottom cabinet half as shown. Use a 6-32 x 1-1/4" screw, a "D" washer, a #6 lockwasher, and a 6-32 nut.
- () Mount a small spacer and a rubber foot to the bottom cabinet half as shown. Use a 6-32 x 1-1/4" screw, a #6 lockwasher, and a 6-32 nut.

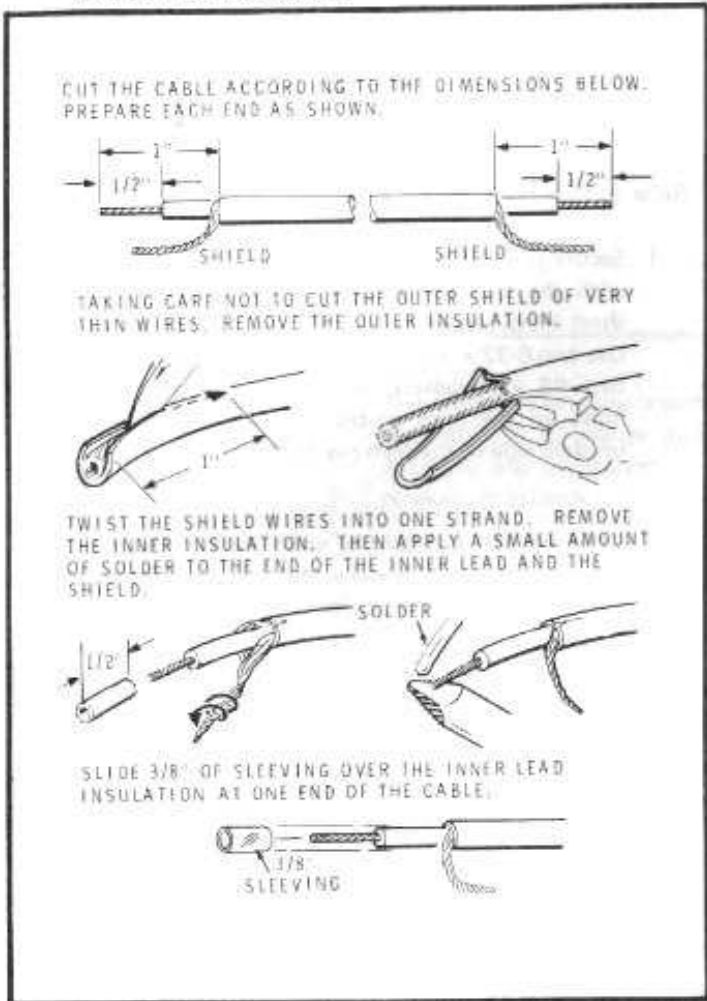

Detail 3A



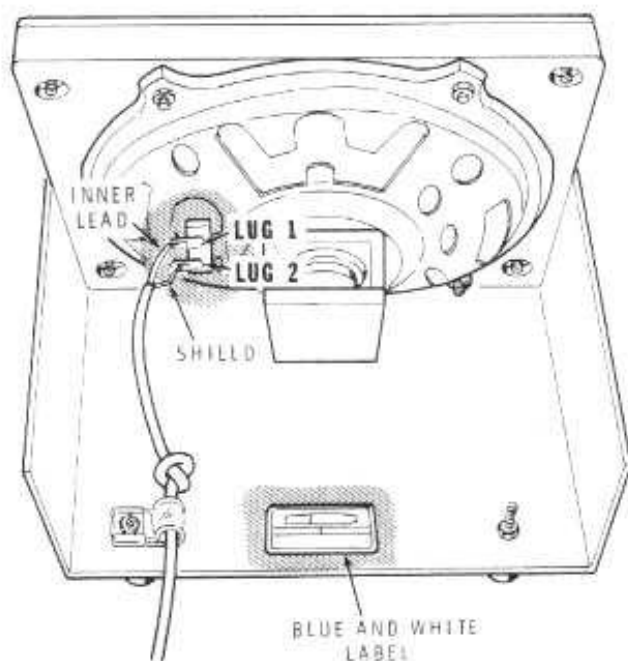

PICTORIAL 4

SPEAKER WIRING AND FINAL ASSEMBLY

Refer to Pictorial 4 for the following steps.

- () Connect the shield lead of the shielded cable to speaker terminal strip, lug 2. Solder the lead to the lug.

- () Connect the center lead of the shielded cable to speaker terminal strip, lug 1. Solder the lead to the lug.

NOTE: The blue and white label shows the model number and production series number of your kit. Refer to these numbers in any communications you may have with the Heath Company about this kit. This assures you that you will receive the most complete and up-to-date information in return.

- () Carefully peel away the paper backing from the blue and white label. Then press the label onto the bottom cabinet half as shown.

Refer to Pictorial 5 for the following steps.

- () Secure the top cabinet half to the bottom cabinet half with the trim plates as shown. Use two #6 x 5/8" sheet metal screws in the front holes in the trim plates. Use two 6-32 x 3/8" screws, two large #6 flat washers, two #6 lockwashers, and two 6-32 nuts in the rear holes in the trim plates. Be sure to position the brushed side of the trim plates to the outside.

This completes the assembly of your Station Speaker. You will have two #6 x 3/4" wood screws left over. They can be used to mount only the rubber feet to the cabinet front.

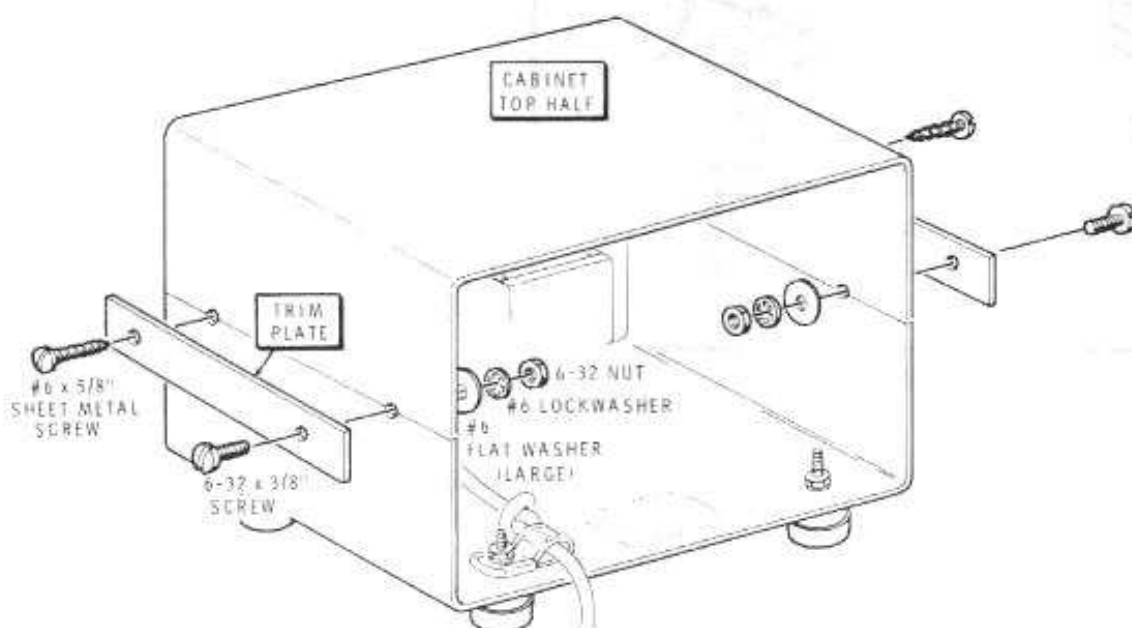

PICTORIAL 5

SPECIFICATIONS

Speaker Size	5" x 7" oval.
Impedance	3.5 ohms.
Frequency Response	300 to 3000 Hz.
Magnet Weight	3.16 oz.
Cabinet	Aluminum, green spatter finish.
Dimensions	9" wide x 6-5/8" wide x 5-5/8" deep.
Net Weight	3-1/4 lbs.

The Heath Company reserves the right to discontinue products and to change specifications at any time without incurring any obligation to incorporate new features in products previously sold.