

Assembly  
and  
Operation  
of the



CW TRANSMITTER  
MODEL HX-11



HEATH COMPANY,  
BENTON HARBOR,  
MICHIGAN

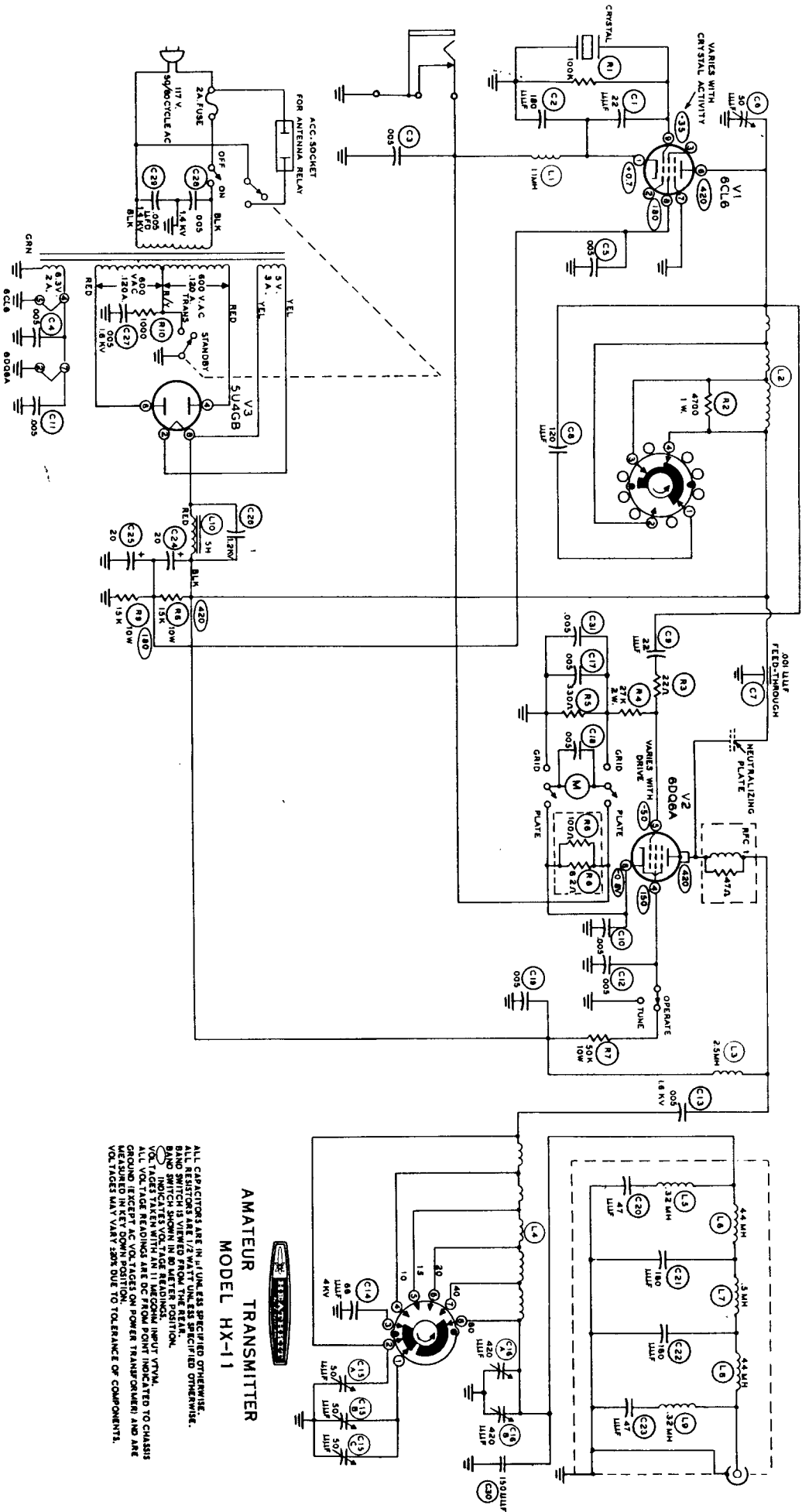

TABLE OF CONTENTS

Specifications. . . . .	2
Introduction. . . . .	2
Circuit Description. . . . .	3
Construction Notes. . . . .	3
Parts List. . . . .	4
Proper Soldering Techniques. . . . .	7
Schematic. . . . .	7*
Step-By-Step Procedure. . . . .	8
Step-By-Step Assembly. . . . .	9
Mechanical Assembly-Chassis	
Bottom. . . . .	9
Low-Pass Filter Assembly. . . . .	12
Oscillator, Front Panel Assembly	
And Wiring. . . . .	13
Front Panel Mounting And	
Under-Chassis Wiring. . . . .	18
Final Wiring Chassis Top. . . . .	22
Preliminary Check. . . . .	24
Installation. . . . .	24
CW Operation. . . . .	25
Final Assembly. . . . .	26
In Case Of Difficulty. . . . .	27
Service Information. . . . .	27
Service. . . . .	27
Replacements. . . . .	29
Shipping Instructions. . . . .	29
Warranty. . . . .	30

\*Fold-out from page.

All prices are subject to change without notice. The Heath Company reserves the right to discontinue instruments and to change specifications at any time without incurring any obligation to incorporate new features in instruments previously sold.



### AMATEUR TRANSMITTER MODEL HX-11

ALL CAPACITORS ARE IN MICROFARADS UNLESS SPECIFIED OTHERWISE.  
ALL RESISTORS ARE 1/2 WATT UNLESS SPECIFIED OTHERWISE.  
BAND SWITCH IS VIEWED FROM THE REAR.  
VOLTAGES TAKEN WITH AN 11 MEGOHM INPUT IMPEDANCE TUBE.  
ALL VOLTAGE READINGS ARE DC FROM POINT INDICATED TO CHASSIS GROUND, EXCEPT AC VOLTAGES ON POWER TRANSFORMER AND ARE MEASURED IN KEY DOWN POSITION TO TOLERANCE OF COMPONENTS.  
VOLTAGES MAY VARY SOME DUE TO TOLERANCE OF COMPONENTS.



## SPECIFICATIONS

Power Input. . . . .	50 watts.
Output Impedance. . . . .	50-75 $\Omega$ .
Output Coupling. . . . .	Pi network (coaxial).
Operation. . . . .	CW.
Frequency Control. . . . .	Crystal or external VFO.
Band Coverage. . . . .	80, 40, 20, 15, and 10 meters.
Front Panel Controls. . . . .	GRID-PLATE meter switch. BAND SWITCH. OSCILLATOR tune control. AMPLIFIER tune control. TRANSMIT-STANDBY switch. OPERATE-TUNE switch. LOADING control. OFF-ON switch.
Tube Complement. . . . .	1 - 6CL6 Oscillator. 1 - 6DQ6A Final amplifier. 1 - 5U4GB Rectifier.
Power Requirements. . . . .	117 volts, 50/60 cps AC, 160 watts.
Cabinet Size. . . . .	13" wide x 8-3/4" high x 7" deep.
Net Weight. . . . .	16 lbs.
Shipping Weight. . . . .	18 lbs.

## INTRODUCTION

The HEATHKIT Model HX-11 CW Transmitter was designed as an economical transmitter for General and Novice Class amateur operation. It features up to 50 watts input for crystal-controlled CW operation on the 80, 40, 20, 15, and 10 meter bands.

All operating controls and the easy-to-read grid-plate meter are conveniently located on the front panel. An AC power outlet is provided on the rear of the Transmitter for 117 V AC antenna relay operation.

## CIRCUIT DESCRIPTION

The HX-11 Transmitter has three basic sections: the oscillator, final amplifier, and power supply. It will be helpful to refer to the Schematic Diagram while reading the Circuit Description.

Oscillator tube V1 is used in an efficient and proven Colpitts circuit. This type of circuit produces full grid drive on fundamental and harmonic frequencies, allowing the final amplifier to operate at maximum output efficiency.

A very small signal voltage, at a frequency determined by the crystal used, appears at the grid of the oscillator tube. This voltage is then greatly amplified and applied to the tuned plate circuit consisting mainly of coil L2 and variable capacitor C6. The coil and capacitor combination can be tuned to the fundamental frequency of the crystal or to one of its multiples, or harmonics.

A VFO can be used with the transmitter by using a suitable input adapter, and plugging it into the crystal socket. The VFO must, however, be powered from a source other than the Transmitter.

This amplified RF energy is capacitively coupled to the grid of final amplifier tube V2. Again, the signal is greatly amplified, and appears in the final tank circuit, consisting of C14, C15A, B, C, and L4. The use of a two section variable loading capacitor, C16A, B, eliminates the necessity of switching fixed capacity into or out of the circuit when changing bands.

The output of V2 is applied to a low-pass filter, consisting of coils L5 through L9 and capacitors C20 through C23. The low-pass filter has a cutoff frequency of approximately 34 megacycles, and suppresses RF energy above this frequency. The output should be fed into an unbalanced 50 to 75  $\Omega$  line.

The power supply utilizes a full-wave tube-type rectifier to deliver 500 volts at 100 milliamperes to the final amplifier. It is designed with an AF choke input, along with filter capacitors C24 and C25 in series to provide a ripple-free DC output. Resistors R8 and R9 serve as a bleeder as well as a voltage divider for obtaining screen voltage for the oscillator. To further improve regulation and limit surge voltage under key-up conditions, capacitor C26 is connected in parallel with filter choke L10.

## CONSTRUCTION NOTES

This manual is supplied to assist you in every way to complete your kit with the least possible chance for error. The arrangement shown is the result of extensive experimentation and trial. If followed carefully, the result will be a stable instrument, operating at a high degree of dependability. We suggest that you retain the manual in your files for future reference, both in the use of the instrument and for its maintenance.

**UNPACK THE KIT CAREFULLY AND CHECK EACH PART AGAINST THE PARTS LIST.** In so doing, you will become acquainted with the parts. Refer to the charts and other information on the inside covers of the manual to help you identify the components. If some shortage or parts damage is found in checking the Parts List, please read the Replacement section and supply the information called for therein. Include all inspection slips in your letter to us.

Resistors generally have a tolerance rating of 10% unless otherwise stated in the Parts List. Tolerances on capacitors are generally even greater. Limits of +100% and -20% are common for electrolytic capacitors.

We suggest that you do the following before work is started:

1. Lay out all parts so that they are readily available.
2. Provide yourself with good quality tools. Basic tool requirements consist of a screwdriver with a 1/4" blade; a small screwdriver with a 1/8" blade; long-nose pliers; wire cutters, preferably separate diagonal cutters; a pen knife or a tool for stripping insulation from wires; a soldering iron (or gun) and rosin core solder. A set of nut drivers and a nut starter, while not neces-

- (✓) Turn the shafts extending from the OSCIL-LATOR and AMPLIFIER holes of the front panel fully counterclockwise.
- (✓) Install a large pointer knob on each of these shafts and tighten the setscrews so the knob pointers are at 0.
- (✓) Install small pointer knobs on the BAND SWITCH and LOADING shafts. Tighten LOADING knob at "O", and the BAND knob at 80.
- ( ) Locate the brass plate and form it around something (broom handle) that is 3/4" in diameter. See Detail 7A.
- (✓) Refer to Pictorial 7 and fit the hole in the brass plate on the end of the feed-through capacitor at DD and solder in place.
- (✓) Install the tubes in their respective sockets, and connect the plate cap to the top of the 6DQ6A. See Pictorial 7. Use care when installing the 6DQ6A tube so as not to

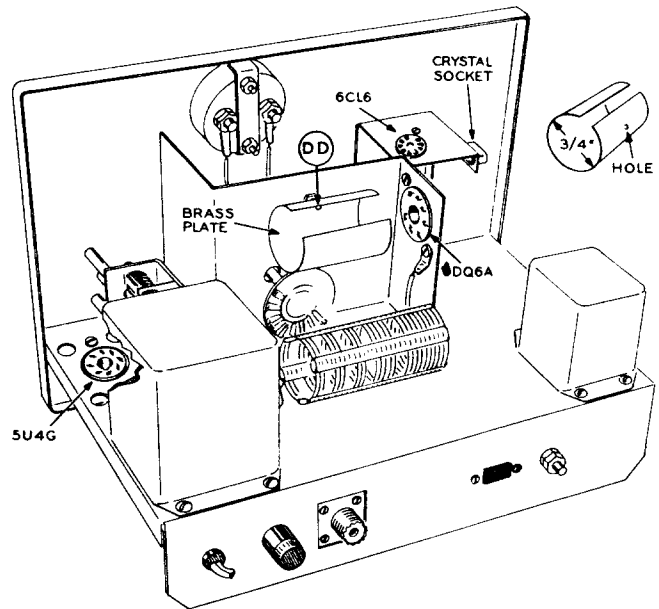

Pictorial 7

break loose the brass neutralizing plate when sliding the tube into the plate.

- ( ) Install a fuse in the fuse holder.

## PRELIMINARY CHECK

- (✓) Do not plug the Transmitter into an AC power outlet until the following paragraph has been read carefully.

If at all possible, it is advisable to make a resistance check of the high voltage circuitry before turning the Transmitter on. This is done

by measuring the resistance between the plate cap of the 6DQ6A tube and the chassis. After allowing a few seconds for the ohmmeter to stabilize, a reading of near 30,000  $\Omega$  should be obtained. If a reading much lower than 30,000  $\Omega$  is obtained, refer to the In Case Of Difficulty section of the manual.

## INSTALLATION

**NOTE:** It should be noted that an Amateur Radio Operator and Station License is required to place this Transmitter on the air. Information regarding licensing and amateur frequency allocations may be obtained from publications of the Federal Communications Commission or the American Radio Relay League.

### ANTENNAS

The pi network output circuit of the HX-11 will match pure resistive loads of 50 to 75  $\Omega$ .

The simplest type of antenna that falls into this impedance range is the "dipole," constructed so that its length is 1/2 wave at the frequency of operation. The 50 to 75  $\Omega$  impedance range also covers other "home brew" antennas such as beams, verticals, and trapped antennas.

A half-wave, end-fed antenna for a given band presents too high an impedance and is not recommended without an antenna tuner. Balanced antenna systems should be fed through an antenna coupler so that neither leg of the line nor the antenna will be at ground potential. Normally the output of the transmitter is unbalanced since one side of the output circuit is grounded.

Much has been published on this subject of antennas and excellent articles can be found in the ARRL Handbook, Radio Handbook, and in most issues of CQ and QST magazines.

### CRYSTALS

The Transmitter may be operated satisfactorily using the following crystals:

Band	Fundamental Crystals
80 meters	160 or 80 meter crystals
40 meters	80 or 40 meter crystals
20 meters	80 or 40 meter crystals
15 meters	40 meter crystals
10 meters	40 meter crystals

Pin spacing .486" Pin size .093 dia.

**NOVICE** operation imposes restrictions on operating frequencies as follows:

Band	Frequency
80 Meters	3700-3750 kc
40 Meters	7150-7200 kc
15 Meters	21,100-21,250 kc

Crystal frequency limits for Novice operation:

Band	Frequency
80 Meters	3700-3750 kc
40 Meters	7150-7200 kc
15 Meters	7033,333-7083,333 kc

**CAUTION:** Be sure to check the latest FCC regulations on frequency allocations and power input requirements. When ordering crystals be sure to stay well within amateur band edge limits to avoid violations.

## C W OPERATION

1. Set the front panel controls as follows:  
ON-OFF switch to OFF.  
TRANSMIT-STANDBY switch to STANDBY.  
LOADING to 0.  
OPERATE-TUNE switch to TUNE.  
BAND SWITCH to desired band.  
Meter switch to GRID.  
AMPLIFIER to approximately 5.
2. Insert your key plug into the front panel KEY jack, with key contacts open.
3. Connect the 117 V AC antenna relay solenoid terminals to the ANT RELAY socket on the rear apron (if used).
4. Connect your antenna to the RF OUTPUT

Beware of so-called bargain crystals. The greatest cause of poor keying will lie in using poor crystals or from dirty key contacts. Always buy crystals from reputable suppliers. Furnish them with a schematic of the oscillator circuit to be sure of getting proper crystals.

### VFO

An external variable frequency oscillator may be used, providing that a separate power supply is employed for it.

When using a VFO, a jumper wire must be connected across the RF choke in the cathode circuit of the 6CL6 oscillator stage. To key the VFO with the transmitter, the cathode of the VFO tube should be connected to key jack lug 3, and the chassis of the VFO must be grounded to the Transmitter chassis. A plug to connect the VFO to the crystal socket of the Transmitter can be made from an old crystal holder or a twin lead connector. Note: The grounded side of the crystal socket, which is the left side, should be connected to the ground side of the VFO coax cable.

### ANTENNA RELAY

The AC outlet on the rear of the Transmitter provides 117 volts AC to operate an antenna relay. This outlet is connected into the Transmitter circuit as shown on the Schematic Diagram. Do not connect a DC relay, or an AC relay intended for operation on other than 117 volts, to this socket.

coaxial jack on the rear apron, or to a coaxial antenna relay if used (in this case it will be necessary to supply an additional connection from the relay to the transmitter).

5. Connect the ground connection to the GND lug on the rear apron.
6. Plug the line cord into a 117 V AC 50/60 cps outlet.
7. Plug the appropriate crystal into the crystal socket. **WARNING:** Never attempt to operate this transmitter without a crystal or VFO input since damage to the final amplifier can result.

8. Turn the ON-OFF switch to ON.
9. Allow a short period for warmup, then turn the TRANSMIT-STANDBY switch to TRANSMIT.
10. Close the key contacts and tune the OSCILLATOR control for about 2.5 ma grid current. (May vary from 2 to 5 ma, depending on the crystal and frequency of operation). Open the key contacts.
11. Set the Meter switch to PLATE.
12. Set the OPERATE-TUNE switch to OPERATE.
13. Close the key and tune the AMPLIFIER control for minimum plate current. Open the key contacts.
14. Again closing the key contacts, advance the LOADING control clockwise until plate current reaches 120 ma. Maintain resonance by tuning the AMPLIFIER control for minimum plate current while loading. Recheck and adjust the grid current to about 2.5 ma.

The transmitter is now fully loaded to an approximate 50 watt input level and is ready for operation.

If antenna relay operation is used note that when changing the TRANSMIT-STANDBY switch from TRANSMIT to STANDBY, the antenna relay changes the antenna from the Transmitter to the receiver, thus providing "single control" operation for your convenience.

If satisfactory operation is obtained, continue with the Final Assembly instructions. If difficulty was encountered, refer to the In Case Of Difficulty section of the manual.

#### OPERATING REMINDERS

- A. If operating frequency changes of more than a few kilocycles are desired, the final amplifier and driver stages may require retuning.
- B. Operation of the Transmitter without a crystal, a proper antenna, or dummy load will result in component failure.
- C. Operation of the transmitter with the final amplifier not tuned to resonance (minimum plate current) may ruin the final amplifier tube.
- D. Use caution and observe rules of safety in making all voltage and current measurements.
- E. Do not cover cabinet ventilation holes.

## FINAL ASSEMBLY

- ( ) Referring to Detail 7B, assemble the plug button and the threaded stud. Use a #6 lockwasher and 6-32 nut.
- ( ) Mount the large plain knob on the exposed stud and tighten the setscrew.
- ( ) Place the plug button into the crystal hole in the end of the cabinet.
- ( ) Refer to Detail 7C and install the four rubber feet in the bottom of the cabinet.
- ( ) Slide the chassis into the cabinet and secure it with seven #6 x 3/8" sheet metal screws in the holes in the rear of the cabinet.

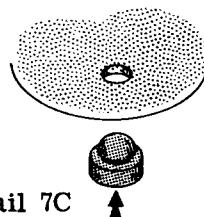

Detail 7C

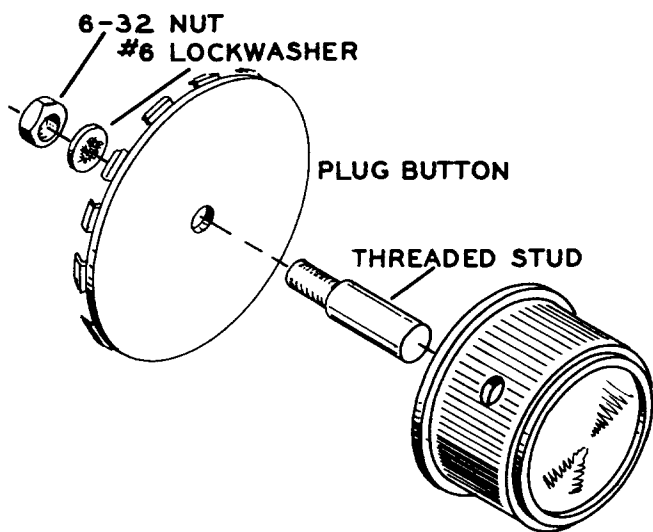

Detail 7B