

SPECIFICATIONS

Frequency Response:

AC VTVM.	10 cycles to 100 kc \pm 1 db.
Wattmeter.	10 cycles to 50 kc \pm 1 db.
I.M. Analyzer High Pass Filter.	2000 cps to 12000 cps.
I.M. Analyzer Low Pass Filter.	10 cps to 600 cps.

Sensitivity:

AC VTVM.	10 millivolts full scale maximum.
Wattmeter.15 milliwatts full scale maximum.
I.M. Analyzer.04 volts minimum high frequency signal required or .17 volts of LF and HF energy mixed 4:1.

Range:

AC VTVM.01, .03, .1, .3, 1, 3, 10, 30, 100, 300 volts RMS full scale.
DBM.	-40, -30, -20, -10, 0, +10, +20, +30, +40, +50 reads from -65 to +52 dbm.
Wattmeter.15 mw, 1.5 mw, 15 mw, 150 mw, 1.5 w, 15 w, 150 w full scale. Maximum continuous power 25 watts, intermittent power to 50 watts.
I.M. Analyzer.	1%, 3%, 10%, 30%, 100% full scale.

Input Impedance:

AC VTVM.	1 megohm or 4, 8, 16 or 600 Ω , switch selected.
I.M. Analyzer.	1 megohm or 4, 8, 16 or 600 Ω , switch selected.
Wattmeter.	4, 8, 16 or 600 Ω internal load, 10,000 Ω across external load.

Output Impedance:

Low and High Frequency Output.	3000 Ω (600 Ω when shunted with 750 Ω resistor).
--	---

Internal Generator Frequencies:

Low Frequency.	60 cycles.
High Frequency.	Approximately 6 kc.

Accuracy:

AC VTVM and Wattmeter.	Within 5% of full scale.
I.M. Analyzer.	Within 10% of full scale.

General:

Multipliers.	Precision type.
Meter.	4-1/2" streamlined case with 200 microampere movement.
Meter Rectifier.	Germanium diode bridge.
Tube Complement.	1 - 12AT7
	1 - 12AU7
	1 - 12AX7
	1 - 6C4
	1 - 6X4
Power Supply.	Transformer, full wave rectifier.
Power Requirements.	105-125 or 210-250 volts 50/60 cycles 20 watts.
Dimensions.	13" wide x 8-1/2" high x 7" deep.
Net Weight.	9 lbs.

The Heath Company reserves the right to discontinue instruments and to change specifications at any time without incurring any obligation to incorporate new features in instruments previously sold.

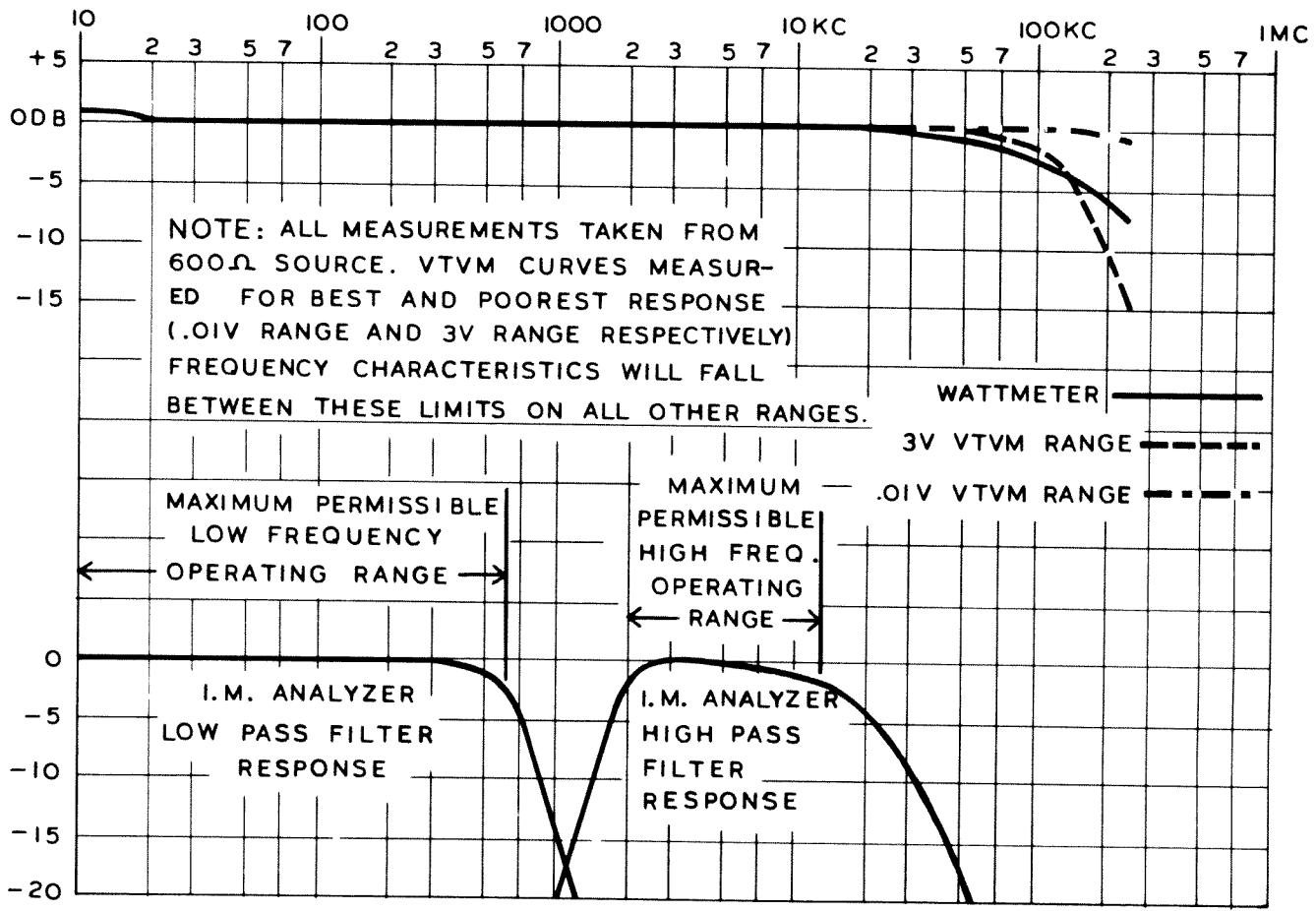

INTRODUCTION

The Heathkit Audio Analyzer Model IM-48 is a unique instrument, logically combining the functions of three important and useful audio test devices. Careful design allows a maximum in performance, flexibility and utility at the lowest possible cost. Care exercised in the construction of the instrument will be well rewarded with stable, trouble-free service.

Functions of the audio wattmeter, high sensitivity AC VTVM and intermodulation analyzer are all available in one instrument, which gives the operator a chance to make a very thorough analysis of audio equipment performance without the necessity of cluttering the workbench with various instruments and a sometimes bewildering number of test leads. Power output, noise,

gain, overload and intermodulation characteristics can be determined quickly and accurately using the two sets of test leads furnished and the flexible switching system incorporated in the analyzer. Noninductive load impedances of 4, 8, 16 and 600 Ω are built in and can be selected for any function by rotating the load selector switch to the desired resistance. A high impedance position is also provided for stage-to-stage and other high impedance circuit analyses.

Low and high frequencies are generated with the instrument and they can be taken out separately for testing purposes or mixed for I. M. measurements.

CIRCUIT DESCRIPTION

A. C. VOLTMETER: Three stages are employed to provide the amount of gain required to give a 10 millivolt full scale sensitivity. A 12AT7 tube is connected in a cascode type circuit which provides very high gain with relatively low noise level. Signal is applied to the control grid through the input selector switch and VTVM decade. The first half of the tube acts as a conventional voltage amplifier. Its plate load is made up of the plate resistance of the second half of the tube and the 22 K Ω resistor connected to B+. Voltage amplified by the first half of the tube is connected directly to the cathode of the second half, causing it to swing exactly the same amount. Gain in the second half of the tube is accomplished by effectively tying the grid to ground through a .05 μ fd condenser and isolating the grid from the cathode with a 390 K Ω resistor. Thus, the grid remains at a fixed potential while the cathode voltage is varied, causing the tube to act as though the grid potential were changing. Operation is much the same as a grounded grid amplifier. Loading for the second half of the 12AT7 is provided by a 22 K Ω resistor. Energy from the second half of the 12AT7 is coupled through a .05 μ fd condenser to the grid of the meter amplifier, one-half of a 12AU7 tube. Additional current amplification takes place in this tube and output energy is coupled to the meter rectifier through a 2 μ fd capacitor.

Two diodes are used in a half-wave bridge circuit to furnish DC current for the 200 microampere meter. Current returns to ground through the 4700 Ω resistors and the calibration control which complete the bridge. Since the 4700 Ω resistors return to the cathode of the VTVM input stage, inverse feedback is applied. Calibration is obtained by adjusting the calibration control which varies the cathode resistance. A change of resistance in the cathode of the input stage will change the amount of feedback and consequently, the gain.

Most crystal diodes have a nonlinear characteristic at low voltage levels causing nonlinearity or poor decading to be evident at the low end of the meter scale. Compensation for this characteristic is provided in case it should become evident. Detector nonlinearity is compensated for by making the meter movement nonlinear in the opposite direction. Another diode and a variable resistor are shunted across the meter allowing adjustment of meter linearity, thus providing excellent decading accuracy.

WATTMETER: Measurement of power requires the use of the AC VTVM previously described, and precision compensation networks to correct the voltage in relation to the power dissipated in the high wattage load resistors. Since the power

dissipated is related to the voltage out of the input network, the meter scale can be calibrated directly in watts, or power. External or internal loads of 4, 8, 16 or 600 Ω are selected by rotating the load selector switch to the desired position. The voltage correcting resistors are automatically connected in the correct sequence at the same time. Output from this network is connected to the VTVM decade or range switch. Power output can be read in dbm or watts on the red meter scales.

INTERMODULATION ANALYZER: Operating principles of an intermodulation analyzer are much the same as a broadcast radio. Mixed low and high frequencies are fed into the analyzer, which amplifies the high frequencies but rejects all low frequencies except those actually modulating the higher frequency. This modulated high frequency signal is set to a pre-determined level and is then detected or demodulated. The remaining signal will appear as a low frequency component and is passed through a low-pass filter to remove any residual HF component. Whatever signal is left is intermodulation and is indicated on the meter in percentage.

A 12AX7 tube is used as a high pass amplifier. Signal is fed through the input switch to the level control through a small capacitor. Output from the control goes through another small capacitor to the grid of the first half of the 12AX7 IM amplifier. Small values of capacity tend to attenuate low frequencies without seriously affecting high frequencies. Amplification of the high frequency takes place in the first half of the tube and output is taken from the plate through a capacitor to an LC type high-pass filter and to the grid of the second half of the tube. The signal is amplified further here and coupled to the grid of the detector through a condenser. Two resistors and a potentiometer make up the grid load for the detector and this network is used to calibrate the analyzer. A calibrated portion of the signal is taken out of the network and fed to the VTVM as a reference when setting the operating level for IM measurement.

One half of a 12AU7 is used as an infinite impedance or cathode follower detector for the high frequency signal amplified by the 12AX7. Signal is rectified or detected at the grid and any modulation that may be present will be evident at the cathode of the 12AU7. Some high frequency component will still be present, but this is bypassed

to ground in the low-pass filter which follows the cathode. Only low frequency signals are passed by the filter and output from this point is connected to the VTVM through the selector switch.

SWITCHING

LOAD SELECTOR: Load resistances of 4, 8, 16 and 600 Ω are selected as desired by rotating this switch. These resistances are available at all times and for all functions. A high Z (impedance) position is also provided for voltage and IM measurements in high impedance circuits. When external loads such as speakers are to be used, correct power measurements can still be made by switching to the proper impedance under external load. No power measurements can be made when the switch is in the HI Z position.

FUNCTION SELECTOR: All instrument functions are selected by the FUNCTION switch. In the first position, the input terminals are connected directly to the VTVM decade and the instrument operates as a 1 megohm input AC VTVM, unless the load selector is on one of the internal load positions.

The next function is power and the output of the wattmeter voltage-correcting divider is connected to the VTVM decade. At the same time, the input terminals are connected to the input of the dividing network. Impedance of the dividing network is 10 K Ω , so it must be disconnected for all other functions of the analyzer.

Measurement of low and high frequency test level is done in the LF-HF test position of the switch. The voltmeter will accurately indicate the true amount of signal output for each frequency separately and allows the proper ratio to be set at any desired output level. Signal from the output is connected directly to the VTVM decade through the selector switch in this position.

Initial adjustment for IM measurement is made with the switch in the SET LEVEL position. High frequency from the reference source at the grid of the 12AU7 detector is connected to the VTVM decade in this position. Proper level is obtained by placing the RANGE switch in the designated (.3 volt) position.

In the full clockwise position, the VTVM decade is connected to the output of the IM analyzer and low frequency intermodulation component is read directly on the meter.

RANGE SWITCH: VTVM decading is accomplished by use of the RANGE switch. This controls all of the functions of the AUDIO ANALYZER and the proper meter scales are marked on the front panel in terms of full scale readings. Precision 1% resistors are used and decading is arranged so that the attenuation is 10 db per step.

TEST SWITCH: Operating levels of the low and high frequencies can be checked individually by placing the switch in the appropriate position marked on the front panel. In the LF position, only the low frequency component will be available at the output terminals. Low frequency will also go to the meter when the FUNCTION switch is in the LF HF TEST position. When placed in the HF position, performance is the same except that only the high frequency will be available. This switch must be in the OPERATE position at all times except when the levels are being adjusted or when only one frequency is being used for testing purposes. All signal to the FUNCTION switch is shorted out in the OPERATE position to prevent high frequency cross-feed interference,

which can lead to misleading results. The low to high frequency ratio set by use of the switch will hold true when in the OPERATE position and for practically all settings of the OUTPUT control without the necessity of resetting the ratio.

POWER SUPPLY

The power supply employs a 6X4 full wave rectifier with well filtered DC output. Plate voltage for the rectifier and filament voltage for all tubes is furnished by the power transformer, as well as voltage for the low frequency signal source. Separate filtering systems are used for the high frequency oscillator and the analyzer to insure complete isolation. Resistors are used to drop the high AC rectifier plate voltage down to a level compatible with the high frequency oscillator and a condenser is connected between two of the resistors and ground to remove all harmonic content. This insures a pure 60 cycle waveform for low frequency test purposes.

The power transformer has a dual primary and may be wired for either 120 VAC or 240 VAC. As a safety feature, the chassis of the instrument is connected to the ground pin of the polarized plug furnished on the 3-wire line cord.

TESTING THE COMPLETED INSTRUMENT

If an ohmmeter is available, check the DC resistance between pin 7 of 6X4 socket E and ground. The resistance should be at least 20,000 Ω after one minute. If lower, carefully recheck wiring for an error. Give special attention to the connections around 6X4 socket E, the filter condenser and socket B.

Make sure that the line switch is off by rotating the I.M. ANALYZER INPUT control to its full counterclockwise position. Connect the line cord to the proper voltage. DO NOT CONNECT THIS INSTRUMENT TO A DC (DIRECT CURRENT) LINE. SERIOUS DAMAGE TO THE POWER TRANSFORMER WILL RESULT. Do not attempt to use this instrument on a 25 cycle source, for it will not operate and the transformer will be damaged.

Turn the instrument on by rotating the ANALYZER INPUT control clockwise until a click is heard. The filaments of all tubes and the pilot light should light. Now insert the 6X4 rectifier tube in socket E. Check the rectifier to see if the plates show color or the tube shows a bright violet glow. If so, turn the instrument off immedi-

ately and recheck the wiring for an error or short circuit. If any difficulty is experienced, the power should be disconnected and the steps outlined under "IN CASE OF DIFFICULTY" followed.

AC POWER LINE VOLTAGE MEASUREMENTS

CAUTION: Do NOT use the common (negative) lead of the VTVM when measuring power line voltages. This lead is already connected to the circuit ground and to the power line ground. If the common lead should contact the "hot" side of the power outlet, the power line will be short-circuited. Connect ONLY the meter probe, set on AC, to the power line. If there is no meter indication, connect the probe to the other side of the power line.

If you have occasion to measure a 240 volt, 3-wire, AC power line, you will get a meter indication at two of the three connections. The connection which produces no meter reading is the common side of the power line. Add together the voltages at the other two connections to determine the line voltage.

CALIBRATION

Before attempting calibration, turn VTVM CAL control Q to its extreme clockwise position and LINEARITY control R to its extreme counter-clockwise position. Place the LOADSELECTOR switch in the HI-Z position, the FUNCTION switch at VTVM and the RANGE switch to its full clockwise or 300 volt position.

Connect a test lead to the red IN terminal and to the AC line. Connection can be made to a plug or unused line cord or to terminal strip X3. If you use the line cord adapter (ungrounded) and a nonpolarized electric outlet, use two test leads. Connect the second lead between the black IN binding post and the other side of the electric outlet. CAUTION: The AC supply line is dangerous. Proceed with due care.

Adjust CALIBRATE control Q until the meter needle reads the line voltage AC supply on the 300 volt scale. If an accurate AC meter is at hand, the meter can be calibrated against it if there is reason to believe the line voltage is higher or lower than this.

(NOTE: Never connect the input across the AC supply line unless the LOAD SELECTOR switch is in the 600 Ω or HI-Z position. The 4, 8, and 16 Ω resistors will burn out if line voltage is applied with the switch placed in one of these positions.)

To adjust meter linearity, disconnect the input from the AC supply line. Rotate the FUNCTION switch to LFHF TEST and the TEST switch to LF TEST. Place the RANGE switch in the 3 or 10 volt position and adjust the LFHF GENERATOR OUTPUT control for a reading near or at full scale. Write the reading down for reference purposes and do not touch the output control again until adjustments are completed. Move the RANGE switch up one position in a clockwise direction and note the reading on the correct scale. It should be exactly the same voltage as written down. If not, return the RANGE switch to its original setting and with the meter needle near full scale, rotate the LINEARITY control R until the meter moves downscale slightly. Readjust control Q until the original reading is obtained once again and repeat the procedure. Adjustment is complete when good decading is obtained at all settings of the RANGE switch. In some cases, it may be necessary to disconnect the control entirely from the circuit in order to obtain good

linearity. This will be necessary only in cases where an exceptionally well balanced pair of diodes are used in the bridge rectifier.

No calibration of the Wattmeter is necessary since the AC VTVM is automatically corrected for power readings by use of precision resistors.

I.M. Analyzer calibration is a more complex operation and may be done in many different ways. Basically, a signal producing 10% IM is applied to the analyzer section and after the input control is adjusted to produce full scale reading on the 10% IM range, the IM CAL. control is set for full scale reading on the SET LEVEL positions of the FUNCTION and RANGE switches.

Before attempting to calibrate the I.M. Analyzer, the high and low pass filter chokes should be oriented for minimum hum pickup. Any hum picked up by the chokes will be reflected as erroneous IM readings and will also cause excessively high residual readings on lower IM% scales.

Adjustment is accomplished as follows: Set the LOAD switch to HI-Z, FUNCTION to VTVM and the RANGE switch to .3 volts to start. Remove the 12AX7 tube C from its socket. Set the LEVEL and OUTPUT controls to the extreme counter-clockwise positions. Connect a test lead to the "hot" input terminal and the opposite end to terminal strip M1. Move the RANGE switch to the right or left as necessary to obtain a satisfactory meter indication. Rotate choke N until a minimum reading is obtained. This completes the adjustment of the high pass filter choke.

Using the same control set up as before, connect the hot input lead to terminal strip H1. Connect another test lead to the grounded input terminal and the opposite end to H3. Rotate choke P for a minimum reading as before, adjusting the RANGE setting as necessary to maintain satisfactory indication. This completes the adjustment of the low pass filter choke.

It is unlikely that a complete null will be obtainable, but there need not be cause for concern since the small amount of pickup remaining after the chokes are tuned will not upset the accuracy of the I.M. Analyzer. Replace the 12AX7 tube C.

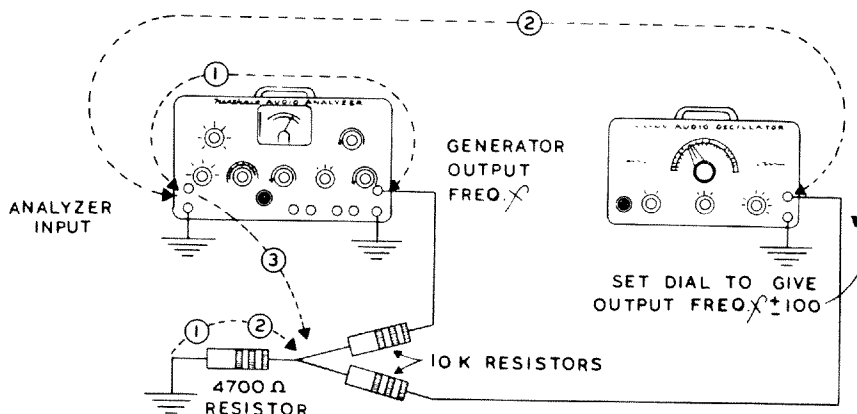

Figure 15

A satisfactory method of calibration, using a minimum of equipment requires an audio oscillator and a pair of resistors of approximately 10 K Ω each, furnished with the kit. The signal that will cause 10% IM may be generated by mixing the signal from the IM generator section with the signal from the audio oscillator in a voltage ratio of 10:1 and with a frequency difference of 60 to 100 cycles. An alternate calibrating method is also described in case no additional equipment is available.

Make up the calibrating resistor set by soldering the ends of two 10 K Ω and one 4.7 K Ω resistors together as shown in Figure 15. Place the TEST switch in the HF TEST position to remove the 60 cycle signal from the generator output, leaving only the 6000 cycle signal.

Study Figure 15. Note that some connections are designated by the use of solid lines and some are represented with broken lines. Solid line connections are kept throughout the complete calibrating procedure which follows, while broken line connections are kept only for the part of the calibration procedure in which they are specifically referred to by number.

A. Make the solid line connections as follows: Connect one of the matched resistors to the hot output terminal and through the 4.7 K Ω resistor to ground. Connect the other 10 K Ω resistor to the audio oscillator output terminal and through the same 4.7 K Ω resistor to ground.

B. Set the FUNCTION switch to VTVM, LOAD switch to HI-Z and the ANALYZER INPUT and GENERATOR OUTPUT controls to minimum or extreme counterclockwise positions. Set the RANGE switch to 10 volts and connect the input terminal of the Analyzer to the junction of the three resistors, as indicated by dotted line #3 in the sketch.

Adjust the audio oscillator to zero beat with the Analyzer internal generator output. To obtain this beat, set the HIGH FREQUENCY LEVEL and GENERATOR OUTPUT controls on the Analyzer to maximum. Also set the output from the audio oscillator to maximum. Turning the audio oscillator through the 6000 cycle signal from the Analyzer will cause the meter pointer to swing with the beat note.

C. After zero beat has been obtained, set the audio oscillator to a new frequency about 60-100 cycles higher or lower. Remove connection #3. Make the two connections #1 as follows: Short the 4.7 K Ω resistor and connect the input terminal to the Analyzer generator output. Adjust the HIGH FREQUENCY LEVEL and GENERATOR OUTPUT controls to give a suitable reading (somewhere near the maximum obtainable) on the 30 volt range.

D. Remove connections #1 and make connections #2, shifting the input terminal lead from the output of the Analyzer generator to the output of the audio oscillator. Keep the short across the 4.7 K Ω resistor.

Adjust the output control on the audio oscillator to give the same meter deflection as obtained in the paragraph above but on the 3 volt range. Thus, a voltage ratio of 30:3 or 10:1 is established.

- E. Remove all connections #2 and make connection #3. This removes the short across the 4.7 K Ω resistor and connects the input of the analyzer to the junction of the three resistors. Making these connections applies the desired mixed signal to the analyzer and will result in a carrier with 10% modulation at the detector in the analyzer. Set the RANGE switch to 10% IM and the FUNCTION switch to % IM. Adjust the I.M. ANALYZER INPUT control for full scale meter deflection. Next, set the FUNCTION switch to SET LEVEL and the RANGE switch to the indicated SET LEVEL position (3% IM). Adjust the IM CALIBRATE control Z for full scale deflection of the meter.

If an audio oscillator is not available, practical calibration of the IM analyzer section can be accomplished by modulating the internal high frequency oscillator with a 60 cycle waveform. To accomplish this, set up the instrument as follows: Set the TEST switch to HF TEST, FUNCTION switch to % IM, RANGE switch to

10% IM and the LOAD switch to HI-Z. The indicator line on the HIGH FREQUENCY LEVEL and LF HF GENERATOR OUTPUT control knobs should be turned straight up, assuming that they have been properly indexed when installed. Adjustment of the output controls is not critical so approximate positions are adequate. Connect a test lead between the hot output terminal and the hot input terminal of the analyzer. Connect another test lead from either of the LOW FREQ. binding posts to the cathode of the high frequency oscillator, pin 7 of socket D. This applies 60 cycle energy to the cathode of the oscillator, modulating it approximately 6.4%. Adjust the I.M. ANALYZER INPUT control until the meter reads 6.4% on the 10% scale. Next, set the FUNCTION switch to SET LEVEL and the RANGE switch to the SET LEVEL or 3% IM position and adjust IM CALIBRATE control Z for a full scale reading at the SET LEVEL point. Remember that using this procedure may result in an error of approximately 10% in indicated reading. The first calibrating procedure is recommended when high accuracy is required.

This completes the calibration of your Audio Analyzer. Install the instrument in the cabinet, securing with self-tapping screws through the holes in the back.

OPERATION OF THE AUDIO ANALYZER

A review of the circuit description in the front of the manual might be helpful. Operation of all controls and circuits is described in detail and a full understanding of instrument functions will greatly increase its usefulness in the audio lab. Some applications are outlined here which describe the basic operations and some other applications are suggested with the hope that they will be a guide to other advanced uses of the analyzer. Thorough familiarity with the flexible switching

system incorporated will enable the operator to find many other uses for the unit, making it a very valuable and often used piece of equipment.

CAUTION: The circuit ground and the case of this instrument are both connected to the power line ground through the green wire of the line cord. Always connect the ground test lead of this device to the chassis, or ground, of the circuit being tested or measured.

CAUTION: The LOAD selector switch should never be rotated when energy is applied to the analyzer input. If it becomes necessary to change impedance settings, the input to the amplifier under test should be turned down, or the amplifier turned off. Damage to the meter needle due to violent slamming against the stops will be avoided if this precaution is observed.

Highly accurate monitoring of output level for recording or program feed purposes can be accomplished by connecting the analyzer across the amplifier output leads and setting the LOAD selector switch to the proper impedance under EXT. load. Circuit ballistics are such that the instrument makes an excellent db meter.

Set up of cross-over networks in multiple speaker systems is easy using the power scales of the Analyzer. A variable frequency audio oscillator should be connected to the audio amplifier input, and the analyzer to the output of one of the cross-over network sections. All remaining sections should be loaded with speakers or resistors. Set the LOAD switch to the appropriate network impedance under INT. load and run a response on the network, noting the output level. Next, the analyzer is connected across another section, returning the original load to the section previously tested and the procedure repeated. A very useful picture of network performance can be obtained in this manner.

If complex waveforms are to be measured, the information under USING THE AC VTVM should be observed.

Occasionally it may be necessary to measure power at levels higher than 50 watts, especially when public address systems are being tested or serviced. Power measurements up to 100 watts continuous or 200 watts intermittent can be made by dissipating a major portion of the power externally. Four resistors of the same value as the amplifier output impedance are required, one of which is one of the internal resistors in the Analyzer. The power ratings of the other three resistors should be at least 25 watts and non-inductive types are recommended. Two of the resistors should be connected in series and the other external resistor connected in series with the internal load resistor in the analyzer. The two combinations should be connected in parallel as shown in Figure 16. Set the LOAD selector switch to the same value of resistance as the external resistors under INT. LOAD. Read the power on

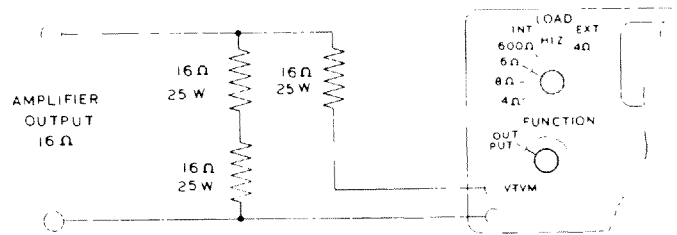

Figure 16

the appropriate meter scale and multiply the reading by 4 to obtain the true power output reading. One quarter of the total power will be dissipated in each resistor, so the readings will be just as accurate as if the amplifier were fed directly into the analyzer.

Example: The amplifier has a $16\ \Omega$ output. Three $16\ \Omega$ 25 watt resistors will be connected as shown and the LOAD switch set to $16\ \Omega$ under INT. LOAD. Turn on the amplifier and note the meter reading. Assuming that the meter reads 20 watts, the amplifier output will be 4×20 watts, or 80 watts. If the amplifier has a 4 or $8\ \Omega$ output, 4 or $8\ \Omega$ resistors will be used and the LOAD switch set to the same value as the external resistors and the amplifier impedance.

USING THE INTERMODULATION ANALYZER

The IM analyzer section of the Audio Analyzer is designed to function in accordance with the standard test conditions as formulated by the Society of Motion Picture Engineers (SMPE). Flexibility of the instrument permits a variety of other sets of conditions to be used.

Standard conditions require a signal output from the generator to consist of a low frequency signal and a high frequency signal, in a ratio of 4:1 and this is obtained as follows:

Place the FUNCTION switch in the LFHF TEST position, the RANGE switch in a position indicating a voltage approximating that to be used and the TEST switch to LF TEST. Advance the GENERATOR OUTPUT control to give the desired amount of voltage. Next, switch TEST to HF TEST and advance the HIGH FREQUENCY LEVEL control to give a reading just $1/4$ of the reading obtained on LF TEST. Return the TEST switch to OPERATE, as the proper ratio is now set.

Example: LF TEST is set to 2 volts on the 3 volt range. HF TEST will be set to .5 volts on the same range.

Other voltages can be set in the same ratio, using whatever is needed to drive the amplifier under test to the desired output. Adjustment of output voltage can be done over a fairly wide range, using the LF HF GENERATOR OUTPUT control without changing the ratio substantially as long as the HIGH FREQUENCY LEVEL control is not touched.

NOTE: Be sure that you only connect to one channel at a time when making measurements on stereo amplifiers. Use care, and do not operate amplifiers without leads. Also, if there is a speaker reversal switch, be sure it is in the "Normal" position.

Connect the red (upper) output terminal of the analyzer to the amplifier input. If the output control cannot be adjusted to the desired input level of the equipment under test, additional attenuation may be inserted. Note that the generator output impedance is 3000 Ω . Shunting the output terminals with a 750 Ω resistor will result in a net output impedance of 600 Ω .

Connect the output terminals of the amplifier under test to the Analyzer input and set the LOAD switch to the proper load impedance (4, 8, 16 or 600 Ω if used at the output of an amplifier, HI-Z if used for stage by stage analysis). The output level may be determined by switching to OUTPUT or VTVM on the FUNCTION switch. Next, place the FUNCTION switch in the SET LEVEL position and the RANGE switch to the point indicated by the line between the two switches (3% IM). Advance the I.M. ANALYZER INPUT control to the "set level" mark on the meter. Place the RANGE switch in the 30% IM position and rotate the FUNCTION switch to %IM. Read the distortion figure on the appropriate meter scale (0-10 scale for 1, 10 and 100% and 0-3 scale for 3 or 30%). Move the RANGE switch to the right or left as needed to give a satisfactory indication.

Note that the frequency response of the equipment under test must be reasonably flat between the limits of the low and high frequency signals used, to prevent misleading indications. Also notice that the equipment under test may range all the way from a single component part to a complex device such as a speech amplifier-modulator-transmitter-monitor chain, or tape recorder-playback amplifier system.

Phonograph pickups and preamplifiers may be checked by using standard IM test records, provided that the signal frequencies and level ratios are within the limitations of the analyzer section as described under circuit specifications.

NOTE: When making intermodulation distortion measurements, do not use any accessory instruments that have an earth ground connection (3-wire power plug). Use a line cord adapter on the polarized plug. An earth ground connection can cause ground loop currents that will make your distortion readings invalid. This applies particularly to solid state amplifiers and all amplifiers that have current feedback through the speaker to the "common" output terminal.

THEORY OF INTERMODULATION

For any device involving input and output signals, a plot of the instantaneous input and output signals will give an input-output characteristic. For exact reproduction in electronic amplifiers, it is readily evident that a linear characteristic is necessary. The inherent curvature of tube characteristics and non-linearity of other circuit elements, such as transformers, make a linear I-O characteristic not readily obtainable.

Although generally a very small portion of the characteristic may be considered substantially linear, at increased signal input levels additional curvature gives cause to a condition known as overload.

Curvature of the I-O characteristic gives rise to distortion which is known as "non-linear distortion." There are three methods presently used for determining this non-linear distortion: the harmonic distortion test, the intermodulation test by the SMPE method and the intermodulation test by the CCIF method.

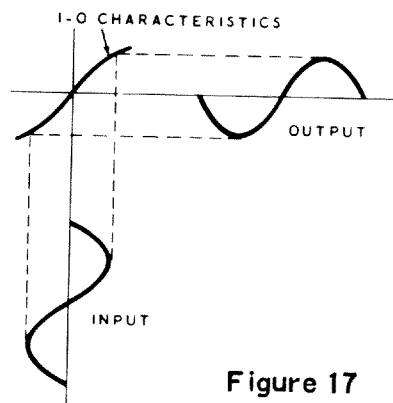

Figure 17

The harmonic distortion test measures the amplitude of the individual or combined harmonics generated by the equipment under test, when a pure sine wave signal is applied. The result is expressed as a percentage of the pure signal.

The SMPE method measures the interaction of two pure sine wave signals of different frequencies when passed through the equipment under that test. This method uses standard test conditions as prescribed by the SMPE and the result is expressed as a modulation percentage of one signal upon the other.

The CCIF method uses a similar principle under a different set of standard test conditions.

While these three methods all express their findings in "percent distortion," there is no evidence to substantiate one method better or more complete than another, nor is there any fixed relationship between the percentage figures obtained by the three methods.

It should be further pointed out that it is impossible to predict from a harmonic distortion measurement what percentage of intermodulation distortion may be present in a system. Conversely, a system relatively free of intermodulation distortion might conceivably generate moderate amounts of harmonic distortion at specific frequencies.

Essentially, two-signal operation of a device with a non-linear I-O characteristic results in modulation of one signal by the other signal. This modulation produces sidebands adjacent to the signal acting as carrier.

To illustrate, assuming input frequencies of 60 and 3000 cycles, non-linear operation would cause 60 cycle modulation of the 3000 cycle signal, resulting primarily in an output containing the following frequencies:

$$\begin{array}{l} 60 \text{ cycles} \quad 3000 + 60 = 3060 \text{ cycles} \\ 3000 \text{ cycles} \quad 3000 - 60 = 2940 \text{ cycles} \end{array}$$

The inherent harmonic distortion caused by non-linear operation results in additional frequencies. Second harmonic distortion, for instance, adds the following frequencies:

$$\begin{array}{l} 2 \times 60 = 120 \text{ cycles} \\ 2 \times 3000 = 6000 \text{ cycles} \\ 3000 + 2 \times 60 = 3120 \text{ cycles} \\ 3000 - 2 \times 60 = 2880 \text{ cycles} \\ 2 \times 3000 + 60 = 6060 \text{ cycles} \\ 2 \times 3000 - 60 = 5940 \text{ cycles} \\ 2 \times 3000 + 2 \times 60 = 6120 \text{ cycles} \\ 2 \times 3000 - 2 \times 60 = 5880 \text{ cycles} \end{array}$$

The harmonic distortion of a single frequency signal results in addition of harmonics to the original signal. In speech and music, this would result in a change in timbre or tone color.

The intermodulation distortion of multi-frequency signals results in addition of harmonically unrelated frequencies. As these additional frequencies are clustered around the original frequencies, they tend to blur the original signal. The location in the middle and upper region of the audible spectrum, at which the sensitivity of the human ear is high, makes these additional frequencies distinctly noticeable although their relative amplitude may be small.

The more seriously audible effects of IM distortion make its measurement highly urgent in equipment intended for use in conjunction with audible reproduction of multi-frequency signals.

USE OF THE VOLTMETER FOR MULTIPLE FREQUENCY MEASUREMENTS

It should be noted that the two-frequency signal used for IM testing alters the generally accepted relationship between the RMS, average and peak values, which only hold true for a single sine wave. In the case of a single frequency signal, the meter will indicate the RMS value, while responding to the average value of the signal. In the case of the complex waveform of a two-frequency signal, the meter will respond to the average value of that signal, but the altered relationship between average and RMS values will cause a discrepancy in the indication. Such discrepancies will generally not be importantly large.

VOLTAGE CHART

All readings are taken with an 11 megohm vacuum tube voltmeter. All readings are DC voltages measured to chassis, unless otherwise specified. Variations up to 20% are normal and do not indicate trouble in most cases.

SOCKET TUBE TYPE	Pin 1	Pin 2	Pin 3	Pin 4	Pin 5	Pin 6	Pin 7	Pin 8	Pin 9
A 12AT7	180	65	100	Fil.	Fil.	100	NS	NS	Fil.
B 12AU7	300	NS	20	Fil.	Fil.	35	NS	0	Fil.
C 12AX7	250	NS	2	Fil.	Fil.	130	NS	1.7	Fil.
D 6C4	210	NC	Fil.	Fil.	NC	-60	11		
E 6X4	250-300 VAC	*	Fil.	Fil.	*	250-300 VAC	325		
FILTER CONDENSER		•	325	■	300	▲	240	—	230

NC - no connection to this contact.

NS - not significant.

*Voltage between pins 2 and 5: Line voltage.

Fil. - voltage between two terminals so marked approximately 6.3 volts AC.

Readings were taken under the following conditions: LOAD at HI-Z, FUNCTION at VTVM, RANGE at 300 V, TEST at OPERATE and LEVEL and OUTPUT CONTROLS fully counterclockwise.

Carefully recheck the color codes on resistors, condensers and transformer leads. If there is a question concerning the color of a transformer lead, scraping the insulation lightly with a knife may help to identify the color quickly.

Some common troubles are listed below along with troubleshooting procedures which may be helpful in locating the source of difficulty.

INSTRUMENT COMPLETELY INOPERATIVE

If the instrument fails to operate, check the tubes to see if the filaments are lit. If there is no evidence of heating, measure across the end of the AC line inside the chassis. Lack of AC energy at this point indicates either an open line cord or imperfect connection at the outlet. The AC cord can be checked quickly with an ohmmeter. When voltage is obtained at this point, the voltmeter should be moved to connect across the black and black-red power transformer primary leads. No voltage at this point when the power switch is turned on indicates a defective switch on the back of the INPUT control or a wiring error.

Should voltage be present at all points in the AC line circuit, a short in the filament or rectifier plate or cathode circuits can be suspected. Careful visual inspection will usually reveal the source of trouble. If not, all tubes should be removed and the power transformer disconnected from the circuit. Ohmmeter checks for wiring shorts can then be made and the power transformer checked for open windings.

AC VTVM INOPERATIVE

If the VTVM will not operate, it will be impossible to get any indication from the other functions of the analyzer. Therefore, the VTVM should always be checked first when the entire instrument fails to operate properly.

Check the FUNCTION and RANGE switches against the pictorials and schematic to make sure the switches are constructed properly and all connections to these switches for proper order and short circuits. Special attention should be given to the shielded leads, for a practically invisible piece of braid can short against the center conductor, completely shorting out all signal. Once sure that the switching is all right, checks should be made at pins 1 and 6 of socket A, and pin 6 of B to see if proper B+ is present. Checks should also be made at pins 7 of A and 7 of B to make sure B+ is not present. Any positive potential at these points indicates a leaky coupling condenser. Calibrate control Q should be measured with an ohmmeter to make sure continuity exists. Check the 12AT7 and 12AU7 tubes, giving special attention to heater-to-cathode leakage in the 12AT7.

Consistent full scale reading of the meter indicates that the VTVM is oscillating. Careful redress of leads and components will usually clear this up. Rotate control Q rapidly back and forth a few times to insure good contact and at the same time, make sure too much feedback does not exist. This is done by rotating the control to its full counterclockwise position before attempting to calibrate the VTVM. Also check the 2 μ fd coupling condenser for excessive leakage.

Downscale readings on the meter indicate that the crystal diodes have been installed backwards. Proper readings will be obtained by reversing the connections to the meter, or reversing all of the diodes, whichever is more convenient.

If there is a reason to suspect the meter or meter rectifiers, they can be checked as follows:

Disconnect one end of each crystal diode from the circuit and connect an ohmmeter across each one in turn and note the reading. Next, reverse the connections to the diodes and note the reading again. The back to front ratio should be at least 50:1 or the diode is defective and should be replaced. To check the meter movement, connect a 10,000 Ω resistor to either meter terminal, disconnecting one of the circuit leads at the same time. Connect a single 1.5 volt flashlight battery to one side of the meter and the resistor, observing polarity. No deflection of the meter needle indicates an open or defective movement. DO NOT connect an ohmmeter or battery directly across the meter terminals, since this will burn the movement out almost immediately.

OUTPUT METER INOPERATIVE

If the VTVM will operate but the instrument will not measure power output, the trouble must lie in the switching. Attention should be given to the LOAD and FUNCTION switches to make sure the switches and connections are correct. All precision resistors on the LOAD switch should be checked out, as well as the 1258.2 K Ω unit connecting to the FUNCTION switch. Inspect terminal strip K for short circuits as well as the shielded cables involved.

IM ANALYZER INOPERATIVE

A high-gain hi-pass amplifier is used in the IM section and any flaw in the amplifier will cause improper performance. Check the 12AX7 tube and if possible, substitute another for comparison purposes. Inspect all terminal strips, shielded cables and tube socket pins for shorts between terminals and to ground. Make sure the proper filter choke is installed at the correct location and connected properly. Check chokes for continuity.

Sometimes a signal tracing technique can be used to isolate the trouble to one stage. First, connect a test lead between the output of the analyzer and the input and set a 4:1 ratio of the internal generators just as if actual IM measurement were to be made. Set the FUNCTION switch to SET LEVEL and the RANGE switch to the appropriate position. Make sure

the TEST switch is in the OPERATE position. Advance the I.M. ANALYZER INPUT control slowly and note whether or not any reading is evident. If a full scale reading can be obtained, the trouble lies in the 12AU7 stage and after. If not, something in the 12AX7 stage is at fault.

Assuming the 12AX7 stage is imperfect, a simple test can be made as follows: Switch FUNCTION to VTVM, LOAD to HI-Z and advance the INPUT control about 1/4 or 1/2 open. Connect one test lead between the output terminal and terminal strip K3. Connect another test lead to the input and the other end to socket C2. An AC reading should be evident. If necessary, rotate the INPUT, OUTPUT and RANGE controls for a satisfactory reading. Use low levels to avoid overloading. Next, connect the input lead to C1 and observe the reading. It should be considerably higher than at C2. (CAUTION: High voltages are present in these circuits. Proceed with due care.) If everything is all right at this point, connect the input lead to C7. The reading should be somewhat lower than at C1. The next test point is at C6. Look for a higher reading once again. Next is B2 which should be approximately the same as C6. Readings up to this point indicate that the high gain amplifier is operating properly. Final check is made by connecting the test input lead to terminal strip H4. Signal should be present, but at considerably lower amplitude. No signal indicates a shorted cable or terminal strip, or possibly a defect at control Z.

Proper indications to this point would seem to indicate that trouble lies in the low-pass filter. To test this, place the TEST switch in the LF TEST position and connect the output lead to B2. Other control settings will remain as before. Connect the input test lead to B2 and note the level. Next, connect the input lead to B3. The level should be slightly lower than at B2. The next lower readings being evident at each terminal in order. A sudden drop in level at any point indicates a possible short circuit on the associated terminal strip or some defect around the FUNCTION switch.

INTERNAL GENERATORS INOPERATIVE OR DEFECTIVE

Lack of 60 cycle energy at the output can most likely be traced to terminal strip L and its associated components. Make sure that all components are all right and that proper connections have been made between L and socket E and L and the TEST switch. Check the LOW FREQ. binding posts for short circuits, making sure the shoulder insulating washers are properly centered. Inspect the TEST switch and associated connections carefully.

No high frequency output indicates a defect around the 6C4 tube, socket D, terminal strip J, the HIGH FREQUENCY LEVEL control and its associated shielded wire, the TEST switch or the HIGH FREQ. binding posts. Oscillation can be checked for by setting up the analyzer as a HI-Z VTVM as before and connecting the input test lead to J4. Lack of AC voltage indicates that there is no oscillation and checks of the tube, oscillator coil (continuity) and components are in order. If energy is present, check all other components mentioned above.

The 6000 cycle frequency specified for the high frequency oscillator is not necessarily exact, since variations in components will cause corresponding variations in frequency. While it is likely that the frequency can be adjusted by changing condensers etc., this procedure is not necessary. Frequency variations will in no way alter measurement accuracy as long as the frequency remains within the limits of the high pass filter.

The OUTPUT control is common to both generators and can be suspected if there is no output from either generator at any time, regardless of the position of the TEST switch. Insulation on the output terminals should also be checked, for a short at this point will completely disable the output.

Refer to the Kit Builders Guide for service and Warranty information.

In the full clockwise position, the VTVM decade is connected to the output of the IM analyzer and low frequency intermodulation component is read directly on the meter.

RANGE SWITCH: VTVM decading is accomplished by use of the RANGE switch. This controls all of the functions of the AUDIO ANALYZER and the proper meter scales are marked on the front panel in terms of full scale readings. Precision 1% resistors are used and decading is arranged so that the attenuation is 10 db per step.

TEST SWITCH: Operating levels of the low and high frequencies can be checked individually by placing the switch in the appropriate position marked on the front panel. In the LF position, only the low frequency component will be available at the output terminals. Low frequency will also go to the meter when the FUNCTION switch is in the LF HF TEST position. When placed in the HF position, performance is the same except that only the high frequency will be available. This switch must be in the OPERATE position at all times except when the levels are being adjusted or when only one frequency is being used for testing purposes. All signal to the FUNCTION switch is shorted out in the OPERATE position to prevent high frequency cross-feed interference,

which can lead to misleading results. The low to high frequency ratio set by use of the switch will hold true when in the OPERATE position and for practically all settings of the OUTPUT control without the necessity of resetting the ratio.

POWER SUPPLY

The power supply employs a 6X4 full wave rectifier with well filtered DC output. Plate voltage for the rectifier and filament voltage for all tubes is furnished by the power transformer, as well as voltage for the low frequency signal source. Separate filtering systems are used for the high frequency oscillator and the analyzer to insure complete isolation. Resistors are used to drop the high AC rectifier plate voltage down to a level compatible with the high frequency oscillator and a condenser is connected between two of the resistors and ground to remove all harmonic content. This insures a pure 60 cycle waveform for low frequency test purposes.

The power transformer has a dual primary and may be wired for either 120 VAC or 240 VAC. As a safety feature, the chassis of the instrument is connected to the ground pin of the polarized plug furnished on the 3-wire line cord.

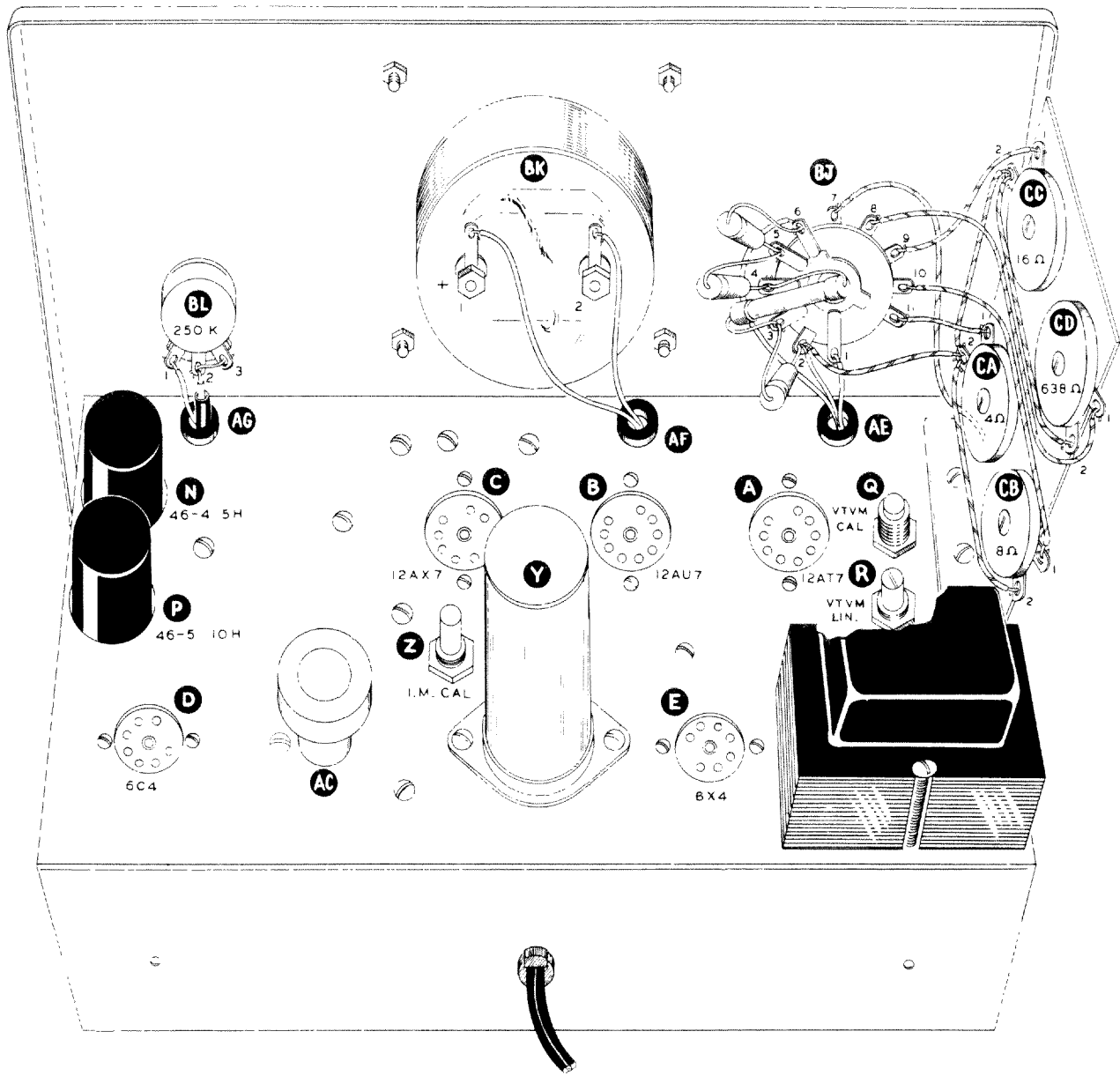

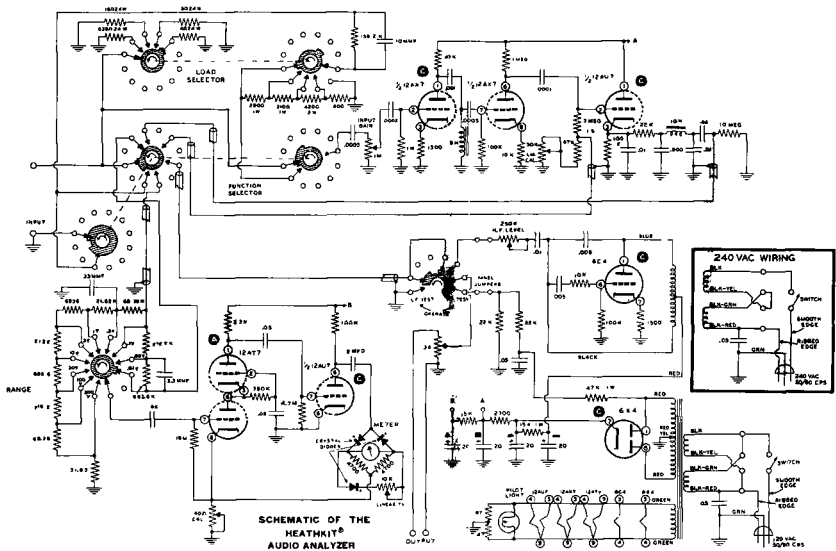

**SCHEMATIC OF THE
HEATHKIT®
AUDIO ANALYZER
MODEL IM-48**

