

Heathkit[®] Manual

for the

SIGNAL TRACER

Model IT-5283

595-1960-03



HEATH COMPANY
BENTON HARBOR, MICHIGAN 49022

Copyright © 1977
Heath Company
All Rights Reserved
Printed in the United States of America

OPERATION

The Signal Tracer is one of the simplest, most effective instruments for rapid troubleshooting in radio and TV circuits. It is the "untuned" type which makes it simple to operate and also means that you will have to change control settings less often.

This instrument has a number of useful applications to help you quickly locate and diagnose the trouble in the circuit under test. You should become familiar with the different phases of the instrument's operation so that you will get the maximum benefit from it.

The procedures outlined in this section of the Manual are of a general nature, and do not represent the limits of its applications. As you use the instrument, you will develop your own procedures and applications.

NOTE: If you use batteries to power your Signal Tracer, do not turn the level control any higher than necessary since the higher the volume is set, the faster the batteries will discharge.

RF SIGNAL TRACING

When you use the Signal Tracer for RF signal tracing, turn the probe switch to the (→+) position, and the FUNCTION switch to the SIGNAL TRACER position. Adjust the LEVEL control no higher than necessary.

NOTE: At near maximum settings of the LEVEL control, a certain amount of hum is present. This is due to the high sensitivity of the Signal Tracer which permits it to pick up stray AC fields.

To illustrate the use of the instrument, a typical radio schematic is presented in Pictorial 8-1 so the test points may be clearly pointed out. Assume that the receiver under test has a specific problem of low volume. Since the radio is not completely dead, it can be turned on and tuned to a station. The volume control should be turned down so the radio's output does not interfere with the Signal Tracer's output. The black test lead of the probe should be clipped to the chassis or ground circuit of the radio. If the radio is tuned to a

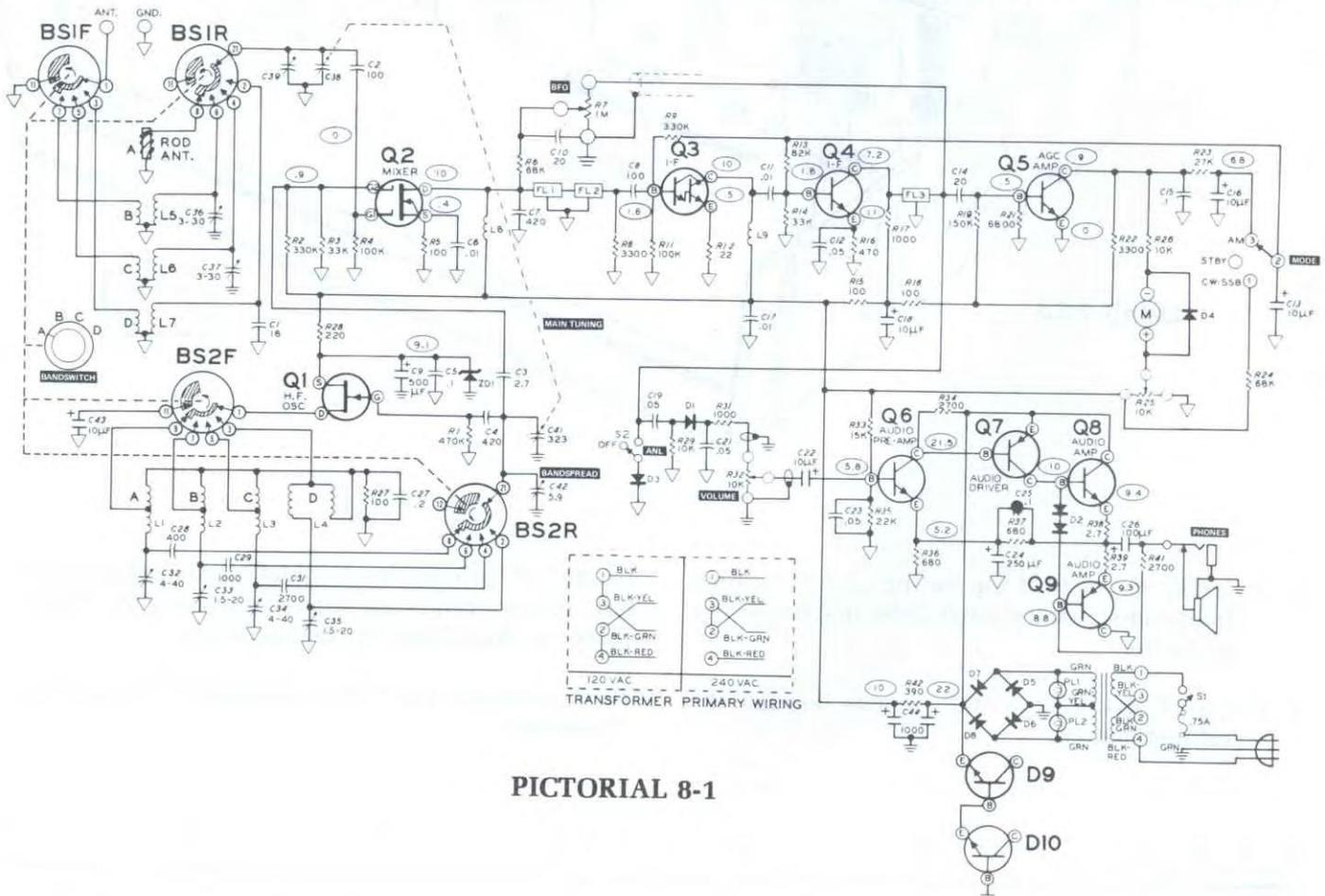

PICTORIAL 8-1

strong station, and the probe is connected, a signal should be present at the rod antenna, the tuning capacitor, and G1 of FET Q2. On some radios, the hum overrides the signal, which makes it necessary to move the probe to the 1st IF stage (base of transistor Q3), in order to check the operation of the first stage.

You can trace the path of the signal through the succeeding IF stages to the detector. During these tests, you can estimate the gain per stage. The amount of gain that can be expected in a circuit can best be determined by reference to manufacturer's specifications or by previous experience in making similar tests.

In some cases the RF probe causes a slight detuning effect when you apply it to tuned circuits. In these cases, advance the test probe to the next test point. If a good signal is present, it is reasonable to assume that the preceding stage is functioning properly.

You can use the same general procedure in checking RF and IF stages in TV and FM circuits. Since the actual signal is most important, the Signal Tracer will detect the presence or absence of the signal regardless of the type of circuit involved.

AUDIO SIGNAL TRACING

After the signal has gone through the detector (diode D1) in the radio, the RF probe is not required. Turn the probe switch to the DC position. Here again, the same general conditions apply as described previously. After the detector stage, you can trace the signal through the audio stages (transistors Q6, Q7, Q8, and Q9), to the speaker. These tests can be made quickly and easily and any circuit fault will be indicated by a loss of gain or signal in succeeding stages. You can also spot intermittent or faulty volume controls or coupling capacitors. When you use the Signal Tracer, keep in mind that it will detect the presence as well as the absence of a signal. For example, it is common practice to use a high capacity by-pass capacitor in the audio output circuit. If the capacitor is open, there

will be a definite indication of a signal at the by-pass capacitor, whereas a good capacitor will pass the signal to ground in the desired manner.

As you trace the signal through the audio circuit, the signal will be very high, so reduce the LEVEL control on the Signal Tracer.

TEST SPEAKER

In service work, it is sometimes necessary to take the chassis of a radio or TV to the repair shop to complete the repair work. In many instances, the speaker is separate, and may be rather inaccessible. The circuit may specify a permanent magnet type speaker. If so, you can substitute the Signal Tracer's speaker in these cases. When the FUNCTION switch is in the OFF/SPKR SUB position, the speaker in the Signal Tracer is disconnected from the tracer circuitry and connected to the front panel jacks. Thus, the radio or TV speaker wires are connected directly to these jacks. This feature eliminates the need to remove and reinstall the speaker on every service job.

AUDIO SYSTEMS

Quite frequently, service technicians may service automatic record changers or phono mechanisms. When mechanical repairs or adjustments are made on the changer mechanism, they may want to check the output of the phono cartridge. By connecting the INPUT of the Signal Tracer to the output of the record changer, the changer's output can be heard in the speaker of the Signal Tracer. Any irregularity in mechanical operation, such as turntable wow or thump, or any objectionable noise that could be transmitted through the phono cartridge and reproduced as an undesirable condition, will be heard in the Signal Tracer's speaker.

You can also use the same procedure in checking microphones and musical instrument pickups. Generally the Signal Tracer will check any equipment which requires an audio system.

LOGIC TRACER

When you place the probe switch in the DC position and the FUNCTION switch in the AUDIBLE V/ Ω position, an "audible voltmeter" is created. This circuit could also be called an "audible ohmmeter," since it will respond to either changing voltage or resistance. When you touch the probe tip to the black test lead alligator clip (ground), an audible tone is produced in the speaker. As you increase the voltage or decrease the resistance, the frequency of the tone increases. As you decrease the voltage or increase the resistance, the frequency of the tone decreases. The Signal Tracer's circuitry will respond to voltages from approximately -3 volts to $+20$ volts DC, and to resistance from 0Ω to $5 \text{ M}\Omega$.

When you signal trace a logic circuit, apply a slow square wave of 4 or 5 Hz. NOTE: Apply the probe directly to the generator's output to become familiar with the tone produced. Move to each succeeding stage throughout the logic circuitry until you no longer hear the familiar pattern, or until you detect a change in the frequency of the tone. While you become familiar with the Logic Tracer, frequent references to ground and the supply voltage will help you remember what to listen for with regard to "logic 1" and "logic 0" tones.

IN CASE OF DIFFICULTY

This part of the Manual provides you with information that will help you locate and correct difficulties which may occur in your Signal Tracer. This information is divided into two sections. The first section, "General," contains suggestions of a general nature in the following areas:

- Visual check and inspection.
- Precautions to observe when bench testing.

The second section is a "Troubleshooting Chart" which contains a series of "Conditions" and "Possible Causes." Start your troubleshooting procedure by first reading the following "General" section. Then proceed to the appropriate "Condition" and "Possible Cause."

GENERAL

Visual Checks

1. About 90% of the kits that are returned for repair do not function properly due to poor soldering. Therefore, you can eliminate many troubles by a careful inspection of connections to make sure they are soldered as described in the "Soldering" section of the "Assembly Notes." Reheat any doubtful connections and be sure all the wires are soldered at places where several wires are connected. Check carefully for solder bridges between circuit board foils.

2. Check to be sure that all transistors are in their proper locations, and are installed correctly.
3. Check the value of each part. Be sure that the proper part has been wired into the circuit, as shown in the Pictorial diagrams and as called out in the wiring instructions. It would be easy, for example, to install a 2200Ω (red-red-red) resistor in a step that calls for a 1200Ω (brown-red-red) resistor.
4. Recheck the wiring. Trace each lead in colored pencil on the Pictorial as you check it. It is frequently helpful to have a friend check your work. Someone who is not familiar with the unit may notice something you have consistently overlooked.
5. Check all component leads connected to the circuit boards. Make sure the leads do not extend too far through the circuit board and make contact with other connections or parts.
6. Check all of the wires that are connected to the circuit board to be sure the wires do not touch the chassis. Make sure all wires are properly soldered.
7. If the difficulty still is not cured, read the "Precautions for Bench Testing," then refer to the "Troubleshooting Chart."

Precautions for Bench Testing

- Be cautious when you test transistors. Although they have almost unlimited life when used properly, they are much more vulnerable to damage from excessive voltage and current than other circuit components.
- Be careful so you do not short any terminals to ground when you make voltage measurements. If the probe slips, for example, and shorts out a bias or voltage supply point, it may damage one or more components.

Do not remove any components from the circuit board while the Signal Tracer is turned on.

When you make repairs to the Signal Tracer, make sure you eliminate the cause as well as the effect of the trouble. If, for example, you find a damaged resistor, make sure you find out what (wiring error, etc.) caused the resistor to become damaged. If the cause is not eliminated, the replacement resistor may become damaged when the tracer is put back into operation.

Refer to the "X-Ray Views," "Identification Charts," and the "Schematic Diagram" to locate the various components.

Use a high impedance voltmeter to make the specified measurements in this section.

In an extreme case where you are unable to resolve a difficulty, refer to the "Customer Service" information inside the rear cover of the Manual. Your warranty is located inside the front cover.

Troubleshooting Chart

This chart lists the "Condition" and "Possible Cause" of specific malfunctions. If a particular part or parts are mentioned (Q1 for example) as a possible cause, check that part to see if it was installed and/or wired correctly. It is also possible, on rare occasions, for a part to be faulty and require replacement.

CONDITION	POSSIBLE CAUSE
No sound from the speaker.	<ol style="list-style-type: none"> 1. Defective speaker. 2. Q4 through Q8 installed incorrectly. 3. D6, D7 installed backwards. 4. C7 open.
No operation in Audible V/ Ω position, Signal Tracer OK.	<ol style="list-style-type: none"> 1. Q3 installed incorrectly. 2. D4, D5 installed backwards.
No operation in Signal Tracer position, Audible V/ Ω OK.	<ol style="list-style-type: none"> 1. Q1, Q2 installed incorrectly. 2. D2, D3 installed backwards.
No detection or weak detection on RF signals.	<ol style="list-style-type: none"> 1. D1 installed backwards. 2. Probe switch in wrong position. 3. Probe switch wired incorrectly.

CIRCUIT DESCRIPTION

Refer to the Schematic Diagram (Illustration Booklet, Page 5) while you read this circuit description.

The Signal Tracer is basically a hi-gain amplifier. It features a diode-equipped probe which acts as an RF detector. A relaxation oscillator provides an audible volt/ohmmeter function.

A high-impedance input stage is formed by transistors Q1 and Q2 which are connected in a complementary amplifier configuration. The stage also provides a voltage gain. The high impedance is a function of the Darlington transistor, Q1. Diodes D2 and D3 provide input voltage protection. Diode D1, which is located in the probe, can be switched in to provide detector action in RF circuits. Capacitor C1, which is in series with diode D1, blocks any DC present on the RF signal.

The audible volt/ohmmeter (logic tracer) circuit is provided by unijunction transistor Q3, which is connected as a relaxation oscillator. The circuit charges capacitor C10 to the "firing potential" of transistor Q3, at which time the transistor conducts and discharges C10. This discharge provides a pulse to the audio amplifier through capacitor C4. Any voltage

above the firing voltage of transistor Q3 (normally 4 to 6 volts) will be sufficient to operate the circuit. Since this circuit returns to -9 volts, voltage levels down to approximately -3 volts can be determined. The audible ohmmeter functions when the probe tip is touched to the test point. The frequency of the tone produced will vary when more or less resistance is inserted in series with the probe.

Function switch SW1 selects either the audio preamplifier (signal tracer) or the relaxation oscillator Q3 (Audible V/ Ω). SW1 connects the signal to the audio amplifier through Level control R10 and coupling capacitor C5. Transistor Q4 is an audio amplifier which connects the amplified signal directly to the base of the audio driver, Q5. The amplified signal from Q5 is connected directly to the complementary output stage, which consists of transistors Q7 and Q8, and diodes D6 and D7.

Transistor Q6 acts as a current limiter to prevent current drain on the batteries. Resistor R21 and capacitors C8 and C9 provide power supply isolation between the preamplifier and power amplifier circuitry. The Signal Tracer may be powered by batteries or the optional power supply, Model IPA-5280-1.

CIRCUIT BOARD X-RAY VIEW

NOTE: To find the PART NUMBER of a component for the purpose of ordering a replacement part:

- A. Find the circuit component number (R5, C3, etc.) on the X-Ray View.
- B. Locate this same number in the "Circuit Component Number" column of the "Parts List" in the front of this Manual.
- C. Adjacent to the circuit component number, you will find the PART NUMBER and DESCRIPTION which must be supplied when you order a replacement part.

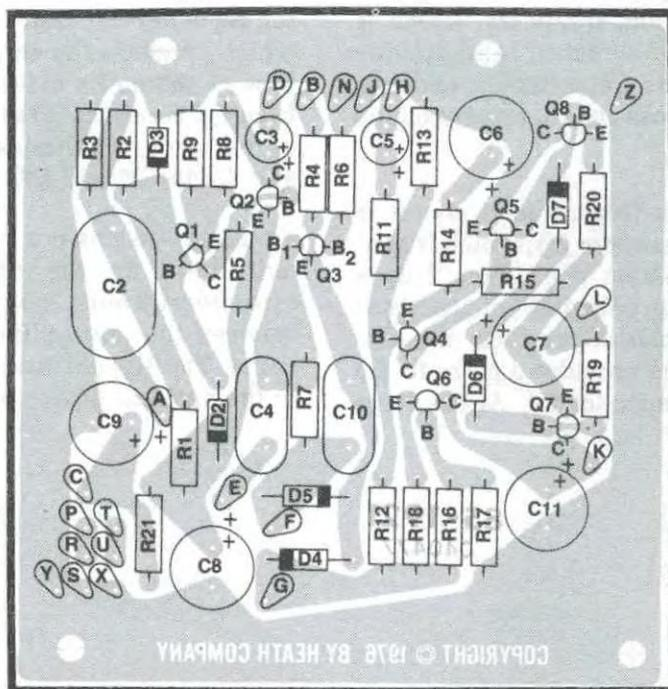

VIEWS FROM COMPONENT SIDE

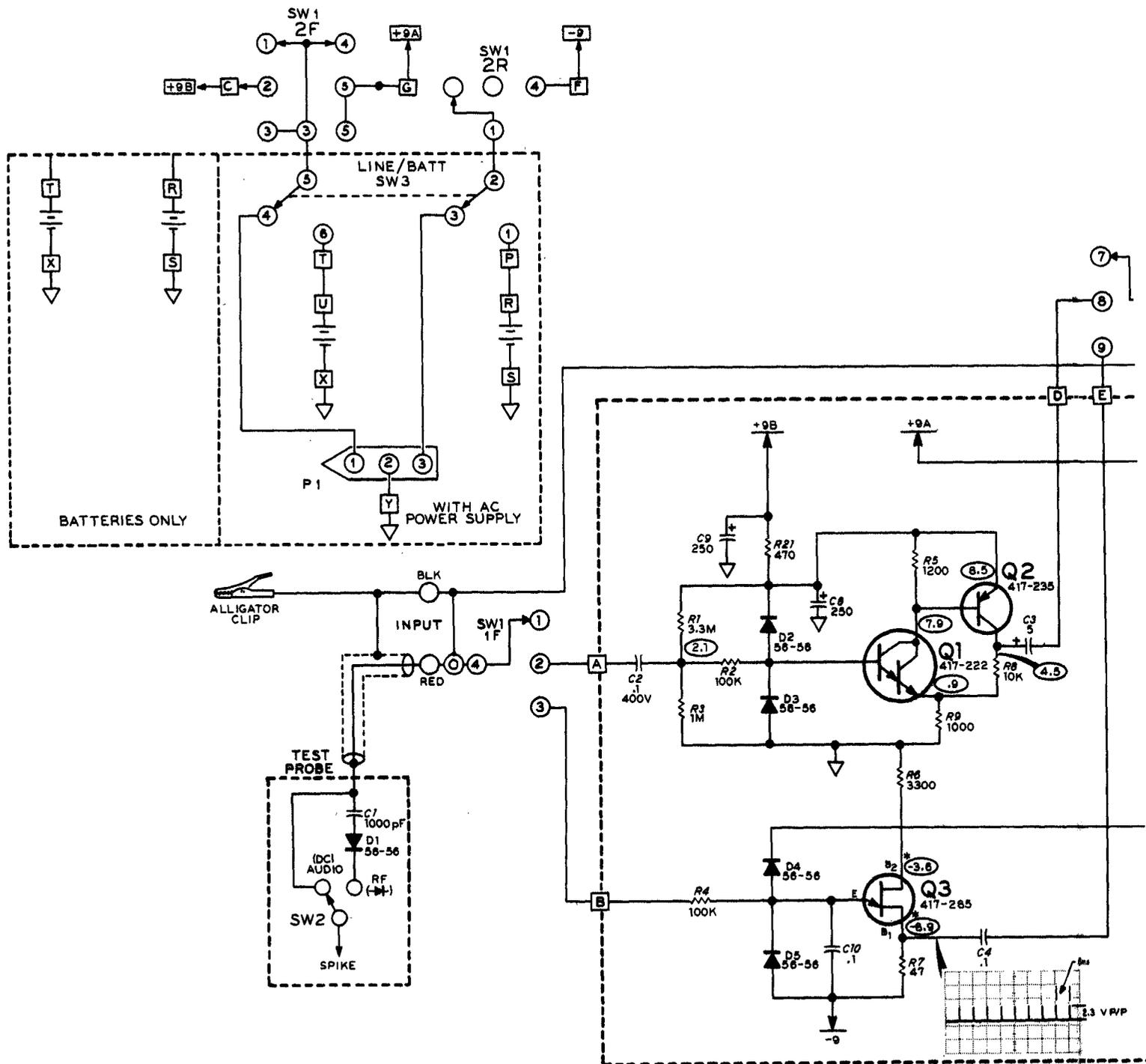

**SCHEMATIC OF THE
HEATHKIT®
MODEL IT-5283
SIGNALTRACER**

NOTES:

1. ALL RESISTORS ARE 1/2 WATT. RESISTOR VALUES ARE IN OHMS (k-1000, M-1, 000, 000).
2. CAPACITORS ARE IN μ F.
3. SW1 IS A ROTARY SWITCH AND SW2 IS IN THE PROBE.
4. ○ THIS SYMBOL INDICATES A DC VOLTAGE TAKEN UNDER THE FOLLOWING CONDITIONS FROM THE POINT INDICATED TO CHASSIS GROUND WITH A HIGH IMPEDANCE VOLTMETER:
A. SW1 IS IN THE SIGNAL TRACER POSITION.
B. LEVEL CONTROL IS FULLY COUNTERCLOCKWISE (CCW).

5. ○ THIS SYMBOL INDICATES THE FOLLOWING DC VOLTAGE TO CHASSIS GROUND WITH A VOLTMETER:
A. SW1 IN THE SIGNAL TRACER POSITION.
B. LEVEL CONTROL IS FULLY COUNTERCLOCKWISE (CCW).
C. INPUT SIGNAL IS ZERO.
6. ▽ THIS SYMBOL INDICATES A SIGNAL MEASURED AT THE POINT INDICATED TO CHASSIS GROUND WITH A VOLTMETER.
7. □ THIS SYMBOL INDICATES A CONNECTION POINT TO CHASSIS GROUND.

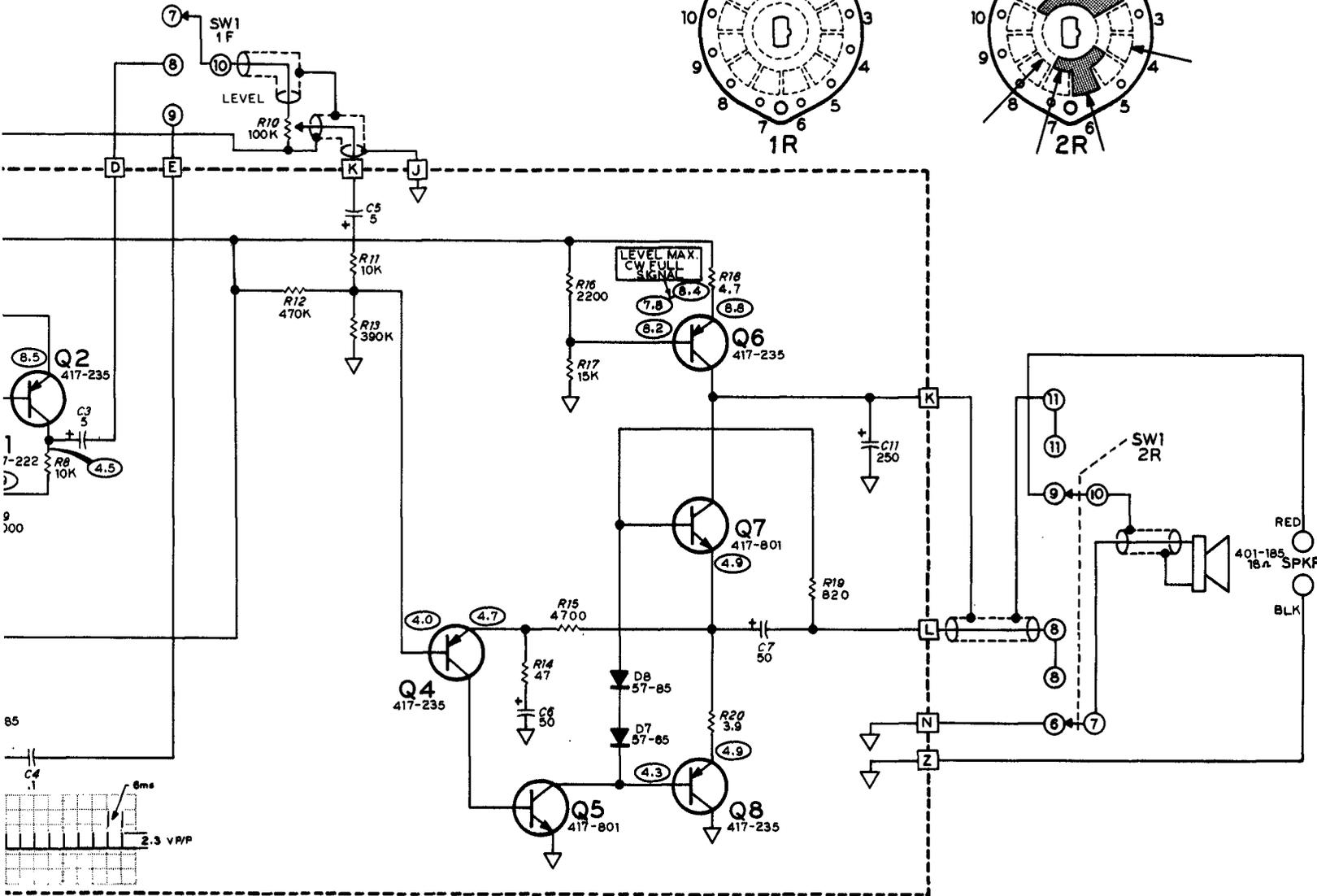
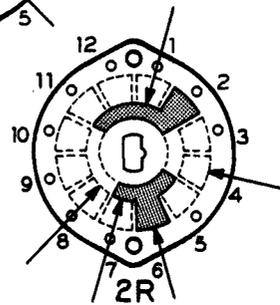
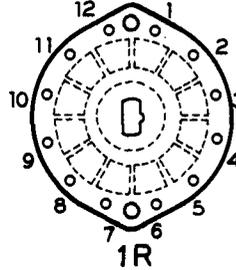
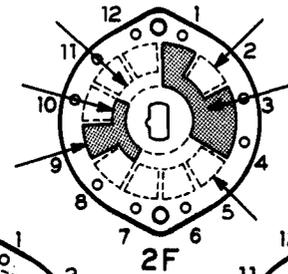
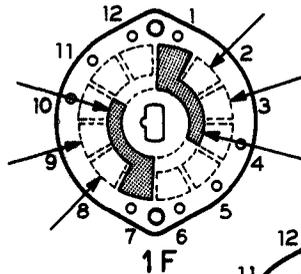
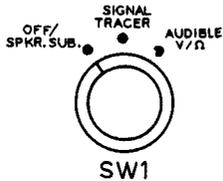

5. THIS SYMBOL INDICATES A DC VOLTAGE TAKEN UNDER THE FOLLOWING CONDITIONS FROM THE POINT INDICATED TO CHASSIS GROUND WITH A HIGH IMPEDANCE VOLTMETER:

- A. SW1 IS IN THE AUDIBLE V/Ω POSITION.
- B. LEVEL CONTROL IS FULLY COUNTERCLOCKWISE (CCW).
- C. INPUT IS GROUNDED.

6. THIS SYMBOL INDICATES CIRCUIT GROUND.

7. THIS SYMBOL INDICATES A LETTERED CIRCUIT BOARD CONNECTION.

8. THIS SYMBOL INDICATES A NUMBERED SWITCH LUG CONNECTION.

9. VOLTAGES MAY VARY ±5%.

10. 1F, 1R, 2F, AND 2R ARE PART OF ROTARY SWITCH SW1.

11. WAVEFORM AT Q3 IS TAKEN WITH THE PROBE SHORTED TO THE CHASSIS AND SW1 IN AUDIBLE V/Ω POSITION.