



## IMPORTANT NOTICE

Please make the following changes in your Manual before you start to assemble your kit.

Page 10 — Right column, under "Plastic Parts." (This part is no longer required with your kit.)

Delete: "G5 432-199 1 Wire nut"

— Right column, under "Hardware." Change the 13th item . . .

From: "H14 252-3 57 6-32 nut"

To: "H14 252-3 59 6-32 nut"

Page 11 — Right column, under "Insulators — Grommets — Terminal Strips — Connectors (cont'd)." Change the 14th item . . .

From: "L14 432-137 10 Connector tab"

To: "L14 432-137 12 Push-on connector"

— Right column, under "Wire — Cable — Sleeving."

Change the seventh item . . .

From: "344-2 36" Medium black stranded wire"

To: "344-2 66" Medium black stranded wire"

Change the 15th item . . .

From: "346-20 12" Large black heat-shrinkable sleeving"

To: "346-20 15" Large black heat-shrinkable sleeving"

Page 12 — Left column, under "Miscellaneous." Change the last item . . .

From: "M4 420-601 1 Fan motor"

To: "M4 420-621 1 Fan motor"

Page 47 — Remove the new Page 47 from this Notice and tape it over Page 47 in your Manual.

Page 48 — Remove the new Page 48 from this Notice and tape it over Page 48 in your Manual.

Page 57 — Remove the new Page 57 from this Notice and tape it over Page 57 in your Manual.

Page 58 — Remove the new Page 58 from this Notice and tape it over Page 58 in your Manual.

Page 59 — Remove the new Page 59 from this Notice and tape it over Page 59 in your Manual.

#### **ILLUSTRATION BOOKLET**

Page 2 — Cross out the part illustrated at G5 (wire nut).

Page 9 — Cut out the new Pictorial 4-13 from this Notice and tape it over Pictorial 4-13 on Page 9 of the Illustration Booklet.

#### **ASSEMBLY MANUAL**

Page 62 — Turn this Page over. Then tape the new Page 62 over Page 62 in your Assembly Manual.

Thank you,

**HEATH COMPANY**

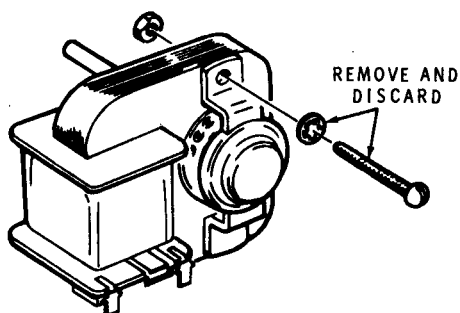

Detail 4-6E

- (✓) Refer to Detail 4-6E and carefully remove the mounting hardware from **one side** of the motor as shown. Discard the hardware.
- (✓) Refer to Detail 4-6F and, from the shaft side of the motor, insert a 6-32 × 1-9/16" black screw through the mounting hole. Then secure the screw with a #6 lockwasher and a 6-32 nut.
- (✓) In the same manner, modify the hardware on the other side of the motor. Be sure to install the new screw from the shaft side of the motor.
- (✓) Prepare both ends of a 13" and a 20" length of medium black stranded wire.

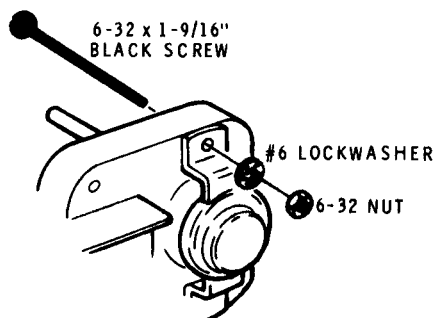

Detail 4-6F

- (✓) Refer to Detail 4-6G and prepare one end of both wires as follows:
  1. Crimp and solder a push-on connector (#432-137) onto one end of both wires as shown in Part A.
  2. Cut two 1-1/2" lengths of large black (heat shrinkable) sleeving. Place a length of sleeving on each wire.
  3. Slide the sleeving down until it is all the way to the end of the connector. With a match or other heat source, shrink the sleeving onto each connector as shown in Part B.

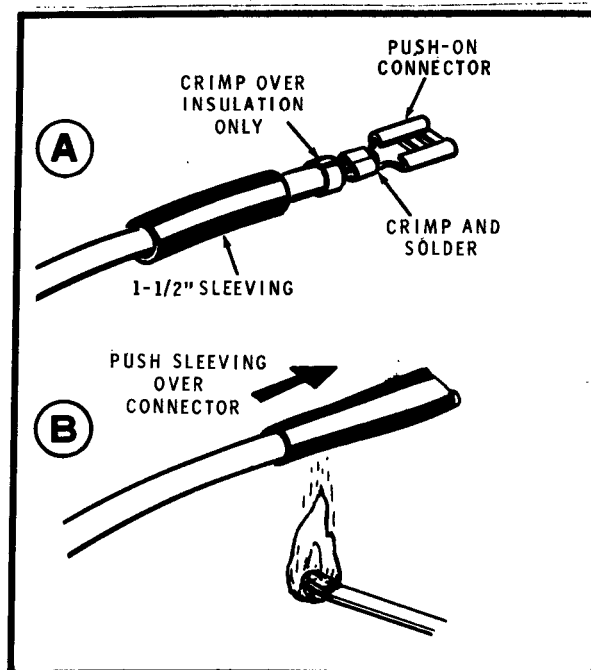

Detail 4-6G

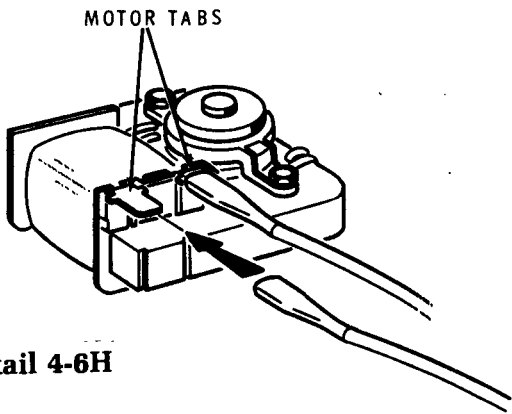

Detail 4-6H

- (✓) Refer to Detail 4-6H and push the connector on one of the prepared black wires onto one of the motor tabs, and push the other connector onto the remaining motor tab as shown.
- (✓) Position the rear panel as shown in Detail 4-6J. Then locate hole FK. This hole is 4" down from the top edge of the panel and 9" in from the right edge of the panel.
- (✓) Refer again to Detail 4-6J and mount the fan motor on the rear panel at holes FJ and FK. Use two 7/16" spacers, two #6 lockwashers, and two 6-32 nuts as shown. NOTE: When you have the motor mounted correctly, the sides of the motor frame will be parallel to the edges of the panel.

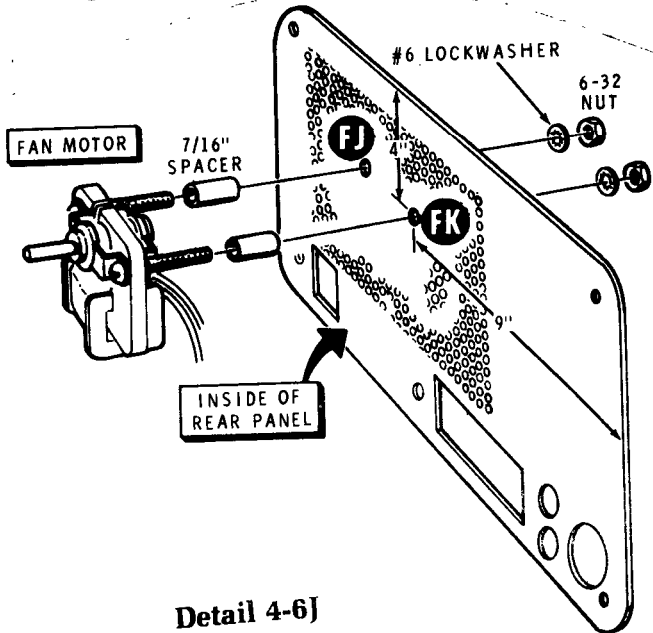

Detail 4-6J

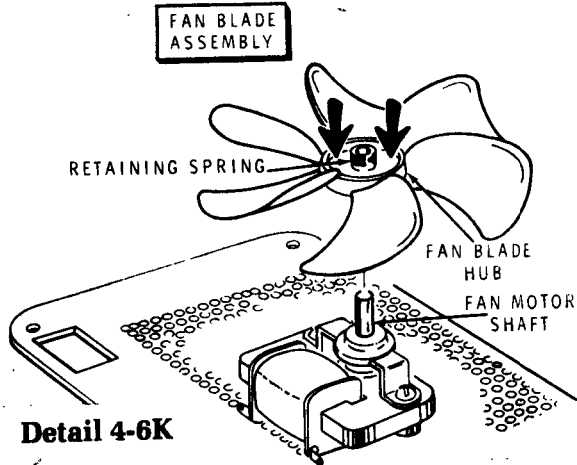

Detail 4-6K

- (✓) Refer to Detail 4-6K and install the fan blade assembly (#266-296) on the fan motor shaft. Position the fan motor and the blade assembly as shown, and apply firm downward pressure with both thumbs on the fan blade hub. A slight rocking motion will help. Push the fan blades onto the motor shaft until there is 1/16" to 1/32" clearance between the fan blade hub and the motor frame.
- ( ) Refer to Detail 4-6L and mount the rear panel to the chassis rear apron at FC and FD, and to the left side panel at FB. Use 6-32 x 3/8" hardware.
- ( ) Rotate the fan blades to make sure they do not hit anything. Reposition the motor mounting as necessary.

NOTE: The free ends of the motor wires will be connected later.

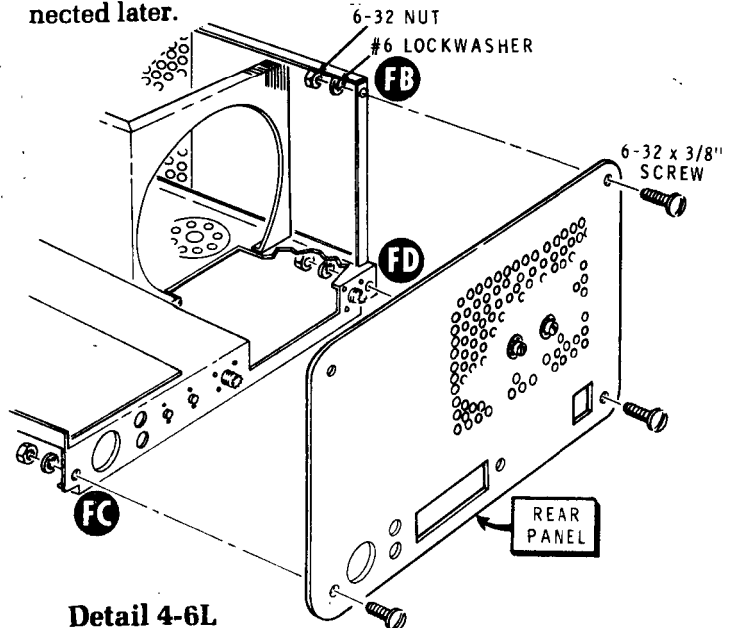

Detail 4-6L



- (✓) Cut four 1" lengths of large black (heat shrinkable) sleeving. Place a length of sleeving on each wire.
- (✓) Crimp and solder a push-on connector (#432-137) onto the free end of each wire.
- (✓) Slide the sleeving down until it is all the way to the end of the connector. With a match or other heat source, shrink the sleeving onto each connector.

NOTE: When you connect each of the four prepared wires, in the following steps, first push the male connector pin on the wire into the indicated hole of socket Y (until it locks in place). Then install the push-on connector on the other end of the wire onto the indicated lug of switch AN.

Connect the four prepared wires as follows:

- (✓) 13-1/2" red from socket Y hole 2 to switch AN lug 1.
- (✓) 13-1/2" black from socket Y hole 5 to switch AN lug 2.
- (✓) 14" white from socket Y hole 3 to switch AN lug 5.
- (✓) 15" red from socket Y hole 6 to switch AN lug 6.
- (✓) Prepare a 2" length of black hookup (solid) wire.
- (✓) Connect the 2" black wire between terminal strip BT lugs 3 (S-2) and 1 (NS).
- (✓) Connect the yellow hookup wire coming from grommet T to phono socket U lug 1 (NS).
- (✓) Connect the orange wire coming from grommet T to terminal strip BT lug 2 (NS).

NOTE: If necessary, refer to Detail 4-6G (Page 47) for the next three steps.

- (✓) Prepare a 4" length of large black stranded wire.
- ( ) Install one of the push-on connector tabs onto one end of the 4" large black stranded wire (S-1).

- (✓) Cut a 1-1/2" piece of large black heat-shrinkable sleeving. Shrink the sleeving over the end of the connector on the 4" wire.

Refer to Pictorial 4-10 (Illustration Booklet, Page 8) for the following steps.

- (✓) Install the push-on connector from the preceding step onto switch Z lug 3. Connect the other end of this wire to double lug AW (NS).
- (✓) Connect the black lead coming from grommet AK to double lug AW (NS). Make a secure mechanical connection.
- (✓) Locate the shielded cable coming from grommet T, the end of which is prepared as shown in Detail 4-10C. Connect the center conductor of this coaxial cable to terminal strip AG lug 1 (NS). Connect the shield lead to lug 2 (S-1). NOTE: Be sure this is the cable coming from filter FL1.

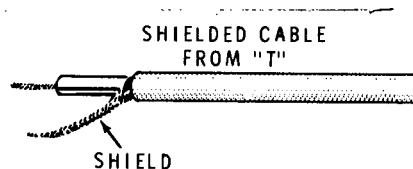

Detail 4-10C

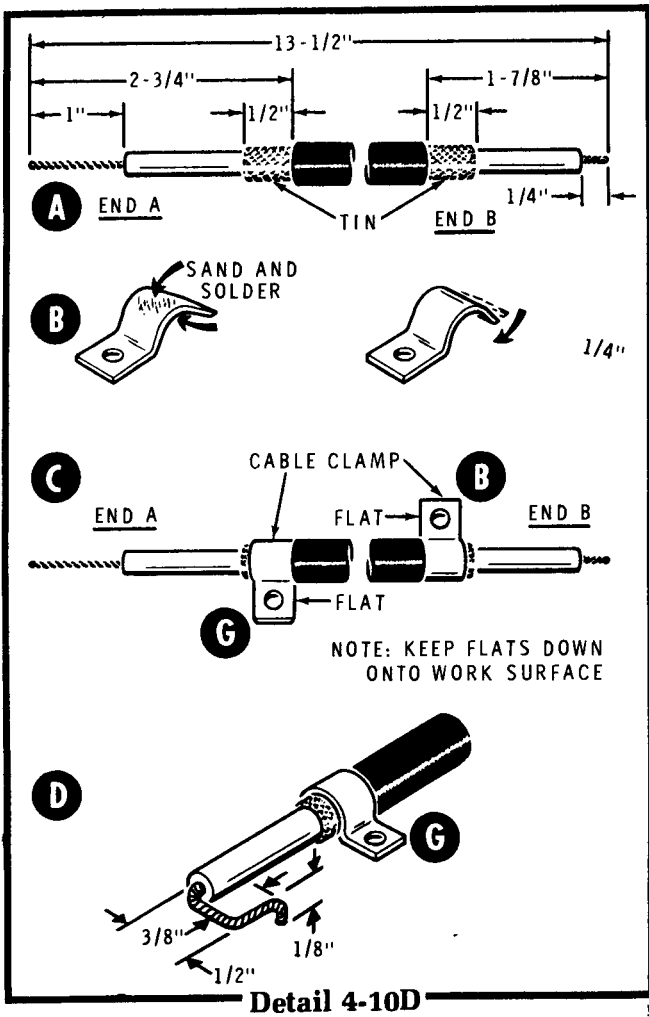

Detail 4-10D

Refer to Detail 4-10D for the next six steps.

1. Refer to Part A of the Detail and prepare a 13-1/2" length of RG-8/U coaxial cable as shown. Tin the exposed braid at each end, being careful not to melt the inner insulation.
2. Locate two cable clamps (#207-8). Refer to Part B of the Detail and on the inside and on top of the curved portion of each clamp, thoroughly sand each clamp to remove the outer coating. Apply a good coating of solder to both the inside and outside of the sanded clamp (only the curved portion).
3. Slightly squeeze the curved portion of both clamps to form a symmetrical half-circle.

NOTE: Carefully study Part C of Detail 4-10D and note the position of the clamps at end A and at end B of the

cable. When you install the clamps, both of them must fit over the tinned cable braid, and the flat on each of them must be flat against the top of your work surface.

4. Install and solder a cable clamp onto end A of the 13-1/2" shielded cable exactly as shown in Part C of the Detail.
5. Similarly, install and solder the other cable clamp on end B of the cable.
6. Refer to Part D of Detail 4-10D and form the inner lead at end A of the shielded cable as shown.

Refer to Detail 4-10E for the next two steps.

- At end A of the RG-8/U coaxial cable, connect the inner lead to relay K1 lug 8 (S-1).

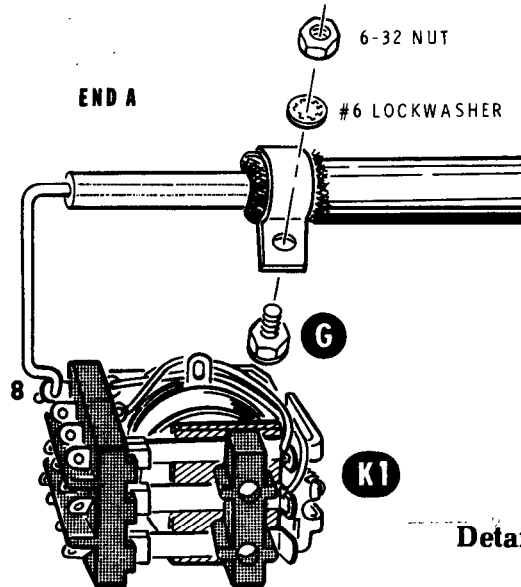

Detail 4-10E

- Secure the cable clamp at cable end A to the end of the screw at G with a #6 lockwasher and a 6-32 nut.
- Refer to Detail 4-10H and, at cable end B, solder the inner lead to coaxial jack A (S-1). Then secure the cable clamp to the top of the 5/16" tapped spacer at B with a #6 lockwasher and 6-32 x 3/16" screw as shown.

Refer to Pictorial 4-11 (Illustration Booklet, Page 8) for the following steps.

- Cut three 1" pieces of large black (heat-shrinkable) sleeving.

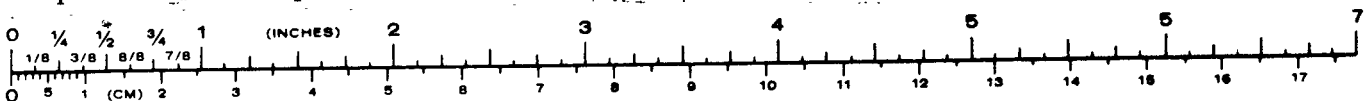

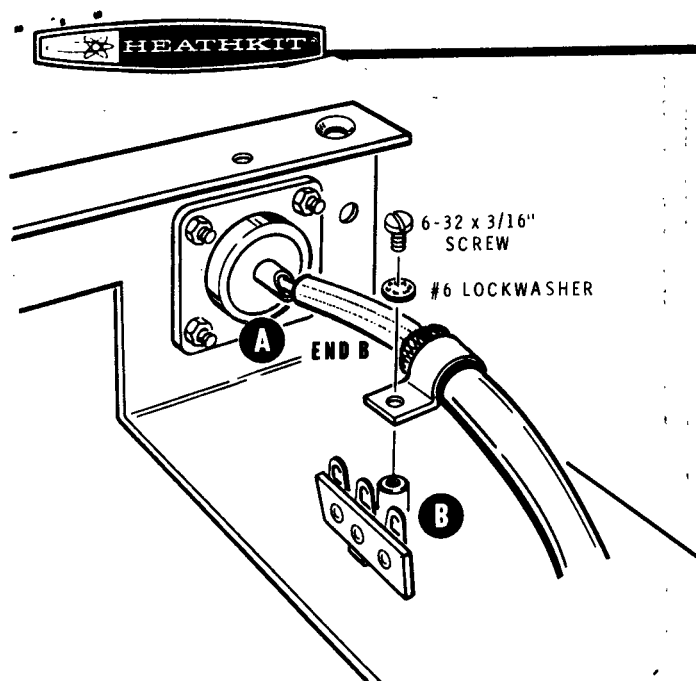

Detail 4-10H

- (✓) Prepare the following lengths of large black stranded wire:

4-1/2"

13-1/2"

13-1/2"

- (✓) Install a push-on connector (#432-137) and a 1-1/2" sleeve on one end of each of the three wires. Shrink the sleeve onto the wires and connectors as in a previous step.

- (✓) Push the connector on the 4-1/2" wire onto switch AN lug 4.

- (✓) Push the connector on one of the 13-1/2" wires onto switch Z lug 1.

- (✓) Push the connector on the other 13-1/2" wire onto switch Z lug 2.

- (✓) Prepare a 12-1/2" length of large black stranded wire.

- (✓) Connect the free end of the black-yellow wire coming from grommet AK and one end of the 12-1/2" wire prepared in the preceding step to one push-on connector (S-2). Then push this connector onto switch AN lug 3.

- (✓) Solder the free end of the black-red lead coming from grommet AK and the free end of the black wire coming from lug 4 of switch AN to one push-on connector (S-2). Push this connector onto switch Z lug 4.

The free ends of the "tabbed" wires prepared in the preceding steps will be connected later.

- (✓) D16: Refer to the Detail 4-11A (Illustration Booklet, Page 8) and connect a 1N2071 diode (#57-27) between terminal strip BT lugs 4 (S-2) and 5 (NS). Be sure to position the banded end as shown in Pictorial 4-11.

- (✓) R5: Connect a 27 k $\Omega$  (red-violet-orange) resistor between terminal strip BT lugs 1 (NS) and 2 (NS).

- (✓) Cut two 1/2" pieces of small black sleeving.

- (✓) R4: Place a 1/2" piece of sleeving on each lead of a 27 k $\Omega$  (red-violet-orange) resistor. Then connect the resistor between terminal strip BT lugs 2 (S-3) and 5 (NS).

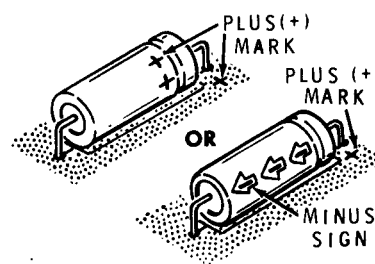

Detail 4-11B

- (✓) C4: Refer to Detail 4-11B and connect the positive (+) lead of a 20  $\mu$ F electrolytic capacitor to terminal strip BT lug 5 (NS). Connect the other lead to lug 1 (S-3).

- (✓) Connect the black stranded wire coming from grommet AL to relay K1 lug 6 (S-1).

- (✓) Prepare a 2" and an 8-1/2" red wire.

- (✓) Connect a 2" red wire between relay K1 lugs 3 (NS) and 11 (S-1).

- (✓) Connect an 8-1/2" length of red wire from terminal strip BT lug 5 (S-4) to relay K1 lug 3 (NS).

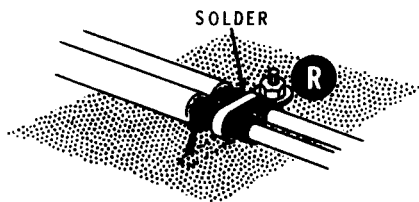

Detail 4-12E

- (✓) Refer to Detail 4-12E and position the prepared shields of the coaxial cables connected in the two preceding steps, over long solder lug R. Bend the solder lug back over both shield braids and solder. Use a minimum, but adequate, amount of heat.
- (✓) Connect the center conductor at the free end of the coaxial cable coming from relay K1 lug 7 to the center conductor of coaxial jack L (S-1). Connect the shield wires to phono socket U lug 2 (S-1).
- (✓) Cut two 1/4" pieces of small black sleeving.
- (✓) Cut both leads of a 100 kΩ resistor (brown-black-yellow) to 1/2".
- (✓) R27: Place a 1/4" sleeve on each resistor lead. Then connect the 100 kΩ resistor between relay K1 lugs 9 (S-2) and 3 (S-3) as shown in inset drawing 2 of the Pictorial.

Refer to Pictorial 4-13 (Illustration Booklet, Page 9) for the following steps.

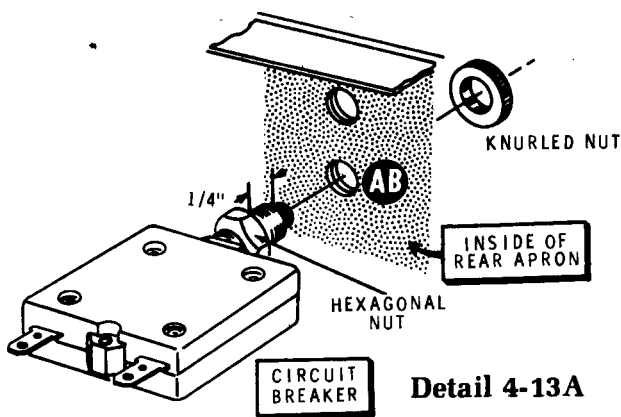

Detail 4-13A

Refer to Detail 4-13A for the following three steps.

- (✓) Remove a knurled nut from each of the two circuit breakers (#65-28).
- (✓) Position the face of each hexagonal nut 1/4" from the end of the mounting bushing.
- (✓) CB1: Mount a circuit breaker on the chassis rear apron at AB. Use the knurled nut provided. NOTE: For convenience in wiring, position the solder lugs to provide the maximum distance between the chassis and the lugs.
- (✓) CB2: In the same manner, mount the other circuit breaker at AA.
- (✓) Locate the shorter medium black wire coming from the fan motor. Connect the end of this wire to terminal strip AE lug 2 (NS).
- (✓) Locate the remaining fan motor wire. Route the end of this wire forward to the front panel. Then connect the wire end to double lug AW (S-4).
- (✓) Position the fan wires as shown in Pictorial 4-13, making sure they are completely away from the fan blades.



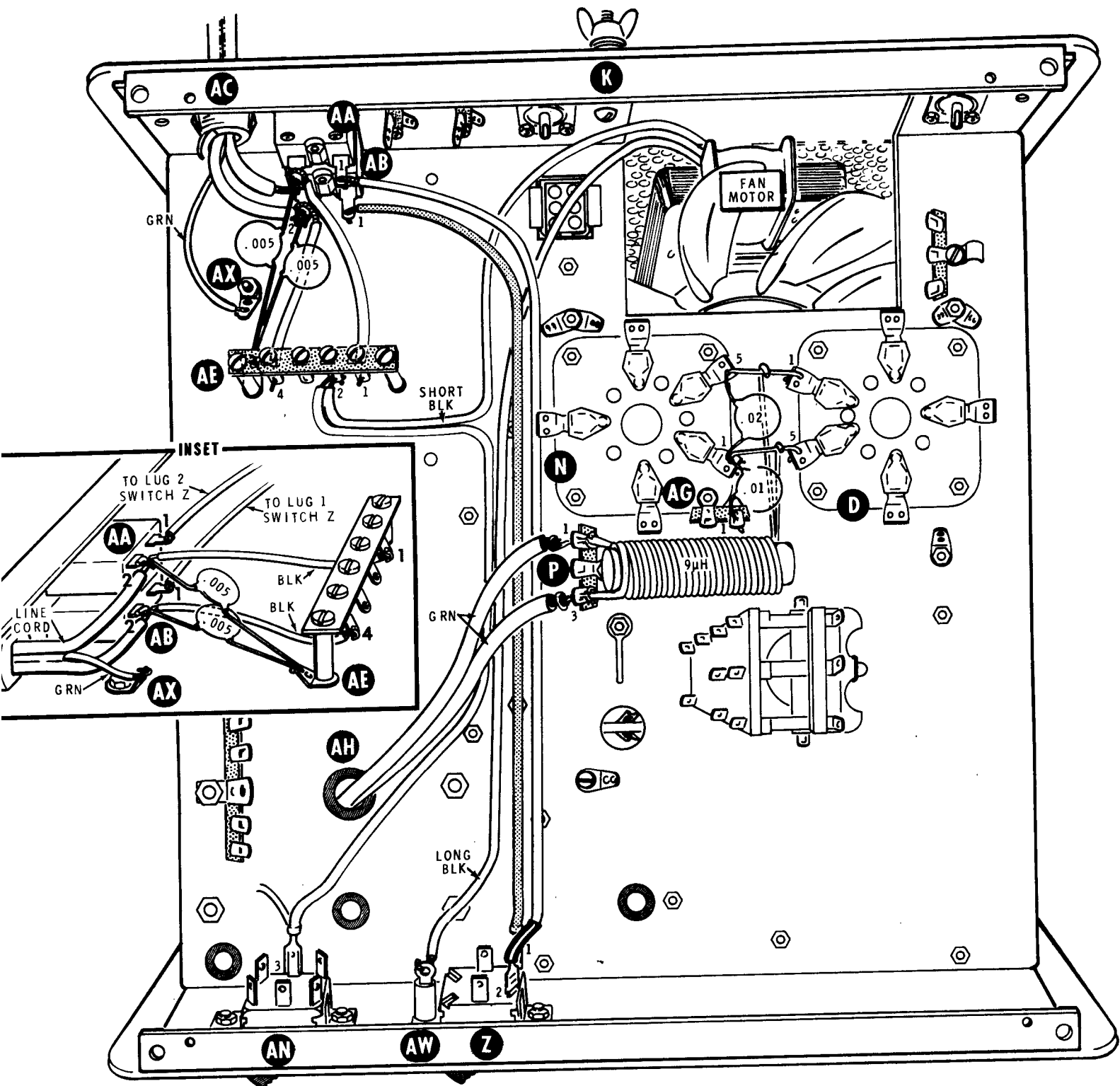

PICTORIAL 4-13

# Heathkit® Manual

for the

## LINEAR AMPLIFIER

Model SB-221

595-2201-04

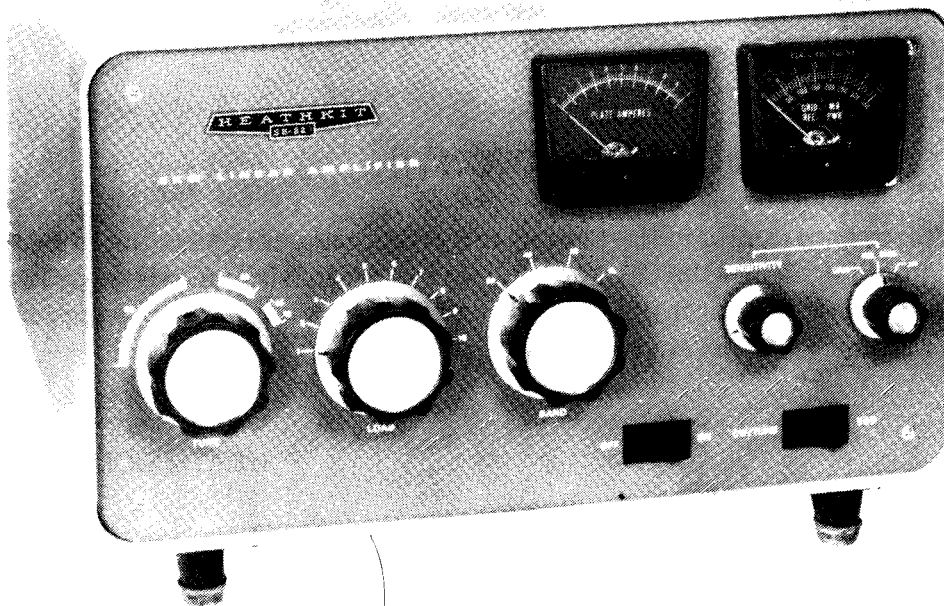

HEATH COMPANY  
BENTON HARBOR, MICHIGAN 49022

Copyright © 1978  
Heath Company  
All Rights Reserved  
Printed in the United States of America

"Federal Communications Commission requirements prescribe type acceptance of linear power amplifiers operating below 144 MHz in Part 97 of the Rules and Regulations. This Linear Amplifier will meet these requirements when constructed in strict accordance with the instructions in this manual, using only components and materials supplied with the kit or the exact equivalent thereof. You will be instructed to sign, date, place your amateur call sign, class of license, expiration date of license on the enclosed label and affix the label to the linear amplifier certifying that you have constructed this linear amplifier in accordance with the above mentioned instructions. In order to meet legal requirements, be certain to follow the instructions exactly as they are stated in this Manual."

WARNING: TO PREVENT FIRE OR SHOCK HAZARD, DO NOT EXPOSE THIS LINEAR AMPLIFIER TO RAIN OR MOISTURE.

### **CAUTION**

**Use extreme care during initial testing and all subsequent operation of this Linear Amplifier. While the SB-221 is designed for maximum safety, never lose respect for the high voltage present in this unit. Protect yourself always against lethal or severe electric shock.**

HEATH COMPANY



## TABLE OF CONTENTS

INTRODUCTION .....	4	OPERATION	
UNPACKING .....	5	Controls, Connectors, And Meters .....	78
ASSEMBLY NOTES .....	6	General .....	79
		Tune-Up .....	80
		Periodic Maintenance .....	82
PARTS LIST .....	9	IN CASE OF DIFFICULTY .....	84
		Special Shipping Instructions .....	84
		Troubleshooting Chart .....	85
STEP-BY-STEP ASSEMBLY .....	13	SPECIFICATIONS .....	86
Circuit Board Assembly .....	14	CIRCUIT DESCRIPTION	
Circuit Board Prewiring .....	17	Power Supply .....	88
Input Coil Assembly .....	18	Relay .....	89
Front Panel .....	25	RF Circuits .....	90
Chassis		ALC Circuit .....	90
Chassis Parts Mounting .....	29	Metering Circuits .....	91
ALC Wiring .....	33	CIRCUIT BOARD X-RAY VIEW .....	92
Top-Chassis Assembly .....	34	CHASSIS PHOTOGRAPHS .....	93
Under-Chassis Wiring .....	55	SCHEMATIC .....	(fold-in)
120-240 Volt Wiring .....	65	WARRANTY .....	Inside front cover
Final Top-Chassis Wiring .....	67	CUSTOMER SERVICE .....	Inside rear cover
Cable Preparation .....	68		
Knob Installation .....	69		
TEST AND FINAL ASSEMBLY .....	72		
INSTALLATION .....	76		



## INTRODUCTION

The Heathkit Model SB-221 Linear Amplifier is a completely self-contained, table top, grounded grid, linear amplifier. It is designed to operate at the maximum amateur power limit on SSB, CW, and RTTY.

The Amplifier is designed to be used with exciters which deliver 100 watts or more output. It can be used with less driving power, but will give a lower output.

A broad-band, tuned input circuit for each band feeds the two Eimac 3-500Z triode tubes connected in grounded grid configuration. The tubes are biased beyond cut-off in the receive mode, and zener-regulated bias controls the idling current in the transmit mode. The tubes are cooled by a fan.

An ALC circuit develops negative voltage to be fed back to the exciter to reduce its gain when the Amplifier is overdriven.

The antenna change-over relay is normally actuated by exciter relay contacts to place the Amplifier in the transmit mode.

The Amplifier can be operated from either 120 VAC or 240 VAC 50/60 Hz lines and can be easily changed from one to the other. Operation from a 240 volt line is recommended. Each side of the line cord is equipped with a circuit breaker to protect against overloads.

An important feature of this Amplifier is that it can be tuned up at the one kilowatt limit and can then be switched to operate on SSB at two kilowatts P.E.P. input. As the switching changes both the voltage and current to the final tubes, the impedance remains the same and no additional adjustment of tuned circuits is required.

The tubes are "instant heating" types, and transmission may be started as soon as the Amplifier is switched on (after tune-up).

Here is a full legal-limit Amplifier that can take its place on your operating table and give you years of trouble-free pleasure. This Amplifier has a commanding voice.



## UNPACKING

Your Linear Amplifier components were shipped in two separate cartons. The smaller carton contains the power transformer for your kit. Keep the transformer in its original carton until it is called for in an assembly step.

First, you will be instructed to open the remainder of the carton in which this Manual was packed and to check the parts against the Parts List, starting on Page 9. When you have checked the contents of the larger carton, you will be directed to the "Step-by-Step Assembly" portion of the Manual.

Any part, or group of parts, that is packaged in a bag or envelope with a part number on it should be returned to its container after you identify it and remain there until it is actually used in a step. This will prevent

intermixing of parts and aid in part identification. Some parts, however, have been placed in a bag or envelope that is not marked with the actual part number but is instead marked with a packaging number that begins with the number "171-". These "171-" numbers are used for packaging purposes only and do not appear in the Manual Parts List. Open each bag or envelope that is marked with only a "171-" packaging number and identify the parts it contains.

Save all packaging material until all parts have been located and/or until you have finished all the assembly steps.

NOTE: Never use a "171-" packaging number if you must order replacement parts. Use only the part numbers listed in the Manual Parts Lists for this purpose.

# ASSEMBLY NOTES

## TOOLS

You will need these tools to assemble your kit.

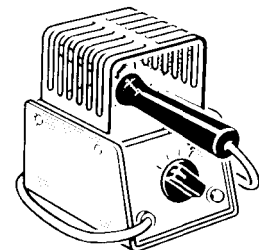
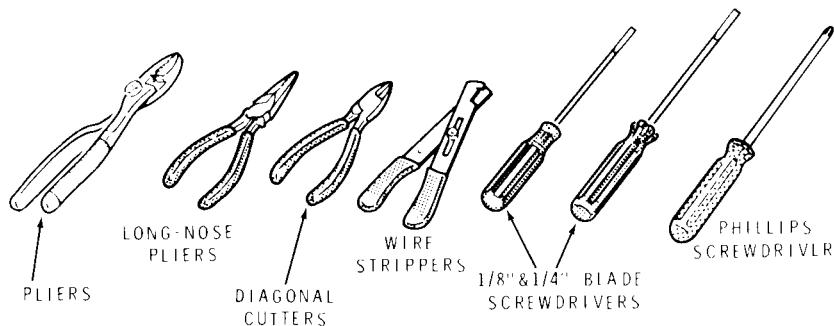

HEATHKIT  
SOLDERING  
IRON

OR

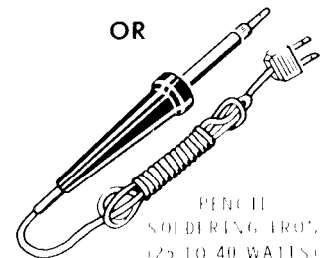

### OTHER HELPFUL TOOLS

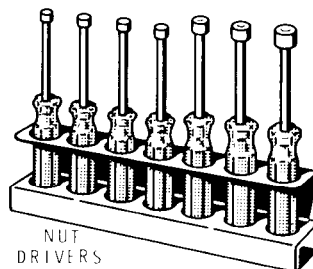
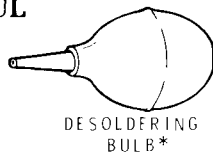

\*TO REMOVE SOLDER FROM CIRCUIT CONNECTIONS.

## ASSEMBLY

1. Follow the instructions carefully. Read the entire step before you perform each operation.
2. The illustrations in the Manual are called Pictorials and Details. Pictorials show the overall operation for a group of assembly steps; Details generally illustrate a single step. When you are directed to refer to a certain Pictorial "for the following steps," continue using that Pictorial until you are referred to another Pictorial for another group of steps.
3. Most kits use a separate "Illustration Booklet" that contains illustrations (Pictorials, Details, etc.) that are too large for the Assembly Manual. Keep the "Illustration Booklet" with the Assembly Manual. The illustrations in it are arranged in Pictorial number sequence.
4. Position all parts as shown in the Pictorials.
5. Solder a part or a group of parts only when you are instructed to do so.



6. Each circuit part in an electronic kit has its own component number (R2, C4, etc.). Use these numbers when you want to identify the same part in the various sections of the Manual. These numbers, which are especially useful if a part has to be replaced, appear:
- In the Parts List,
  - At the beginning of each step where a component is installed,
  - In some illustrations,
  - In the Schematic,
  - In the section at the rear of the Manual.
7. When you are instructed to cut something to a particular length, use the scales (rulers) provided at the bottom of the Manual pages.

**SAFETY WARNING: Avoid eye injury when you cut off excess lead lengths. Hold the leads so they cannot fly toward your eyes.**

## SOLDERING

Soldering is one of the most important operations you will perform while assembling your kit. A good solder connection will form an electrical connection between two parts, such as a component lead and a circuit board foil. A bad solder connection could prevent an otherwise well-assembled kit from operating properly.

It is easy to make a good solder connection if you follow a few simple rules:

1. Use the right type of soldering iron. A 25 to 40-watt pencil soldering iron with a 1/8" or 3/16" chisel or pyramid tip works best.
2. Keep the soldering iron tip clean. Wipe it often on a wet sponge or cloth; then apply solder to the tip to give the entire tip a wet look. This process is called tinning, and it will protect the tip and enable you to make good connections. When solder tends to "ball" or does not stick to the tip, the tip needs to be cleaned and retinned.

**NOTE:** Always use rosin core, radio-type solder (60:40 or 50:50 tin-lead content) for all of the soldering in this kit. This is the type we have supplied with the parts. The Warranty will be void and we will not service any kit in which acid core solder or paste has been used.



## PARTS

**Resistors** will be called out by their resistance value in  $\Omega$  (ohms),  $k\Omega$  (kilohms), or  $M\Omega$  (megohms). Certain types of resistors will have the value printed on the body, while others will be identified by a color code. The colors of the bands and the value will be given in the steps, therefore the following color code is given for information only.

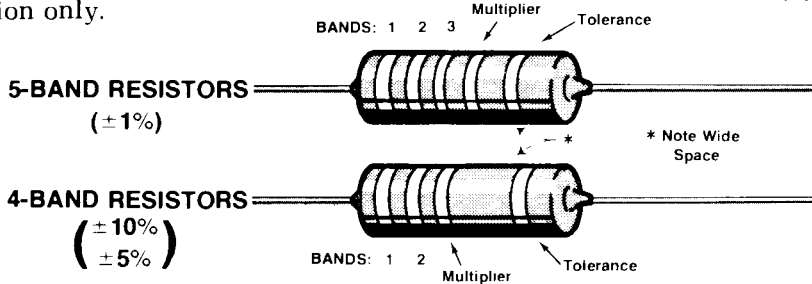
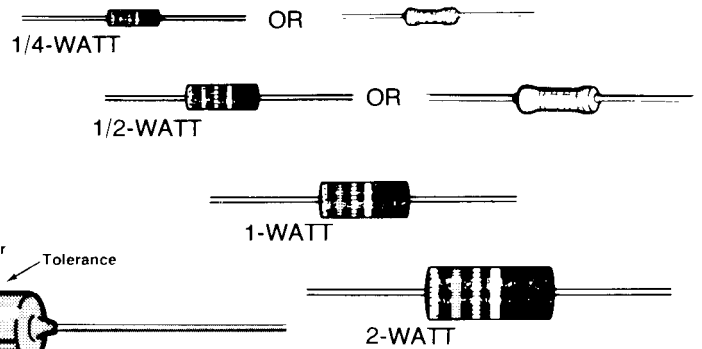

Band 1 1st Digit		Band 2 2nd Digit		Band 3 (if used) 3rd Digit		Multiplier		Resistance Tolerance	
Color	Digit	Color	Digit	Color	Digit	Color	Multiplier	Color	Tolerance
Black	0	Black	0	Black	0	Black	1	Silver	$\pm 10\%$
Brown	1	Brown	1	Brown	1	Brown	10	Gold	$\pm 5\%$
Red	2	Red	2	Red	2	Red	100	Brown	$\pm 1\%$
Orange	3	Orange	3	Orange	3	Orange	1,000		
Yellow	4	Yellow	4	Yellow	4	Yellow	10,000		
Green	5	Green	5	Green	5	Green	100,000		
Blue	6	Blue	6	Blue	6	Blue	1,000,000		
Violet	7	Violet	7	Violet	7	Silver	0.01		
Gray	8	Gray	8	Gray	8	Gold	0.1		
White	9	White	9	White	9				

**Capacitors** will be called out by their capacitance value in  $\mu F$  (microfarads) or  $pF$  (picofarads) and type: ceramic, Mylar\*, electrolytic, etc. Some capacitors may have their value printed in the following manner:

EXAMPLES:

$$151K = 15 \times 10 = 150 \text{ pF}$$

$$759 = 75 \times 0.1 = 7.5 \text{ pF}$$

NOTE: The letter "R" may be used at times to signify a decimal point: as in: 2R2 = 2.2 ( $pF$  or  $\mu F$ ).

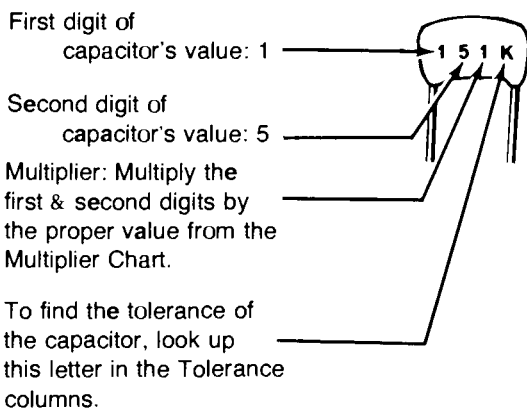

MULTIPLIER		TOLERANCE OF CAPACITOR		
FOR THE NUMBER:	MULTIPLY BY:	10 pF OR LESS	LETTER	OVER 10 pF
0	1	$\pm 0.1 \text{ pF}$	B	
1	10	$\pm 0.25 \text{ pF}$	C	
2	100	$\pm 0.5 \text{ pF}$	D	
3	1000	$\pm 1.0 \text{ pF}$	F	$\pm 1\%$
4	10,000	$\pm 2.0 \text{ pF}$	G	$\pm 2\%$
5	100,000		H	$\pm 3\%$
			J	$\pm 5\%$
8	0.01		K	$\pm 10\%$
9	0.1		M	$\pm 20\%$

\*DuPont Registered Trademark



# PARTS LIST

Check each part against the following list. The key numbers correspond to the numbers on the Parts Pictorial (Illustration Booklet Pages 1, 2, and 3).

To order a replacement part, always include the Part Number and use the Parts Order Form furnished with

this kit. If a Parts Order Form is not available, refer to "Replacement Parts" at the rear of this Manual. Your Warranty is inside the front cover. For prices, refer to the separate "Heath Parts Price List."

KEY No.	HEATH Part No.	QTY.	DESCRIPTION	CIRCUIT Comp. No.
<b>RESISTORS</b>				
<b>1/2-Watt</b>				
A1	6-102	1	1000 $\Omega$ (brown-black-red)	R25
A1	6-222	2	2200 $\Omega$ (red-red-red)	R21, R22
A1	6-562	1	5600 $\Omega$ (green-blue-red)	R9
A1	6-273	3	27 k $\Omega$ (red-violet-orange)	R4, R5, R11
A1	6-473	1	47 k $\Omega$ (yellow-violet-orange)	R23
A1	6-104	1	100 k $\Omega$ (brown-black-yellow)	R27
<b>Other Resistors</b>				
A2	1-8-1	1	68 k $\Omega$ , 1-watt (blue-gray-orange)	R24
A2	1-38-1	3	4.7 M $\Omega$ , 1-watt (yellow-violet-green)	R6, R7, R8
A2	3-1-2	1	.82 $\Omega$ , 2-watt, 1% (gray-red-silver) (same size as 1-watt)	R3
A3	3-25-5	1	1 $\Omega$ , 5-watt, 1% wire-wound	R1
A3	3-22-5	1	3600 $\Omega$ , 5-watt, 1% wire-wound	R2
A4	5-2-7	8	30 k $\Omega$ , 7-watt film	R12 through R19

KEY No.	HEATH Part No.	QTY.	DESCRIPTION	CIRCUIT Comp. No.
<b>CAPACITORS</b>				
<b>Mica</b>				
B1	20-149	1	150 pF	C41
B1	20-105	1	180 pF	C33
B1	20-124	6	115 pF	C16, C19, C26, C27, C28, C31
B1	20-106	1	390 pF	C36
B1	20-114	1	270 pF	C35
B1	20-116	2	400 pF	C34, C39
B1	20-184	2	680 pF	C37, C38
B2	20-711	1	500 pF	C56
<b>Ceramic</b>				
B3	21-79	1	.001 $\mu$ F, 6 KV	C7
B4	21-723	1	15 pF ceramic	C48
B4	21-140	2	.001 $\mu$ F, 500-volt	C47, C49
B4	21-70	1	.01 $\mu$ F	C32
B4	21-31	12	.02 $\mu$ F	C3, C5, C8, C21, C22, C23, C24, C25, C51, C52, C53, C54
B4	21-72	2	.005 $\mu$ F*	C1, C2

\* These parts are critical for continued safety. Replace them only with parts of the same rating or with the proper Heath parts.

KEY No.	HEATH Part No.	QTY.	DESCRIPTION	CIRCUIT Comp. No.
<b>Other Capacitors</b>				
B5	21-165	2	.001 $\mu$ F (1000 PF), 6 KV ceramic	C6, C29
B6	25-19	1	20 $\mu$ F (20 MFD) electrolytic	C4
B7	25-224	8	200 $\mu$ F (200 MFD) electrolytic	C10 through C17
B8	26-145	1	Load capacitor	C57
B9	26-164	1	Tune capacitor	C55

**CONTROLS—SWITCHES**

C1	10-12	1	100 k $\Omega$ control	R26
C2	61-14	1	DPST switch	SW1
C3	61-15	1	DPDT switch	SW2
C4	63-47	1	3-position rotary switch	SW3
C5	63-1338	1	4-position rotary switch	SW4
C6	63-1339	1	Rotary switch wafer	P/O SW4
C7	65-28	2	Circuit breaker	CB1, CB2
C8	69-55	1	TPDT relay	K1

**COILS—CHOKES—TRANSFORMERS**

D1	40-1666	1	80/20 plate coil	L5
D2	40-965	1	20-meter input coil	L1
D2	40-1963	1	40-meter input coil	L2
D2	40-1012	1	80-meter input coil	L3
D3	40-1950	1	Plate coil	L4
D4	45-53	2	Parasitic choke	PC1, PC2
D5	45-4	3	1 mH RF choke	RFC4, RFC5, RFC6
D6	45-6	1	8.5 mH RF choke	RFC2
D7	45-78	1	10.3 $\mu$ H RF choke	RFC3
D8	45-61	1	50 $\mu$ H RF choke	RFC1
D9	54-237	1	High-voltage transformer	T1
D9	54-238	1	Low-voltage transformer	T2

**DIODES—TUBES**

E1	56-24	1	1N458 diode	D18
E1	56-26	1	1N191 diode (brown-white-brown)	D17
E1	57-27	15	1N2071 diode	D1 through D14, D16
E2	56-82	1	1N3996A diode with hardware	ZD1
E3	411-245	2	3-500Z tube	V1, V2

KEY No.	HEATH Part No.	QTY.	DESCRIPTION
---------	----------------	------	-------------

**METAL PARTS**

F1	90-464	1	Cabinet
F2	200-1361	1	Chassis
F3	100-1022	1	Capacitor bank bracket
F4	100-1740	1	Coil shield/filter assembly
F5	203-1972-1	1	Front panel
F6	203-2006-1	1	Rear panel
F7	203-646	1	Left side panel
F8	203-645	1	Right side panel
F9	204-1041	2	Angle bracket
F10	204-2102	1	Plate coil bracket
F11	205-723	1	Top rear plate cover
F12	205-724	1	Perforated top cover
F13	205-1794	2	Transformer mounting plate
F14	205-1780	1	Rectangular spacer
F15	206-493	1	RF shield
F16	258-115	1	5/8" $\times$ 3-1/2" brass spring
F17	260-12	2	Plate connector
F18	456-16	1	Shaft coupler

**PLASTIC PARTS**

G1	255-59	2	Black tapered spacer
G2	261-9	4	Foot
	266-296	1	Fan blade
G3	354-5	6	Cable tie
G4	453-135	1	Phenolic shaft
G5	432-199	1	Wire nut

**HARDWARE**

NOTE: Hardware packets are marked to show the size of the hardware they contain (HDW #4, HDW #6, etc.). You may have to open more than one packet in this pack to locate all of the hardware of any one size (#6, for example).

**#6 Hardware**

H1	250-138	10	6-32 $\times$ 3/16" screw
H2	250-56	23	6-32 $\times$ 1/4" screw
H3	250-416	1	6-32 $\times$ 1/4" flat head screw
H4	250-8	31	#6 $\times$ 3/8" sheet metal screw
H5	250-434	19	6-32 $\times$ 3/8" flat head screw
H6	250-89	11	6-32 $\times$ 3/8" screw
H7	250-218	4	6-32 $\times$ 3/8" phillips head screw
H8	250-162	4	6-32 $\times$ 1/2" screw
H9	250-206	13	6-32 $\times$ 11/16" screw
H10	250-40	2	6-32 $\times$ 1-1/2" screw
H11	250-1284	2	6-32 $\times$ 1-9/16" black screw
H12	250-47	1	6-32 $\times$ 2" screw
H13	252-3	57	6-32 nut
H14	253-1	17	#6 fiber flat washer
H15	253-2	2	#6 fiber shoulder washer



KEY HEATH QTY. DESCRIPTION  
No. Part No.

**Hardware (cont'd.)**

H16	254-1	72	#6 lockwasher
H17	255-77	2	7/16" spacer
H18	255-103	1	6-32 × 5/16" tapped metal spacer
H19	255-71	4	6-32 × 3/4" tapped metal spacer
H20	255-21	3	6-32 × 7/8" tapped metal spacer
H21	255-129	1	6-32 × 1-1/2" tapped metal spacer
H22	259-1	20	#6 solder lug

**#8 Hardware**

J1	250-43	8	8-32 × 1/4" setscrew
J2	250-137	4	8-32 × 3/8" screw
J3	252-4	4	8-32 nut
J4	253-9	4	#8 flat washer
J5	254-2	5	#8 lockwasher
J6	255-66	1	8-32 × 1-3/8" spacer

**#10 Hardware**

J7	250-126	4	10-32 × 1/2" screw
J8	250-331	1	10-32 × 1" screw
J9	252-5	1	10-32 nut
J10	252-163	1	10-32 wing nut
J11	254-3	2	#10 lockwasher

**Other Hardware**

K1	207-8	2	Cable clamp
K2	250-213	8	4-40 × 5/15" screw
K3	252-15	8	4-40 nut
K4	252-7	3	Control nut
K5	252-10	2	Push-on nut
K6	253-10	2	Control flat washer
K7	253-42	1	1/2" flat washer
K8	253-19	5	3/4" flat washer
K9	254-5	2	Control lockwasher
K10	254-9	8	#4 lockwasher
K11	259-25	1	#10 double lug
K12	259-16	1	#10 spade lug
K13	259-10	1	Control solder lug
K14	259-24	1	Long solder lug

**INSULATORS—GROMMETS—TERMINAL STRIPS—CONNECTORS**

L1	71-2	1	Ceramic feedthrough insulator (disassembled in bag)
----	------	---	---

CIRCUIT  
Comp. No.

KEY HEATH QTY. DESCRIPTION  
No. Part No.

**Insulators—Grommets—Terminal Strips—Connectors (cont'd.)**

L2	73-4	1	5/16" grommet
L3	73-3	3	1/2" grommet
L4	73-2	1	3/4" grommet
L5	75-123	1	Line cord strain relief
	75-124	1	6" × 4-1/2" paper insulator
L6	75-125	8	Capacitor mounting insulator
L7	255-39	1	6-32 × 1-1/4" tapped phenolic spacer
L8	255-42	3	6-32 × 3/4" tapped phenolic spacer
L9	431-14	1	2-lug terminal strip
L10	431-10	3	3-lug terminal strip
L11	431-42	1	5-lug terminal strip
L12	431-20	1	6-lug terminal strip
L13	431-13	1	4-screw terminal strip
L14	432-137	10	Connector tab
L15	432-862	6	Male connector pin
L16	432-982	6	Female connector pin
L17	432-1090	1	Socket shell
L18	432-1091	1	Plug shell
L19	434-42	2	Phono socket
L20	434-93	2	5-lug ceramic tube socket
L21	436-5	2	Coaxial jack
L22	438-9	2	Coaxial plug
L23	438-12	1	Coaxial plug insert

**WIRE — CABLE — SLEEVING**

89-40	1	Line cord
134-36	2	Phono cable assembly
340-1	36"	Medium bare wire
340-4	4"	Large bare wire
343-2	84"	Coaxial cable, RG-58A/U
343-8	13"	Coaxial cable, RG-8/U
344-2	36"	Medium black stranded wire
344-7	84"	Large black stranded wire
344-13	13"	Blue hookup wire (thick insulation)
344-118	30"	Large red stranded wire
344-146	24"	Large white stranded wire
345-1	3-1/2"	Large metal braid
345-2	9"	Untinned braided wire
346-4	12"	Small black sleeving
346-20	12"	Large black (heat-shrinkable) sleeving
346-26	7"	Large clear sleeving
346-29	8-1/2"	Small clear sleeving

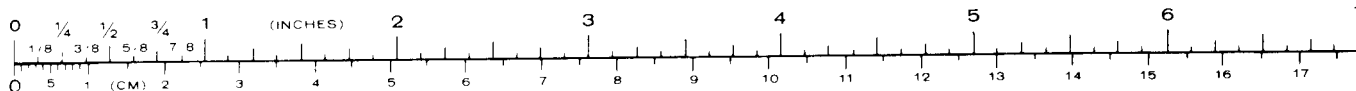



KEY No.	HEATH Part No.	QTY.	DESCRIPTION	CIRCUIT Comp. No.
---------	----------------	------	-------------	-------------------

**Hookup Wire (small solid)**

	344-50	36"	Black hookup wire	
	344-51	42"	Brown hookup wire	
	344-52	24"	Red hookup wire	
	344-53	24"	Orange hookup wire	
	344-54	24"	Yellow hookup wire	
	344-55	36"	Green hookup wire	
	344-56	18"	Blue hookup wire	

**MISCELLANEOUS**

	74-29	8"	Double-sided sticky tape	
	85-344-1	1	Printed circuit board	
^	M1	352-13	1 Silicone grease	M1
^	M2	407-145	1 Plate meter	M2
^	M3	407-146	1 Multi-meter	
^	M4	420-601	1 Fan motor	

KEY No.	HEATH Part No.	QTY.	DESCRIPTION
---------	----------------	------	-------------

	M5	462-191	2 Small knob
	M6	462-210	3 Large knob
		489-1	1 Sandpaper
	M7	490-5	1 Nut starter
			Solder

**PRINTED MATERIAL**

	390-147	1	"Danger High Voltage" label
	390-1499	1	FCC label
	391-34	1	Blue and white label
M8	391-615	1	"Heathkit" nameplate
	597-260	1	Parts Order Form
		1	Assembly Manual (See title page for part number)



## STEP-BY-STEP ASSEMBLY

The illustrations in this section of the Manual are called Pictorials and Details. Pictorials show the overall operation for a group of assembly steps; Details are used in addition to the Pictorials to illustrate a single step. When you are directed to refer to a certain Pictorial "for the following steps," continue using that Pictorial until you are referred to another Pictorial for another group of steps.

As the drawings in the Manual may be slightly distorted to show all the parts clearly, look at the Chassis Photos (Pages 91 through 94) from time to time to see the actual positions of wires and components.

Lockwashers and nuts will be used with most screws when mounting parts, unless the assembly steps state otherwise. Consequently, the applicable steps will call out only the size and type of hardware used. For example, the phrase "Use 6-32  $\times$  1/4" hardware" means to use 6-32  $\times$  1/4" screws, one or more #6 lockwashers, and 6-32 nuts. Refer to the Details for the proper installation of hardware. Be sure to position each part as shown in the Pictorials. Follow the instructions carefully, and read the entire step before performing the operation.

## CIRCUIT BOARD ASSEMBLY

### START

In the following steps, you will be given detailed instructions on how to install and solder the first part on the circuit board. Read and perform each step carefully. Then use the same procedure whenever you install parts on a circuit board.

- ( ) Position the circuit board as shown with the printed side (not the foil side) up.

NOTE: When you install a component that has its value printed on it, position the value marking up, so it can be easily read. Diodes should be mounted with their type or part number up, if possible.

- ( ) Hold a 5600  $\Omega$ , 1/2-watt (green-blue-red) resistor with long-nose pliers and bend the leads straight down to fit the hole spacing on the circuit board.

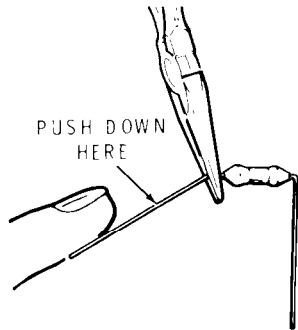

- ( ) R9: Push the leads through the holes at the indicated location on the circuit board. The end with color bands may be positioned either way.

- ( ) Press the resistor against the circuit board. Then bend the leads outward slightly to hold the resistor in place.

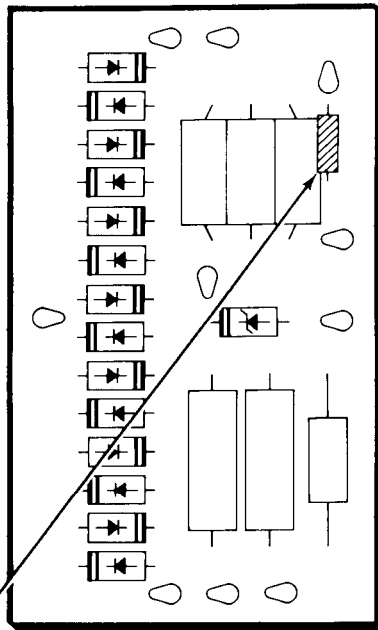

PICTORIAL 1-1

### CONTINUE

- ( ) Solder the resistor leads to the circuit board as follows:

1. Push the soldering iron tip against both the lead and the circuit board foil. Heat **both** for two or three seconds.

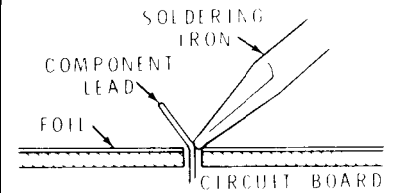

2. Then apply solder to the other side of the connection. **IMPORTANT:** Let the heated lead and the circuit board foil melt the solder.

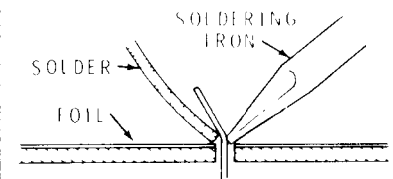

3. As the solder begins to melt, allow it to flow around the connection. Then remove the solder and the iron and let the connection cool.

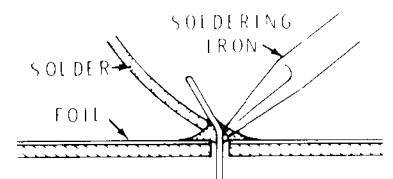

- ( ) Cut off the excess lead lengths close to the connection. **WARNING:** Clip the leads so the ends will not fly toward your eyes.

- ( ) Check each connection. Compare it to the illustrations on Page 15. After you have checked the solder connections, proceed with the assembly on Page 16. Use the same soldering procedure for each connection.

### A GOOD SOLDER CONNECTION

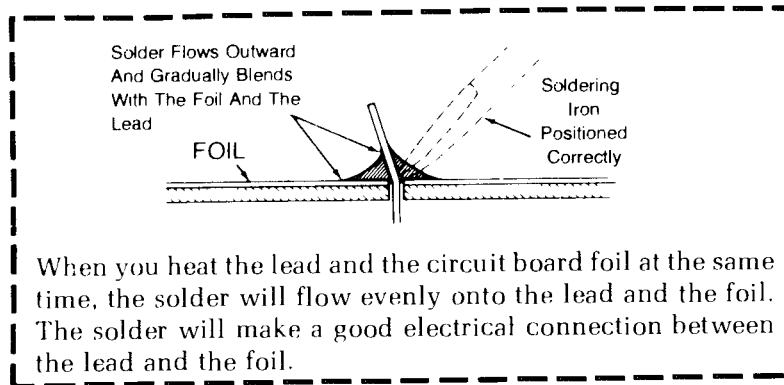

### POOR SOLDER CONNECTIONS

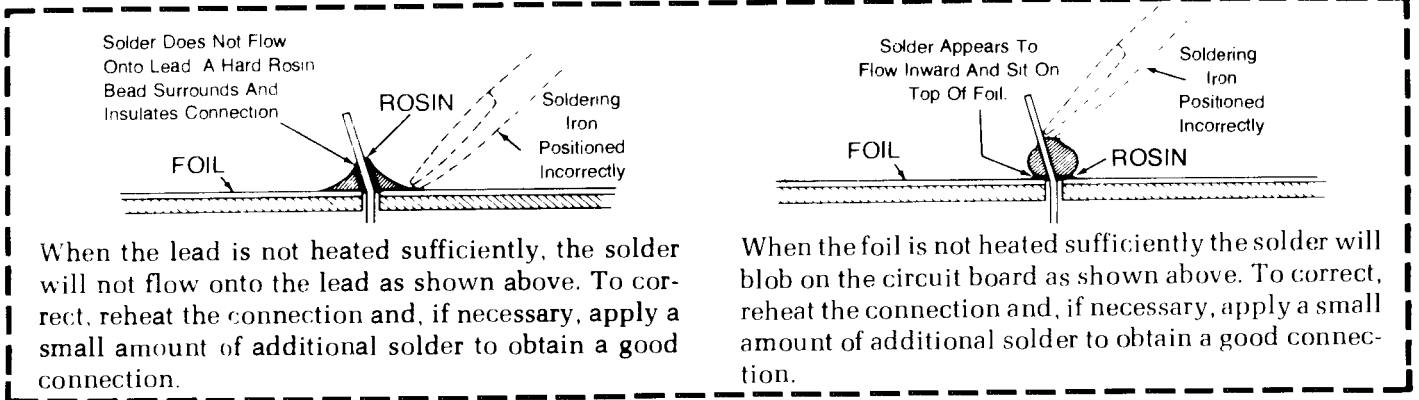

### SOLDER BRIDGES

A solder bridge between two adjacent foils is shown in photograph A. Photograph B shows how the connection should appear. A solder bridge may occur if you accidentally touch an adjacent previously soldered connection, if you use too much solder, or if you "drag" the soldering iron across other foils as you remove it from the connection. A good rule to follow is: always take a good look at the foil area around each lead before you solder it. Then, when you solder the connection, make sure the solder remains in this area and does not bridge to another foil. This is especially important when the foils are small and close together. NOTE: It is alright for solder to bridge two connections on the same foil.

Use only enough solder to make a good connection, and lift the soldering iron straight up from the circuit board. If a solder bridge should develop, turn the circuit board foil-side-down and heat the solder between connections. The excess solder will run onto the tip of the soldering iron, and this will remove the solder bridge. NOTE: The foil side of most circuit boards has a coating on it called "solder resist." This is a protective insulation to help prevent solder bridges.

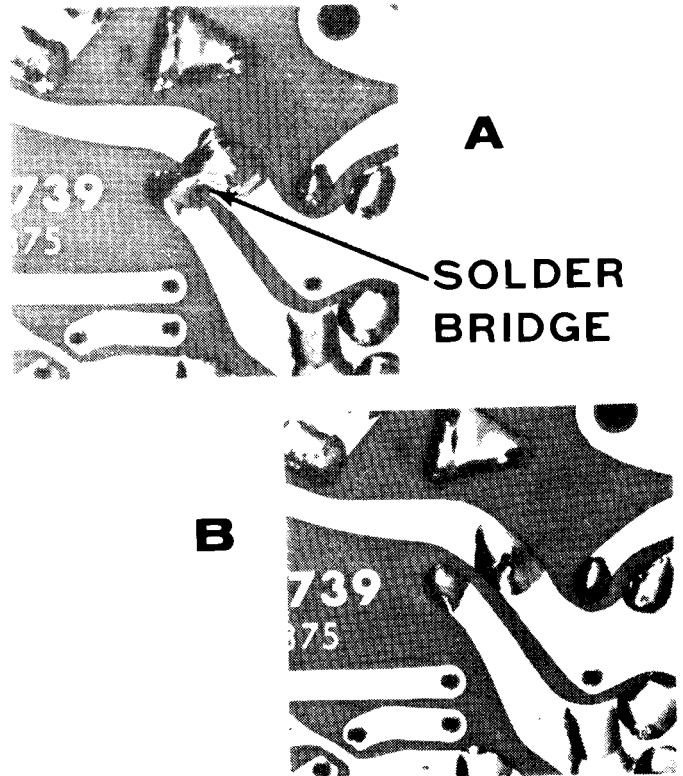



**START**

NOTE: When you install a diode, always match the band on the diode with the band mark on the circuit board. THE CIRCUIT WILL NOT WORK IF THE DIODE IS INSTALLED BACKWARDS.

**IMPORTANT: THE BANDED END OF DIODES CAN BE MARKED IN A NUMBER OF WAYS.**

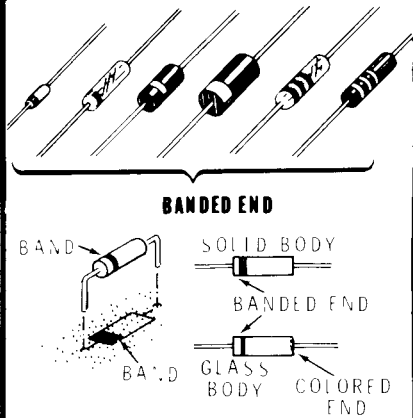

( 4 ) Install diodes (#57-27) at D7, D5, D3, D1, D9, D11, and D13. Make sure all seven cathode banded ends are to the **right**.

( - ) Solder all the leads to the foil and cut off the excess lead lengths.

( - ) Install diodes (#57-27) at D6, D4, D2, D8, D10, D12, and D14 with their cathode ends to the **left**.

( 4 ) Solder all the leads to the foil and cut off the excess lead lengths.

( ) CAREFULLY INSPECT ALL DIODES IN THE PRECEDING STEPS TO BE SURE THEY ARE POSITIONED AS SHOWN IN THE PICTORIAL AND ON THE CIRCUIT BOARD.

**CONTINUE**

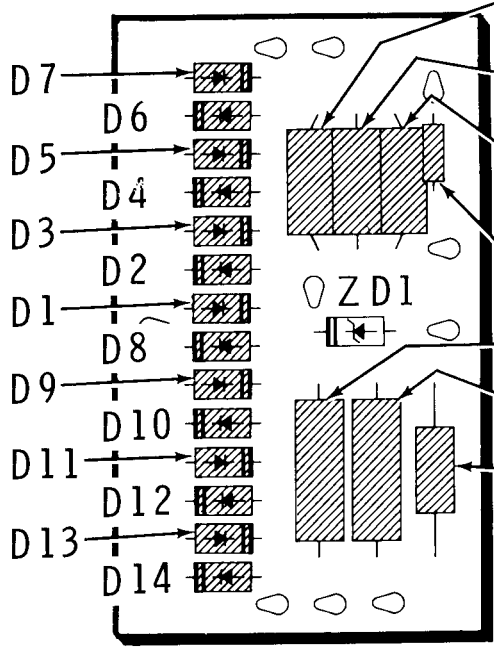

- ( - ) R6: 4.7 MΩ, 1-watt (yellow-violet-green).
  - ( - ) R7: 4.7 MΩ, 1-watt (yellow-violet-green).
  - ( - ) R8: 4.7 MΩ, 1-watt (yellow-violet-green).
  - ( - ) R9: Be sure you installed 5600 Ω (green-blue-red) resistor R9 in Pictorial 1-1, on Page 14.
  - ( - ) R1: 1Ω, 5-watt wire-wound.
  - ( - ) R2: 3600 Ω, 5-watt wire-wound.
  - ( - ) R3: .82 Ω, 2-watt, wire-wound (gray-red-silver-gold).
  - ( - ) Solder the leads to the foil and cut off the excess lead lengths.
- NOTE: No component will be installed directly onto the circuit board at ZD1.

**PICTORIAL 1-2**



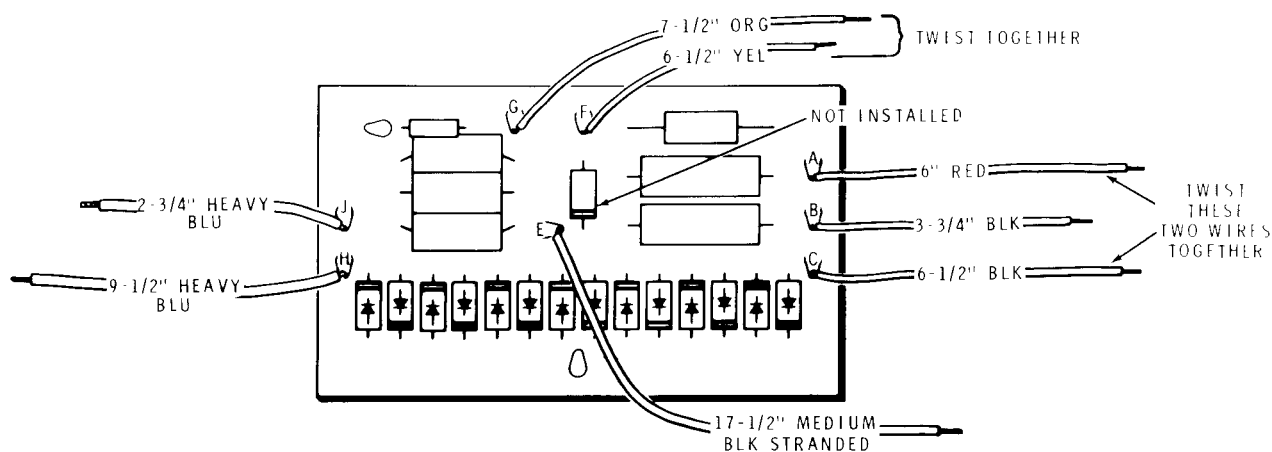

PICTORIAL 1-3

### CIRCUIT BOARD PREWIRING

NOTE: To prepare wires, as in the following step, cut each wire to the length indicated and remove 1/4" of insulation from each end. If the wire is stranded, twist the ends tightly and apply a **small** amount of solder to hold the fine strands together. Unless otherwise stated, "hookup wire" will mean the small solid-conductor wire supplied in various colors.

( ) Prepare the following lengths of hookup wire:

- 6" red
- 6-1/2" black
- 3-3/4" black
- 17-1/2" medium black **stranded** wire
- 7-1/2" orange
- 6-1/2" yellow
- 9-1/2" heavy blue (thick insulation)
- 2-3/4" heavy blue (thick insulation)

Refer to Pictorial 1-3 for the following steps.

From the component side of the circuit board, insert one end of each of the following wires into the designated hole. Solder each wire to the foil side of the board as you install it, then cut off the excess wire ends.

( ) Connect a 6" red hookup wire to circuit board hole A.

( ) Connect a 6-1/2" black hookup wire to circuit board hole C.

( ) Twist together the red and black wires coming from A and C.

( ) Connect a 3-3/4" black hookup wire to circuit board hole B.

( ) Connect a 17-1/2" medium black **stranded** wire to circuit board hole E.

( ) Connect a 7-1/2" orange hookup wire to circuit board hole G.

( ) Connect a 6-1/2" yellow hookup wire to circuit board hole F.

( ) Twist the orange and yellow wires together.

( ) Connect a 9-1/2" heavy blue hookup wire to circuit board hole H.

( ) Connect a 2-3/4" heavy blue hookup wire to circuit board hole J.

( ) Trim all excess wire lengths from the foil side of the circuit board.

( ) Carefully inspect the foil side of the circuit board; all lettered holes except D and K should be soldered. Make sure there are no solder bridges between foils. Also note that one diode is not installed.

This completes the "Circuit Board Prewiring." Set the board aside until it is called for later. Proceed with "Input Coil Assembly."

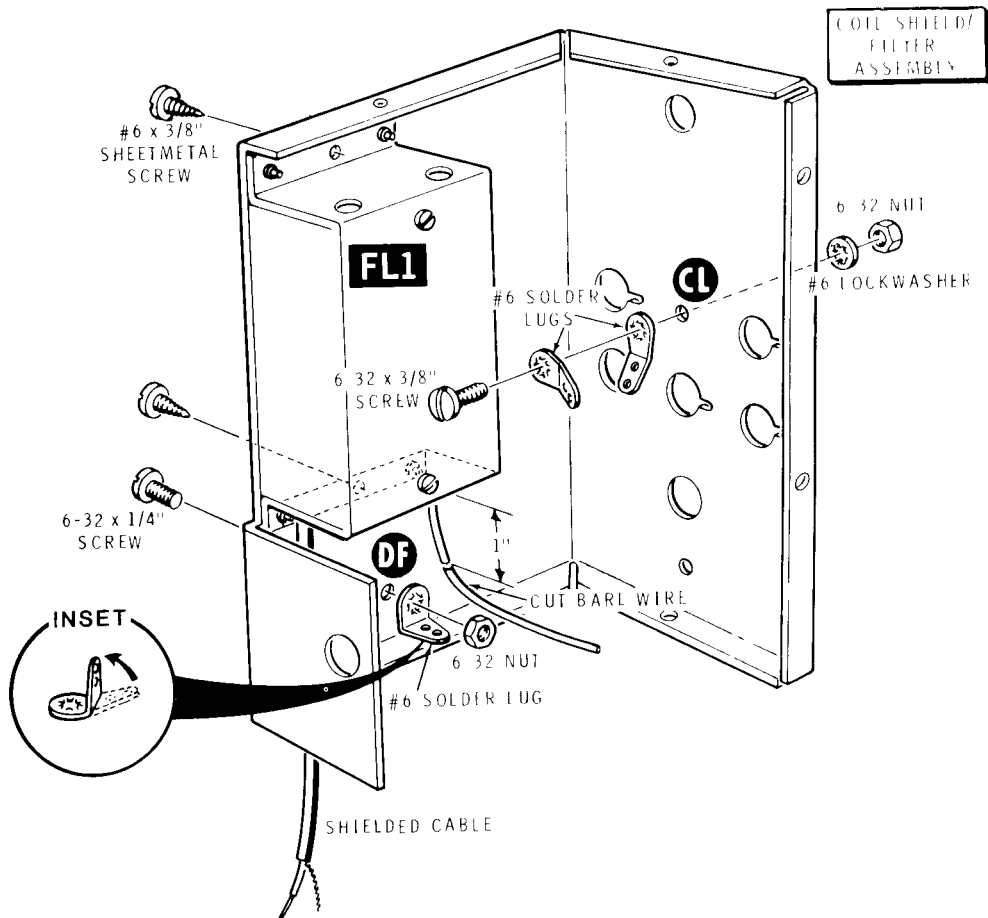

Detail 2-1A

### INPUT COIL ASSEMBLY

Refer to Pictorial 2-1 (Illustration Booklet, Page 4) for the following steps.

Refer to Detail 2-1A for the next four steps.

NOTE: Use the plastic nut starter provided with this kit to hold and start nuts on screws.

- ( ) On the outside of the coil shield/filter assembly, at the top and bottom of filter FL1, install two #6 x 3/8" sheet metal screws as shown in the Detail.
- ( ) Install two #6 solder lugs on the coil shield/filter assembly (#100-1740) at CL with 6-32 x 3/8" hardware. Position the lugs as shown in Detail 2-1B.

- ( ) Install a #6 solder lug at DF with a 6-32 x 1/4" screw and a 6-32 nut. Form the solder lug as shown.

- ( ) At the bottom of filter FL1, cut the bare wire to 1".

Detail 2-1B shows the coil mounting locations for the following steps. Note that the locating lug of each coil must be positioned in the locating slot, and that each coil must be pushed into its mounting hole until the mounting ears snap out to hold the coil in place as shown in Details 2-1C and 2-1D.

- ( ) L1: Refer to Detail 2-1C and install the 20-meter coil (#40-965) at CX.

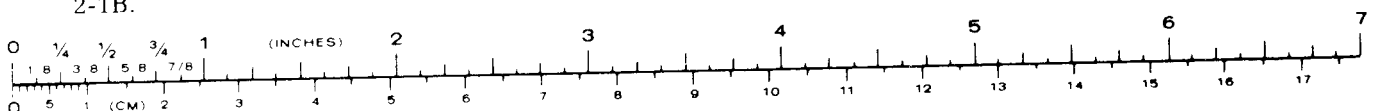

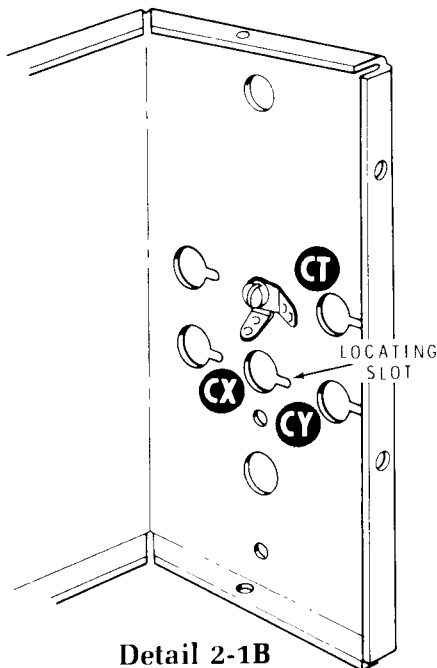

Detail 2-1B

In the same manner:

( · ) L2: Install the 40-meter coil (#40-1963) at CY.

( ) L3: Install the 80-meter coil (#40-1012) at CT.

Refer to Detail 2-1D for the following steps.

NOTE: When you wire capacitors to the three coils in the following steps, position the body of each capacitor against its coil. However, be sure the capacitor leads do not touch the wire of the coil.

Note the positions of lugs 1 and 2 of coil CY as shown in Detail 2-1D.

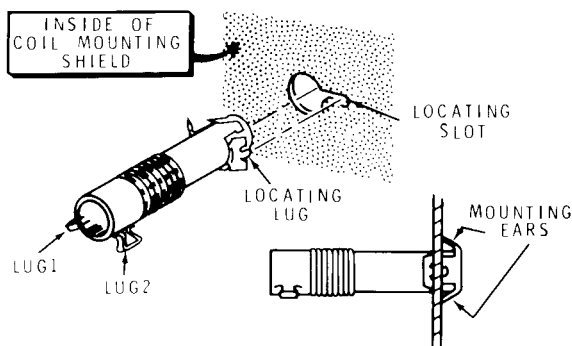

Detail 2-1C

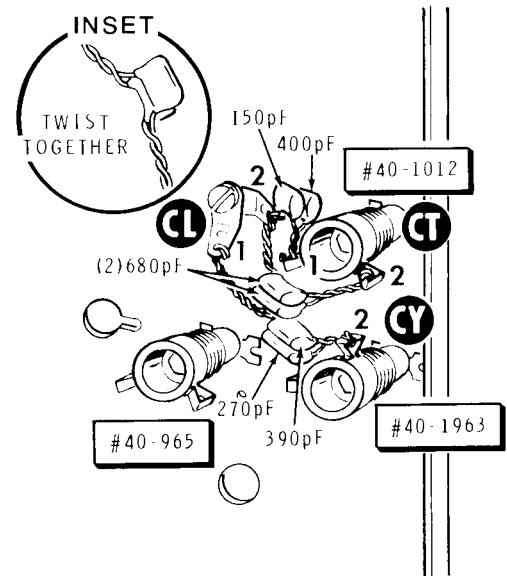

Detail 2-1D

( ) Refer to the inset drawing on Detail 2-1D and twist together the leads of a 270 pF and a 390 pF mica capacitor as shown.

NOTES:

1. In the following steps, each twisted pair of leads will be counted as **two** leads in a solder step.
2. (NS) means not to solder the connection because other wires will be added later. (S-) with a number, such as (S-3), means to solder the connection. The number tells how many wires are in the connection.

( - ) C35, C36: Connect one pair of leads to coil CY lug 2 (NS) and connect the other pair of leads to ground lug CL 1 (NS).

( ) C39, C41: Twist together the leads of a 150 pF mica and a 400 pF mica capacitor as in a previous step. Connect one pair of leads to coil CT lug 1 (NS) and the other pair of leads to ground lug CL2 (NS). Position the capacitors as shown.

( · ) C37, C38: Twist the leads of two 680 pF mica capacitors together as in a previous step. Connect one pair of leads to coil CT lug 2 (NS) and the other pair of leads to ground lug CL2 (S-4). Position the capacitors as shown.

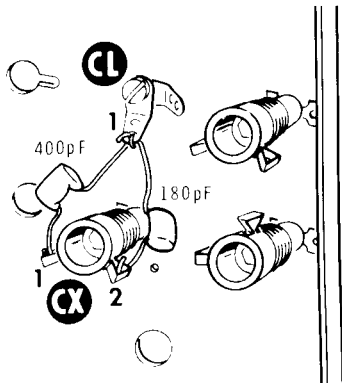

**Detail 2-1E**

Refer to Detail 2-1E for the following steps.

- ( ) C34: Connect a 400 pF mica capacitor from coil CX lug 1 (NS) to ground lug CL-1 (NS).
- ( ) C33: Connect a 180 pF mica capacitor from coil CX lug 2 (NS) to ground lug CL-1 (S-4).

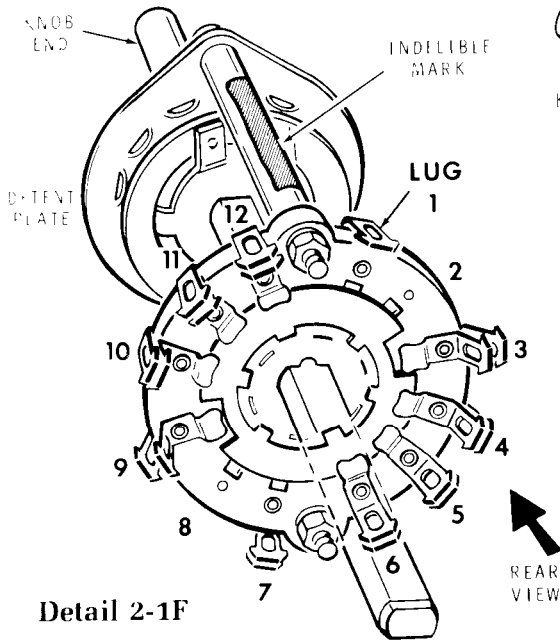

**Detail 2-1F**

Refer to Detail 2-1F for the next four steps.

- ( ) 1. Locate the 4-position rotary switch (#63-1338).

**NOTE:** The switch **detent plate** may be different than those illustrated in these drawings.

- ( ) 2. As viewed from the **knob** end, turn the switch shaft fully clockwise.
- ( ) 3. Position the switch as shown. Note that the switch wafer is symmetrical. Mark the top switch spacer with an indelible pencil, pen, or other marker.
- ( ) 4. **IMPORTANT:** From the marked **top** switch spacer, as viewed from the rear, the **top lug** immediately clockwise from the marked spacer as shown is **switch CZ lug 1**. All switch **spaces** are numbered clockwise as indicated, even when there is no lug at a given location.

Refer to Detail 2-1G for the next nine steps.

- ( ) 1. Position the 4-position rotary switch (#63-1338) on your work area as shown.

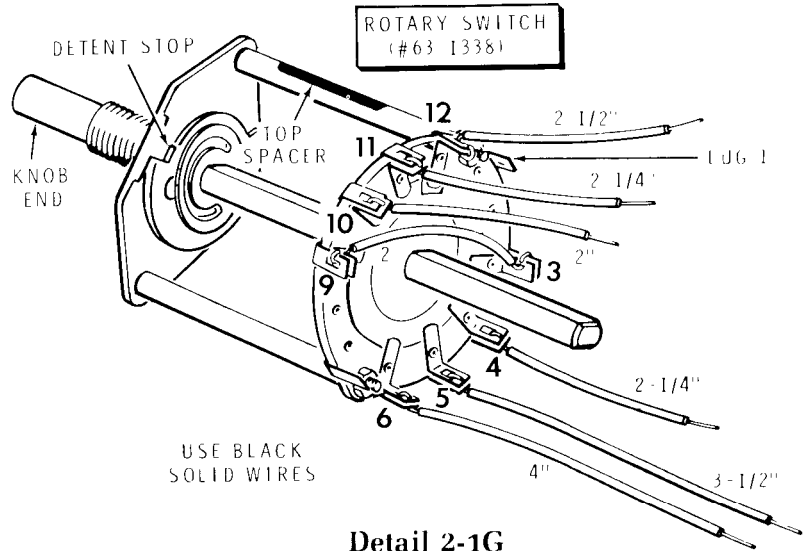

**Detail 2-1G**

- ( ) 2. Prepare the following black hookup (solid) wires:

- 2"                      2-1/2"
- 2-1/4"                2-1/4"
- 3-1/2"                2"
- 4"

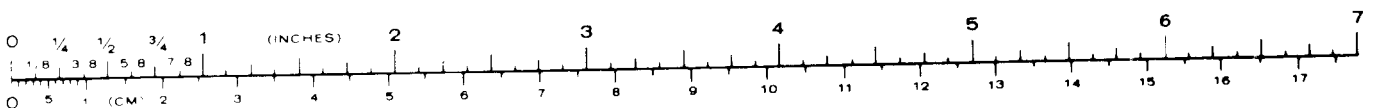



COIL SHIELD/  
FILTER  
ASSEMBLY

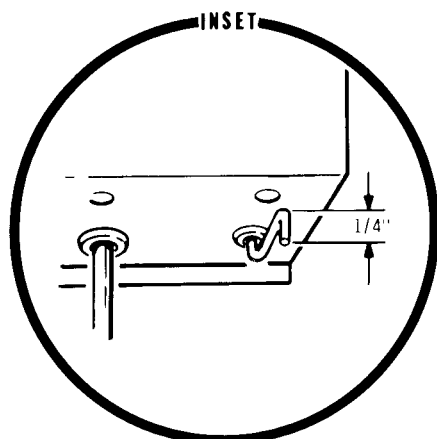

Detail 2-1H

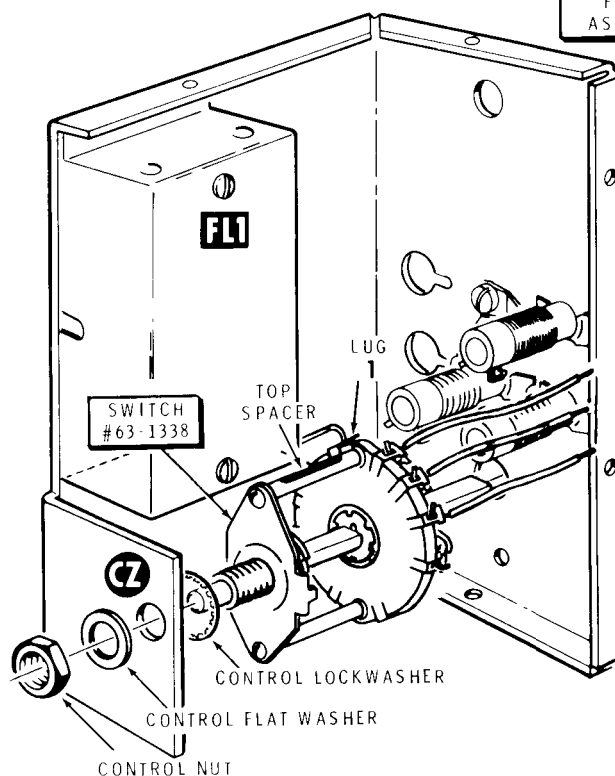

NOTES:

1. When a wire passes through a connection and then goes to another point, it will count as two wires in the solder instructions, one entering and one leaving the connection. Thus, when a wire passes through one switch lug and then goes on to another switch lug at the same position, it will count as **three** wires (S-3) in the solder instructions.
2. When you connect wires to the 4-position rotary switch, be sure to wrap the wire end around **both** switch lugs before you solder the connection. The free wire ends will be connected later.

Connect the prepared wires to the rotary switch as follows:

- ( ) 3. Connect a 2" black wire between switch lugs 3 (S-3) and 9 (S-3). Be sure to position the wire clear of the switch shaft.
- ( ) 4. Connect a 2-1/4" black wire to switch lug 4 (S-3).
- ( ) 5. Connect a 3-1/2" black wire to switch lug 5 (S-3).
- ( ) 6. Connect a 4" black wire to switch lug 6 (S-3).
- ( ) 7. Connect a 2-1/2" black wire to switch lug 12 (S-3).
- ( ) 8. Connect a 2-1/4" black wire to switch lug 11 (S-3).
- ( ) 9. Connect a 2" black wire to switch lug 10 (S-3).
- ( ) Refer to the inset drawing on Detail 2-1H and, on the bottom of filter FL1, bend the 1" bare wire straight out toward the switch (which is to be installed next). Then bend the tip of the wire, 1/4" from its end, sharply downward.
- ( ) SW4: Refer to Detail 2-1H and mount the 4-position rotary switch on the coil/filter shield at CZ. Use a control lockwasher, a control flat washer, and a control nut. Be sure the two switch spacers are aligned vertically and that the **marked top** spacer is positioned as shown. Tighten the hardware only finger tight.
- ( - ) Work the end of the bare wire coming from the bottom of filter FL1 down and into switch CZ lug 1 (NS). Make sure lug 1 does not bend over and short to the switch spacer nut.

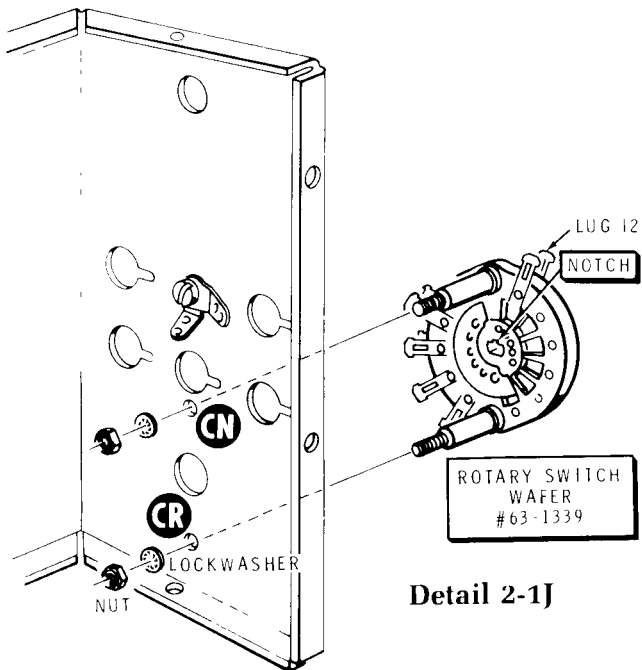

**Detail 2-1J**

- ( . ) Refer to Detail 2-1J and remove the two nuts from the screws passing through the two spacers of the separate rotary switch wafer (#63-1339). Retain the spacers on the screws.
- ( ) SW4B: Insert the bared screw ends into holes CN and CR of the coil shield with lug 12 positioned as shown. Secure the switch with two #6 lockwashers and with the two nuts previously removed.
- ( ) Position the rotating portion of the switch wafer as shown so the notch points between switch lugs 1 and 12. The phenolic shaft (#453-135) may be used to turn the switch rotor.
- ( . ) Check to be sure that switch CZ is still turned fully clockwise (viewed from the shaft end).

Refer to Detail 2-1K for the following steps.

- ( ) Start two 6-32 x 3/16" screws into the tapped holes of the shaft coupler (#456-16). Then slide half the length of the shaft coupler onto the shaft of switch CZ and tighten one screw. The screws should be at the six o'clock position (viewed from the shaft end).
- ( ) Slide the phenolic shaft (#453-135) through the switch wafer on the rear of the coil shield, through hole CP in the shield, and into the shaft coupler. Tighten the remaining setscrew in the shaft coupler onto the phenolic shaft.

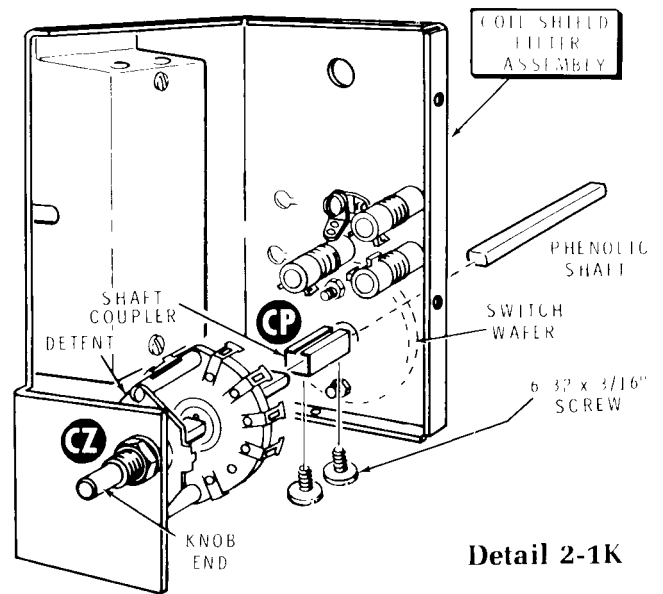

**Detail 2-1K**

- ( . ) Hold the 4-position rotary switch detent (at CZ) stationary and turn the shaft coupler fully counterclockwise, as viewed from the knob end.

Refer to Pictorial 2-1 and Detail 2-1K and Detail 2-1L for the next three steps.

- ( - ) Note the metal rotor of switch wafer CP. Turn the switch detent at CZ slightly so the metal rotor of switch wafer CP makes equal contact on lugs 6 and 12 as shown. Then tighten the mounting hardware on switch CZ.
- ( ) Refer to Detail 2-1L and check the metal rotor of switch wafer CP again. If the metal rotor extends past lug 6, arcing can occur between the rotor and lug 5.
- ( ) Turn the switch shaft through each of its four positions and check the metal rotor to make sure it makes contact with each lug in turn.

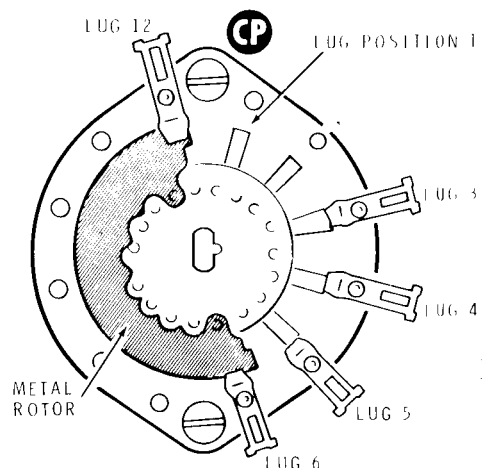

**Detail 2-1L**

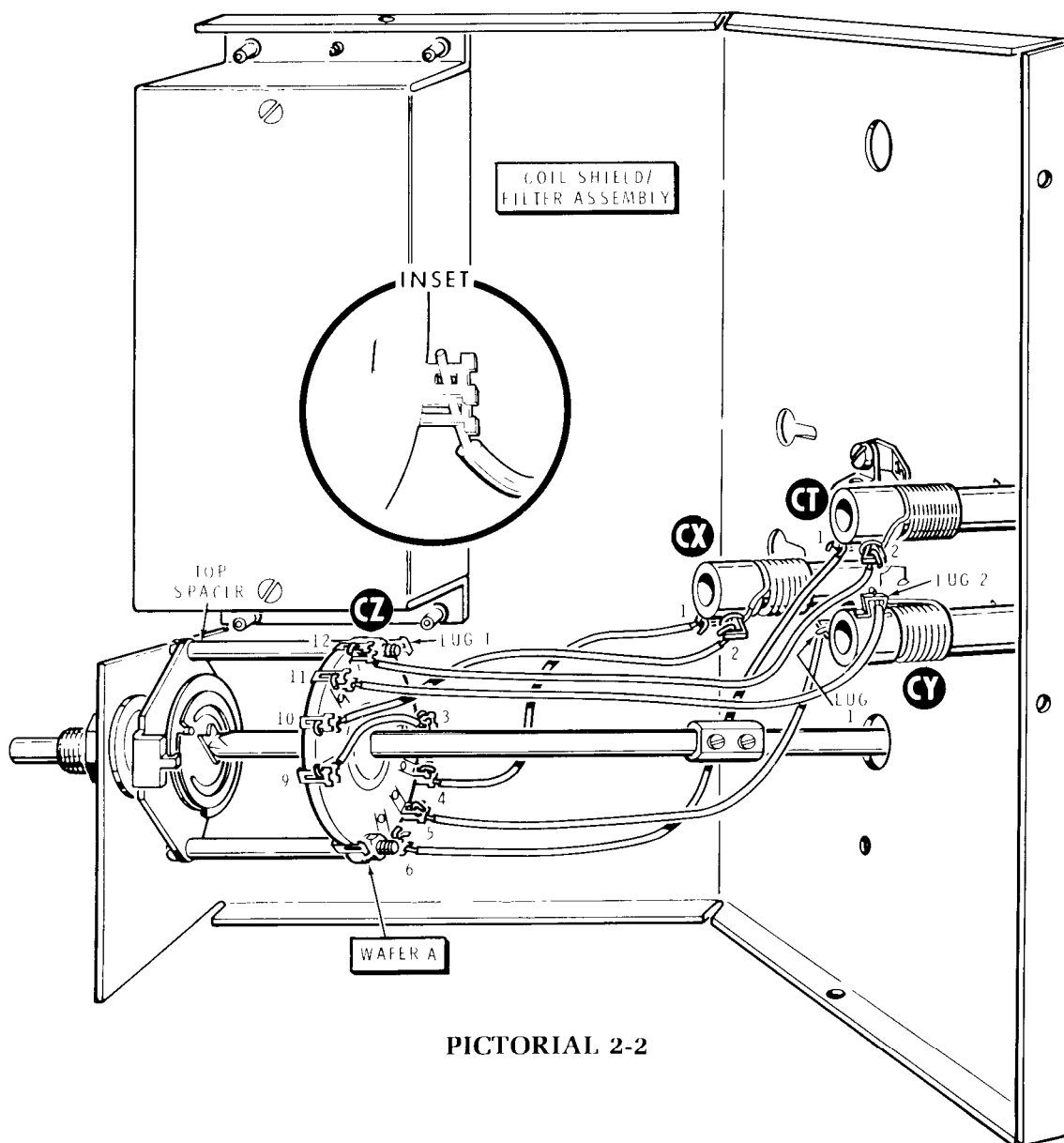

PICTORIAL 2-2

Refer to Pictorial 2-2 for the following steps.

Route and connect the prepared hookup wires coming from switch CZ as follows:

Wire Length	Coming From Switch CZ Wafer A	Connect To	Wire Length	Coming From Switch CZ Wafer A	Connect To
( ) 2-1.4"	Lug 4	Coil CX Lug 1 (S-2)	( ) 4"	Lug 6	Coil CT Lug 1 (S-3)
( ) 3-1.2"	Lug 5	Coil CY Lug 1 (S-1)	( ) 2-1/2"	Lug 12	Coil CT Lug 2 (S-3)
			( ) 2-1/4"	Lug 11	Coil CY Lug 2 (S-3)
			( ) 2"	Lug 10	Coil CX Lug 2 (S-2)



**PART A**

TAKING CARE NOT TO CUT THE OUTER SHIELD OF VERY THIN WIRES. REMOVE THE OUTER INSULATION.



PUSH BACK THE SHIELD. THEN MAKE AN OPENING IN THE SHIELD AND BEND OVER AS SHOWN. PICK OUT THE INNER LEAD.

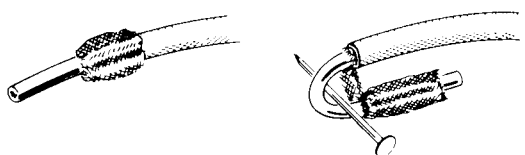

REMOVE THE INNER INSULATION AND STRETCH OUT THE SHIELD. APPLY A SMALL AMOUNT OF SOLDER TO THE END OF THE SHIELD AND THE INNER LEAD. USE ONLY ENOUGH HEAT FOR THE SOLDER TO FLOW.

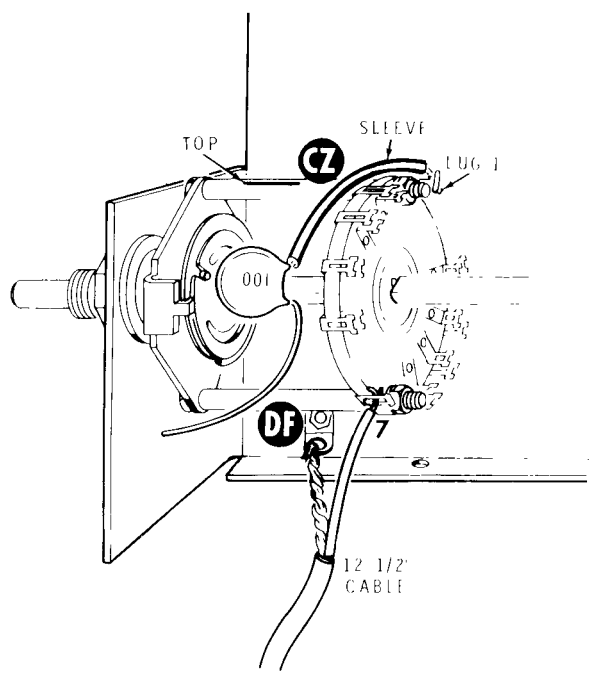
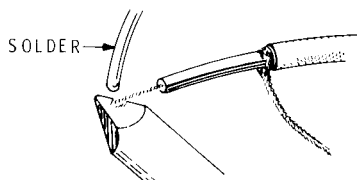

**PICTORIAL 2-4**

**PART B**

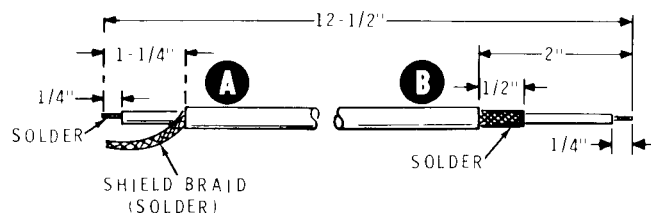

**PICTORIAL 2-3**

**NOTE:** When you prepare the coaxial cable in the following step, refer to Part A of Pictorial 2-4 for the method of removing the inside of the cable from the shield braid. Be careful not to melt the inner insulation.

- ( - ) Prepare a 12-1/2" length of RG-58A/U coaxial cable as shown in Pictorial 2-3, Part B. **At end A**, twist the inner lead wires together and apply a **small** amount of solder to each end to hold the fine strands together. In a like manner, twist and solder the end of the shield braid. **At end B** cut the braid to 1/2", smooth the braid down over the inner insulation, and then add solder to the braid.

- ( - ) Refer to Pictorial 2-4 and connect end A inner lead of the 12-1/2" coaxial cable to switch CZ, wafer A lug 7 (S-1). Connect the shield braid to solder lug DF (S-1). The free end of the cable will be connected later.
- ( - ) Cut a 3/4" piece of small black sleeving. Use this sleeving in the next step.
- ( - ) C47: Cut each lead of a 500 volt (small) .001  $\mu$ F ceramic capacitor to a length of 1". Place the 3/4" sleeving on one lead of the capacitor; then connect this lead of the capacitor to switch CZ, wafer A lug 1 (S-2). The other lead will be connected later.
- ( - ) Turn the switch shaft to its stop in each direction and make sure that no wires interfere with the coupling.

This completes the "Input Coil Assembly."

Set the input coil assembly aside until it is called for later.

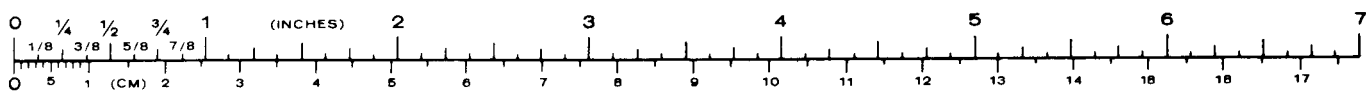



### FRONT PANEL

NOTE: To avoid scratching the front panel and meter faces during the following steps, place a soft cloth on your work table.

Refer to Pictorial 3-1 (Illustration Booklet, Page 4) for the following steps.

- ( ) Refer to Detail 3-1A and install the Heathkit nameplate in the two holes marked ED. Use the two push-on nuts.

NOTE: Before mounting the terminal strip in the following step, scrape away any paint around hole EB which would prevent the lockwasher and terminal strip foot from making good contact with the panel.

- ( ) M1: Refer to Detail 3-1B and install the plate meter (#407-145) at EA. Use the hardware supplied with the meter. Install a 3-lug terminal strip at EB. Use #6 lockwashers at EB. CAUTION: Do not overtighten the meter hardware as the meter case can be damaged.

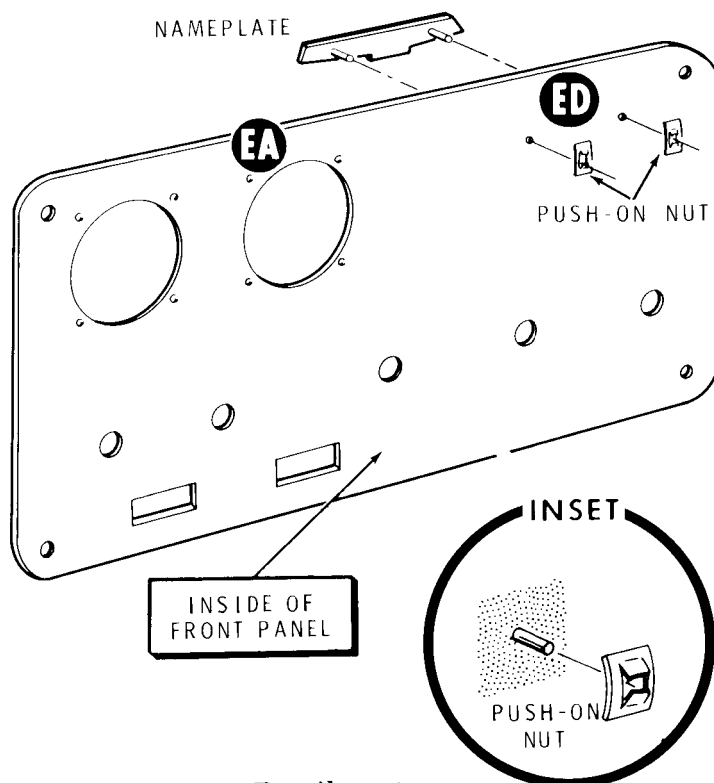

Detail 3-1A

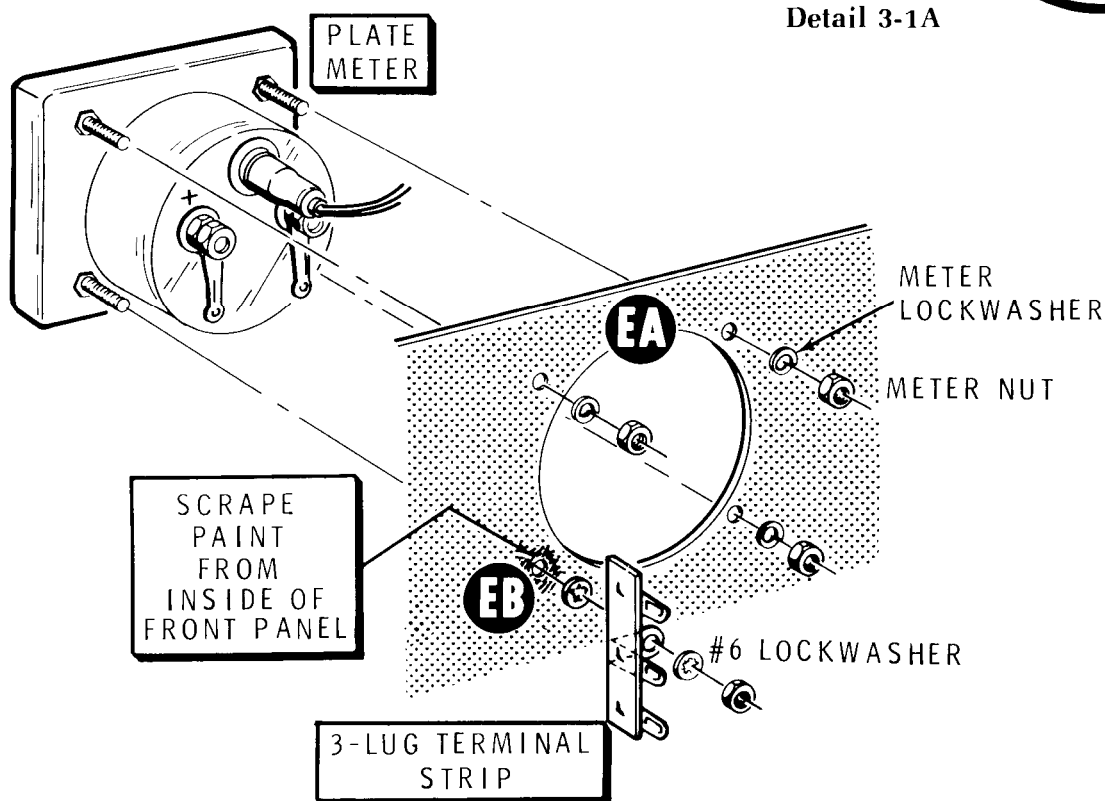

Detail 3-1B

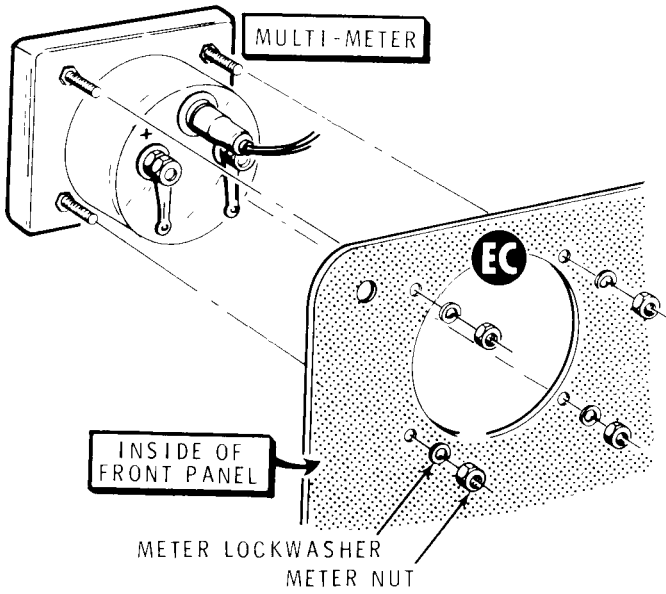

**Detail 3-1C**

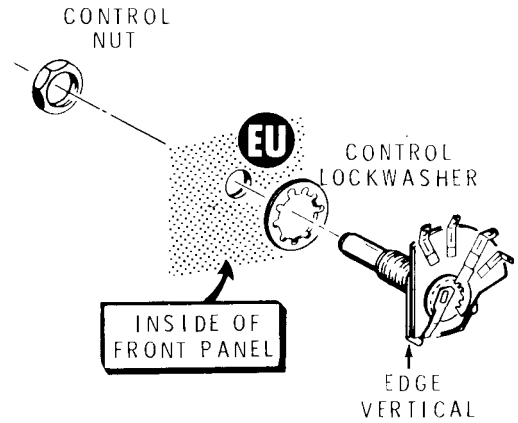

**Detail 3-1D**

- ( ) M2: Refer to Detail 3-1C and install the multi-meter (#407-146) at EC. Use the hardware supplied with the meter.
- ( ) Remove and discard the wire jumpers between the meter terminals on each meter.
- ( ) SW3: Refer to Detail 3-1D and install the 3-position rotary switch (#63-47) at EU. Use a control lockwasher, and a control nut. Position the switch lugs as shown in the Pictorial.
- ( ) Refer to the inset drawing on Detail 3-1E and cut and form a control solder lug as shown. Cut the lug portion to 3/4" and bend it to fit the lug on R26 as indicated in the following step.
- ( ) R26: Refer to Detail 3-1E and install the 100 kΩ control (#10-12) at ET. Use a control solder lug, a control flat washer, and a control nut. Align the control solder lug with lug 1 of the control. Solder the two lugs together.

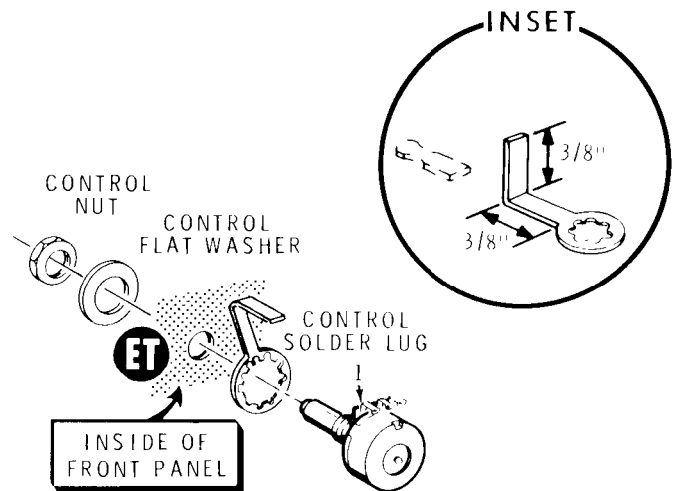

**Detail 3-1E**

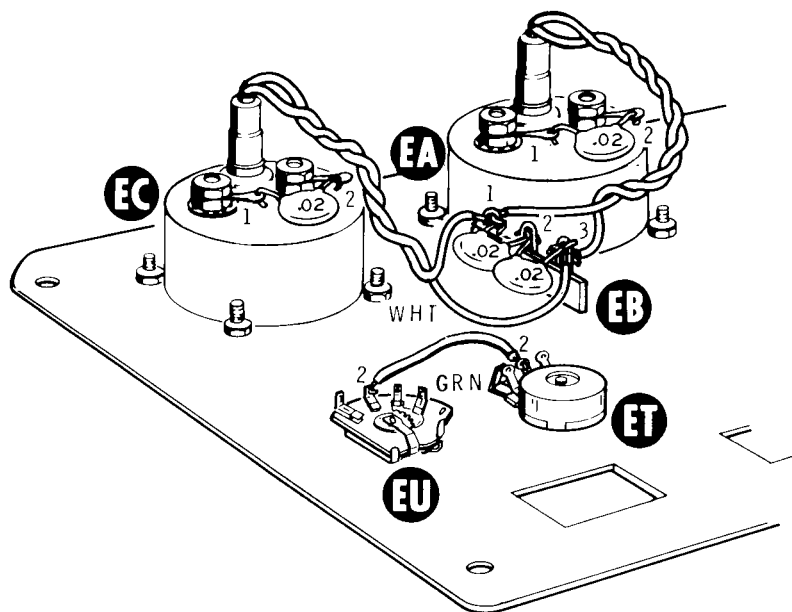

PICTORIAL 3-2

Refer to Pictorial 3-2 for the following steps.

- ( ) Bend all four EA and EC meter lugs outward approximately 45 degrees.
- ( ) C8: Connect a  $.02 \mu\text{F}$  ceramic capacitor between meter EC lugs 1 (NS) and 2 (NS).
- ( ) C3: Connect a  $.02 \mu\text{F}$  ceramic capacitor between meter EA lugs 1 (NS) and 2 (NS).
- ( ) Cut the leads of two  $.02 \mu\text{F}$  ceramic capacitors to a length of  $1/2''$ . These capacitors will be used in the next two steps.
- ( ) C24: Install a  $.02 \mu\text{F}$  ceramic capacitor between terminal strip EB lugs 1 (NS) and 2 (NS).
- ( ) C25: Install a  $.02 \mu\text{F}$  ceramic capacitor between terminal strip EB lugs 2 (S-2) and 3 (NS).
- ( ) Cut the black pilot lamp lead from meter EC to  $4''$  and the white lead to  $4-1/2''$ . Prepare both wire ends. Twist the two leads together.
- ( ) Connect the black pilot lamp lead coming from meter EC to terminal strip EB lug 1 (NS).
- ( ) Connect the white pilot lamp lead coming from meter EC to terminal strip EB lug 3 (NS).
- ( ) Cut the black pilot lamp lead coming from meter EA to  $3-1/2''$  and the white lead to  $4-1/2''$ . Prepare the wire ends. Twist the two leads together.
- ( ) Connect the black pilot lamp lead coming from meter EA to terminal strip EB lug 1 (NS).
- ( ) Connect the white pilot lamp lead coming from meter EA to terminal strip EB lug 3 (NS).
- ( ) Prepare a  $3-1/2''$  green wire.
- ( ) Connect the  $3-1/2''$  green wire from rotary switch EU lug 2 (S-1) to control ET lug 2 (S-1).

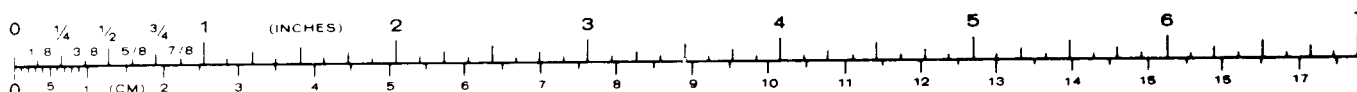

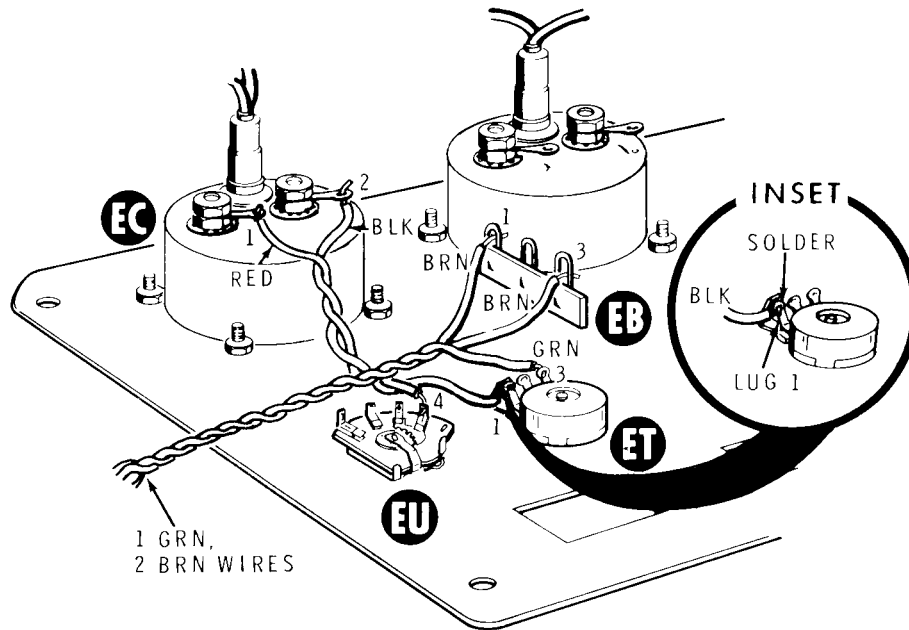

PICTORIAL 3-3

( ) Prepare the following lengths of hookup (solid) wire:

- 3-1/2" black      18" brown
- 3-1/2" red        18" brown
- 32" green

Refer to Pictorial 3-3 for the following steps.

- ( ) Twist together the 3-1/2" black and the 3-1/2" red wires.
- ( ) Connect one end of the 3-1/2" black wire to control ET lug 1 (S-1). Connect the other end of this black wire to meter EC lug 2 (S-2).
- ( ) Connect the 3-1/2" red wire from meter EC lug 1 (marked + on the case) (S-2) to rotary switch EU lug 4 (S-1).

( ) Starting at one end of each wire, twist together **two** 18" brown wires and a 32" green wire.

At the matched ends of the twisted wires:

- ( ) 1. Connect one 18" brown wire to terminal strip EB lug 3 (S-4).
- ( ) 2. Connect the other 18" brown wire to terminal strip EB lug 1 (S-4).
- ( ) 3. Connect the 32" green wire to lug 3 of control ET (S-1).

The free wire ends will be connected later.

Set the front panel assembly aside until it is required in later steps.

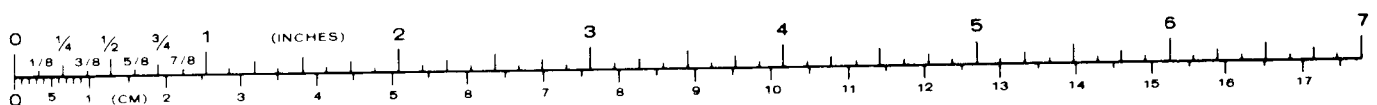



# CHASSIS

## CHASSIS PARTS MOUNTING

Refer to Pictorial 4-1 (Illustration Booklet, Page 5) for the following steps.

- (✓) Install 1/2" rubber grommets at T, AK, and AL.
- (✓) Install a 3/4" rubber grommet at AH.
- (✗) J4: Refer to Detail 4-1A and mount a coaxial jack at A on the rear apron of the chassis. Use 4-40 × 5/16" hardware and #4 lockwashers.
- (✓) J3: In the same manner, mount another coaxial jack at L on the rear apron.
- (✗) J2: Refer to Detail 4-1B and mount a phono socket at U on the rear apron. Use 6-32 × 1/4" hardware. Position the ground lug toward the coaxial jack.
- (✓) J1: In the same manner, mount another phono socket at X.

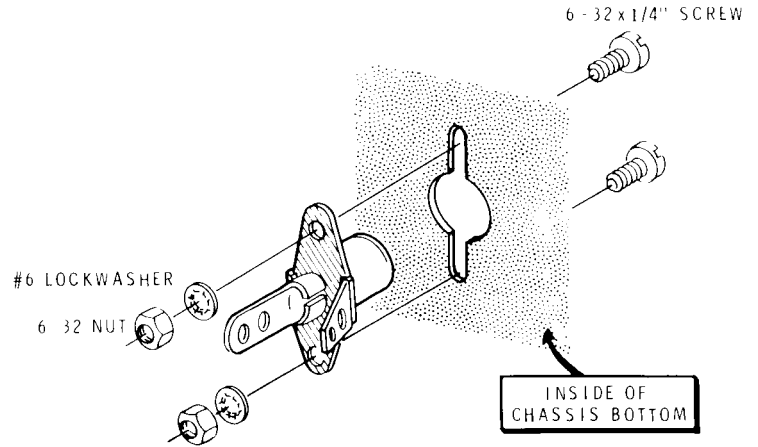

Detail 4-1B

NOTE: In the following steps, the switch mounting holes are off center and fit in one position only.

- (✓) SW1: Refer to Detail 4-1C and mount the DPST rocker switch (#61-14) at Z on the front apron of the chassis. Use 6-32 × 3/8" flat head screws with lockwashers and nuts. Note the position of the lugs in the Pictorial.
- (✓) SW2: Similarly, mount the DPDT rocker switch (#61-15) at AN on the chassis front apron.

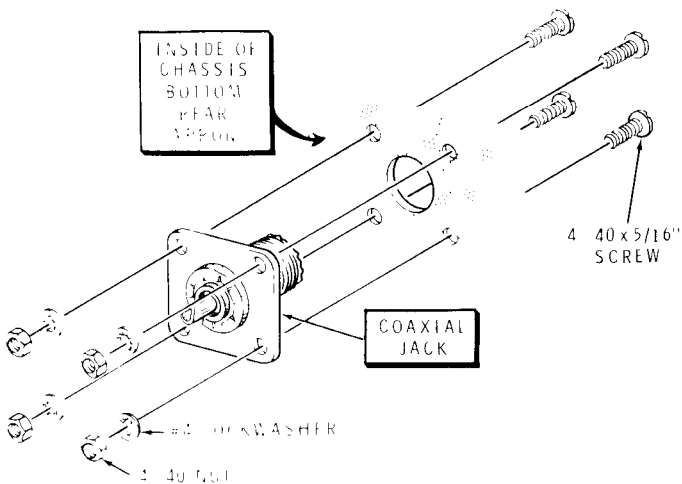

Detail 4-1A

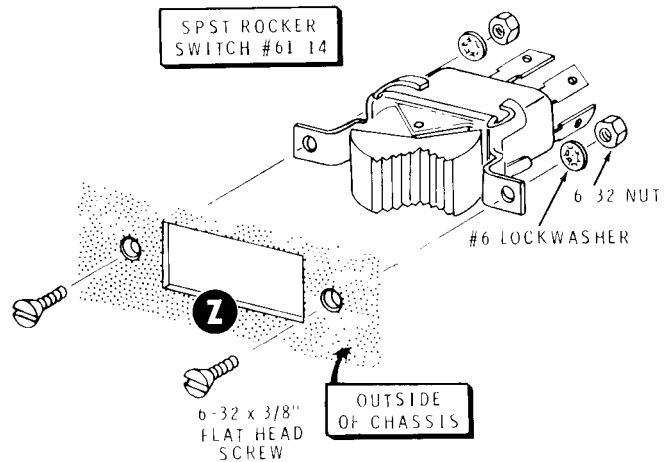

Detail 4-1C

NOTE: Discard any loose metal clips you find in the tube socket boxes.

- (- ) Refer to Detail 4-1D and mount a 5-lug ceramic tube socket at N with a 2-lug terminal strip at AG. Use 6-32  $\times$  11/16" hardware and fiber flat washers. Be sure to properly position socket lug 3 exactly as shown, and to place a lockwasher **under** the terminal strip mounting foot.
- ( ) Similarly, mount a 5-lug ceramic tube socket at D. Use 6-32  $\times$  11/16" hardware and fiber flat washers. Do not use a terminal strip on this socket. Note the position of socket lug 3.
- (- ) Refer to Detail 4-1E and mount two #6 solder lugs at C. Use 6-32  $\times$  1/4" hardware. Be sure to position the lugs as shown in the Pictorial.
- (- ) Similarly, mount two #6 solder lugs at M. Position these lugs as shown in the Pictorial.

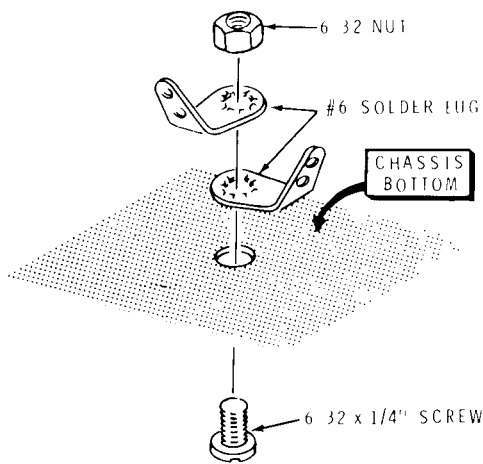

Detail 4-1E

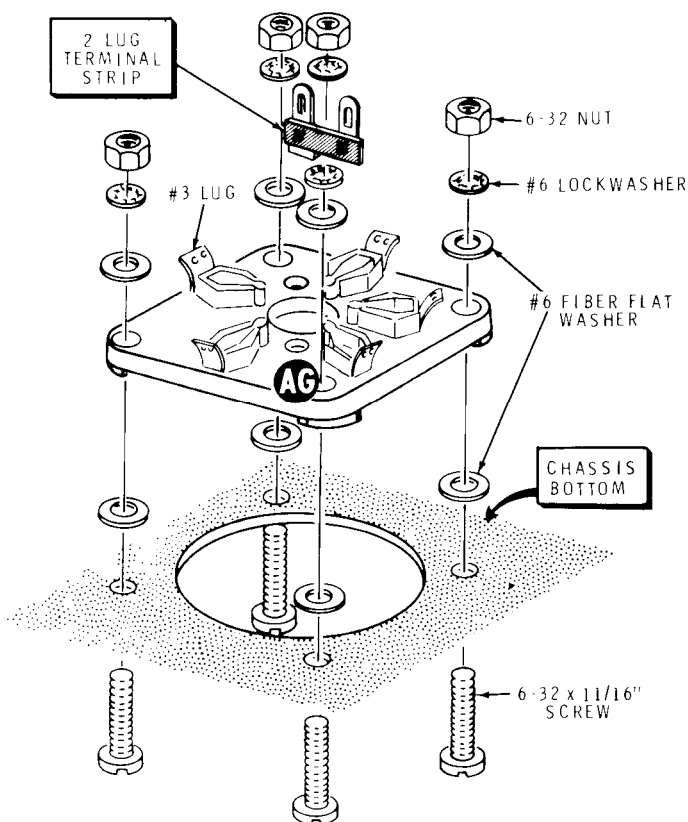

Detail 4-1D

- (- ) Mount one #6 solder lug at AX. Use 6-32  $\times$  3/8" flat head hardware.
- (- ) Refer to Detail 4-1F and mount a 3-lug terminal strip at P. Use 6-32  $\times$  1/4" hardware.

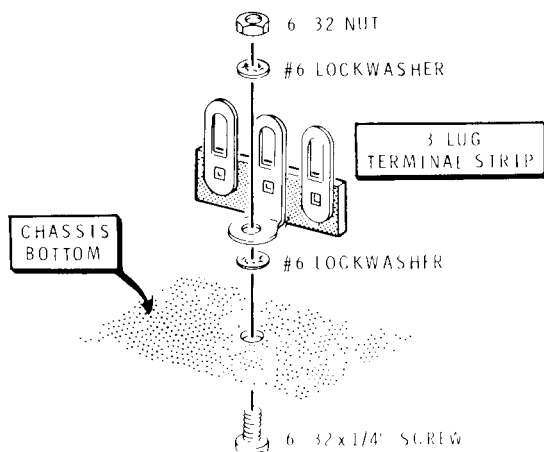

Detail 4-1F

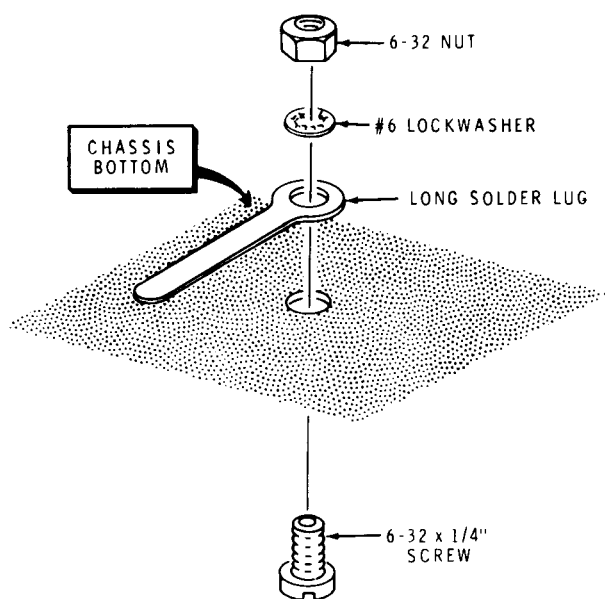

**Detail 4-1G**

- (✓) Refer to Detail 4-1G and mount a long solder lug at R. Use 6-32 × 1/4" hardware.
- (✓) Install a 5/16" rubber grommet at F. NOTE: Grommet F is under the center of relay K1 in Pictorial 4-1.

Refer to Detail 4-1H for the following steps.

- (✓) Position the relay (#69-55) with its lugs to the right as shown. Unsolder and discard the black insulated wire between lug 7 and its movable arm.

NOTE: When you solder the small metal braid in the following steps, use the minimum amount of heat necessary to secure a good connection.

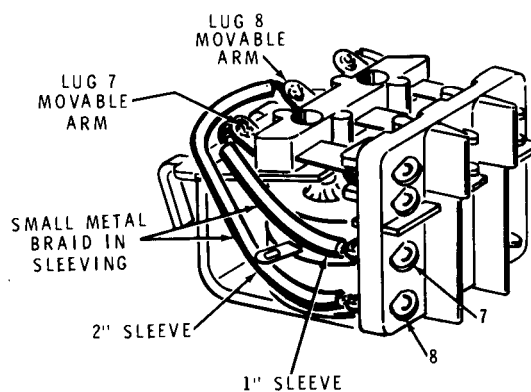

**Detail 4-1H**

**IMPORTANT:** Disregard any lug numbers stamped on the relay; refer to the steps and the illustrations for the correct lug numbers.

- (✓) Replace the wire discarded in the previous step with a 3-1/4" length of untinned braided wire that is folded in the middle and pushed through a 1" length of black sleeving. (See Detail 4-1J.) Solder one end of the braid wires to relay lug 7 and the other end to its movable arm.
- (✓) Unsolder and discard the black insulated wire between lug 8 and its arm.
- (✓) Replace the wire discarded in the previous step with a 5-1/4" length of small metal braid that is folded in the middle and pushed through a 2" length of black sleeving. Solder one end of the braid to lug 8 and the other end to its movable arm.

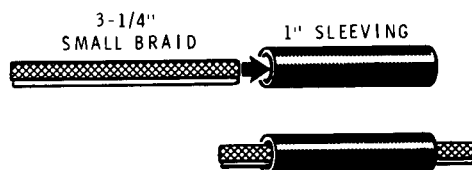

**Detail 4-1J**

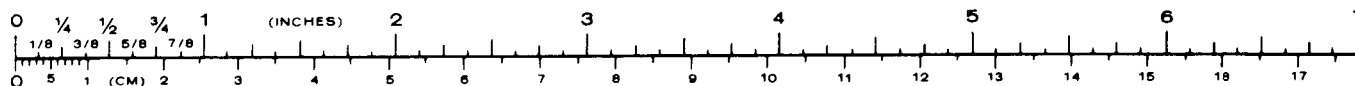



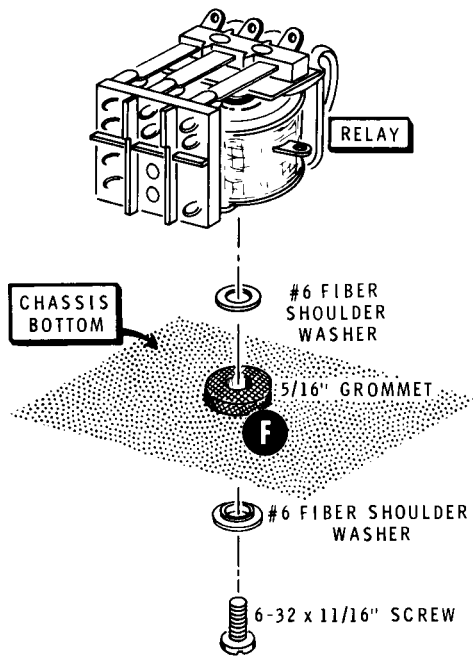

Detail 4-1K

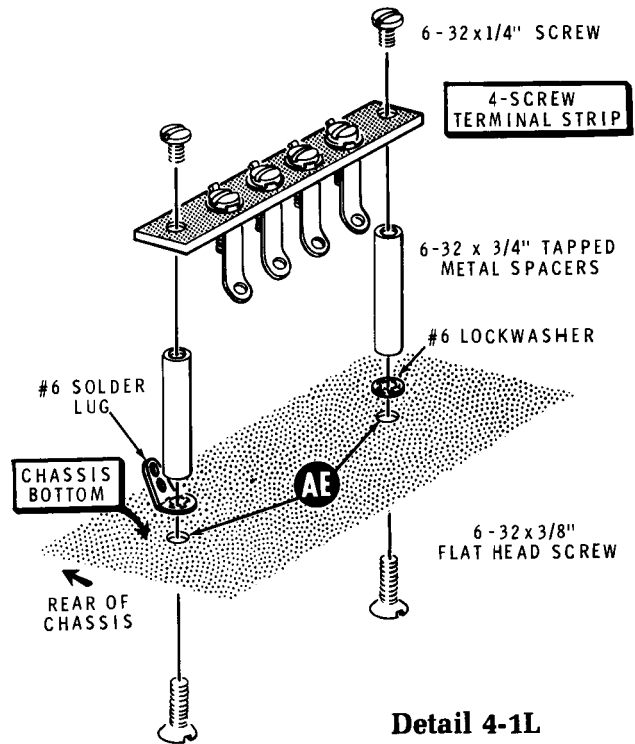

Detail 4-1L

(J) K1: Refer to Detail 4-1K and mount relay K1 (#69-55) through grommet F. Use a 6-32 x 11/16" screw and two #6 fiber shoulder washers. Do not overtighten this screw. The rubber grommet is used to provide resiliency.

(J) Inspect the relay to make sure that neither piece of metal braid can possibly touch the metal frame of the relay.

(J) Refer to Detail 4-1L and mount the 4-screw terminal strip at AE. Use two 6-32 x 3/8" flat head screws, a #6 lockwasher, a #6 solder lug, two 6-32 x 3/4" tapped metal spacers, and two 6-32 x 1/4" screws. Be sure to position the solder lug as shown in the Detail and Pictorial.

(J) Refer to Detail 4-1M and install a socket shell in hole Y. Be sure to install this socket so the beveled corners are positioned away from the nearby edge of the chassis as shown.

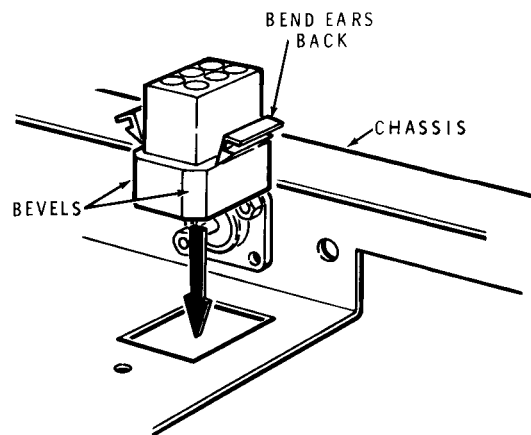

Detail 4-1M



## ALC WIRING

Refer to Pictorial 4-2 (Illustration Booklet, Page 5) for the following steps.

- (✓) Refer to Detail 4-2A and mount a 6-lug terminal strip on the top front of the chassis at holes BE and BF with 6-32 × 1/4" hardware. Use a #6 solder lug at BF only.
- (✓) Refer to Part A of the Pictorial for the next five steps. Note the positions of the components.
- (✓) R23: Connect a 47 kΩ (yellow-violet-orange) resistor between terminal strip BE lugs 2 (NS) and 4 (NS).
- (✓) R21: Connect a 2200 Ω (red-red-red) resistor between terminal strip BE lugs 1 (NS) and 3 (NS).
- (✓) C51: Connect a .02 μF ceramic capacitor from terminal strip BE lug 4 (NS) to solder lug BF (NS).
- (✓) C49: Connect a 500-volt (small) .001 μF ceramic capacitor from terminal strip BE lug 5 (NS) to solder lug BF (NS).
- (✓) C5: Connect a .02 μF ceramic capacitor from terminal strip BE lug 6 (NS) to solder lug BF (S-3).

Refer to Part B of the Pictorial for the next eight steps.

- (✓) Prepare a 10" orange wire and a 17" yellow wire.
- (✓) Connect one end of the 10" orange wire to terminal strip BE lug 6 (NS).
- (✓) Connect one end of the 17" yellow wire to terminal strip BE lug 2 (S-2).
- (✓) Pass the free ends of the yellow and the orange wires down through grommet T. To temporarily secure the ends of these wires, they can be passed up through some other hole in the chassis. The free ends will be connected later.

- (✓) R22: Connect a 2200 Ω (red-red-red) resistor between terminal strip BE lugs 3 (NS) and 5 (S-2).
- (✓) R11: Connect a 27 kΩ (red-violet-orange) resistor between terminal strip BE lugs 3 (NS) and 6 (S-3).
- (✓) D18: Connect the cathode lead (banded end) of a 1N458 diode (#56-24) to terminal strip BE lug 3 (NS) and connect the anode lead to lug 4 (S-3).
- (✓) C48: Connect a 15 pF ceramic capacitor between terminal strip BE lugs 3 (S-5) and 1 (NS).

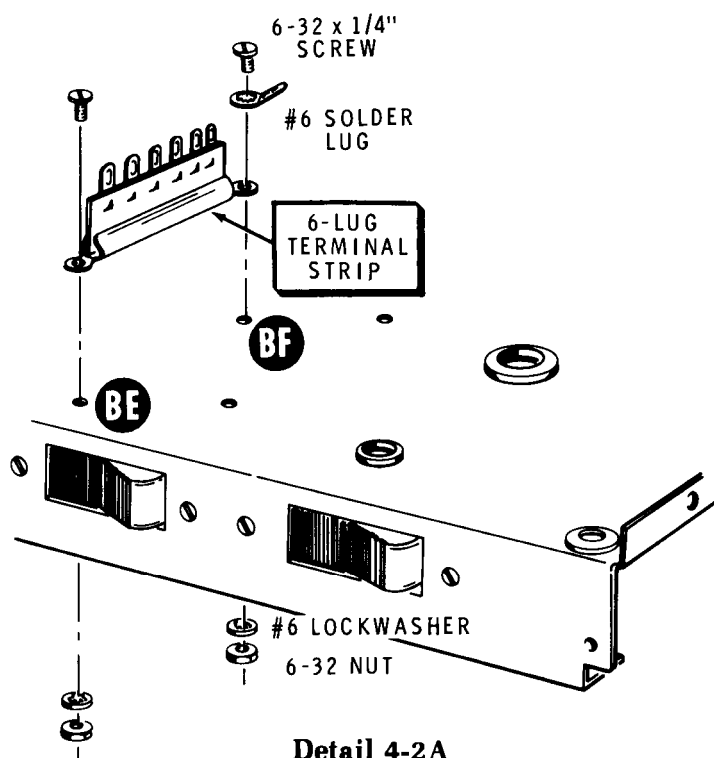

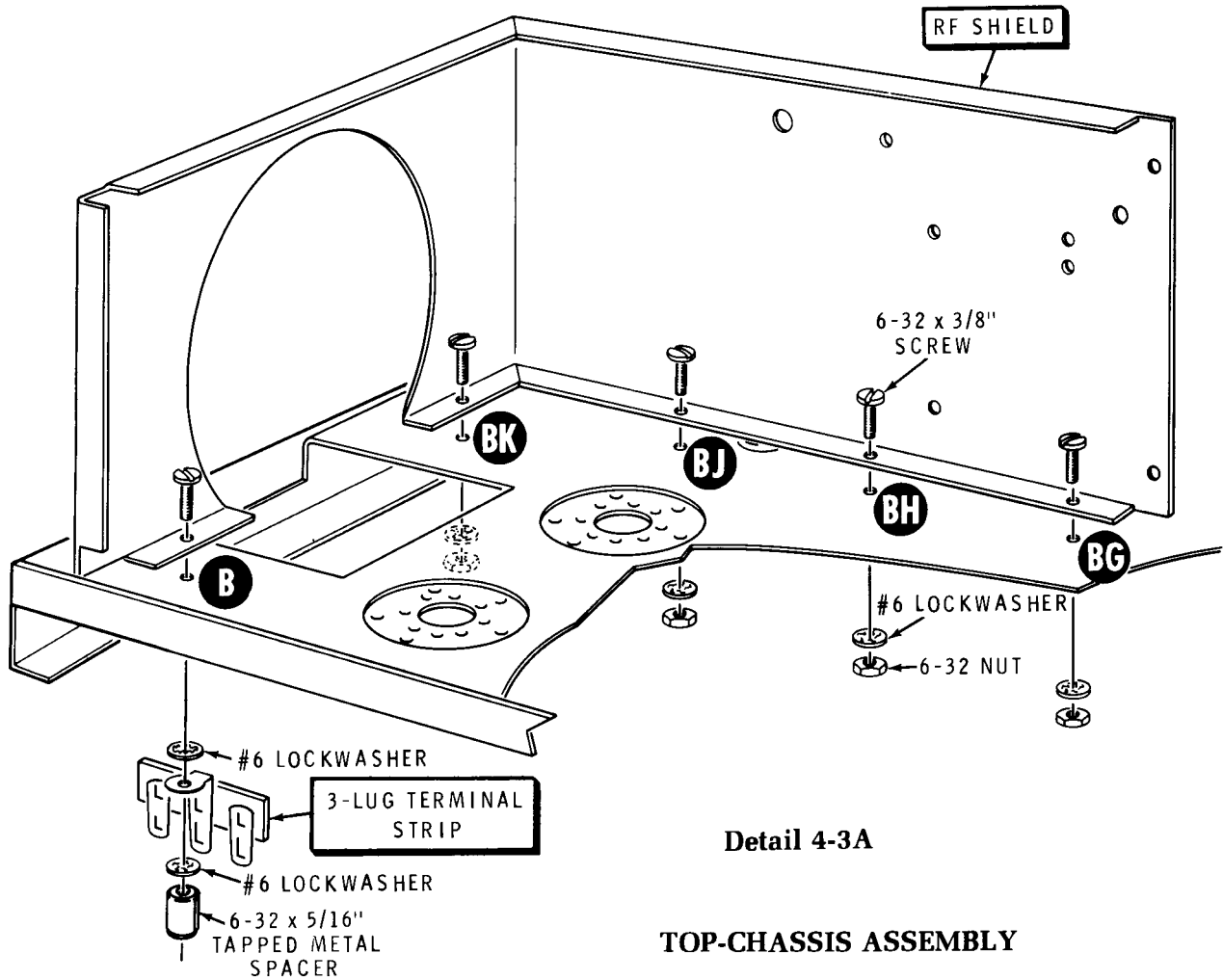

Detail 4-3A

TOP-CHASSIS ASSEMBLY

Refer to Pictorial 4-3 (Illustration Booklet, Page 5) for the following steps.

(✓) Refer to Detail 4-3A and mount the RF shield (#206-493) on the top of the chassis. At BG, BH, BJ, and BK, use 6-32 × 3/8" screws. At #B, use a 6-32 × 3/8" screw with a 3-lug terminal strip, two #6 lockwashers, and a 6-32 × 5/16" tapped metal spacer as shown. NOTE: Use pliers on the spacer to be sure it is tightened securely.

(✓) Refer to Detail 4-3B and mount the brass spring (#258-115) at CD and CE on the RF shield. Use 6-32 × 3/8" flat head hardware with a #6 solder lug at CE. When the hardware is tightened, the end of the brass strip will contact the upper lip of the RF shield.

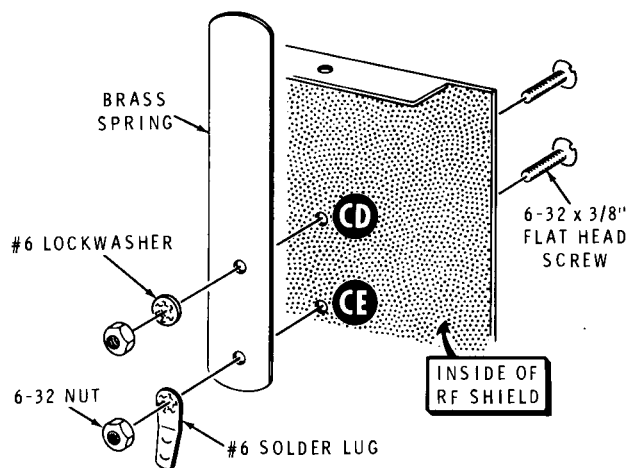

Detail 4-3B

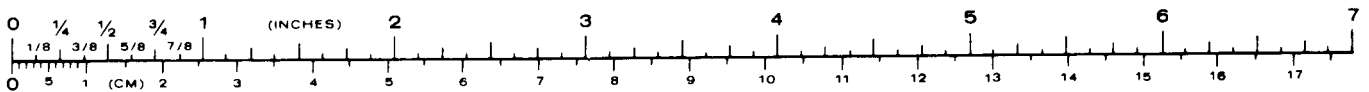

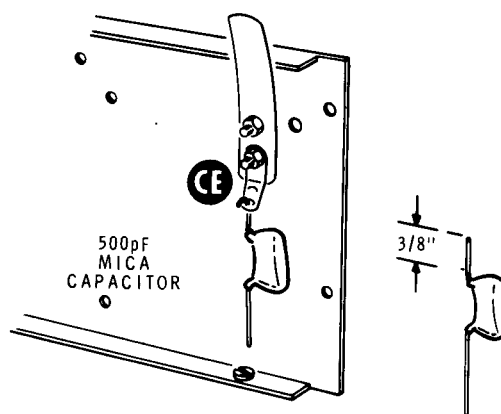
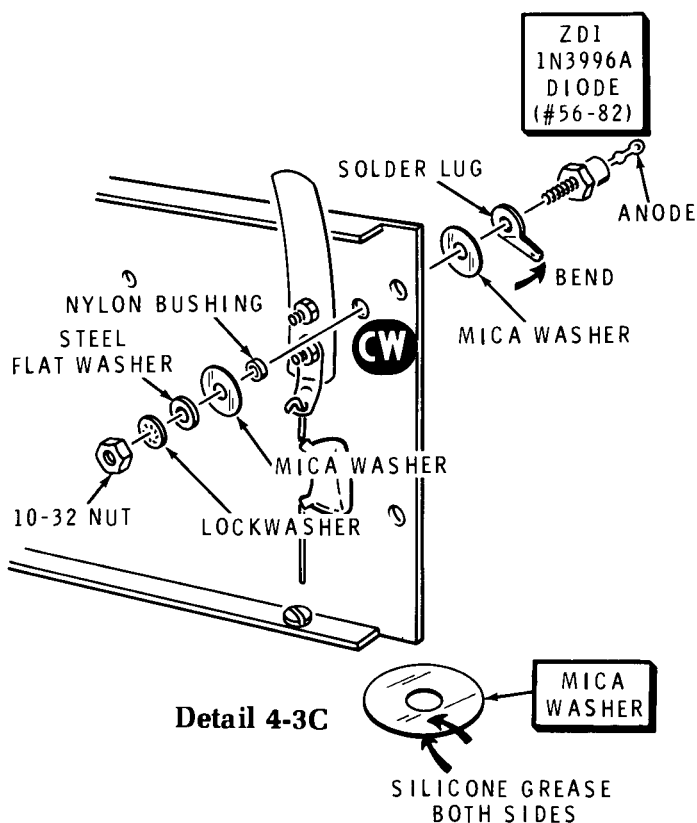

- (✓) C56: Refer to Detail 4-3D and cut one lead of a 500 pF mica capacitor (may be marked ".0005") to a length of 3/8". Connect this lead to the solder lug at CE (S-1). The other lead will be connected later.

- (✓) ZD1: Refer to Detail 4-3C and install the 1N3996A diode (#56-82) at CW on the outside of the RF shield with the mounting stud and nut on the same side of the shield as the brass spring, as shown in the Pictorial. Use the hardware supplied with the diode. Coat both sides of each mica washer with silicone grease before you install it. Make sure the nylon bushing is centered in the hole and that the solder lug points downward. Tighten the nut firmly, but do not overtighten.

- (✓) Bend the end of the diode solder lug up away from the chassis at an angle of approximately 45 degrees.

- (✓) If you have an ohmmeter, measure the resistance from diode ZD1 anode terminal to chassis ground and make sure the diode is not shorted.

- (✓) Prepare two 3" lengths of medium black stranded wire. Refer to Pictorial 4-3 and connect one end of one wire to the diode solder lug at CW (S-1). Connect one end of the other 3" wire to the anode terminal on diode ZD1 (S-1). The other ends of these wires will be connected later.

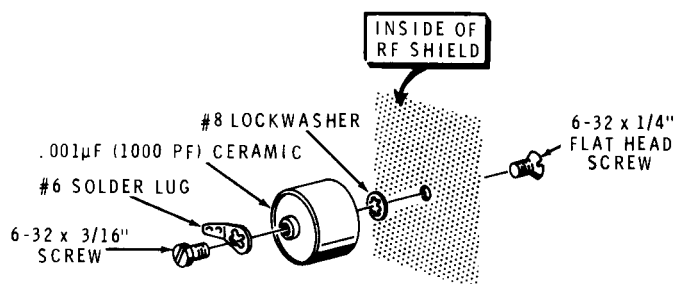

- (✓) C6: Refer to Detail 4-3E and mount a .001 μF ceramic capacitor (#21-165) at CM on the inside of the RF shield (this capacitor may be marked 1000 PF). Use a 6-32 × 1/4" flat head screw with a #8 lockwasher between the capacitor and the RF shield.

- (✓) Install a #6 solder lug on the other terminal of the capacitor with a 6-32 × 3/16" screw. Position the solder lug as shown.

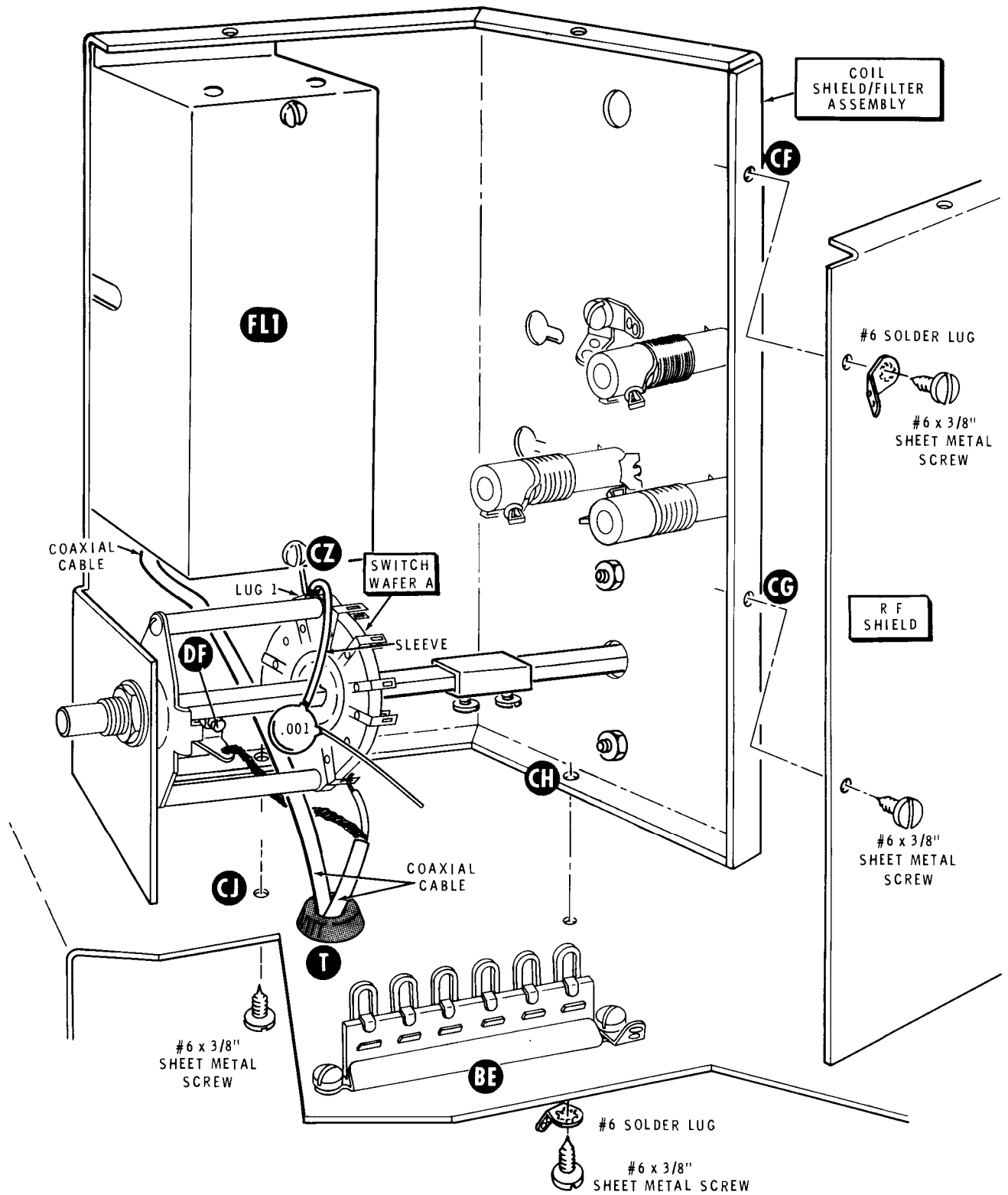

PICTORIAL 4-4

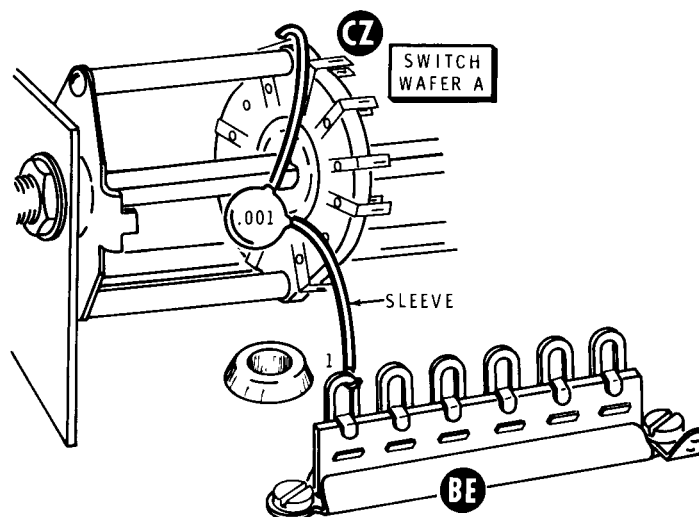

Detail 4-4A

Refer to Pictorial 4-4 for the following steps. For clarity, only the coil shield/filter assembly is shown.

(✓) Start the ends of the two coaxial cables coming from wafer A of switch CZ and from the filter assembly down through grommet T, and lower the input coil shield/filter assembly down onto the chassis. Pull the two coaxial cables through the grommet as you lower the assembly.

(✓) From the bottom of the chassis, install a #6 sheet metal screw and a #6 solder lug at CH in the coil shield/filter assembly.

(✓) From the bottom of the chassis, install a #6 sheet metal screw at CJ in the coil shield/filter assembly.

(✓) Make sure none of the parts on terminal strip BE contact any part on switch CZ.

(✓) Install a #6 sheet metal screw and a #6 solder lug at CF. Note the position of the solder lug.

(✓) Install a #6 × 3/8" sheet metal screw at CG.

(✗) Cut a 3/4" piece of small black sleeving. Use this sleeving in the next step.

(✓) Refer to Detail 4-4A and connect the free lead of the .001  $\mu$ F ceramic capacitor coming from lug 1 of the switch wafer to terminal strip BE lug 1 (S-3). Use 3/4" of sleeving on this lead.



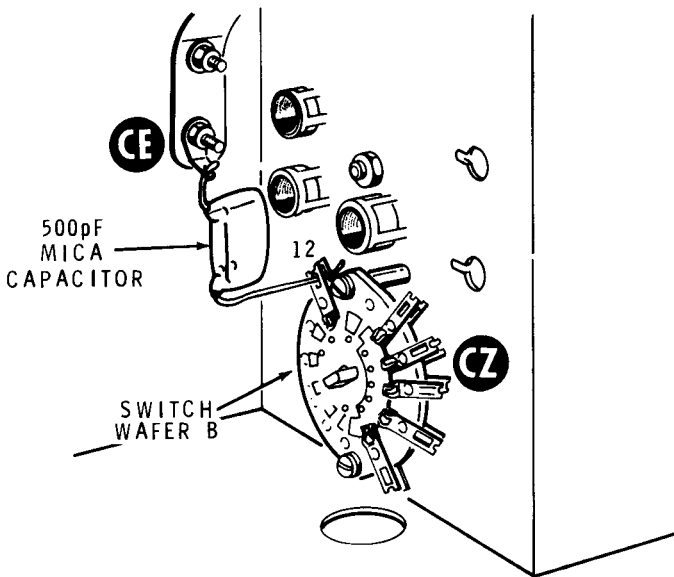

**Detail 4-5A**

Refer to Pictorial 4-5 (Illustration Booklet, Page 6) for the following steps.

- (✓) Refer to Detail 4-5A and connect the free end of the 500 pF mica capacitor at CE to rotary switch CZ, wafer B lug 12 (S-3). Be sure the capacitor lead is soldered to both lugs.

Refer to Detail 4-5B for the next two steps.

- (✓) Install two 7/8" tapped spacers on the 80/20 plate coil (#40-1666) assembly. Use 6-32 x 1/4" screws. Check to make sure the spacers do not touch the coil windings.
- (✓) L5: Mount the plate coil assembly at CB and CC on the inside of the RF shield. Be sure to position the coil so the taps are on the side toward the brass spring, and so the winding with the

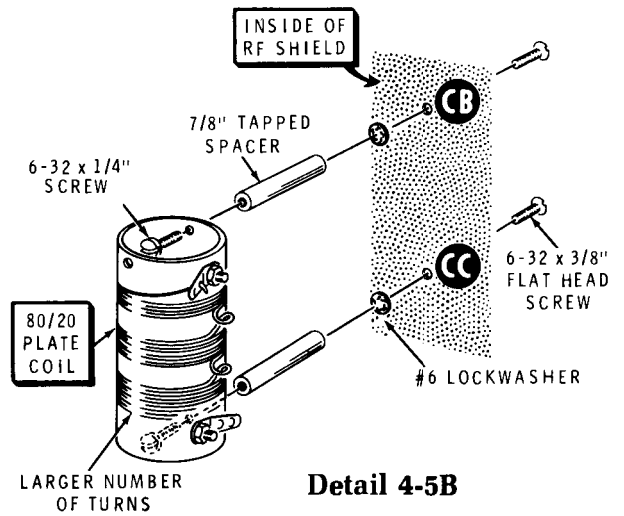

**Detail 4-5B**

larger number of turns is toward spacer CC. Use #6 lockwashers and 6-32 x 3/8" flat head screws.

- (✓) Refer to Detail 4-5C and install a ceramic feed-through insulator (#71-2) at CK. In addition to the parts in the plastic bag, use a 7/8" tapped spacer, two #6 solder lugs, and a 6-32 x 1/4" screw. Before the spacer is screwed onto the threaded stud running through the insulator, hold the brass spring down so it will bear against the under side of the installed spacer as shown in the Pictorial. Discard the unused nuts.

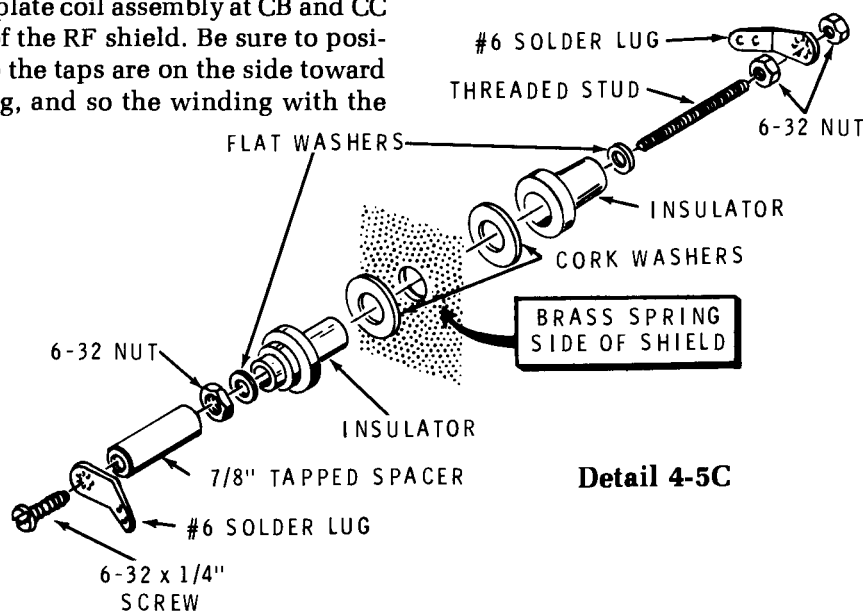

**Detail 4-5C**



NOTE: In the following steps, wires will be connected between switch CZ wafer B and the taps on the plate coil. Each wire should be fitted before it is soldered in place. The end of each wire going through the switch lugs must first be flattened as shown in the inset drawing of Detail 4-5E (Illustration Booklet, Page 6). **DO NOT** use the switch lugs to hold one end of the wire when forming it, as the switch lugs and the ceramic switch wafer can be damaged.

When soldering wires to the switch, make sure the wire is soldered to **both** switch lugs. After you fit the wires, cut off any excess wire lengths.

Refer to Detail 4-5D for the switch lug numbering system. The Detail shows the switch rotor as it was positioned when the shaft was installed (viewed from the rear).

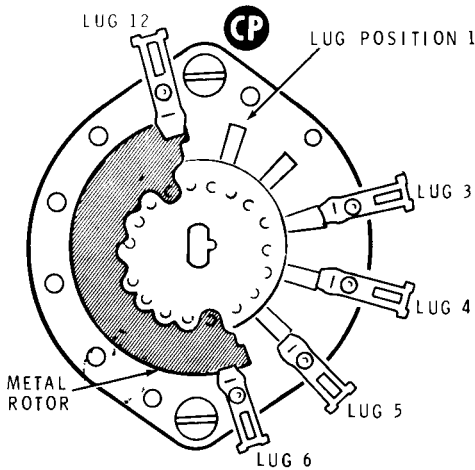

Detail 4-5D

Refer to Detail 4-5E (Illustration Booklet, Page 6) and connect medium bare wires from rotary switch CZ wafer B to the taps on the plate coil as follows. Be sure to connect to both lugs at each switch position.

Wire Length	Switch Lug No.	Coil Tap
-------------	----------------	----------

(✓) 1-1/2" 6 (S-3) 4 (S-1)

(✓) Refer to Detail 4-5F and bend the 4" length of large bare wire. Use the illustration as a template to form the wire. Then compress the hooks on the short end to fit the wire in the next step.

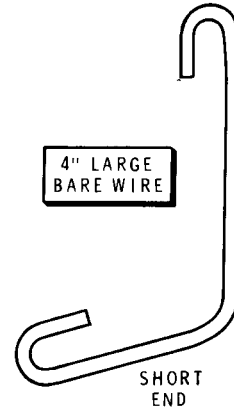

Detail 4-5F

(✓) Refer to Detail 4-5G and hook the short end of the bare wire around the switch wire at lug 4 of the 80/20 plate coil. Position the wire as shown. Then crimp but do not solder the hook to the wire.

Wire Length	Switch Lug No.	Coil Tap
(✓) 2-1/2"	5 (S-3)	3 (S-1)
(✓) 3"	4 (S-3)	2 (S-1)
(✓) 3-1/2"	3 (S-3)	1 (NS)*

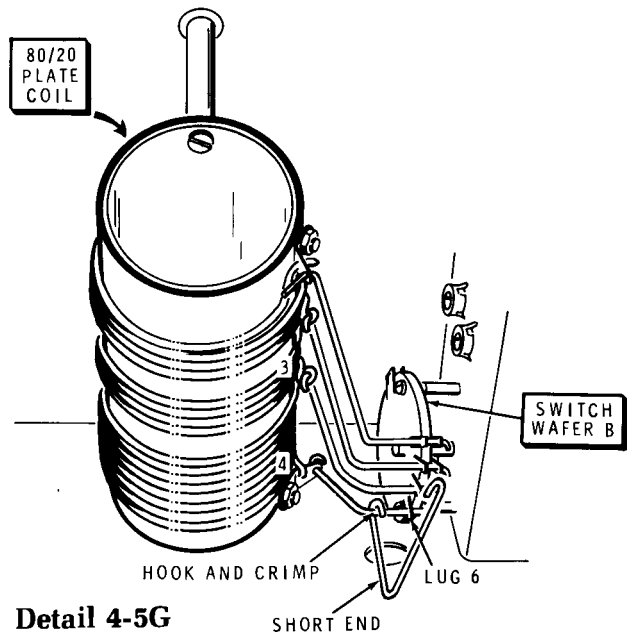

Detail 4-5G

\*Extend the wire 1/4" through the solder lug as shown in the upper inset.

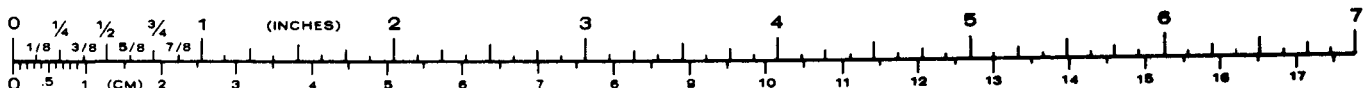



### PART 1

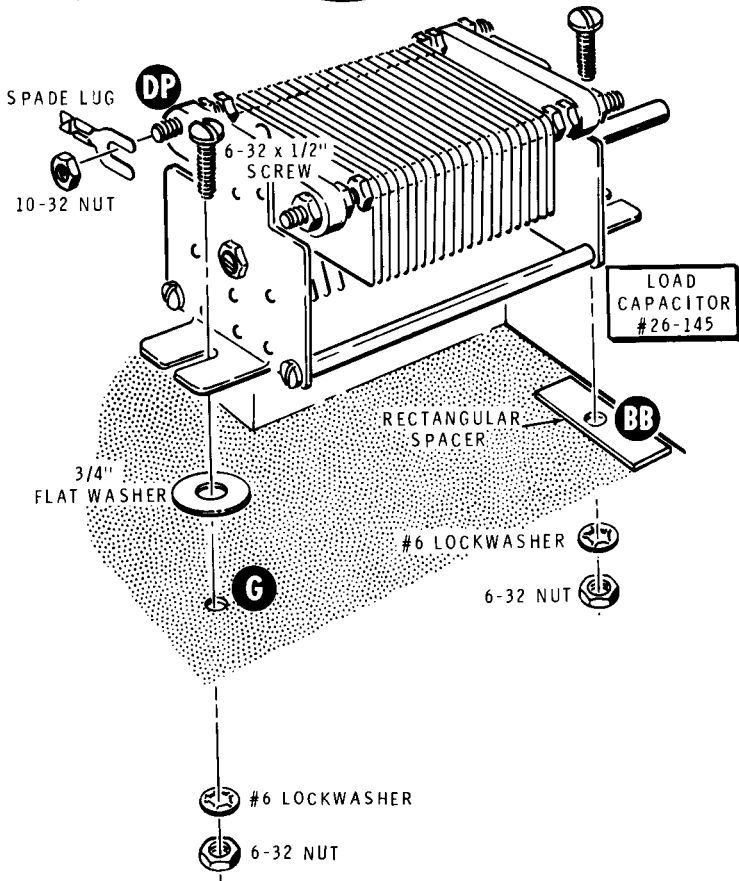
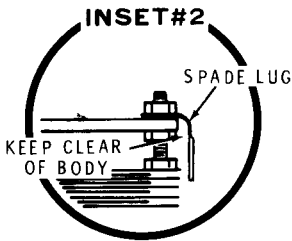
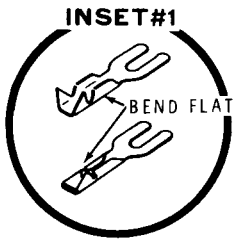

### PART 2

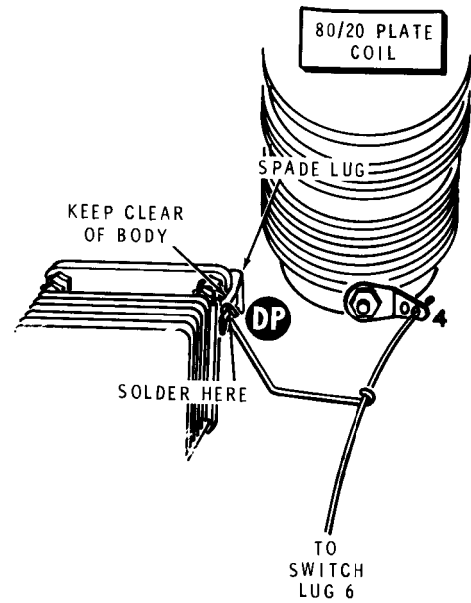

Detail 4-5H

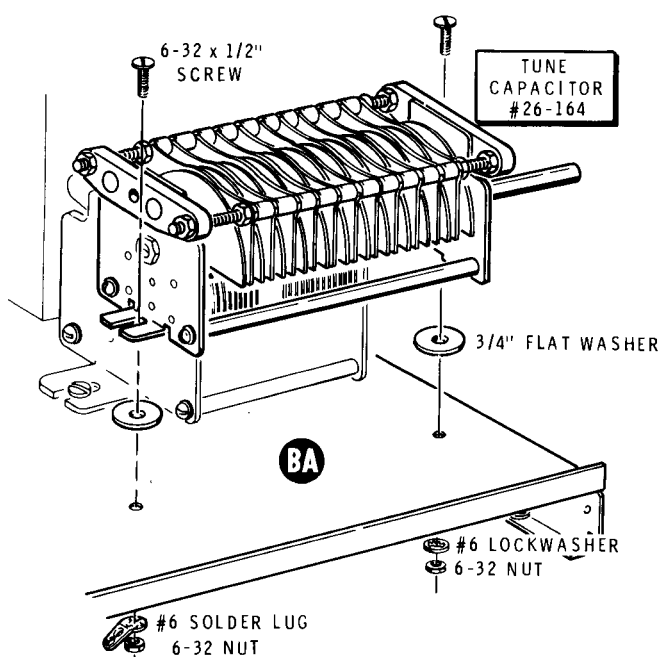

Detail 4-5J

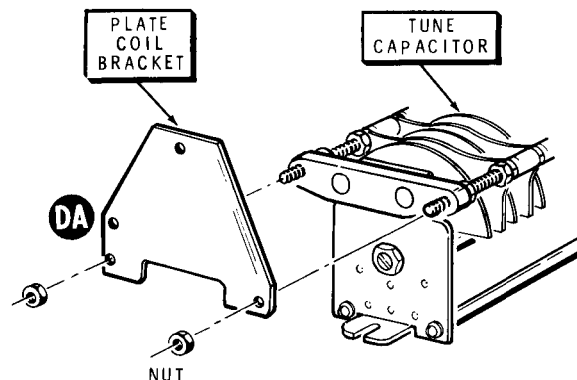

Detail 4-5K

Refer to Detail 4-5H Part 1 for the following numbered steps.

- (✓) 1. Close the end of the spade lug with a pair of pliers as shown in inset drawing #1.
- (✓) 2. Loosen the 10-32 nut on the Load capacitor (#26-145) at screw DP. Position the spade lug as shown and mount the lug on the screw. Retighten the nut.
- (✓) 3. Refer to inset drawing #2 and bend the spade lug over the edge of the capacitor 90° as shown.
- (✓) 4. Mount the prepared Load capacitor on the chassis. Use 6-32 × 1/2" hardware and a rectangular spacer at BB. Use 6-32 × 1/2" hardware and a 3/4" flat washer at G.

- (✓) Refer to Detail 4-5H Part 2 and hook the remaining end of the 4" large bare wire around the spade lug on the Load capacitor at DP. Crimp and solder both connections. Make sure the wire is positioned away from the capacitor body and any adjacent wiring.
- (✓) Refer to Detail 4-5J and mount the Tune capacitor (#26-164) at front and rear holes BA. Use two 6-32 × 1/2" screws, two 3/4" flat washers, a #6 solder lug, a #6 lockwasher, and two 6-32 nuts as shown.
- (✓) Refer to Detail 4-5K and use the following procedure to install the plate coil bracket (#204-2102) on the rear of Tune capacitor BA:
  1. Temporarily remove the nuts from the top studs on the back of the capacitor.
  2. Slide the plate coil bracket onto the studs. Be sure to position the bracket with hole DA as shown.
  3. Replace the nuts on the top capacitor studs to secure the bracket.

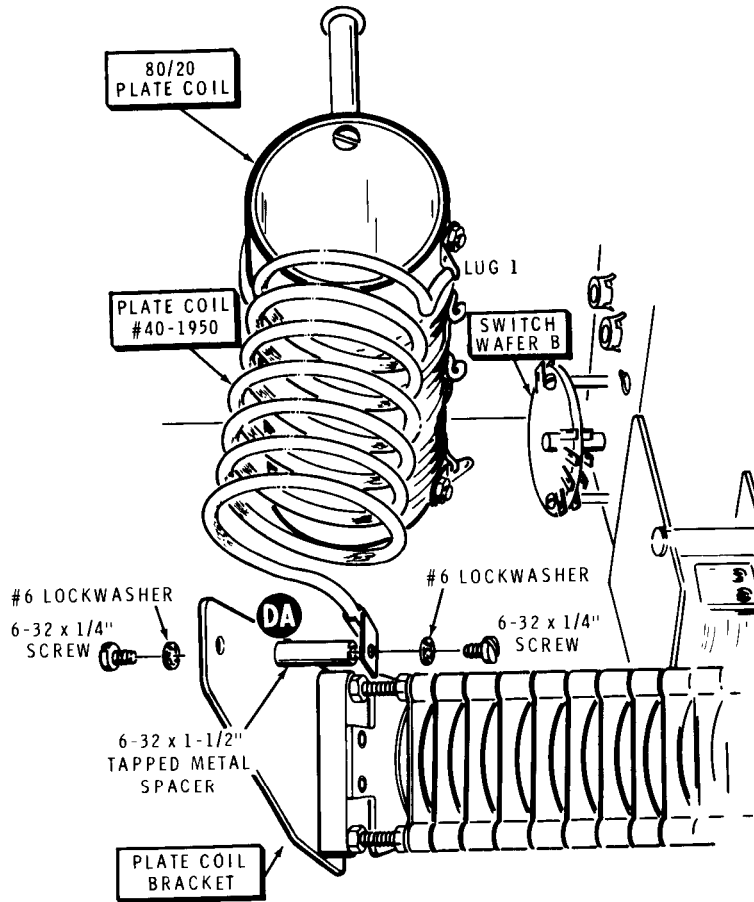

Detail 4-5L

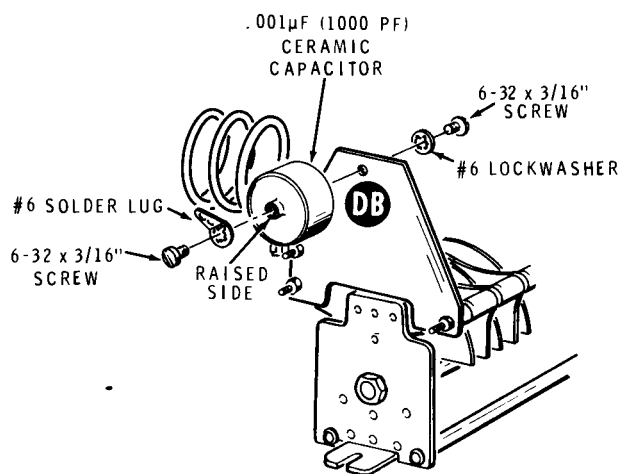

Detail 4-5M

- (✓) Refer to Detail 4-5L and mount a 6-32 × 1-1/2" tapped metal spacer at plate coil bracket hole DA. Use a 6-32 × 1/4" screw and a #6 lockwasher.

NOTE: In the following steps it may be necessary to slightly stretch the plate coil before you install it.

Refer to Detail 4-5L for the following steps.

- (✓) L4: Place the open end of the plate coil (#40-1950) tubing over the wire projecting from 80/20 plate coil lug 1. Form the solder lug so the coil tubing will butt snugly against it.
- (✓) Connect the tab on the coil to spacer DA with a 6-32 × 1/4" screw and a #6 lockwasher.
- (✓) Solder the coil tubing and the wire lead from the switch wafer to 80/20 plate coil lug 1. Make sure the end of the tubing is against the solder lug and that this connection is well soldered.

Refer to Detail 4-5M for the following steps.

- (✓) Install a #6 solder lug on the raised side of a .001 μF (1000 PF) ceramic capacitor (#21-165). Use a 6-32 × 3/16" screw.

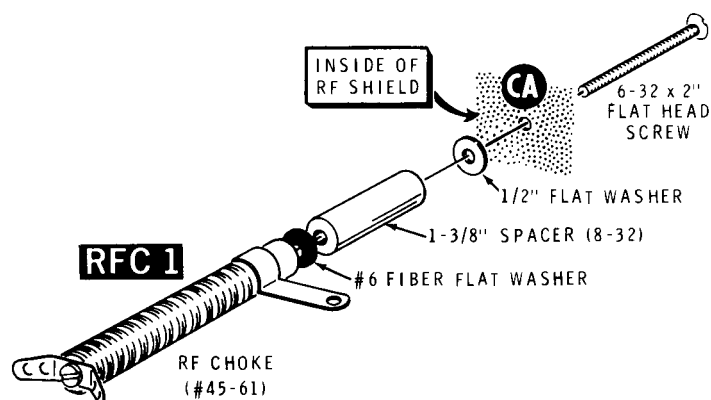

Detail 4-5N

- (✓) C29: Mount this capacitor at plate coil bracket hole DB. Use a 6-32 × 3/16" screw and a #6 lockwasher. Before tightening the screw, position the solder lug as shown.
- (✓) RFC1: Refer to Detail 4-5N and mount an RF choke (#45-61) at CA on the RF shield. Use a 1-3/8" spacer (8-32), a 1/2" flat washer, a #6 fiber flat washer, and 6-32 × 2" flat head screw. Do not overtighten the screw as the threads in the ceramic choke form can be damaged. Position the choke so solder lug DC points toward spacer DD.

Refer to Pictorial 4-5 for the next two steps.

- (✓) Connect a 1-1/2" medium bare wire from capacitor solder lug CM (S-1) to RFC1 solder lug DC (NS).
- (✓) RFC2: Cut each lead of RF choke (#45-6) to a length of 3/8". Connect one lead to choke lug DC (S-2) and the other lead to solder lug on spacer DD (S-1).

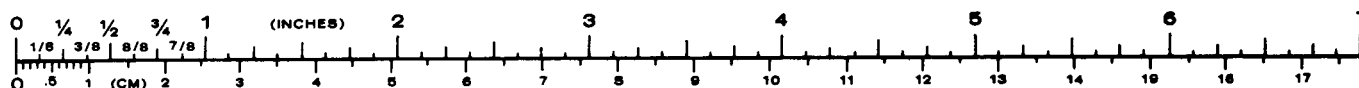

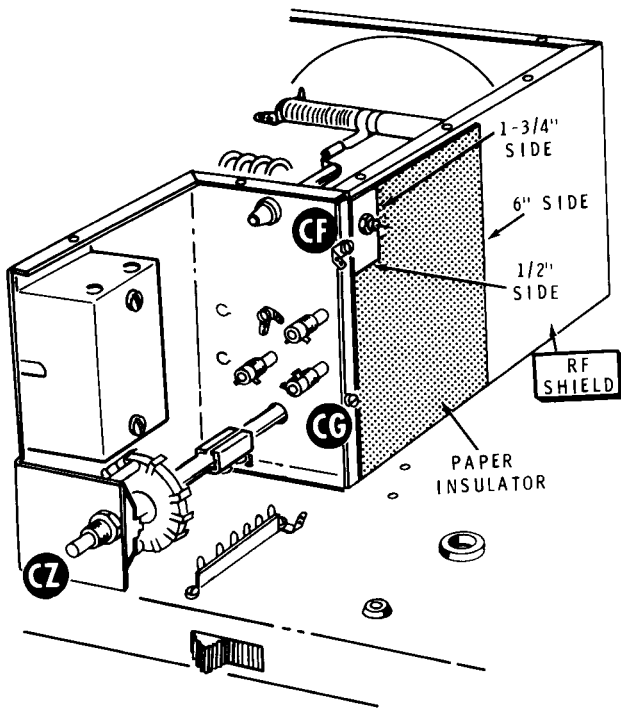

Detail 4-6A

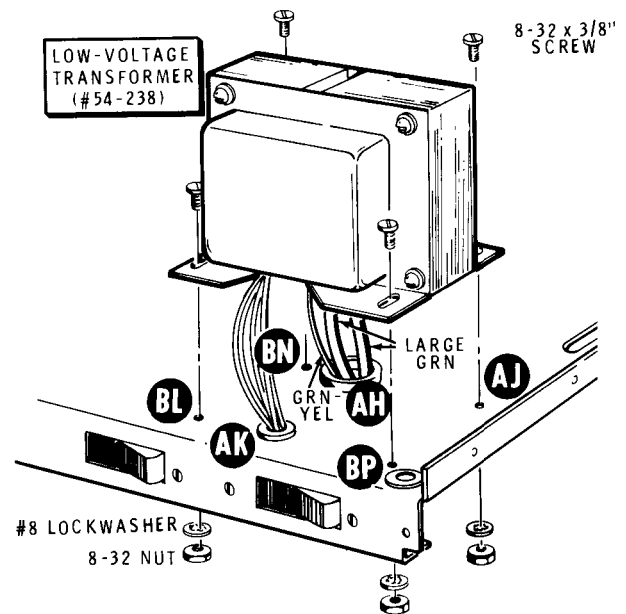

Detail 4-6B

Refer to Pictorial 4-6 (Illustration Booklet, Page 7) for the following steps.

- (✓) Refer to Detail 4-6A and cut a  $1/2'' \times 1-3/4''$  notch out one corner of the  $4-1/2'' \times 6''$  paper insulator as shown. Make sure the  $1-3/4''$  side of the notch is along the  $6''$  side of the paper insulator.
- (✓) Remove the paper backing from the paper insulator; then position the paper insulator with the  $6''$  side vertical and with the adhesive side against the RF shield. Make sure the insulator clears the zener diode and the sheet metal screw at CG. Rub the paper firmly into place.

- (✓) T2: Refer to Detail 4-6B and mount the low-voltage transformer (#54-238) on the top of the chassis. As you position the transformer, push the two large green leads and the green-yellow lead down through grommet AH. Push the other leads through grommet AK. Use  $8-32 \times 3/8''$  hardware at AJ, BL, BN, and BP. Position the transformer toward the front of the chassis as far as possible before you tighten the hardware.
- (✓) Temporarily remove the control nut and the control flat washer from rotary switch CZ (Detail 4-6A).

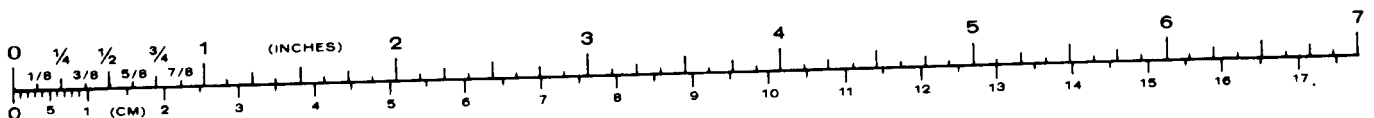

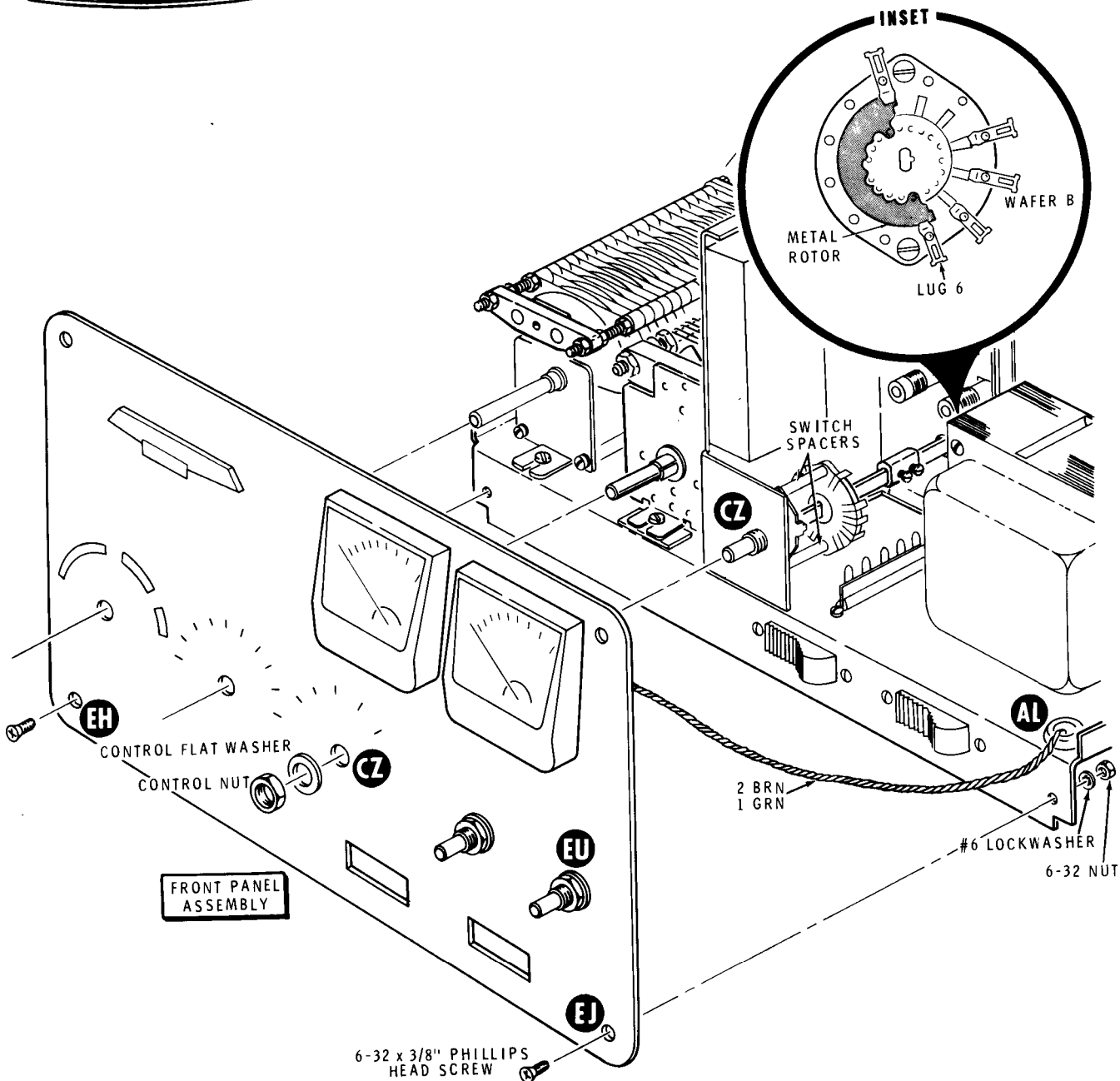

**Detail 4-6C**

(✓) Refer to Detail 4-6C and mount the front panel assembly on the front of the chassis. Push the twisted front panel wires (two brown and one green) down through grommet AL. Use 6-32 × 3/8" phillips head hardware at EH and EJ.

(✓) Replace the control flat washer and the control nut on switch CZ. Rotate switch shaft CZ fully counterclockwise. Make the nut just snug against the front panel.

(✓) Refer to the inset drawing and check the metal rotor of switch wafer B. Make sure the rotor edge does not rest too close to lug 5 or arcing will occur between the rotor and lug. If the rotor edge is too close to lug 5, carefully twist the switch spacers until the rotor is spaced correctly and then tighten the front panel nut securely.

(✓) Adjust the position of the low voltage transformer to insure at least 1/16" clearance between the transformer end bell and any connections to the lugs of front panel switch EU.

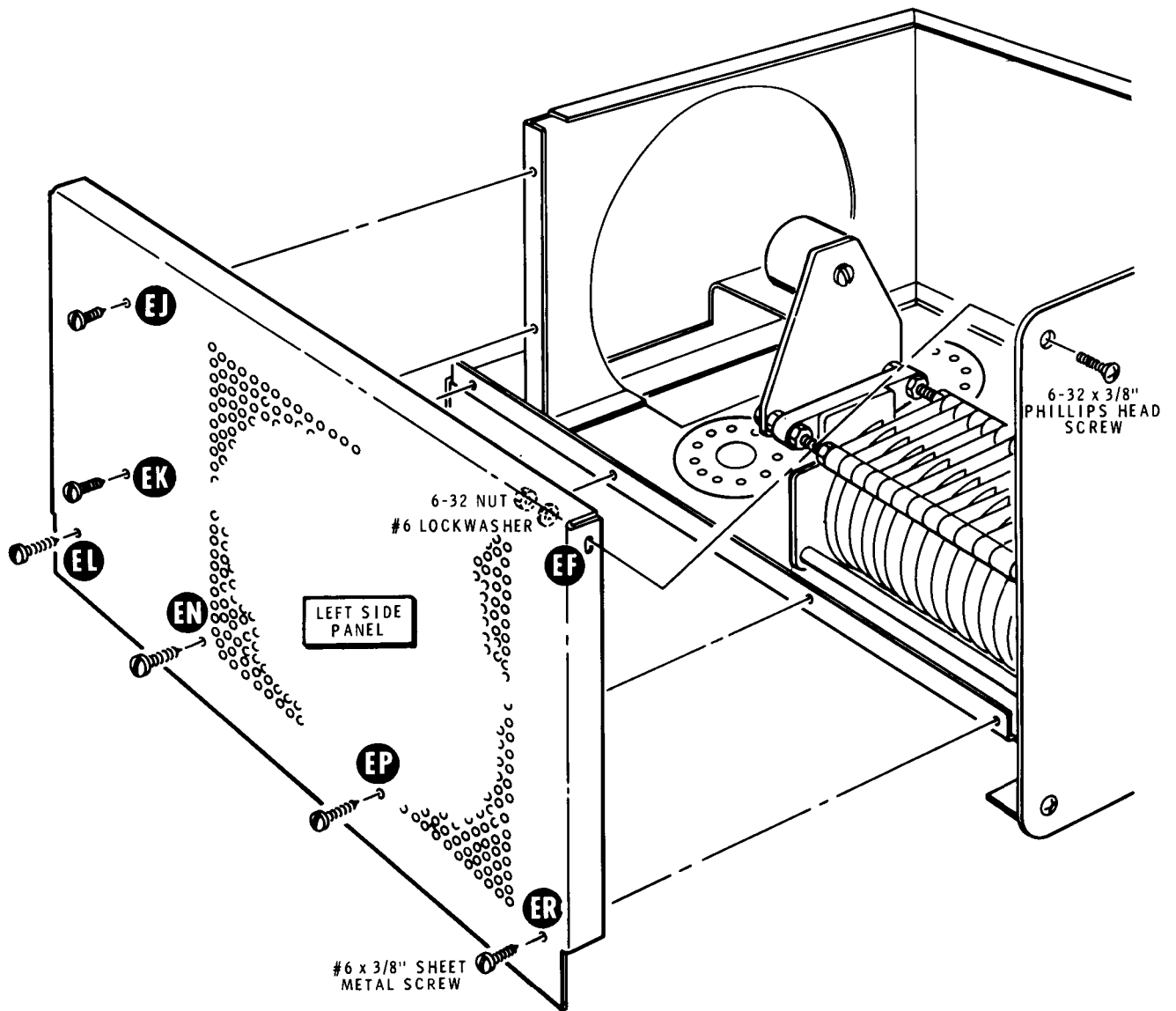

Detail 4-6D

(-) Refer to Detail 4-6D and install the left side panel (#203-646). Use 6-32 x 3/8" phillips

hardware at EF. Use #6 x 3/8" sheet metal screws at EJ, EK, EL, EN, EP, and ER.

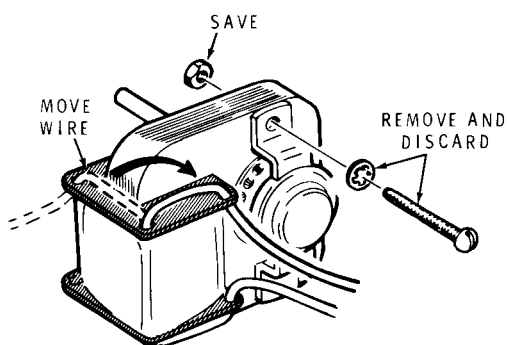

Detail 4-6E

Refer to Detail 4-6E for the next five steps.

**CAUTION:** Perform the next two steps carefully to avoid pulling the leads out of the motor winding.

- (✓) 1. Position the motor as shown. Then move one of the motor leads to the indicated hole in the plastic frame (away from the motor shaft).
- (✓) 2. Similarly, move the other motor lead to the indicated hole in the plastic frame.
- (✓) 3. Carefully remove the mounting hardware from **one side** of the motor as shown. Discard the screw and the lockwasher.

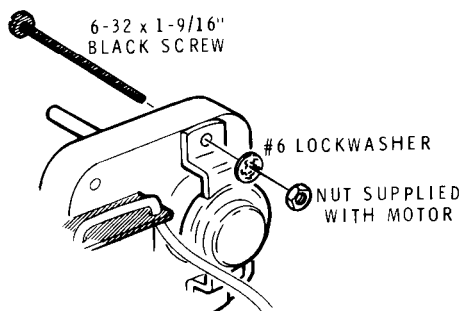

Detail 4-6F

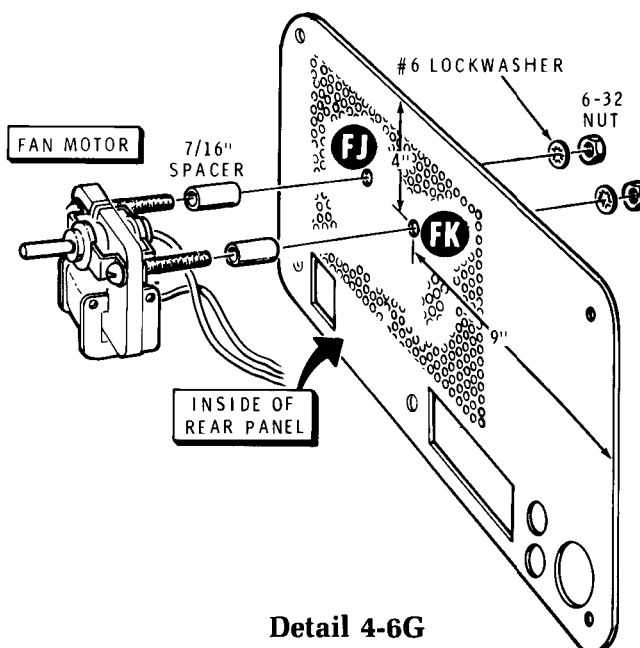

Detail 4-6G

- (✓) 4. Refer to Detail 4-6F and, from the shaft side of the motor, insert a 6-32 x 9/16" black screw through the mounting hole. Then secure the screw with a #6 lockwasher and the nut you removed in Step 3.
- (✓) 5. In the same manner, modify the hardware on the other side of the motor. Be sure to install the new screw from the shaft side of the motor.
- (✓) Position the rear panel as shown in Detail 4-6G. Then locate hole FJ. This hole is 4" down from the top edge of the panel and 9" in from the right edge of the panel.
- (✓) Refer again to Detail 4-6G and mount the fan motor on the rear panel at holes FJ and FK. Use two 7/16" spacers, two #6 lockwashers, and two 6-32 nuts as shown. **NOTE:** When you have the motor mounted correctly, the sides of the motor frame will be parallel to the edges of the panel.



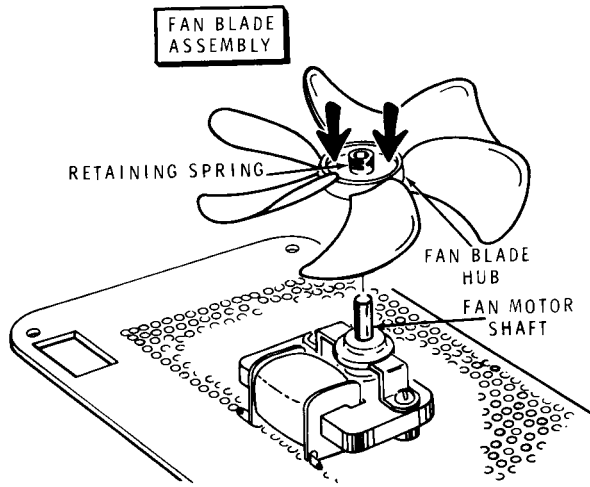

Detail 4-6H

- ✓) Refer to Detail 4-6H and install the fan blade assembly (#266-296) on the fan motor shaft. Position the fan motor and the blade assembly as shown, and apply firm downward pressure with both thumbs on the fan blade hub. A slight rocking motion will help. Push the fan blades onto the motor shaft until there is 1/16" to 1/32" clearance between the fan blade hub and the motor frame.

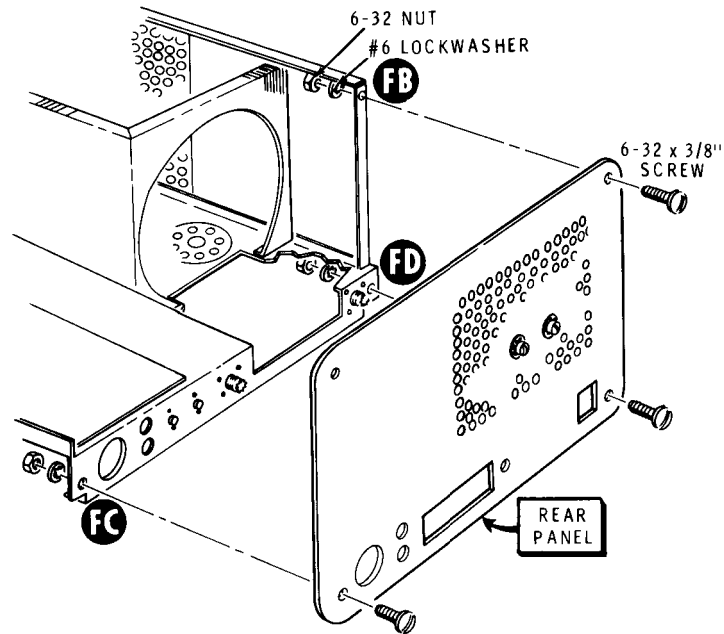

Detail 4-6J

- (✓) Refer to Detail 4-6J and mount the rear panel to the chassis rear apron at FC and FD, and to the left side panel at FB. Use 6-32 × 3/8" hardware.
- (✓) Rotate the fan blades to make sure they do not hit anything. Reposition the motor mounting as necessary.

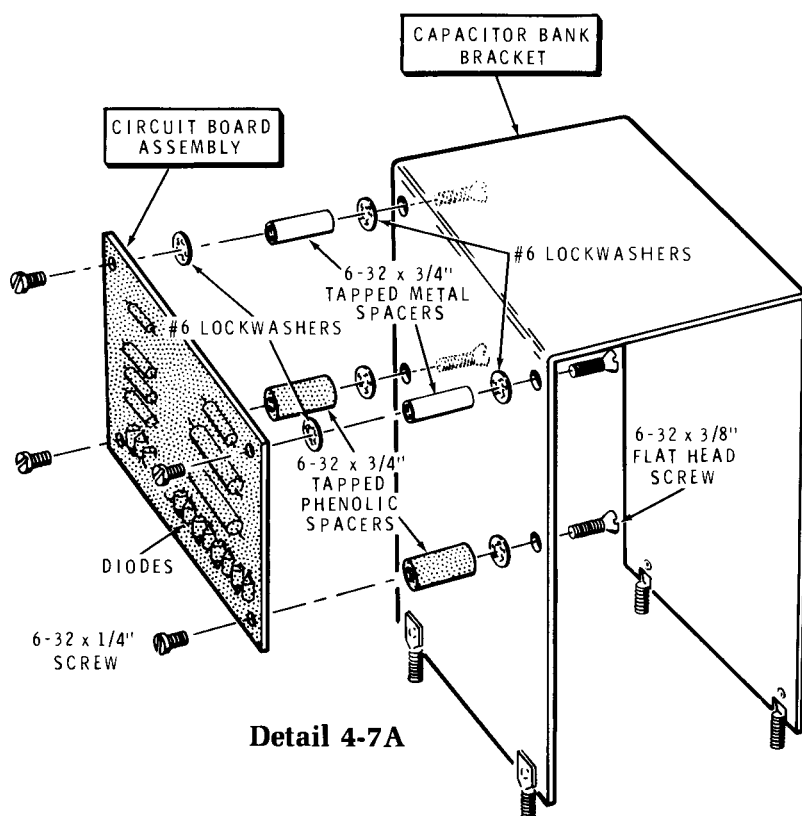

Detail 4-7A

Refer to Pictorial 4-7 (Illustration Booklet, Page 7) for the following steps.

- (v) Refer to Detail 4-7A and mount the circuit board assembly on the capacitor bank bracket. Use 6-32  $\times$  1/4" screws, 6-32  $\times$  3/4" tapped metal spacers, 6-32  $\times$  3/4" tapped phenolic spacers, 6-32  $\times$  3/8" flat head screws, and #6 lockwashers. Note that the diodes, and the phenolic spacers, are along the lower edge of the circuit board.
- (v) Refer to Detail 4-7B and mount the capacitor bank bracket with one spade bolt entering each of holes BR, BS, BT, and BU. Use #6 lockwashers and 6-32 nuts only on spade bolts BR, BS, and BU. Leave the nuts flush with the ends of the spade bolts.
- (v) Mount a 5-lug terminal strip (#431-42) on spade bolt BT. Use two #6 lockwashers and a 6-32 nut. Leave the face of the nut flush with the end of the spade bolt.

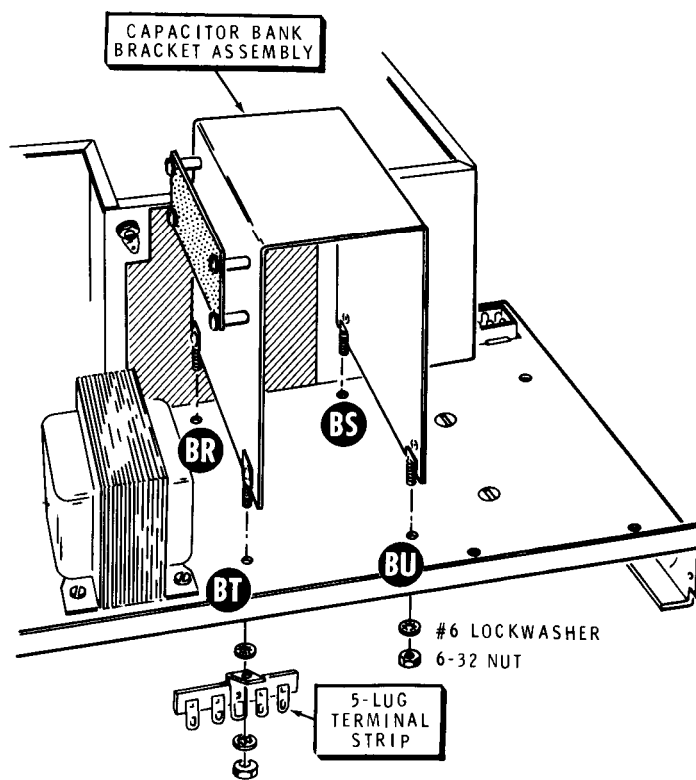

Detail 4-7B

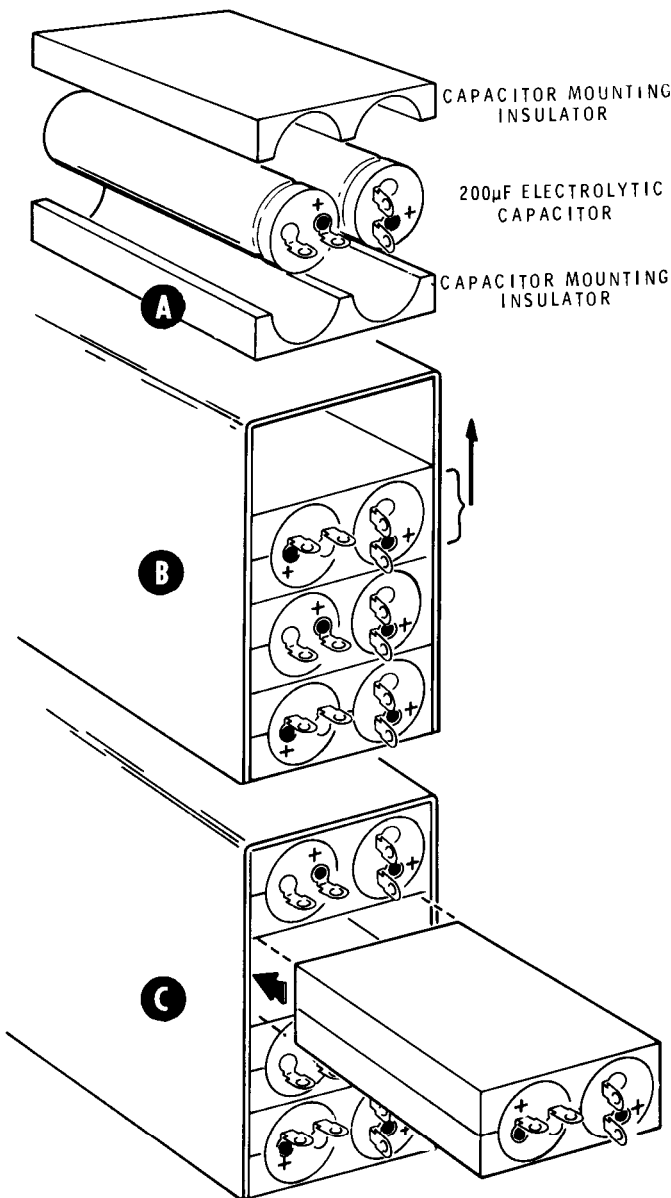

Detail 4-7D

Refer to Detail 4-7C for the steps covering the capacitor bank assembly, capacitors C10 through C17.

NOTE: The 200  $\mu$ F electrolytic capacitors supplied with your kit may have the terminal tabs on either side of the mounting rivet.

(✓) **Part A:** Assemble four capacitor sections, each composed of two capacitor mounting insulators (#75-125) and two 200  $\mu$ F electrolytic capacitors (#25-224).

(✓) **Part B:** Stack three capacitor sections in the capacitor bank bracket. Then lift up the top section to the top of the bracket.

(✓) **Part C:** Insert the fourth capacitor section into the vacated space in the bracket.

(✓) **Part D:** Align the capacitor lugs and the positive (+ or red dot) polarity markings as shown. Then push the capacitors snugly against the fish paper and tighten the spade bolt nuts on the bottom of the chassis just to the point where you can no longer rotate the capacitors with your fingers. Do not overtighten. Note the position of the terminal strip mounting foot in Detail 4-7B.

(✓) Refer to Detail 4-7D and cut four pieces of medium bare wire 1-5/8" long and one piece 1-3/8" long. Bend down 1/8" at one end of each. These wires will be used in the capacitor bank wiring.

( ) Cut four pieces of small black sleeving 3/4" long for use in wiring the capacitor bank.

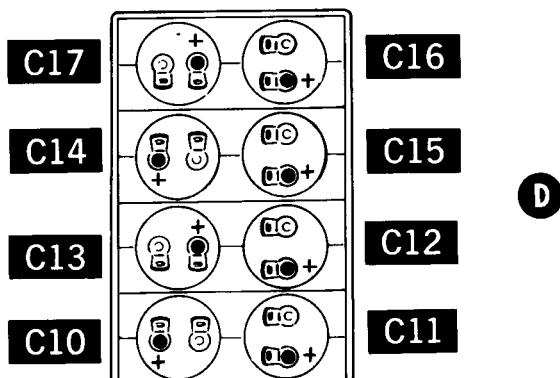

NOTE VARIANCE IN POLARITY MARKINGS

Detail 4-7C



NOTE: When you connect resistors in the following steps, align them as shown in the Pictorial. Space the resistors 1/2" from the capacitors as shown in the inset drawing. After fitting and soldering the resistors, cut off and discard any excess lead lengths. No resistor should be closer than 1/4" to any metallic object to which it is not intentionally connected.

- (✓) R18: Refer to the Pictorial 4-7 and place one of the 3/4" lengths of sleeving on one lead of a 30 k $\Omega$  resistor. Connect this lead to the positive (+ or red dot) lug of capacitor C17 (NS). Pass the other resistor lead through the positive lug of capacitor C16 (S-2) to the negative lug of capacitor C15 (NS).
- (✓) R14: Place one of the 3/4" lengths of sleeving on one lead of a 30 k $\Omega$  resistor and connect this lead to the positive lug of capacitor C13 (NS). Pass the other lead through the positive lug of capacitor C12 (S-2) to the negative lug of capacitor C11 (NS).
- (✓) Pass the straight end of one of the 1-5/8" bare wires through the negative lug of capacitor C16 (NS). Place the bent end of the wire into the positive lug of capacitor C17 (S-2).
- (✓) Connect the black hookup wire coming from circuit board hole B to the negative lug of capacitor C17 (NS).
- (✓) R19: Connect a 30 k $\Omega$  resistor from the negative lug of capacitor C17 (S-2) to the negative lug of capacitor C16 (S-2).
- (✓) Connect the bent end of one of the 1-5/8" bare wires to the negative lug of capacitor C14 (NS) and the straight end to the positive lug of capacitor C15 (NS).
- (✓) R17: Place a 3/4" length of sleeving on one lead of a 30 k $\Omega$  resistor and connect this lead to the negative lug of capacitor C14 (S-2). Connect the other lead to the negative lug of capacitor C15 (S-2).
- (✓) Place the bent end of a 1-5/8" bare wire in the positive lug of capacitor C13 (S-2), and the straight end in the negative lug of capacitor C12 (NS).
- (✓) R15: Connect a 30 k $\Omega$  resistor from the negative lug of capacitor C13 (NS) to the negative lug of capacitor C12 (S-2).
- (✓) Place the bent end of a 1-5/8" bare wire in the negative lug of capacitor C10 (NS) and the straight end in the positive lead of capacitor C11 (NS).
- (✓) R13: Place a 3/4" length of sleeving on one lead of a 30 k $\Omega$  resistor and connect this lead to the negative lug of capacitor C10 (S-2). Connect the other lead to the negative lug of capacitor C11 (S-2).
- (✓) Connect the blue wire from hole H of the circuit board to the positive lug of capacitor C10 (NS).
- (✓) R12: Connect one lead of a 30 k $\Omega$  resistor to the positive lug of capacitor C10 (S-2). Connect the other lead to the positive lug of capacitor C11 (S-2).
- (✓) R16: Connect one lead of a 30 k $\Omega$  resistor to the positive lug of capacitor C14 (NS). Connect the other lead to the positive lug of capacitor C15 (S-2).
- (✓) Connect the bent end of the 1-3/8" length of bare wire to the positive lug of capacitor C14 (NS) and the straight end to the negative lug of capacitor C13 (S-2).
- (✓) Carefully compare your work in the foregoing steps to the Pictorial (and the Details) for wiring errors and for proper capacitor polarity. Incorrect connections in this high-voltage circuit area can cause serious damage.

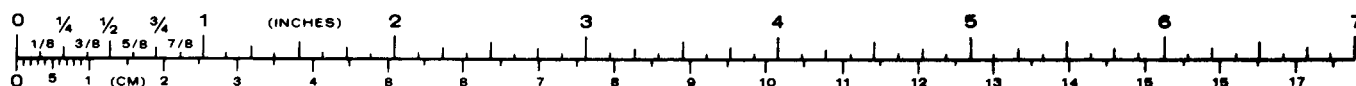

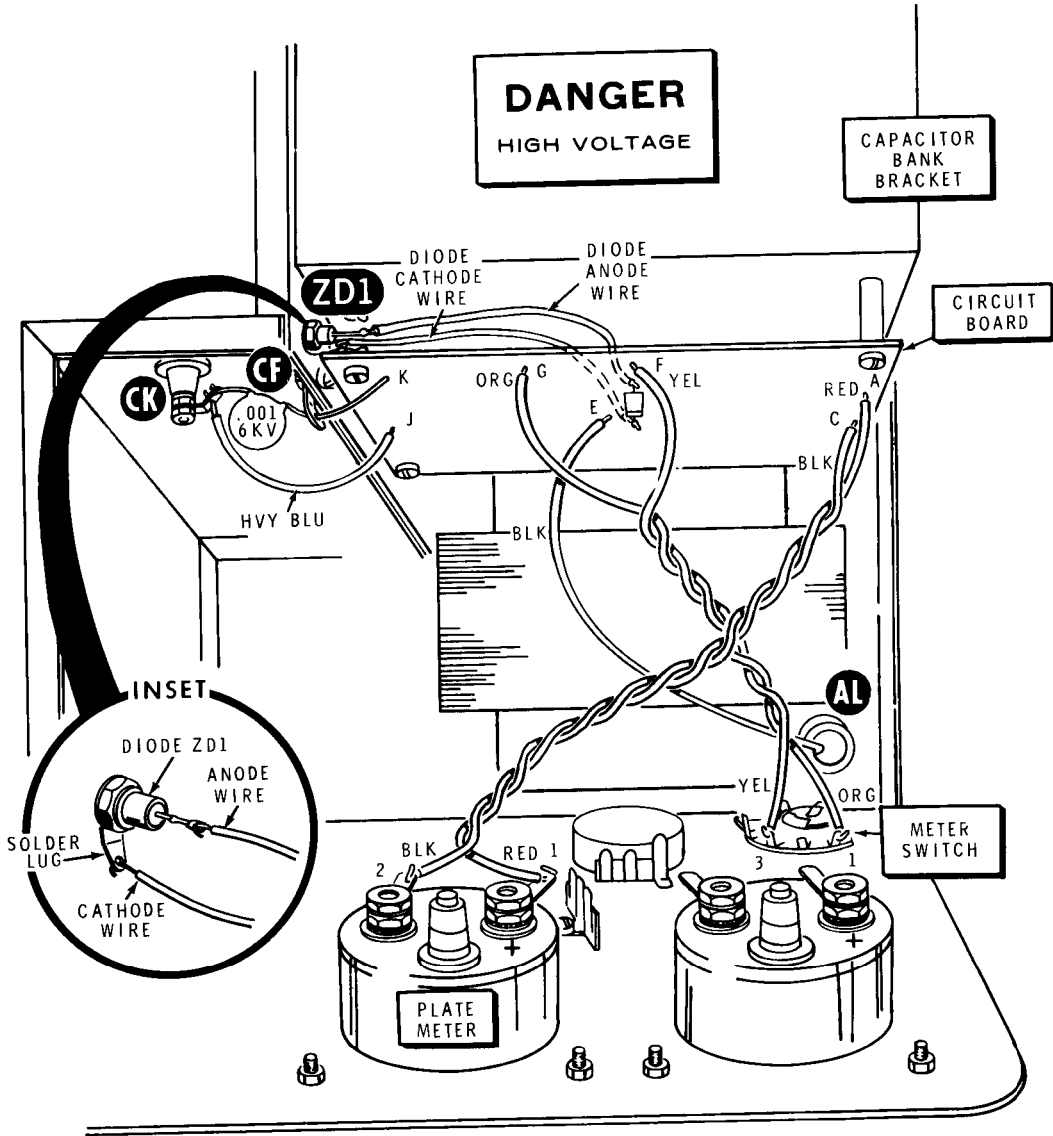

PICTORIAL 4-8

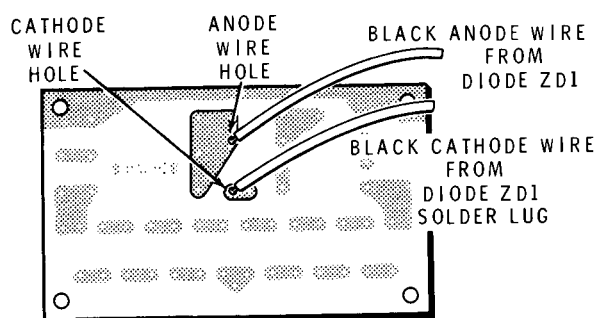

Detail 4-8A

Refer to Pictorial 4-8 for the following steps.

- (✓) C7: Pass one lead of a .001  $\mu$ F, 6 kV, capacitor through solder lug CF (S-2) to hole K in the circuit board (S-1). Connect the other lead of this capacitor to solder lug CK (NS).

Refer to the inset drawing of Pictorial 4-8 and Detail 4-8A for the next two steps.

- (✓) Connect the black cathode wire, coming from the solder lug of diode ZD1, to the foil side of the circuit board (S-1). Detail 4-8A shows the foil pattern.

- ( ) Connect the black anode wire, from diode ZD1 to the foil side of the circuit board (S-1). Refer to Detail 4-8A for the foil configuration.

Connect the wires coming from the component side of the circuit board as follows:

Wire Color	From Hole	Connect to
(✓) HVY Blue	J	Solder lug CK (S-2).
(✓) Yellow	F	Lug 3 of meter switch (S-1).
(✓) Orange	G	Lug 1 of meter switch (S-1).
(✓) Black	C	Lug 2 of plate meter (S-2).
(✓) Red	A	Lug 1 of plate meter (S-2).
(✓)	Insert the black stranded wire coming from hole E in the circuit board down through grommet AL.	
(✓)	Peel off the backing paper from the red "DANGER HIGH VOLTAGE" label and press it into place on the top of the capacitor bank bracket.	

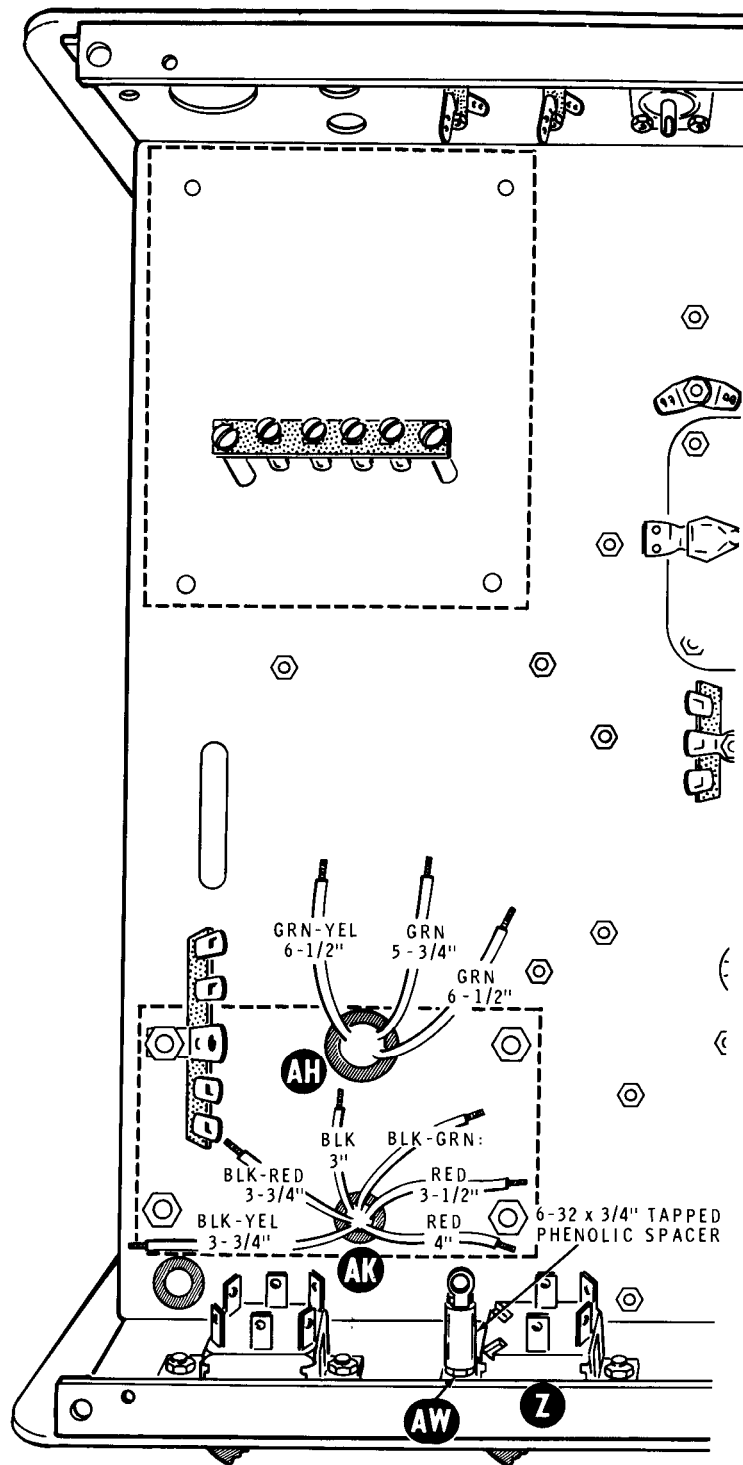

PICTORIAL 4-9



Detail 4-9A

## UNDER-CHASSIS WIRING

Refer to Pictorial 4-9 and cut the transformer leads coming through the chassis at AH and AK to the indicated lengths. Be sure you have selected the proper location before you cut. Measure the length of each lead from the chassis.

(✓) At grommet AH, cut the transformer leads as follows:

One large green	6-1/2"
Green-Yellow	6-1/2"
Other large green	5-3/4"

(✓) At grommet AK, cut the transformer leads as follows:

Black-Green	DO NOT cut
One red	4"
Other red	3-1/2"
Black-Red	3-3/4"
Black-Yellow	3-3/4"
Black	3"

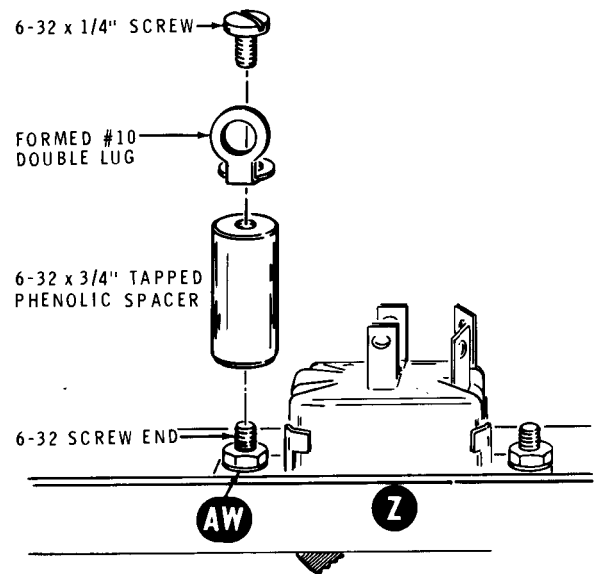

Detail 4-9B

NOTE: When you remove insulation from transformer leads in the following steps, grasp the wires where they emerge from the chassis so no strain will be placed on the connections at the transformer end of the leads.

(✓) Remove 1/4" of insulation from the cut ends of the two heavy green leads coming from AH. Melt a **small** amount of solder on the bared wire ends.

(✓) Remove 1/4" of insulation from the end of each remaining transformer lead coming from AH and AK. Twist the fine wire strands together and melt a **small** amount of solder on each bared end.

(✓) Refer to Detail 4-9A and form a #10 double lug (#259-25) as shown.

(✓) Refer to Detail 4-9B and screw a 6-32 x 3/4" tapped phenolic spacer onto screw AW. Then install the formed lug on the inner end of the phenolic spacer with a 6-32 x 1/4" screw. Position the lug as shown.

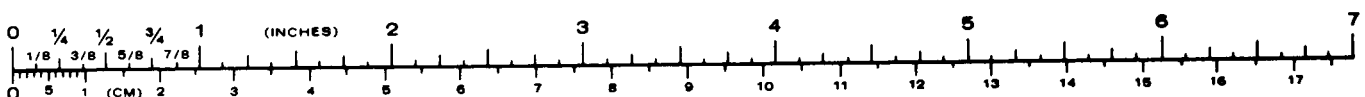



**NOTE:** Before you start the wiring in the following steps, look ahead to the under-chassis photograph on Page 93. Observe how wires are routed down the center of the chassis and are then bound together by ties to form a cable. As an aid in forming a neat cable, you can mark the main wiring guide lines on the underside of the chassis with a magic marker or china marking pencil. Then follow these guide lines when routing the individual wires.

Refer to Pictorial 4-10 (Illustration Booklet, Page 8) for the following steps.

- (✓) Route the twisted green and brown wires from grommet AL between grommet AH and grommet AK. Refer to Detail 4-10A and connect one of the brown wires to lug 1 (NS) and the other brown wire to lug 3 (NS) of terminal strip P.

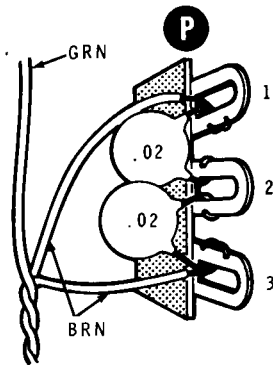

**Detail 4-10A**

- (✓) C22: Connect a .02  $\mu$ F ceramic capacitor between terminal strip P lugs 1 (NS) and 2 (NS).
- (✓) C23: Connect a .02  $\mu$ F ceramic capacitor between terminal strip P lugs 3 (NS) and 2 (S-2) of terminal strip P.
- (✓) Connect the green wire from grommet AL to terminal strip B lug 1 (NS).

Connect the transformer leads from grommet AK as follows:

<u>Lead</u>	<u>Connect to</u>
(✓) 4" Red	Terminal strip BT, lug 3 (NS).
(✓) 3-1/2" Red	Terminal strip BT, lug 4 (NS).
(✓) Black-green	Terminal strip AE, lug 3 (NS).

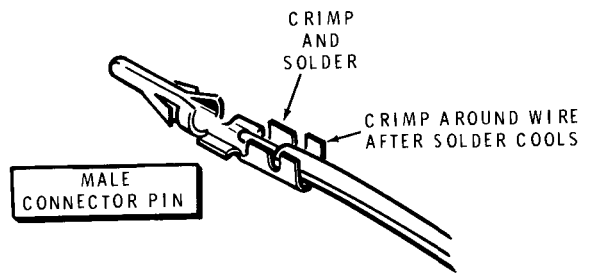

**Detail 4-10B**

- (✓) Prepare the following large stranded wires:

13-1/2" black

7" white

- (✓) Refer to Detail 4-10B and install male connector pins (#432-862) on one end of each of the prepared wires.

**NOTE:** When you insert the male connector pins into the holes of socket Y, in the following steps, be sure to insert the pins into the correct holes. These pins are almost impossible to remove once they lock into place.

- (✓) Push the male connector pin on the end of the 13-1/2" black wire into socket Y hole 1 until it locks in place. Connect the free end of this wire to double solder lug AW (NS). Make a secure mechanical connection as shown in inset drawing #1 on the Pictorial.

- (✓) Push the male connector pin on the end of the 7" white wire into socket Y hole 4 until it locks in place. Connect the free end of this wire to terminal strip AE lug 3 (S-2). Make a secure mechanical connection.

- (✓) Prepare the following large stranded wires:

13-1/2" red      14" white

13-1/2" black      15" red

- (✓) Install male connector pins (#432-862) on one end of each of the prepared wires. Use the same procedure as before.

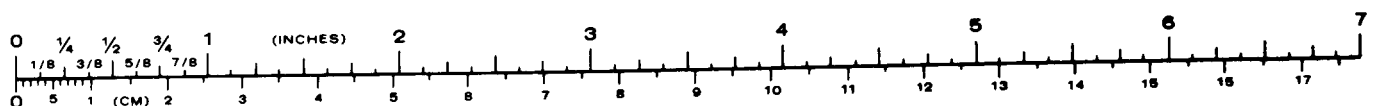

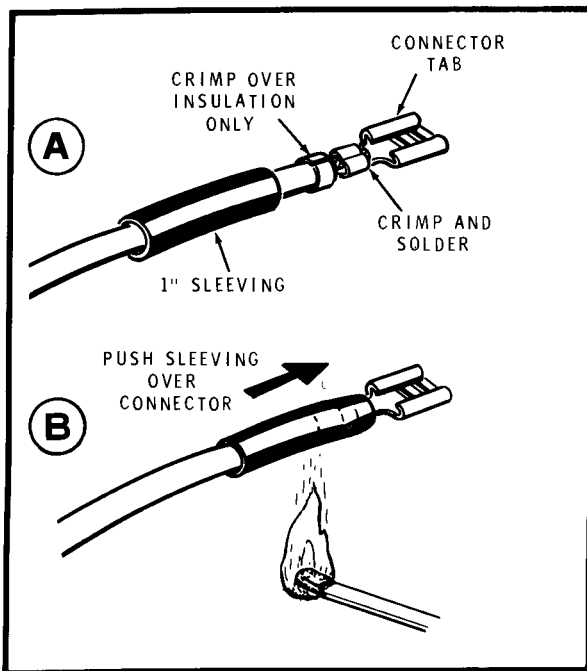

Detail 4-10C

( ) Refer to Detail 4-10C and prepare the free ends of the four wires as follows:

1. Cut four 1" lengths of large black (heat shrinkable) sleeving. Place a length of sleeving on each wire.
2. Crimp and solder a connector tab (#432-137) onto the free end of each wire as shown in Part A.
3. Slide the sleeving down until it is onto the top of the connector. With a match or other heat source, shrink the sleeving onto each connector as shown in Part B.

NOTE: When you connect each of the four prepared wires, in the the following steps, first push the male connector pin on the wire into the indicated hole of socket Y (until it locks in place). Then push the connector tab on the other end of the wire onto the indicated lug of switch AN.

Connect the four prepared wires as follows:

- ( ) 13-1/2" red from socket Y hole 2 to switch AN lug 1.
- ( ) 13-1/2" black from socket Y hole 5 to switch AN lug 2.

- ( ) 14" white from socket Y hole 3 to switch AN lug 5.
- ( ) 15" red from socket Y hole 6 to switch AN lug 6.
- ( ) Prepare a 2" length of black hookup (solid) wire.
- ( ) Connect the 2" black wire between terminal strip BT lugs 3 (S-2) and 1 (NS).
- ( ) Connect the yellow hookup wire coming from grommet T to phono socket U lug 1 (NS).
- ( ) Connect the orange wire coming from grommet T to terminal strip BT lug 2 (NS).

Refer to Detail 4-10C for the next three steps.

- ( ) Prepare a 4" length of large black stranded wire.
- ( ) Install one of the connector tabs onto one end of the 4" large black stranded wire (S-1).

- ( ) Cut a 1" piece of large black heat-shrinkable sleeving. Shrink the sleeving over the end of the connector on the 4" wire.

Refer to Pictorial 4-10 (Illustration Booklet, Page 8) for the following steps.

- ( ) Push the connector tab from the preceding step onto switch Z lug 3. Connect the other end of this wire to double lug AW (NS).
- ( ) Connect the black lead coming from grommet AK to double lug AW (NS). Make a secure mechanical connection.
- ( ) Locate the shielded cable coming from grommet T, the end of which is prepared as shown in Detail 4-10D. Connect the center conductor of this coaxial cable to terminal strip AG lug 1 (NS). Connect the shield lead to lug 2 (S-1). NOTE: Be sure this is the cable coming from filter FL1.

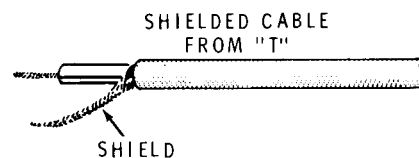

Detail 4-10D

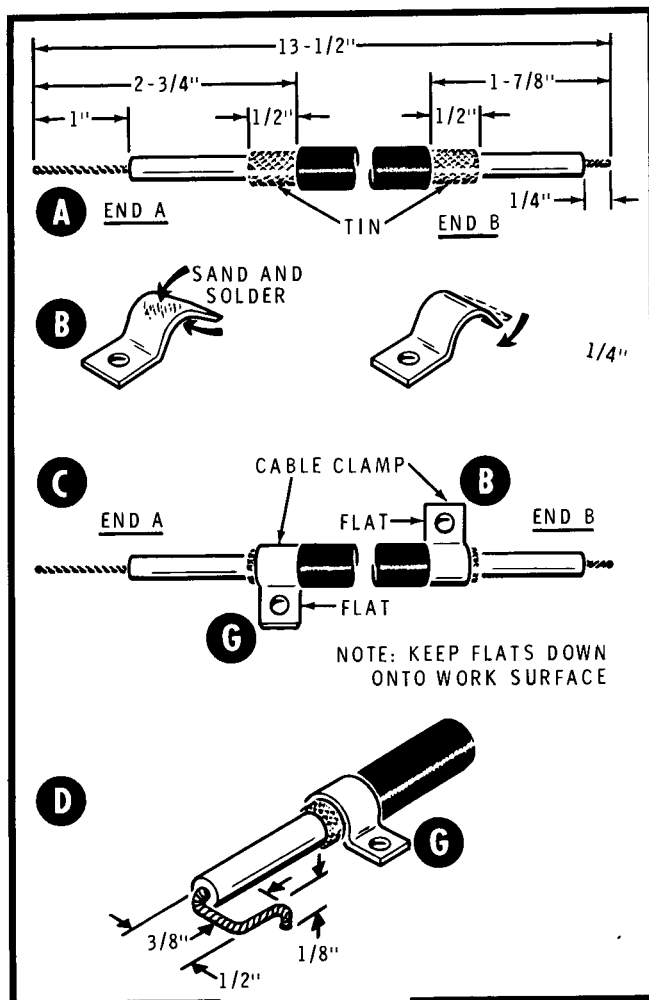

Detail 4-10E

Refer to Detail 4-10E for the next six steps.

- ( ) 1. Refer to Part A of the Detail and prepare a 13-1/2" length of RG-8/U coaxial cable as shown. Tin the exposed braid at each end, being careful not to melt the inner insulation.
- ( ) 2. Locate two cable clamps (#207-8). Refer to Part B of the Detail and on the inside and on top of the curved portion of each clamp, thoroughly sand each clamp to remove the outer coating. Apply a good coating of solder to both the inside and outside of the sanded clamp (only the curved portion).
- ( ) 3. Slightly squeeze the curved portion of both clamps to form a symmetrical half-circle.

NOTE: Carefully study Part C of Detail 4-10E and note the position of the clamps at end A and at end B of the

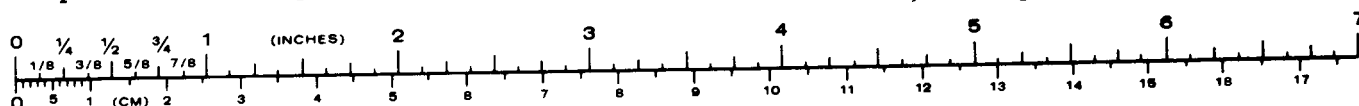

cable. When you install the clamps, both of them must fit over the tinned cable braid, and the flat on each of them must be flat against the top of your work surface.

- ( ) 4. Install and solder a cable clamp onto end A of the 13-1/2" shielded cable exactly as shown in Part C of the Detail.
- ( ) 5. Similarly, install and solder the other cable clamp on end B of the cable.
- ( ) 6. Refer to Part D of Detail 4-10E and form the inner lead at end A of the shielded cable as shown.

Refer to Detail 4-10F for the next two steps.

- ( ) At end A of the RG-8/U coaxial cable, connect the inner lead to relay K1 lug 8 (S-1).

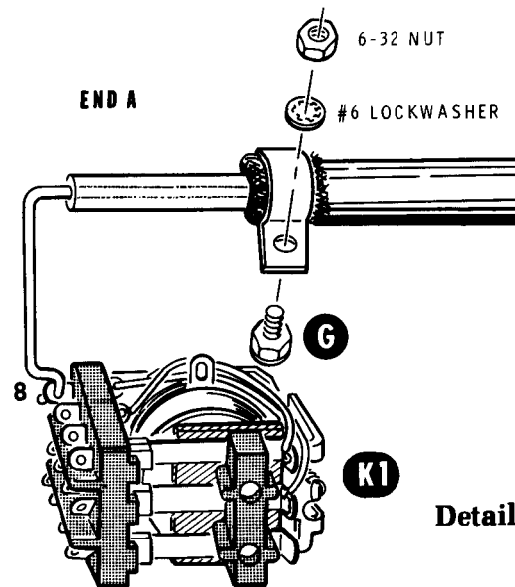

Detail 4-10F

- ( ) Secure the cable clamp at cable end A to the end of the screw at G with a #6 lockwasher and a 6-32 nut.
- ( ) Refer to Detail 4-10G and, at cable end B, solder the inner lead to coaxial jack A (S-1). Then secure the cable clamp to the top of the 5/16" tapped spacer at B with a #6 lockwasher and 6-32 x 3/16" screw as shown.

Refer to Pictorial 4-11 (Illustration Booklet, Page 8) for the following steps.

- ( ) Cut three 1" pieces of large black (heat-shrinkable) sleeving.

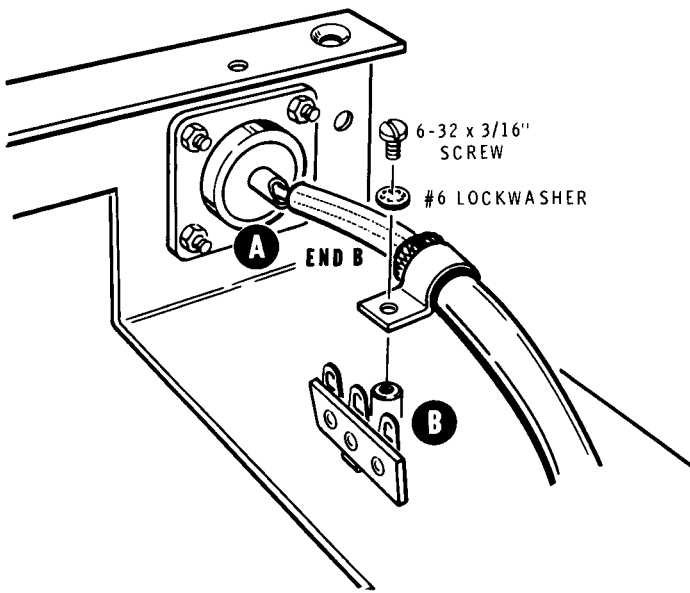

Detail 4-10G

- ( ) Prepare the following lengths of **large** black stranded wire:

4-1/2"

13-1/2"

13-1/2"

- ( ) Install a connector tab (#432-137) and a 1" sleeve on **one** end of **each** of the three wires. Shrink the sleeve onto the wires and connectors as in a previous step.
- ( ) Push the tab on the 4-1/2" wire onto switch AN lug 4.
- ( ) Push the connector tab on one of the 13-1/2" wires onto switch Z lug 1.
- ( ) Push the connector tab on the other 13-1/2" wire onto switch Z lug 2.
- ( ) Prepare a 12-1/2" length of **large** black stranded wire.
- ( ) Connect the free end of the black-yellow wire coming from grommet AK and one end of the 12-1/2" wire prepared in the preceding step to one tab connector (S-2). Then push this connector tab onto switch AN lug 3.

- ( ) Connect the free end of the black-red lead coming from grommet AK and the free end of the black wire coming from lug 4 of switch AN to one tab connector (S-2). Push this tab onto switch Z lug 4.

The free ends of the "tabbed" wires prepared in the preceding steps will be connected later.

- ( ) D16: Refer to the Detail 4-11A (Illustration Booklet, Page 8) and connect a 1N2071 diode (#57-27) between terminal strip BT lugs 4 (S-2) and 5 (NS). Be **sure** to position the banded end as shown in Pictorial 4-11.
- ( ) R5: Connect a 27 kΩ (red-violet-orange) resistor between terminal strip BT lugs 1 (NS) and 2 (NS).
- ( ) Cut two 1/2" pieces of small black sleeving.
- ( ) R4: Place a 1/2" piece of sleeving on each lead of a 27 kΩ (red-violet-orange) resistor. Then connect the resistor between terminal strip BT lugs 2 (S-3) and 5 (NS).

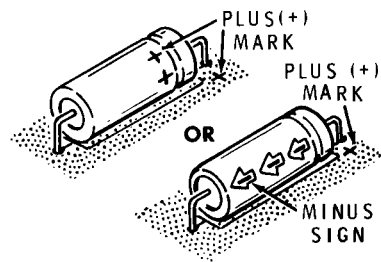

Detail 4-11B

- ( ) C4: Refer to Detail 4-11B and connect the positive (+) lead of a 20 μF electrolytic capacitor to terminal strip BT lug 5 (NS). Connect the other lead to lug 1 (S-3).
- ( ) Connect the black stranded wire coming from grommet AL to relay K1 lug 6 (S-1).
- ( ) Prepare a 2" and an 8-1/2" red wire.
- ( ) Connect a 2" red wire between relay K1 lugs 3 (NS) and 11 (S-1).
- ( ) Connect an 8-1/2" length of red wire from terminal strip BT lug 5 (S-4) to relay K1 lug 3 (NS).

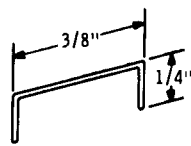

**Detail 4-11C**

- (✓) Refer to Detail 4-11C and form a 7/8" length of medium bare wire as shown.
- (✓) Connect the bare wire between relay K1 lugs 1 (S-1) and 2 (S-1).

Refer to Pictorial 4-12 (Illustration Booklet, Page 9) for the following steps.

- (✓) Connect the green-yellow transformer lead from grommet AH to relay K1 lug 9 (NS).
- (✓) Prepare a 13" length of small blue wire.
- (✓) Connect the 13" blue wire from relay K1 lug 10 (S-1) to phono socket X lug 1 (NS).
- (✓) C52: Connect a .02  $\mu$ F ceramic capacitor from between phono socket X lugs 1 (S-2) and 2 (NS).
- (✓) C53: Connect a .02  $\mu$ F ceramic capacitor from phono socket U lug 1 (S-2) to phono socket X lug 2 (S-2).

Connect 115 pF mica capacitors (#20-124) to tube socket lugs as follows:

<u>Tube Socket and Lug</u>	<u>Connect to</u>
(✓) C26: Socket D, lug 4 (S-1)	Solder lug E (S-1).
(✓) C19: Socket D, lug 3 (S-1)	Solder lug C1 (NS).
(✓) C16: Socket D, lug 2 (NS)	Solder lug C2 (S-1).
(✓) C28: Socket N, lug 3 (S-1)	Solder lug M2 (NS).
(✓) C31: Socket N, lug 4 (NS)	Solder lug M1 (S-1).
(✓) C27: Socket N, lug 2 (S-1)	Terminal strip P, eyelet of lug 2 (S-1). *

\*NOTE: Form the leads of C27 so the body of the capacitor is close to the under side of the chassis.

- (✓) RFC4: Connect a 1 mH RF choke (#45-4) from tube socket D lug 2 (S-2) to solder lug C1 (S-2).
- (✓) RFC5: Connect a 1 mH RF choke (#45-4) from tube socket N lug 4 (S-2) to solder lug M2 (S-2).
- (✓) C54: Connect a .02  $\mu$ F ceramic capacitor between terminal strip B lug 1 (NS) and lug 2 (NS).
- (✓) Connect one lead of a 1000  $\Omega$  (brown-black-red) resistor between terminal strip B lugs 2 (S-2) and 3 (NS).
- (✓) D17: Connect the banded lead of a 1N191 diode (#56-26, brown-white-brown) to terminal strip B lug 1 (S-3). Connect the other lead to lug 3 (NS).
- (✓) R24: Connect one lead of a 68 k $\Omega$  (blue-gray-orange) 1 watt resistor to terminal strip B lug 3 (S-3). Hook the other lead of this resistor around coaxial connector A as shown in inset drawing 1 of Pictorial 4-12 (S-1).
- (✓) Refer to Detail 4-12A and form a 3" length of medium bare wire as shown. The hook should be just large enough to fit around another piece of the same size of bare wire.

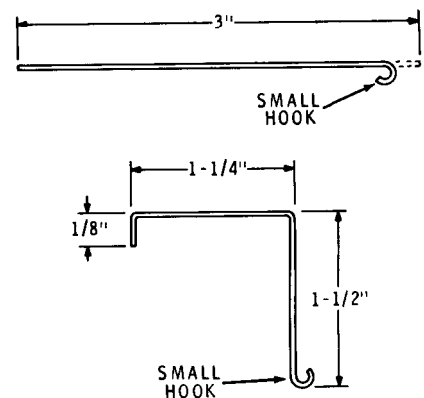

**Detail 4-12A**



- (✓) Refer to Detail 4-12B and connect the hook on the end of the formed wire through hole S to switch CZ, wafer B lug 6 (S-4). Connect the other end of this wire to relay K1 lug 5 (S-1) as shown in the Pictorial.

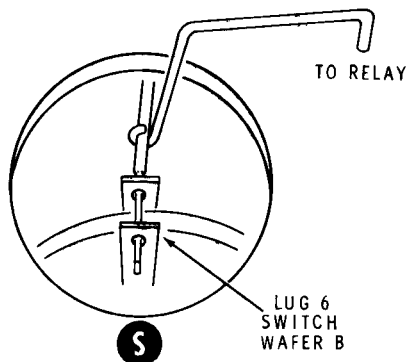

Detail 4-12B

- (✓) RFC6: Refer to Detail 4-12C and connect one lead of a 1 mH RF choke (#45-4) to solder lug CH (S-1). Wind the other lead around the bare wire coming from relay K1 lug 5 (S-1). Position the choke parallel to the chassis with a clearance of approximately 1/2".

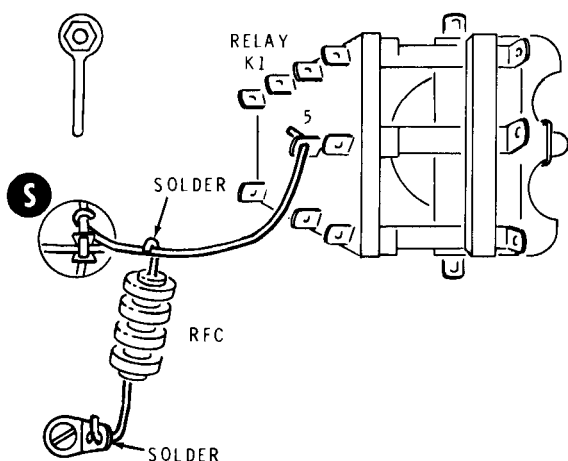

Detail 4-12C

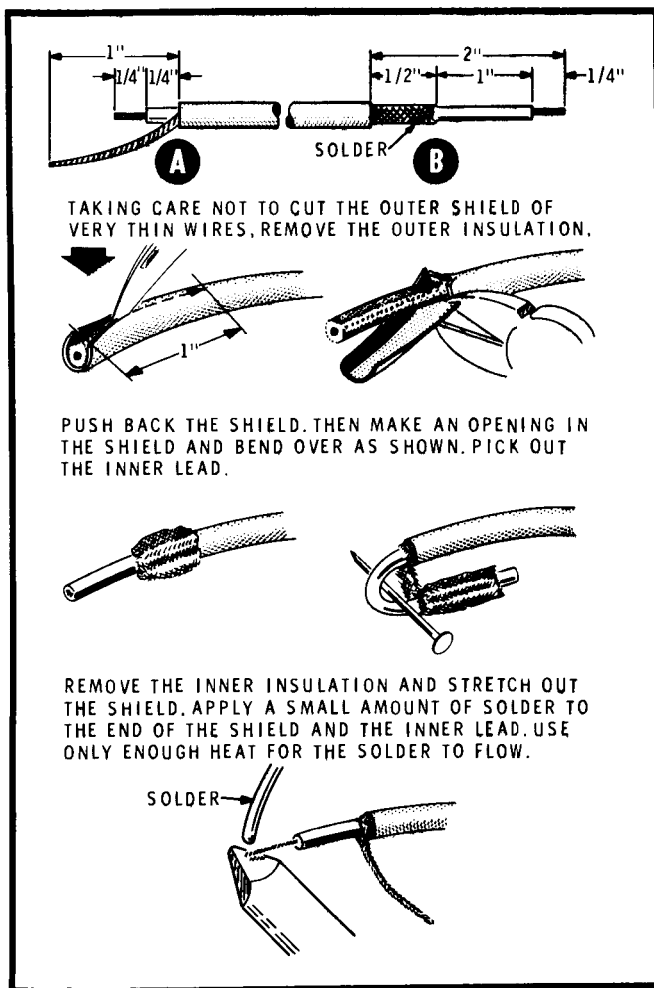

Detail 4-12D

Refer to Detail 4-12D for the next two steps.

- (✓) Prepare an 11-1/2" length of RG-58A/U coaxial cable. Tin the shield braid on end B. Use a minimum amount of heat to avoid melting the inner insulation.
- (✓) At end B of the 11-1/2" cable, connect the center conductor to relay K1 lug 7 (S-1).
- (✓) Locate the remaining coaxial cable coming from grommet T. Connect the center conductor of this cable to relay K1 lug 4 (S-1). Be sure this lead does not touch any other lug of the relay. NOTE: This is the cable coming from switch CZ, wafer A lug 7.

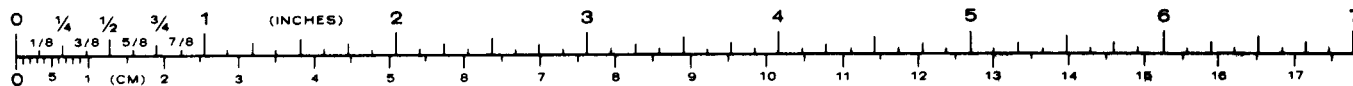

Booklet

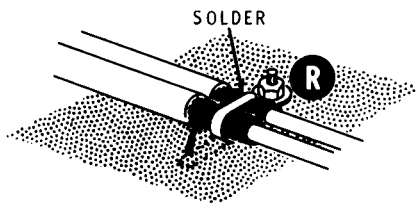

Detail 4-12E

- (✓) Refer to Detail 4-12E and position the prepared shields of the coaxial cables connected in the two preceding steps, over long solder lug R. Bend the solder lug back over both shield braids and solder. Use a minimum, but adequate, amount of heat.
- (✓) Connect the center conductor at the free end of the coaxial cable coming from relay K1 lug 7 to the center conductor of coaxial jack L (S-1). Connect the shield wires to phono socket U lug 2 (S-1).
- (✓) Cut two 1/4" pieces of small black sleeving.
- (✓) Cut both leads of a 100 kΩ resistor (brown-black-yellow) to 1/2".
- (✓) R27: Place a 1/4" sleeve on each resistor lead. Then connect the 100 kΩ resistor between relay K1 lugs 9 (S-2) and 3 (S-3) as shown in inset drawing 2 of the Pictorial.

Refer to Pictorial 4-13 (Illustration Booklet, Page 9) for the following steps.

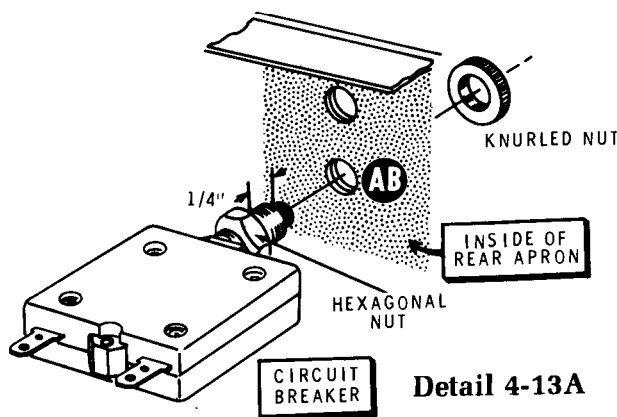

Detail 4-13A

Refer to Detail 4-13A for the following three steps.

- ( ) Remove a knurled nut from each of the two circuit breakers (#65-28).

- (✓) Position the face of each hexagonal nut 1/4" from the end of the mounting bushing.
- (✓) CB1: Mount a circuit breaker on the chassis rear apron at AB. Use the knurled nut provided. NOTE: For convenience in wiring, position the solder lugs to provide the maximum distance between the chassis and the lugs.

- (✓) CB2: In the same manner, mount the other circuit breaker at AA.

NOTE: In the following steps, you will connect the fan motor. Be careful not to tear the motor leads out of their plastic frame.

- (✓) Route one of the fan motor leads to terminal strip AE as shown. Connect the prepared lead to lug 2 of terminal strip AE (NS).
- (✓) Locate the remaining medium black stranded wire. Cut the wire to 8-1/2" and remove 1/4" of insulation from one end of the wire.

- ( ) Twist together (clockwise) the bare end of the black wire and the bare end of the fan motor lead. Then twist the wire nut **clockwise** onto the wire ends until it is tight. Make sure there are no bare wires exposed around the wire nut.

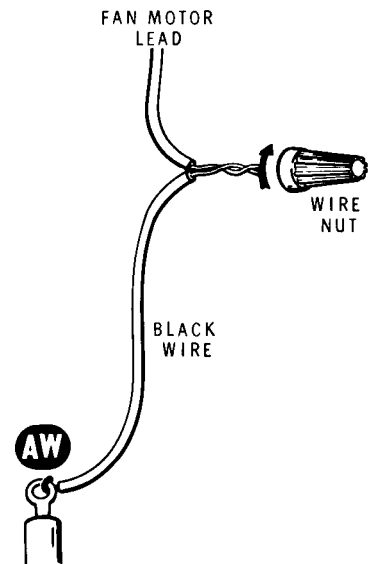

- (- ) Refer to Pictorial 4-13 and route the black wire to lug AW. Then cut the wire to the proper length. Prepare the wire end and then connect it to double lug AW (S-4).



NOTE: Make secure mechanical connections in each wiring step on this page.

Connect the wires from switches AN and Z as follows. If necessary, wrap a wire securely around a lug.

<u>Wire Coming from</u>	<u>Connect to</u>
(-/-) Lug 3, switch AN	Lug 2, terminal strip AE (S-2).
(✓) Lug 1, switch Z	Lug 1, circuit breaker AB (S-1).
(✓) Lug 2, switch Z	Lug 1, circuit breaker AA (S-1).

(✓) Prepare a 3-1/2" and a 4" large black stranded wire by cutting to length and removing 3/8" of insulation from each end of each wire.

(✓) Connect one end of the 3-1/2" wire to terminal strip AE lug 4 (S-1). Connect the other end of this wire to circuit breaker AB lug 2 (NS). Use the hole next to the circuit breaker body.

(✓) In the same manner, connect the 4" wire from terminal strip AE lug 1 (S-1) to circuit breaker AA lug 2 (NS).

(✓) Refer to Detail 4-13B and prepare the end of the line cord as shown. Remove 3/8" of insulation from the end of each of the three leads. Melt a small amount of solder on the end of each.

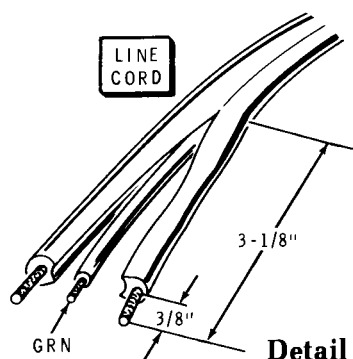

Detail 4-13B

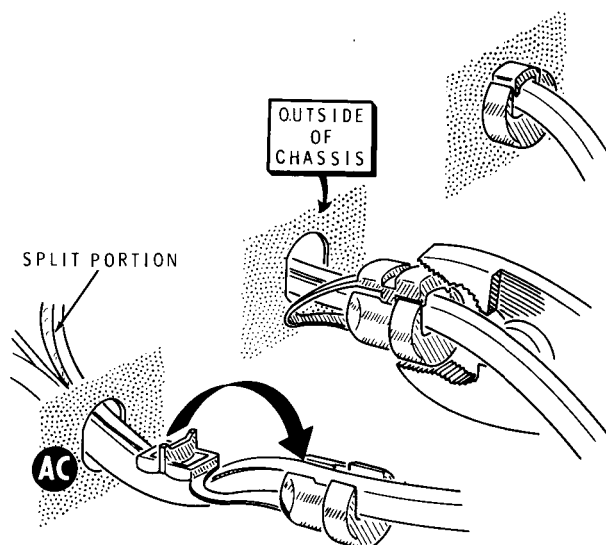

Detail 4-13C

(✓) Refer to Detail 4-13C and place the strain relief on the line cord just beyond the split portion of the cord, as shown. Use a pair of gas pliers to compress the strain relief, and then insert it into hole AC from the outside of the chassis.

(✓) Connect the green line cord wire to solder lug AX (S-1).

(✓) Connect one line cord lead to lug 2 of circuit breaker AB (NS).

(✓) Connect the other line cord lead to lug 2 of circuit breaker AA (NS).

(✓) C1: Connect a .005  $\mu$ F (#21-72) ceramic capacitor from the solder lug at AE (NS) to circuit breaker AB lug 2 (S-3).

(✓) C2: Connect a .005  $\mu$ F (#21-72) ceramic capacitor from the solder lug at AE (S-2) to circuit breaker AA lug 2 (S-3).

IMPORTANT: Recheck all the wiring steps on this page; work each wire connection with pliers to be certain that all the wires and leads at each connection are firmly soldered. Reheat any doubtful connection and add a little more solder if necessary.





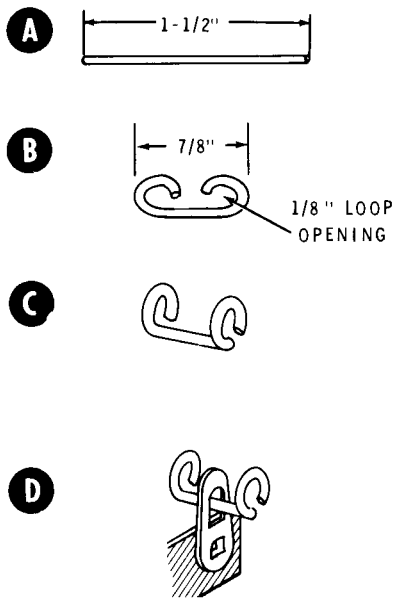

Detail 4-13D

Refer to Detail 4-13D for the following steps.

- (✓) **Part A.** Cut a 1-1/2" length of medium bare wire.
- (✓) **Part B.** On each end of the bare wire, form a loop having an inside diameter of approximately 1/8". Adjust the size of the loops so they will just slide onto the tinned end of one of the large green transformer leads from hole AH.
- (✓) **Part C.** Bend the two wire loops up as shown.
- (✓) **Part D.** Pass the formed wire through lug 1 of terminal strip P.
- (✓) Form another bare wire in the same manner, except pass this wire through lug 3 of terminal strip P.

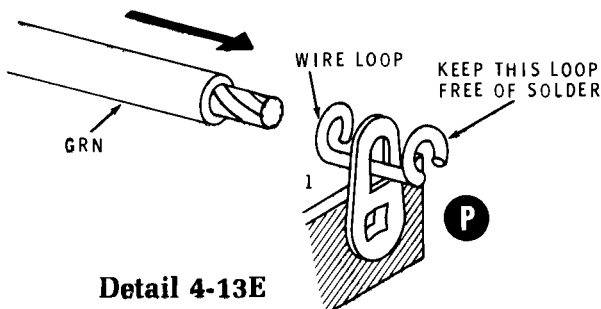

Detail 4-13E

- (✓) Refer to Detail 4-13E and position the wire loops at lug 1 of the terminal strip so they point up away from the chassis. Then insert the end of the 6-1/2" green lead from hole AH all the way into the wire loop. Be careful to keep the two wire loops equally distant from the terminal strip solder lug. Then use pliers to compress the wire loop on the green wire. Solder the green lead to the wire loop and the wire loop to the solder lug, but be sure to keep the other wire loop free of solder. Also solder the lead from the .02 μF disc capacitor and the brown wire to lug 1 at this time.
- (✓) Repeat the preceding step at lug 3 of terminal strip P for the 5-3/4" green lead.

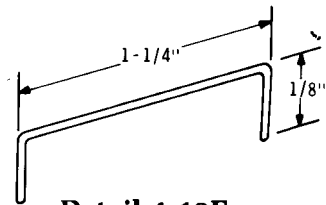

Detail 4-13F

- (✓) Refer to Detail 4-13F and form two 1-1/2" lengths of medium bare wire. Then, fit one wire from lug 1 of tube socket D (S-1) to lug 5 of tube socket N (NS).
- (✓) Fit the other 1-1/2" wire from lug 5 of tube socket D (S-1) to lug 1 of tube socket N (NS).
- (✓) C21: Connect a .02 μF disc capacitor between tube socket N lugs 5 (S-2) and 1 (NS).
- (✓) C32: Connect a .01 μF (#21-70) disc capacitor from tube socket N lug 1 (S-3) to terminal strip AG lug 1 (S-2).

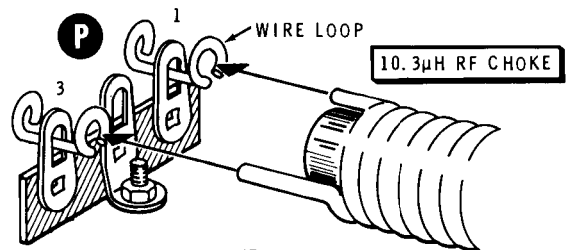

Detail 4-13G

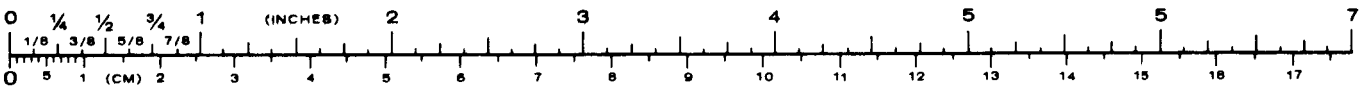



- Refer to Detail 4-13G and fit the 10.3  $\mu$ H RF choke (#45-78) so the two short leads at one end fit into the two wire loops on terminal strip P. At the other end of the choke, form the two leads so they loop around the bare wire filament leads between the two tubes as shown. Make sure the RF choke leads clear the chassis by at least 1/8". Solder the four RF choke leads carefully as these leads carry heavy current.

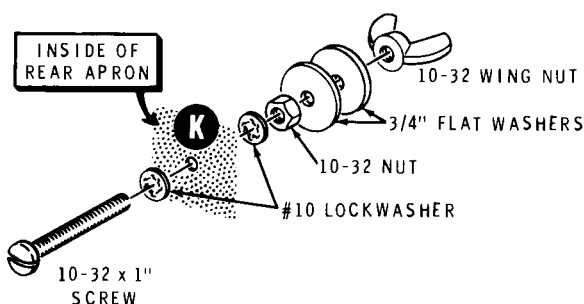

Detail 4-13H

- Refer to Detail 4-13H and install the ground post at K on the chassis rear apron. Use a 10-32 x 1" screw, two #10 lockwashers, a 10-32 nut, two 3/4" flat washers, and a 10-32 wing nut.

Refer to Pictorial 4-14 (Illustration Booklet, Page 10) for the following steps.

- Refer to Detail 4-14A and install an angle bracket (#204-1041) on the chassis at AS and AT. Use 6-32 x 3/8" flat head hardware.

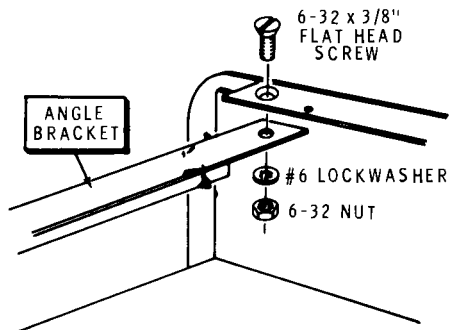

Detail 4-14A

- In the same manner, install the other angle bracket between AP and AR.
- Refer to Detail 4-14B and pass a cable tie (#354-5) around all of the wires at each of the six points shown in the Pictorial to form a neat cable. Equalize any slack in each wire between the ends of the wire. Then pull each cable tie snug and clip off the excess length of the tie.

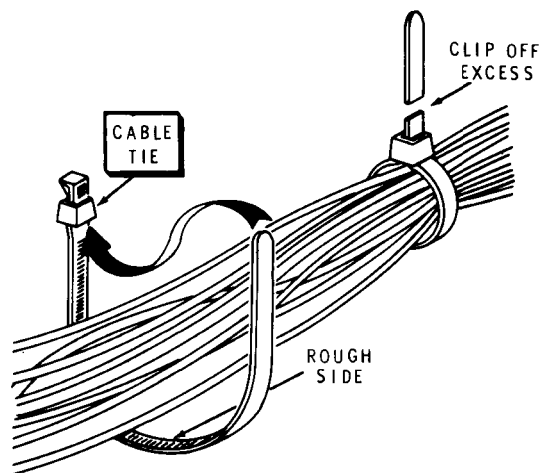

Detail 4-14B

120-240 VOLT WIRING

NOTE: Before you perform the next two steps, we suggest that you read "Power Considerations" on Page 74.

This Amplifier can be operated from 120 or 240 volts, 50/60 Hertz, alternating current.

Make the proper connections on terminal strip AE for the supply voltage you will use. Refer to the inset drawing of Pictorial 4-14 and perform one of the following steps, depending on the line voltage to be used.

- 120
  - For 120 VAC operation, connect a 1-3/8" medium bare wire between terminals 1 and 2 and another bare wire between terminals 3 and 4 of terminal strip AE.
- For 240 VAC operation, connect a 1-3/8" medium bare wire between terminals 2 and 3 of terminal strip AE.

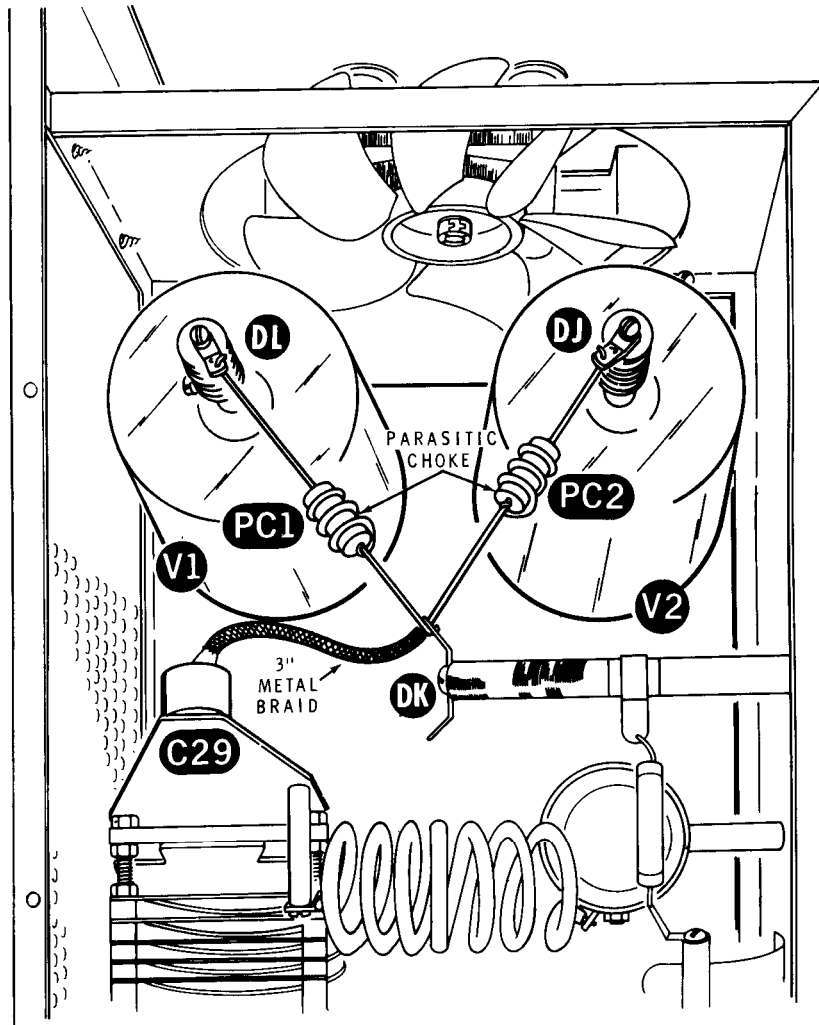

PICTORIAL 4-15

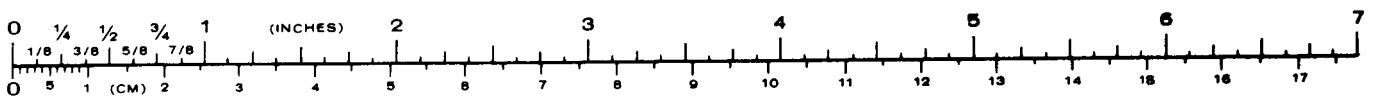

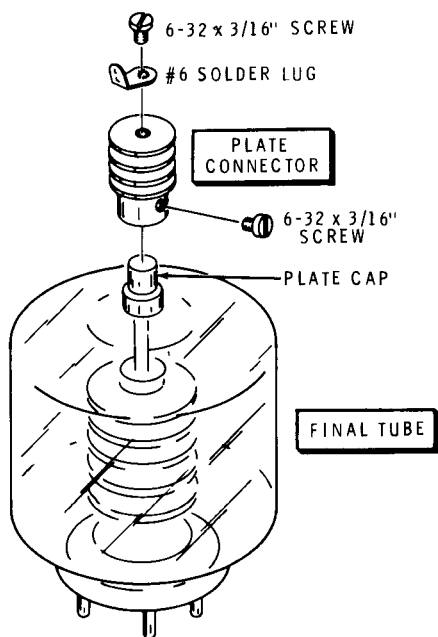

Detail 4-15A

**FINAL TOP-CHASSIS WIRING**

Refer to Pictorial 4-15 for the following steps.

Refer to Detail 4-15A for the following three steps.

- (✓) Loosely install a #6 solder lug on the top end of each plate connector (#260-12) with a 6-32 x 3/16" screw.
- (✓) Start a 6-32 x 3/16" screw into the side of each plate connector.
- (✓) Place each plate connector on the plate cap of a final tube (3-500Z) and tighten the screw on the side of each connector.
- (✓) V1, V2: Place a final tube in each tube socket. CAUTION: Use extreme care when you install a final tube (3-500Z). Without rocking, gently push the tube into its socket. Too much pressure or lateral force (from rocking) may crack the glass beads around the socket pins, and damage the tube. Heath Company cannot be held responsible for any damage sustained through improper installation.

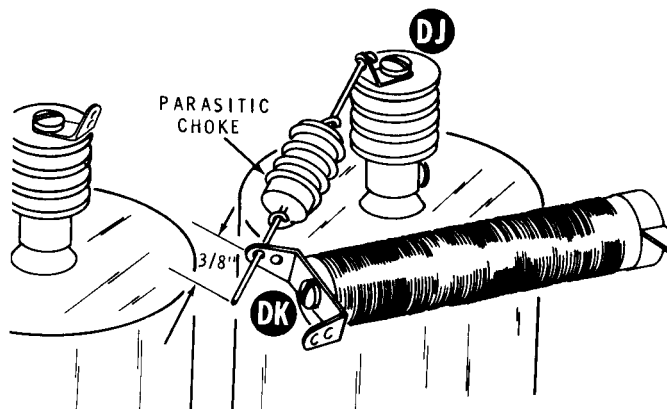

Detail 4-15B

NOTE: When you install parasitic chokes in the following steps, center the chokes between the solder lugs.

- (✓) Cut each lead of the two parasitic chokes (#45-53) to a length of 7/8".
- (✓) PC2: Refer to Detail 4-15B and install a parasitic choke from solder lug DJ (S-1) to solder lug DK (NS). Note that the lead of the parasitic choke extends through solder lug DK for approximately 3/8". Leave this lead straight as shown in the Detail.
- (✓) PC1: Install the remaining parasitic choke from solder lug DL (S-1) to solder lug DK (NS).
- (✓) Tighten the screws in the tops of the two plate connectors.
- ( ) Refer to Detail 4-15C and open up the ends of a 3" length of metal braid with a pencil. (Note that the metal braid is actually flattened tubular braid.) Push one end onto the 3/8" projecting end of parasitic choke PC2 (S-3). Push the other end over the solder lug on capacitor C29 (S-1).

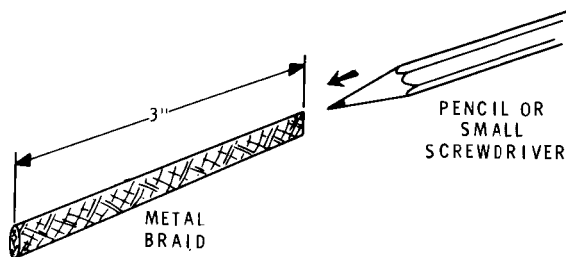

Detail 4-15C

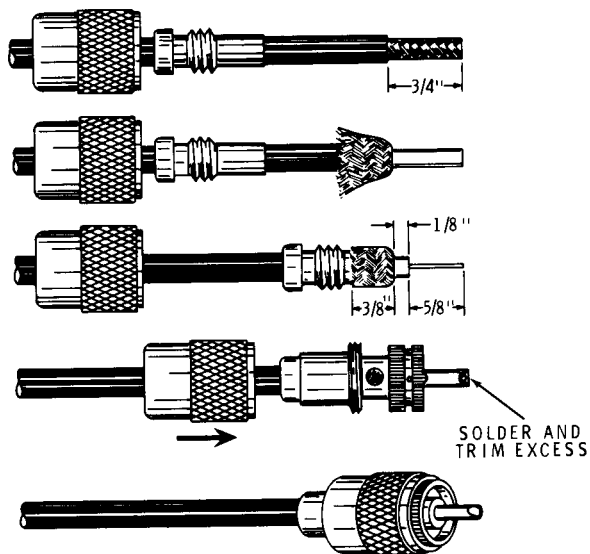

PICTORIAL 4-16

**CABLE PREPARATION**

- ( ) Cut a length of RG-58A/U coaxial cable which will conveniently reach from the output of your exciter to the RF Input connector on the rear panel of the Amplifier (4' maximum recommended).
- ( ) Refer to Pictorial 4-16 and install a coaxial plug (#438-9) and a coaxial plug insert (#438-12) on one end of the coaxial cable.
- ( ) On the other end of the coaxial cable, install a connector (not furnished) which will mate with the output connector of your exciter. Refer to Pictorial 4-16 or Pictorial 4-17, as appropriate.

Lay the cable aside for use later.

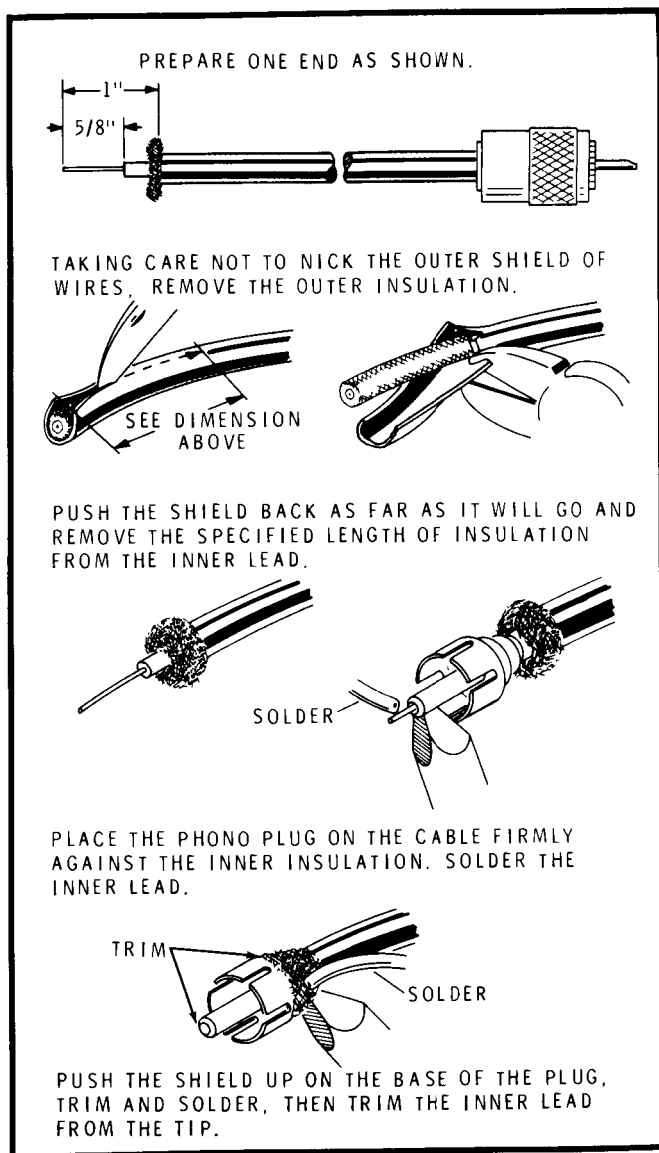

PICTORIAL 4-17

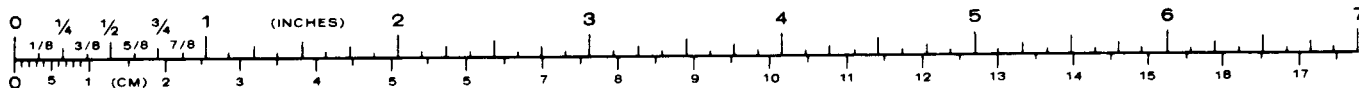

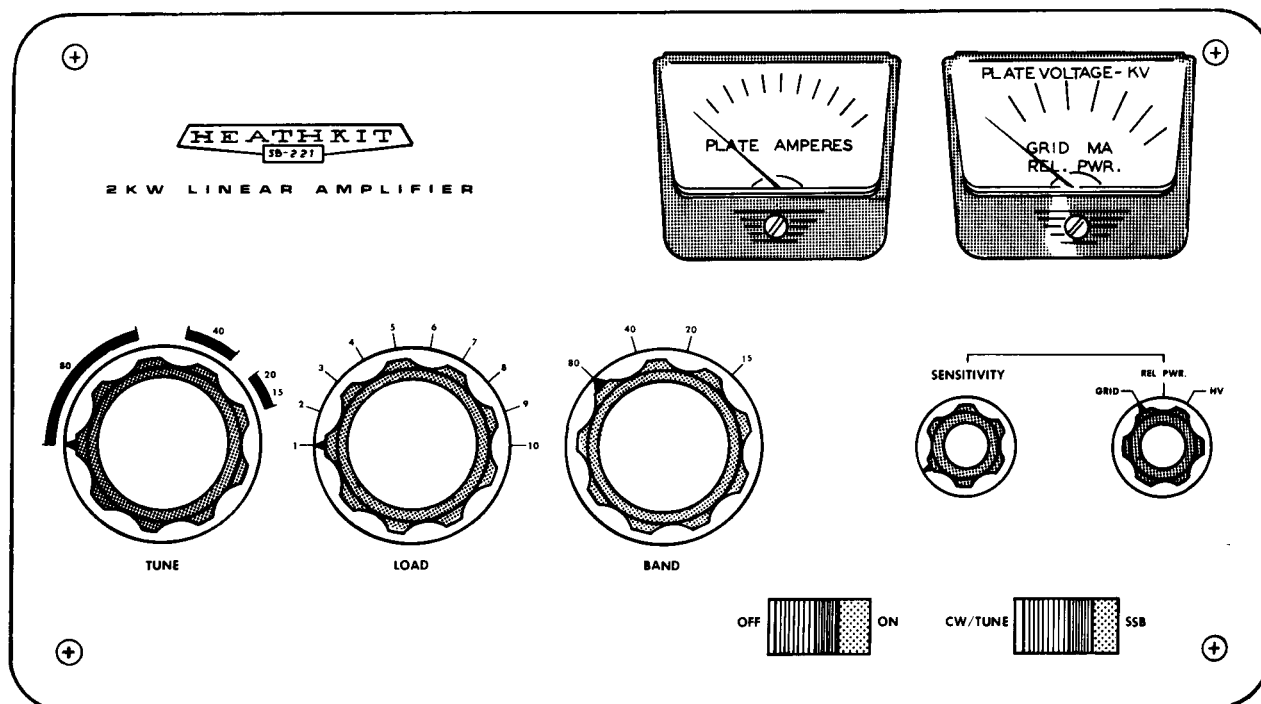

PICTORIAL 4-18

## KNOB INSTALLATION

Refer to Pictorial 4-18 for the following steps.

- ( ) Refer to Detail 4-18A and start two 8-32  $\times$  1/4" setscrews into each of the three large knobs. Start a single setscrew into each of the two small knobs.
- ( ) Turn the shafts of the Tune and Load capacitors so the plates are fully meshed.
- ( ) Turn the three other shafts fully counterclockwise.
- ( ) Install the knobs on the shafts so the index marks are positioned as shown in the Pictorial, and tighten the setscrews.

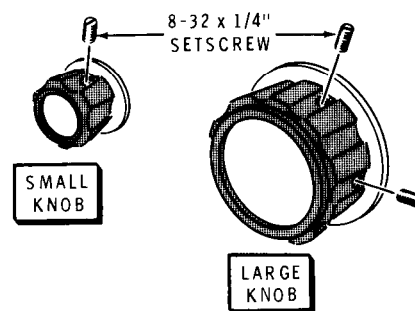

Detail 4-18A

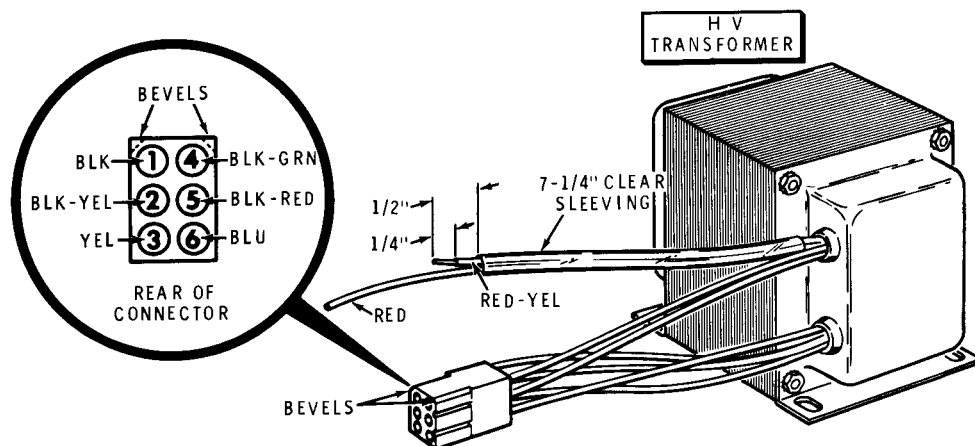

PICTORIAL 4-19

**HIGH VOLTAGE (HV) TRANSFORMER INSTALLATION**

Refer to Pictorial 4-19 for the following steps.

- (→) Cut the following HV transformer leads to 7". Measure the leads from the point where they exit the transformer. **Do not shorten the red and red-yellow leads.**

Black	Black-Green
Black-Yellow	Black-Red
Yellow	Blue

- (→) Remove 1/4" of insulation from the end of each of the 7" long transformer leads. Then twist the fine wire strands together and melt a **small** amount of solder on each bared end.

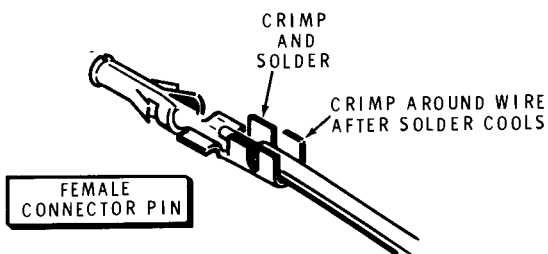

Detail 4-19A

- (✓) Refer to Detail 4-19A and install female connector pins (#432-982) on one end of each of the 7" long transformer leads. **Do not install connectors on the red and red-yellow transformer leads.**

Position the plug shell as shown in the Pictorial (note the position of the slots and beveled corners). Then push the connector pins on the transformer leads into the holes of the plug shell as follows. Make sure each pin locks into place.

- (✓) Black into hole 1.
- (✓) Black-yellow into hole 2.
- (✓) Yellow into hole 3.
- (✓) Black-green into hole 4.
- (✓) Black-red into hole 5.
- (✓) Blue into hole 6.

**NOTE:** Be sure to use the **small** clear sleeving in the next step.

- (✓) Pass a 7-1/4" length of small clear sleeving over the red and the red-yellow leads coming from the HV transformer. Slide the sleeving on the leads as far as it will go.
- (✓) Cut off the red-yellow lead 1/2" beyond the end of the sleeving. Remove 1/4" of insulation. Do not shorten the red transformer lead.

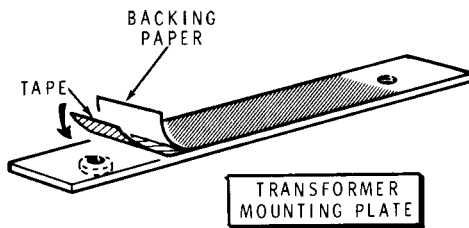

Detail 4-20A

Refer to Pictorial 4-20 (Illustration Booklet, Page 10) for the following steps.

- (1) Cut two 4" lengths of double-sided sticky tape.
- (2) Carefully peel the backing paper from one side of each length of tape. Refer to Detail 4-20A and press a length of tape on each of the transformer mounting plates as shown. Then carefully peel the backing paper from the other side of the tape.
- (3) Refer to Detail 4-20B (Illustration Booklet, Page 11) and press the transformer mounting plates to the bottom of the chassis as shown. Make sure the nuts line up with the holes in the chassis.

NOTE: When you perform the next step, use the length of large clear sleeving to hold the 10-32 screws until you get them started. (See the inset drawing on the Pictorial).

- (4) T1: Refer to Detail 4-20B (Illustration Booklet, Page 11) and mount the HV transformer to the chassis. Be sure to mount the transformer so the leads are positioned as shown. Use four 10-32  $\times$  1/2" screws.
- (5) Match the beveled corners of the plug, coming from the transformer, with the beveled corners on socket Y. Then push the plug into the socket as far as possible.
- (6) Route the remaining two transformer wires as shown in the Pictorial. Then connect the red-yellow lead to the positive lug of capacitor C14 (S-3).

NOTE: In the following steps, if solder on the bare end of the red lead prevents it from entering hole D of the circuit board, carefully cut off just enough of the soldered lead end to allow it to fit into the hole. Be careful not to cut the lead too short.

- (7) Connect the red lead coming from the HV transformer to circuit board hole D (S-1). Reach in between the circuit board and the capacitor bracket to solder this connection. Make sure this connection is well soldered.

This completes the "Step-by-Step Assembly" section. Carefully inspect all connections for loose wires or unsoldered connections. Remove any wire clippings or solder splashes. Then proceed to "Test and Final Assembly."

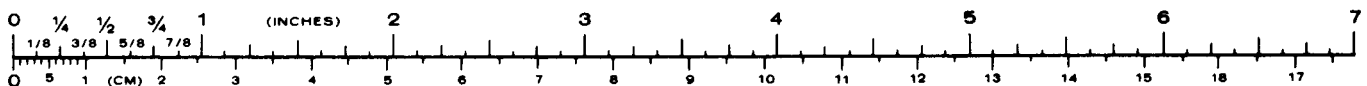



## TEST AND FINAL ASSEMBLY

*Remove meter jumpers*

The input coils are factory adjusted and do not require any further alignment.

The brass spring and the metal spacer form a safety "interlock" which grounds the high voltage power supply and removes the high voltage from points which are exposed when the perforated cover is removed.

Refer to the chassis photographs for the location of the interlock and the resistance test points.

### RESISTANCE CHECK

- ( ) **IMPORTANT:** Refer to Pictorial 5-1, push down the brass spring of the interlock, and temporarily insert a rubber foot between the brass spring and the metal spacer. If you fail to do this, the high voltage circuit will be short-circuited, you will be unable to obtain a plate connector resistance reading, and damage will result if power is applied.
- ( ) The resistance between the plate connectors and the chassis should measure approximately 200 k $\Omega$  after the meter stabilizes.
- ( ) The resistance between lugs 2, 3, and 4 of each tube socket and the chassis (Pictorial 4-14 Illustration Booklet, Page 10) should measure approximately 20  $\Omega$ .

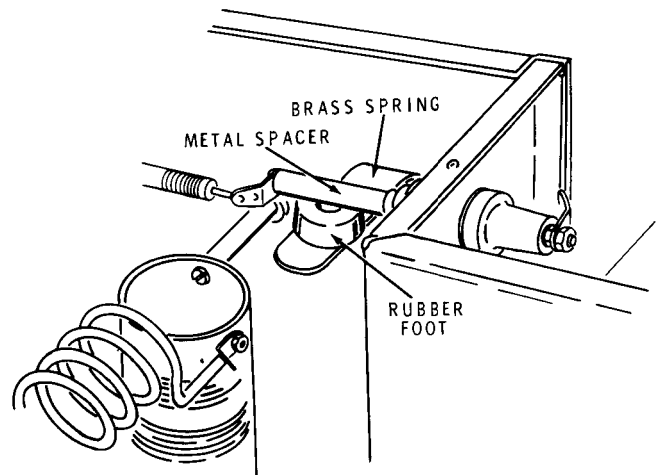

**PICTORIAL 5-1**

If any difficulty is encountered in obtaining either of these resistance readings, refer to the "In Case of Difficulty" section of the Manual on Page 82.

- ( ) Remove the rubber foot from the interlock.

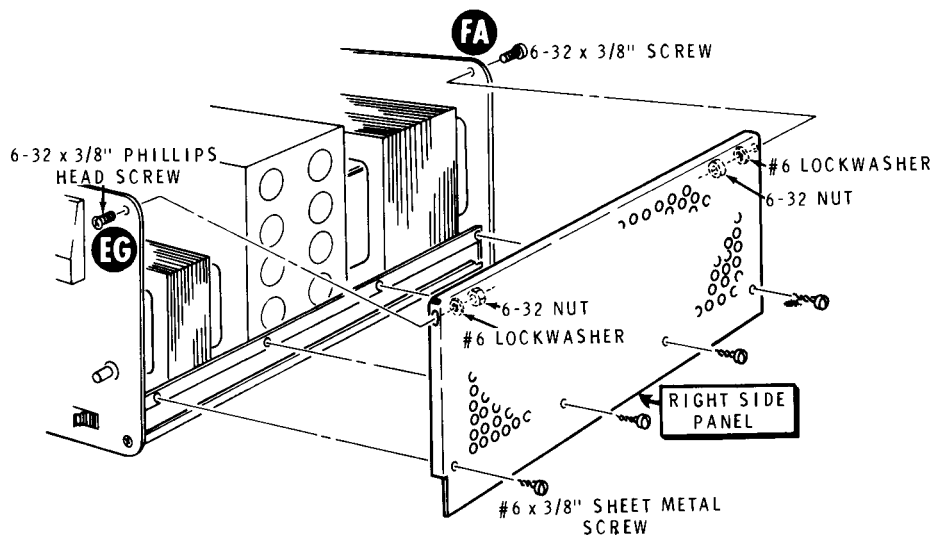

Detail 5-2A

Refer to Pictorial 5-2 (Illustration Booklet, Page 11) for the following steps.

- ( ) Refer to Detail 5-2A and install the right side panel. Use #6 x 3/8" sheet metal screws along the lower edge, 6-32 x 3/8" hardware at EG and FA. CAUTION: After the panel is installed, check to make sure there is at least 1/4" clearance between the point of the sheet metal screw and any connections to the positive (+) lug of filter capacitor C10. (See Pictorial 4-7, Illustration Booklet, Page 7).
- ( ) As shown in the Pictorial, place the perforated top cover (#205-724) on the top of the Amplifier with the lip against the front panel pointing down. Align the mounting screw holes. Then mark the hole in the cover which is directly over that portion of the brass spring which protrudes beyond the metal spacer.
- ( ) Refer to Detail 5-2B and install a 6-32 x 1-1/4" tapped phenolic spacer (#255-39) on the underside of the perforated cover at the marked hole. Use a 6-32 x 3/8" screw.

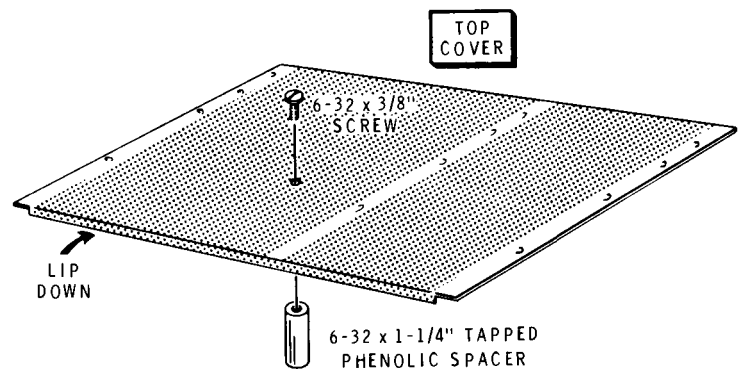

Detail 5-2B

- ( ) Install the perforated top cover and the top rear plate cover (#205-723) on the top of the amplifier. Use #6 x 3/8" sheet metal screws. First, install a screw near each corner of the top cover and then check visually to make sure that the phenolic spacer on the under side of the top cover pushes the interlock spring down away from the metal spacer mounted on the feed-through insulator. Any required repositioning of the phenolic spacer should be accomplished before completing the top cover installation. Then install the rest of the sheet metal screws.
- ( ) If necessary, adjust each meter pointer to "0" with the meter adjusting screw (see Pictorial 6-1 Illustration Booklet, Page 12).

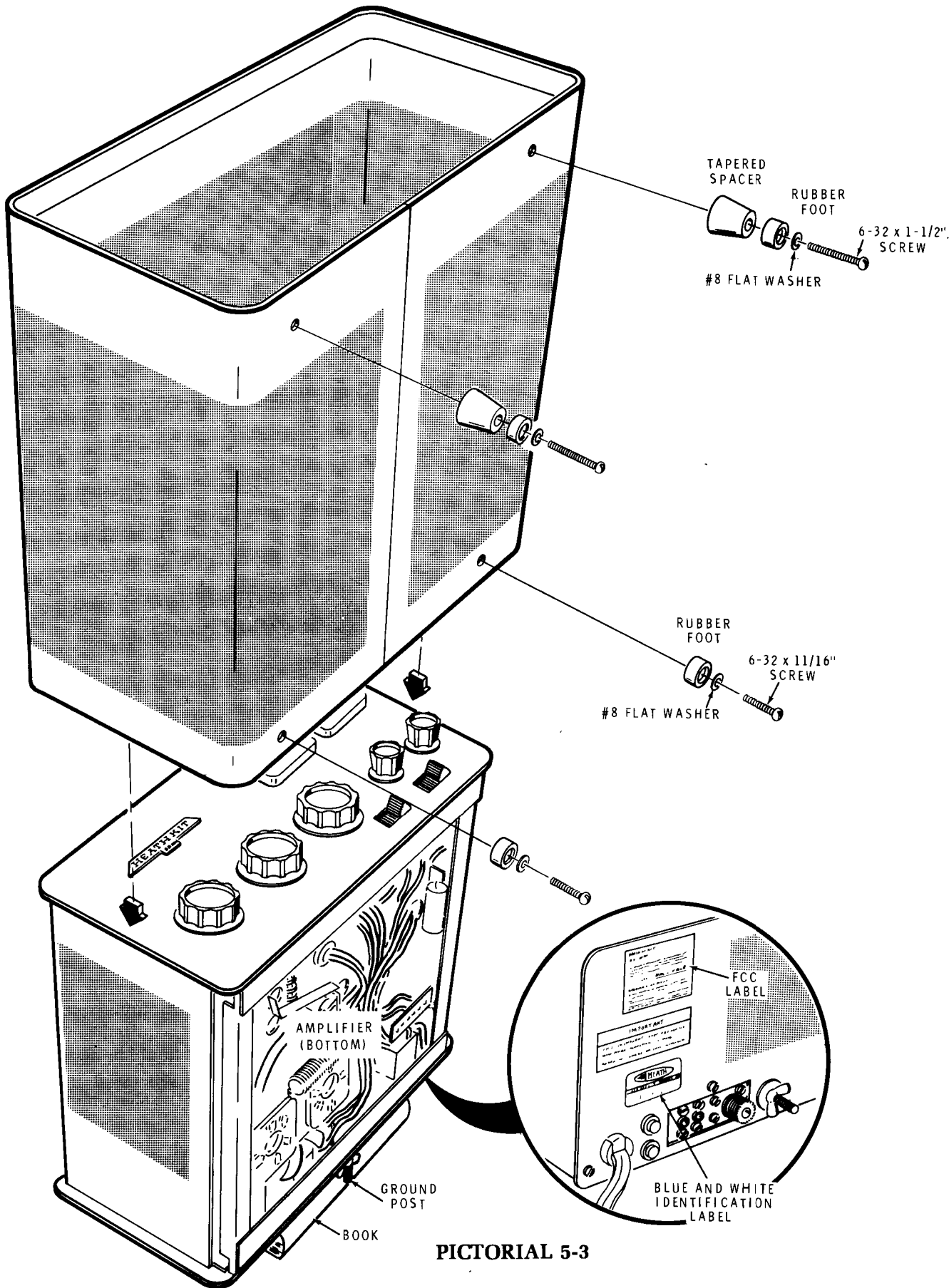

PICTORIAL 5-3



NOTE: If at any time during the testing and operation the Linear Amplifier does not perform as described, unplug the Linear Amplifier line cord and refer to the "In Case of Difficulty" section of the Manual.

Position the switches and controls as follows:

TUNE	9 o'clock
LOAD	9 o'clock
BAND	Any
SENSITIVITY	12 o'clock
METER SWITCH	HV
POWER SWITCH	OFF
MODE SWITCH	CW/TUNE

- ( ) Plug the line cord into the power source for which the unit is wired, either 120 volts or 240 volts AC.

**CAUTION: LETHAL VOLTAGES ARE PRESENT IN THIS UNIT. USE EXTREME CARE WHEN MAKING ANY TESTS.**

- ( ) Push the POWER switch to ON.
- ( ) Check to see that the tube filaments and meter pilot lamps light, and that the fan operates. The right-hand meter should read approximately 2500 volts, depending on your line voltage.
- ( ) Push the MODE switch to SSB. The meter should read approximately 3000 volts, depending on your line voltage.

NOTE: There should be no indication on either panel meter except when the METER SWITCH is at the HV position.

- ( ) Push the POWER switch to OFF and unplug the line cord.

NOTE: Read through the following steps and decide whether you want your amplifier to sit level, or whether you wish the front of the chassis elevated. Then select the feet and mounting hardware so the parts will be immediately available as you install the cabinet. The screws for the mounting feet will be inserted through the four holes in the cabinet bottom and screwed into the captive nuts in the flange of the chassis.

Refer to Pictorial 5-3 for the following steps.

- ( ) Place a book on a flat surface and balance the amplifier chassis on the book, front panel up-most.
- ( ) Lower the cabinet onto the chassis so the captive nuts in the chassis bottom flange are aligned with the four holes in the cabinet.

Perform only **one** of the following two steps, depending upon how you wish the amplifier cabinet positioned.

- ( ) If you wish to have the amplifier cabinet sit level, install a rubber foot at each corner of the cabinet. Use 6-32 × 11/16" screws and #8 flat washers.
- ( ) If you wish the front of the cabinet to be elevated, install a rubber foot on each rear corner with 6-32 × 11/16" screws. Then, install a tapered spacer and a rubber foot at each front corner of the cabinet with 6-32 × 1-1/2" screws. Use a #8 flat washer on each screw.

NOTE: The blue and white identification label shows the Model Number of your kit. Refer to these numbers if any communications with the Heath Company.

- ( ) Remove the paper backing from the blue and white label. Then press the label onto the rear panel, just above the line cord, as shown in the inset drawing on Pictorial 5-3.

- ( ) Prepare the following FCC label as follows:

At the bottom of the label, fill in the required information: Sign your name, put in today's date, your call sign issued by the FCC, your class of license (General, Advanced, or Extra) and the expiration date on the license.

- ( ) Remove the paper backing from the FCC label and press it onto the rear panel in the open area shown.

NOTE: If it ever becomes necessary to return your Amplifier to the Heath Company for service, refer to "Special Shipping Instructions" on Page 84.

This completes the assembly of your Linear Amplifier. Proceed to "Installation."

# INSTALLATION

## LOCATION

Do not operate the Amplifier in excessively warm locations or near heating vents or radiators. Be sure air can circulate freely around and through the amplifier cabinet; and provide an unobstructed air inlet for the blower. Do not place any books, magazines, or equipment on top of the cabinet to impede the free flow of air.

## POWER CONSIDERATIONS

Because of the power involved, this Amplifier should preferably be served by its own 240 VAC electric service line, having three 12 gauge conductors and fused in each "hot" wire for 10 amperes. However, if a single 240 VAC line must serve the entire station, make an effort to connect your equipment so the load will be balanced between the two "hot" wires as nearly as possible.

If only 120 VAC can be provided, use a separate line having 10 gauge conductors and 20-ampere fuses.

DO NOT use this Amplifier at its full ratings on a regular house wiring circuit, as the ratings of the wire will almost certainly be exceeded.

Avoid excessively long runs of wire from your service entrance. A heavy flow of current in such a line results in a voltage drop which can affect the performance of your equipment.

The plug on the power cord for this kit is for standard 120 VAC outlets. For 240 VAC operation in the U.S.A., cut off and replace this plug with a permanent plug that matches your 240 VAC receptacle in a manner such that your power connection conforms with section 210-21 (b) of the National Electric Code, which reads, in part:

"Receptacles connected to circuits having different voltage, frequencies, or types of current (AC or DC) on the same premises shall be of such design that attachment plugs used on such circuits are not interchangeable."

**When you install the new plug, make sure it is connected according to your local electrical code. Keep in mind that the green line cord wire is connected to the amplifier chassis.**

For your convenience in identifying conductors, one edge of the heavy line cord is beaded. The other edge is smooth.

## ANTENNA

The output circuit of the Amplifier is designed for connection to an unbalanced transmission line of 50  $\Omega$  characteristic impedance. Lines of other characteristic impedance may be used providing the SWR (standing wave ratio) does not exceed 2:1.

The antenna connector is a UHF type SO-239. A mating PL-259 plug is furnished for your transmission line. See "Equipment Interconnections" for information on how to install this plug.

Coaxial cables RG-8/U, RG-11/U, or similar types, should be used for the transmission line. The smaller types RG-58/U and RG-59/U are not recommended because of the power level.

The "A.R.R.L. Antenna Book" is commonly available and includes comprehensive reference work on transmission lines and antennas. Other similar handbooks for the amateur are offered for sale and can often be found in a public library.

## GROUNDING

Connect a good earth or water pipe ground to the ground post on the rear panel of the Amplifier. Use the heaviest and shortest connection possible.

Before you use a water pipe ground, inspect the connections around your water meter and make sure that no plastic or rubber hose connections are used which interrupt electrical continuity to the water supply line. Install a jumper around any insulating water connectors found. Use heavy copper wire and pipe



clamps. It is best to ground all equipment to one point at the operating position and then ground this point as discussed above.

## EQUIPMENT INTERCONNECTIONS

Interconnections between this Amplifier and other Heath equipment are shown in the Pictorial 7- series of illustrations (Illustration Booklet, Pages 13 through 15). Other makes of equipment will usually follow the same general pattern.

## CABLES FURNISHED

Two phono cables are furnished. These are shielded cables which have a phono plug molded at each end. Use one cable to connect the amplifier ALC output to the exciter ALC input. Use the second cable to connect the amplifier antenna relay socket to the exciter antenna relay socket.

An RG-58A/U coaxial cable was made up earlier. This cable is used to connect the exciter RF output to the amplifier RF input.

## ANTENNA RELAY

### OPERATION

The antenna relay circuit in the Amplifier must be grounded in the transmit mode. Heath exciters contain a provision to accomplish this action. If a relay terminal, or other switching provision is not available, this function must be provided by other means. If you have a separate coaxial send-receive relay in your station, it may have external contacts available. A separate switch can also be used.

## HEATH TRANSCEIVERS WITH 11-PIN POWER PLUGS

If you will use your Amplifier with a Heath transceiver which has an 11-pin power plug on the rear panel, refer to Pictorial 8-1 (Illustration Booklet, Page 15) and perform the following steps to accomplish the antenna relay connection.

However, if you have previously changed the interior wiring of the transceiver to use one of the spare phono sockets to bring out the exterior antenna relay connection, disregard the following steps and proceed to the "Operations" section.

- ( ) Cut off and discard the phono plug from one end **only** of one of the phono cables furnished.

- ( ) Remove 3/4" of the gray outer insulation of the cable.
- ( ) Unwind the shield wires from the inner insulation. Then twist the shield wires tightly together and melt a **small** amount of solder on the ends of the wires.
- ( ) Remove 1/4" of insulation from the inner conductor, twist the exposed bare wires tightly, and melt a **small** amount of solder on the wire ends.

## Model HW-101 Transceiver

NOTE: Perform the following steps if you intend to use your Linear Amplifier with a Heathkit Model HW-101 Transceiver.

- ( ) Remove the transceiver power cable socket cap and slide it back on the power cable. Then push the prepared end of the phono cable through the socket cap as shown in the Pictorial.

NOTE: When you solder the power socket in the following steps, be very careful that you do not get the hot soldering iron against the clear sleeving already installed on the adjacent lugs.

- ( ) Connect the center conductor of the phono cable to lug 11 (S-1) and the shield wires to lug 5 (S-1) of the power socket. Use 1/2" sleeving on the shield wires.
- ( ) Snap the power socket cap back into place.

## Model SB-104A Transceiver

NOTE: Perform the following steps if you intend to use your Linear Amplifier with the Heathkit Model SB-104A Transceiver.

- ( ) Remove the transceiver accessory socket cap. Then push the prepared end of the phono cable through the socket cap as shown in the Pictorial.
- ( ) Connect the center conductor of the phono cable to lug 8 (S-1) and the shield wires to lug 9 (S-1) of the accessory socket. Use 1/2" sleeving on the shield wires.
- ( ) Snap the accessory socket cap back into place.

# OPERATION

## CONTROLS, CONNECTORS, AND METERS

Refer to Pictorial 6-1 (Illustration Booklet, Page 12) for identification of the front panel controls and a concise description of the functions of each.

Refer to Pictorial 6-2 (Illustration Booklet, Page 12) for rear panel connections.

### READING THE METER

Refer to Pictorial 6-3 for illustrations of the two panel meters.

#### Plate Meter

The Plate Meter is calibrated from 0 to 1 ampere. Note that by adding the proper number of zeros and dropping the decimal point, each scale number may be read as milliamperes. Thus .5 amperes would become 500 milliamperes.

#### Multi-Meter

Read the Multi-Meter scale which corresponds to the setting of the METER SWITCH:

METER SWITCH POSITION	MEASURES	SCALE READING
GRID	Grid current	0-350 milliamperes (lower scale)
REL PWR	Relative power output	0-350 (lower scale) (Adjust needle deflection to full scale with SENSITIVITY control after tune-up)
HV	High voltage	0-3.5 kilovolts (upper scale)

*Remove meter jumpers*

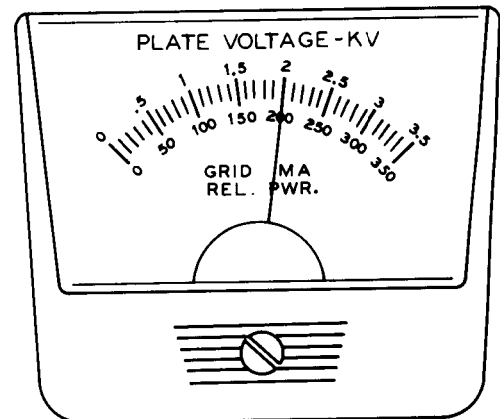
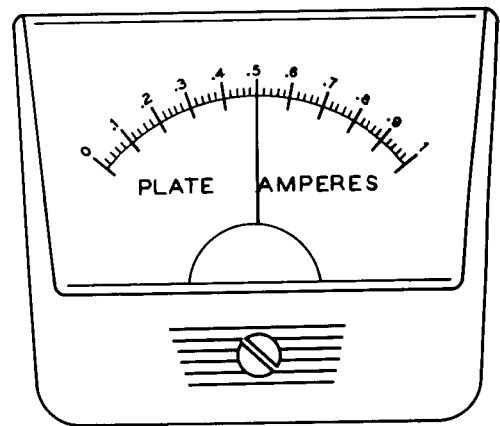

PICTORIAL 6-3



## GENERAL

### SAFETY INTERLOCK

Refer to the Chassis Photograph (Page 92) for the location of the interlock. When the amplifier top cover is in place, the insulator on the underside of the cover opens the interlock and the high voltage circuit is operational. When the top cover is removed, the interlock closes and connects the high voltage circuit to chassis. This connection will discharge the filter capacitor bank and eliminate a shock hazard.

**WARNING:** If the Amplifier is turned ON when the amplifier cover is removed, the high voltage power supply will be short circuited and may be damaged. If this occurs, DO NOT touch any part of the high voltage supply with your hands until all possible high voltage points have been checked with a separate voltmeter.

### CIRCUIT BREAKERS

Push in the red buttons on the two circuit breakers and note their position. When a circuit breaker opens, the red buttons will protrude farther and will be easily noticed.

If one or both circuit breakers open during operation of the Amplifier, turn the amplifier POWER switch OFF; then push the red buttons in to their former position, wait a few seconds, and push the POWER switch to ON. If the breakers will not stay closed, push the POWER switch OFF, unplug the line cord, and locate the reason for the overload.

### TUBES

The Amplifier uses "instant heating" type tubes. Therefore, after tune-up, you can use the Amplifier immediately after it is turned on.

It is not abnormal for the tube plates to show a dull red color. If the plates show a bright orange or yellow color, tuning and drive conditions should be investigated immediately, and necessary corrections should be made.

After prolonged operation, let the Amplifier run for several minutes without excitation so the fan will cool the tubes before the Amplifier is turned off.

### DC INPUT POWER

In grounded grid amplifier operation, a considerable portion of the driving power is fed through the amplifier tube. The Amplifier output is the approximate sum of the driver output and the power added by the Amplifier. Both the driver and Amplifier input powers must therefore be considered when calculating DC input power.

### DRIVING POWER

This Amplifier is designed to operate at full ratings (see "Specifications") when driven by an exciter delivering approximately 100 watts of RF output. An exciter of lower power output may be used as a driver, but the Amplifier's output will be less. If you use an exciter that delivers more than 100 watts, carefully adjust the driving power to avoid "over-drive" and the creation of spurious signals which create needless interference to others. The use of the Heathkit Model 614 Monitor Scope is highly recommended for continuous output monitoring. The display on an oscilloscope is the best readily available way of determining the amplitude of the voice peaks which, if excessive, can cause "flat topping" and the radiation of distortion products.

**IMPORTANT:** In no case should the MIC/CW Level of your exciter be advanced beyond the point where the Amplifier REL. PWR. indication ceases to increase. If the level control is turned past this point, nonlinear operation may be produced.

### ALC (Automatic Level Control)

When the Amplifier is overdriven, the ALC circuitry creates a negative voltage which is fed back to the exciter to reduce its gain and help prevent "flat topping."

Protective circuitry of this nature is a valuable circuit element, but it is not a substitute for proper adjustment of the exciter drive.



## TUNE-UP

The current and voltage figures given in this section are approximations. Actual readings will vary at each installation with such factors as line voltage, exciter drive, and load impedance.

The following procedure for tuning the Amplifier should take only a few seconds after you go through it a few times. Note the LOAD control position so it can be preset the next time a particular band is used.

### CW AND RTTY PROCEDURE

Make sure the Amplifier has been installed as described and illustrated in the "Installation" section. **IMPORTANT:** Before you proceed make sure you have a dummy load (such as the Heathkit cantenna) or an appropriate antenna connected to the Amplifier output.

( ) Set the Amplifier controls as follows:

SWITCH OR CONTROL	POSITION	COMMENTS
TUNE	Desired band segment	
LOAD	1 (80 and 40 bands) 4 (20, and 15, bands)	After tune-up, note position so control can be preset in the future.
BAND	Desired band	
SENSITIVITY	12 o'clock	Keep needle on scale with SENSITIVITY control. After tune-up, adjust as desired.
METER	REL. PWR.	
POWER	OFF	
MODE	CW/TUNE	

$$\frac{2100}{1.57 \times .35}$$

$$\begin{array}{r} 2 \\ 55 \overline{) 2100} \\ \underline{110} \\ 100 \\ \underline{90} \\ 100 \\ \underline{90} \\ 100 \end{array}$$

55.

$$\begin{array}{r} R \ 2 \\ 1.57 \\ \cdot 35 \\ \hline 785 \\ 471 \\ \hline 54.95 \end{array}$$

$$\begin{array}{r} 41 \\ 55 \overline{) 210000} \\ \underline{165} \\ 450 \\ \underline{470} \end{array}$$



- ( ) Tune your exciter for full CW output at the desired frequency. The MULTI-METER on the Amplifier, when switched to indicate REL. PWR., will show the relative power output of the exciter and may be used even though the Amplifier is off.
- ( ) Reduce the exciter output to 0 by placing its controls in the receive mode; also turn its MIC/CW Level control fully counterclockwise.
- ( ) Turn the Amplifier on.
- ( ) Place the exciter in the tune mode. The amplifier plate meter should read approximately .12 ampere resting plate current. Then advance the Level control until the PLATE METER shows .3 ampere.
- ( ) Peak (adjust) the amplifier TUNE and LOAD controls for maximum REL. PWR. meter indication.
- ( ) Advance the drive to .4 ampere plate current and repeak the TUNE and LOAD controls. The Meter readings should then be approximately:
  - Plate amperes = .35
  - High voltage = 2100
  - Grid mA = 110
- ( ) Alternately adjust the TUNE, LOAD, and exciter drive controls for the desired input. Refer to Pictorial 6-4; the meter readings at one full kilowatt input will be as shown.
- ( ) Advance the SENSITIVITY control for the desired REL. PWR. meter reading.
- ( ) Turn the exciter Mode switch to Standby or the desired transmission mode.

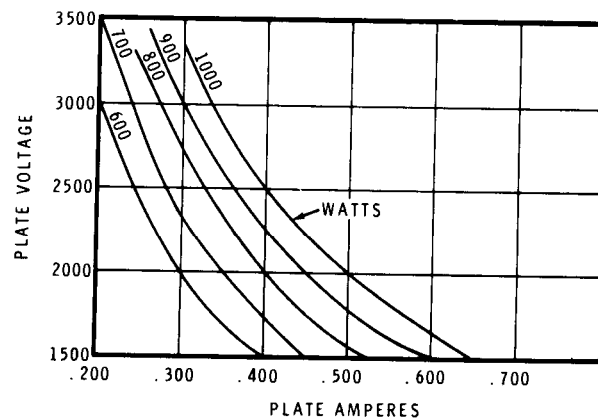

PICTORIAL 6-4

The Linear Amplifier is now loaded for operation on CW or RTTY. If you are using an oscilloscope for monitor, you should obtain a display similar to that shown in Pictorial 6-5. If you have a Heathkit Model 614 Monitor Scope, you may find that its optional trapezoid display pattern is more easily interpreted for voice patterns.

**CAUTION:** As you transmit, DO NOT switch between CW/TUNE and SSB modes.

### SSB PROCEDURE

- ( ) Tune up the exciter and Amplifier as for CW operation. NOTE: In the absence of the recommended oscilloscope monitor, either the PLATEMETER or the REL. PWR. indication can be used to monitor SSB transmission. The PLATEMETER indications are easier to follow.

### Low Power SSB

- ( ) For 1000 watts P.E.P. operation, switch the exciter **only** to the SSB mode. Leave the amplifier MODE switch at CW/TUNE.
- ( ) Adjust the exciter drive control so the PLATE METER will indicate between .12 and .2 ampere with average speech. Hard voice peaks should not exceed .250 ampere.

### High Power SSB

- ( ) For 2000 watts P.E.P. operation, switch **both** the exciter and the amplifier MODE switch to SSB.
- ( ) Advance the exciter drive level until the PLATE METER reads from .2 to .3 ampere with average speech and no higher than .33 ampere on hard voice peaks. A higher drive level will cause "flat topping."

An example of a proper SSB oscilloscope pattern is shown in Pictorial 6-6. Note that there are sharp, distinct peaks. The number of patterns or "christmas trees" will depend upon the operator's voice characteristics and the scope sweep speed. Set the scope for approximately 30 Hz sweep.

Note that the meter reading on voice peaks will not be high, due to meter inertia and voice characteristics; however, the height of the oscilloscope pattern is greater than that shown in Pictorial 6-5.

Pictorial 6-7 shows the same voice pattern but with extreme "flat topping." The oscilloscope shows that no more useful power is being developed. When the drive level is too high the meter reads higher, but only distortion is developed.

## PERIODIC MAINTENANCE

Remove the top cover of the Amplifier and remove the dust at least once a year. Use the blower connection on a vacuum cleaner or a soft bristle brush. While the top cover is removed, add **one** drop of light machine oil to each fan bearing.

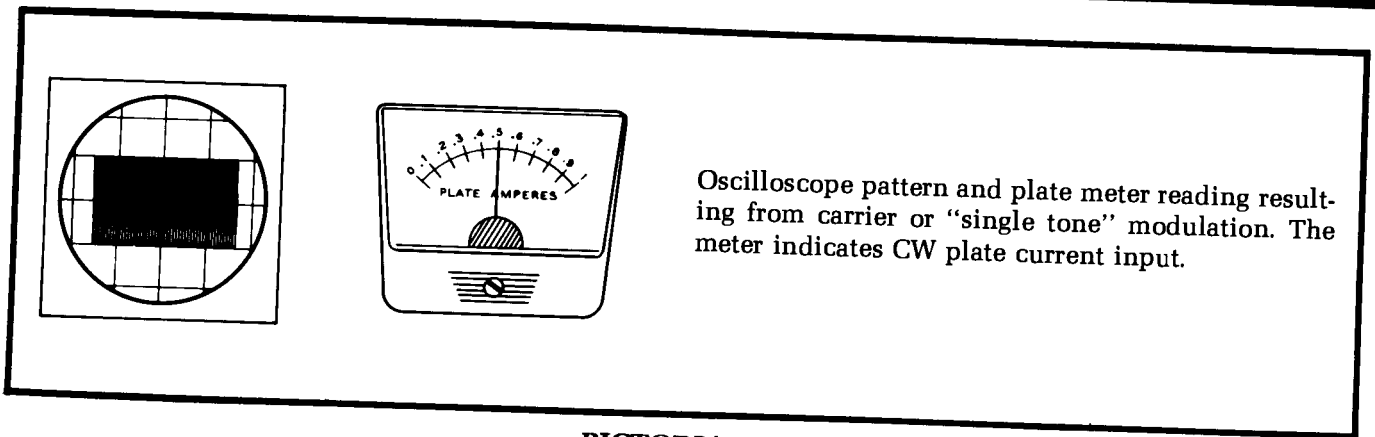

PICTORIAL 6-5

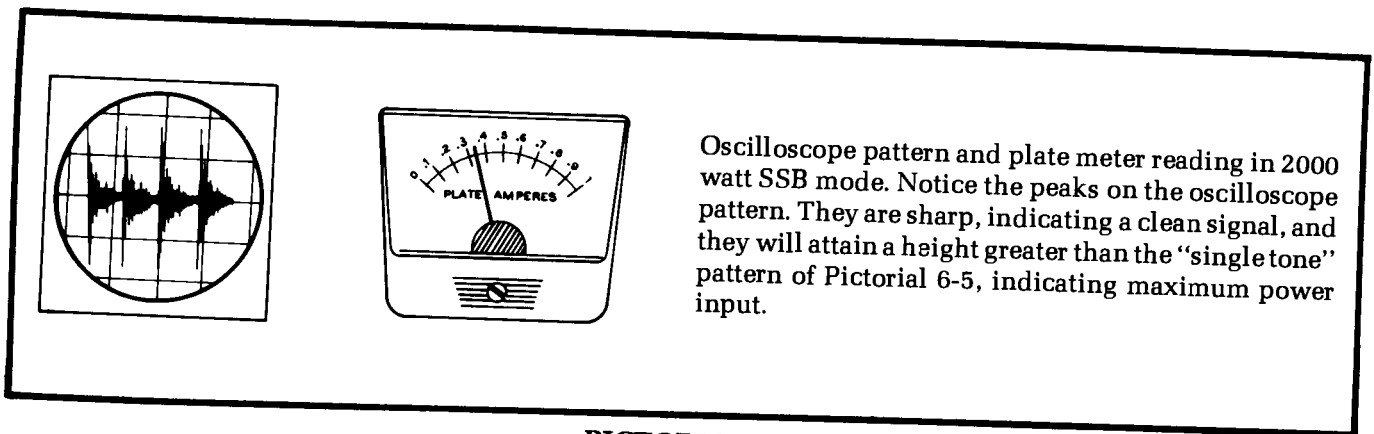

PICTORIAL 6-6

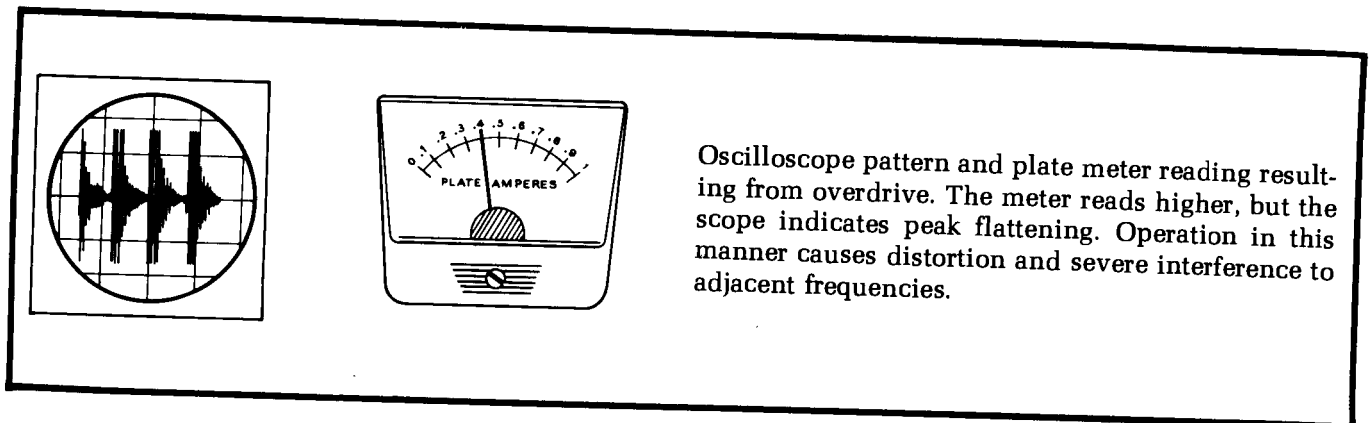

PICTORIAL 6-7

## IN CASE OF DIFFICULTY

NOTE: When you operate the Amplifier outside the specified power or frequency range (or both), components may be damaged. Such damage is not covered by the Heath warranty.

1. Recheck the wiring. Trace each lead in colored pencil on the Pictorial as it is checked. It is frequently helpful to have a friend check your work. Someone who is not familiar with the unit may notice something that you have consistently overlooked.
2. The majority of the kits that are returned for repair, do not function properly due to poor connections and soldering. Therefore, you can often eliminate many troubles by carefully reheating all connections to make sure that they are properly soldered.
3. Make sure that the tubes light up properly. If they do not, remove the tubes from their sockets and check for continuity between pins 1 and 5 with an ohmmeter. An infinite resistance will indicate a faulty tube filament.
4. Check the values of the parts. Be sure that the proper part has been wired into the circuit as shown in the Pictorial Diagrams and as called out in the wiring instructions.
5. Check for bits of solder, wire ends, or other foreign matter which may be lodged in the wiring.
6. A review of the Circuit Description will prove helpful in indicating where to look for trouble.

NOTE: Refer to the "Circuit Board X-Ray View" (Page 92) and the "Chassis Photographs" for the physical location of parts.

NOTE: In an extreme case where you are unable to resolve a difficulty, refer to the "Customer Service" information inside the rear cover of the Manual. Your Warranty is located inside the front cover.

### SPECIAL SHIPPING INSTRUCTIONS

If you return this Amplifier to the Heath Company for servicing, do not ship the Amplifier with the high-voltage transformer installed. To remove the transformer, use the following procedure:

1. Remove the cabinet from the Amplifier. Be sure you disconnect the line cord.
2. Remove the top cover from the Amplifier.
3. Remove the right side panel from the chassis.
4. Carefully unsolder the red wire from hole D on the circuit board.
5. Carefully unsolder the red-yellow wire from the positive lug of capacitor C14.
6. Unplug the transformer from socket Y.
7. Remove the four mounting screws and remove the transformer.
8. Replace the right side panel, the top cover, and cabinet. Be sure to use plenty of packing material.

NOTE: It is not necessary to return the transformer with the Amplifier when you return it for service.



## TROUBLESHOOTING CHART

DIFFICULTY	POSSIBLE CAUSE
1. No AC power	A. Circuit breakers open. B. Jumpers missing on terminal strip AE. C. Terminal strip AE wired wrong. D. High-voltage transformer not plugged in.
2. Meter inoperative in one position: A. GRID. B. REL. PWR.  C. HV.	A. Resistor R1, R3. B. D17, R25, R24, C54, R26. C. R6, R7, R8, R9. D. Meter switch.
3. Meter circuits inoperative	A. Meter jumper wire not removed. B. R2, C3, C8. C. Meter switch.
4. Idle current over .15A in CW/TUNE position.	A. ZD1.
5. No idle current	A. Relay. B. ZD1. C. V1-V2.
6. No high voltage	A. D1-D4. B. C10-C17. C. R12-R19. D. T1.  E. R1 or R3. F. C29. G. Top cover off (interlock).
7. Relay K1 will not activate	A. D16. B. C4. C. Anti-Relay jack.  D. T2. E. RL-1.
8. Final tune has no effect.	A. Band switch wafer #2 160 degrees out of position. B. L7 installed wrong. C. Improper load on the Linear Amplifier. D. V1, V2.
9. No RF output	A. Relay wired wrong. B. L7 installed wrong. C. Coax shorted. D. C29.
10. ALC inoperative	A. Wiring error or component failure on terminal strip BE. B. ALC jack.
11. Amplifier hard to drive.	A. Coaxial leads to the input band switch reversed.
12. Plate current does not increase with added drive power.	A. Driver and Amplifier set on different bands.
13. Filament transformer T2 burns out on 220 volts.	A. Open primary on Transformer T1.



## SPECIFICATIONS

Band Coverage .....	80, 40, 20, and 15 meter amateur bands.
Driving Power Required .....	100 watts, maximum.
Maximum Power Input .....	SSB: 2000 watts P.E.P. CW: 1000 watts. RTTY: 1000 watts.
Duty Cycle .....	SSB: Continuous voice modulation. CW: Continuous (maximum key-down 10 minutes.) RTTY: 50% (maximum transmit time 10 minutes).
Third Order Distortion .....	-30 dB or better.
Input Impedance .....	52 $\Omega$ unbalanced.
Output Impedance .....	50 $\Omega$ unbalanced; SWR 2:1 or less.
Front Panel .....	Tune. Load. Band switch. Sensitivity. Meter switch. Power. CW/Tune — SSB. Plate meter. Multi-meter (grid mA, Relative Power, and High Voltage).



---

Rear Panel .....	Line cord. Circuit breakers (two 10-ampere). Antenna Relay (phono). ALC (phono). RF Input (SO-239). Ground post. RF output (SO-239).
Tubes .....	Two 3-500Z.
Power Required .....	120 VAC, 50/60 Hz, at 20 amperes maximum. 240 VAC, 50/60 Hz, at 10 amperes maximum.
Cabinet Size .....	14-7/8" wide, 8-1/4" high, 14-1/2" deep.
Net Weight .....	50 lbs.

---

The Heath Company reserves the right to discontinue products and to change specifications at any time without incurring any obligation to incorporate new features in products previously sold.



## CIRCUIT DESCRIPTION

Refer to the Schematic (fold-in) to identify the circuit components while you read this section.

### POWER SUPPLY

The power supply uses high voltage transformer, T1, and a filament and bias transformer, T2. Each transformer has dual primary windings which are connected in parallel for 120 VAC operation, or in series for 240 VAC electric service. The transformers are protected by two 10-ampere circuit breakers, wired so they provide appropriate overload protection for either primary voltage.

The fan motor is connected across one of the primary windings on the high voltage transformer and always operates on 120 VAC.

The AC input line is by-passed for RF by capacitors C1 and C2.

#### HIGH VOLTAGE SUPPLY

The primary windings of the high voltage transformer, T1, are tapped, and the six leads are connected to the Mode and Power switches.

When the Mode switch is in the CW/Tune position, the entire portion of each primary winding is connected to the power line. When this switch is in the SSB position, only the tapped portion of each primary winding is connected to the power line.

When the tapped windings (fewer turns) are connected to the power source, a higher secondary-to-primary turns ratio is being used and a higher secondary voltage for SSB operation results.

The transformer secondary is connected in a full-wave, voltage-doubling circuit. The AC voltage is rectified by diodes, D1 through D14, and it is filtered by series-connected electrolytic capacitors C10 through C17. Resistors R12 through R19 parallel the filter capacitors and equalize the voltage drop across each capacitor in the series. They also act to discharge the filter capacitors after the power switch is turned off.

The red-yellow transformer lead is connected to the junction of capacitors C13 and C14. During the half-cycle when this lead is positive, capacitors C14 through C17 are charged. During the other half-cycle, the red lead is positive and capacitors C10 through C13 are charged. These two capacitor strings are in series across the load, and the voltages of each group add together.

Resistors R1 and R3 are discussed under "Metering Circuits."

Chokes RFC1 and RFC2 and bypass capacitors C6 and C7 are used to keep RF energy out of the power supply circuits.

The interlock grounds the output of the high voltage supply when the top cover of the Amplifier is removed. This feature protects the user against a shock from undischarged filter capacitors. The Amplifier must not be turned on while the top cover is removed as the high voltage supply is short-circuited under these circumstances.



## FILAMENT AND BIAS SUPPLY

Transformer T2 has two secondary windings. One winding furnishes 5 VAC at 30 amperes for the amplifier tube filaments. The #47 pilot lamps, PL1 and PL2, which are used for meter illumination, are also connected across the filament line.

Filament supply is fed to the two tubes through RFC3, a coil which is bifilar wound on a ferrite core. This coil forms a choke to raise the tube filaments above RF ground so the driving voltage will not be short-circuited.

The second winding on transformer T2 is used in a half-wave rectifier circuit for the bias supply voltage, to operate relay K1 and to furnish ALC threshold voltage. The AC voltage from this winding is rectified

by diode D16 and filtered by capacitor C4.

This DC voltage is connected to lugs 3 and 11 of relay K1. In the receive mode, this voltage is applied through lug 9 to the center-tap of the filament winding. This positive voltage increases the voltage difference between the tube grids (which are grounded for DC) and the tube filaments, which now carry the positive DC voltage in addition to the AC filament voltage. The tube grids are consequently biased beyond cutoff and no plate current flows.

In the transmit mode, the center-tap of the filament winding is connected to ground through lugs 9 and 6 of the relay, the 5.1 volt zener diode ZD1, and resistor R3. The plate current through the zener develops 5.1 VDC operating bias for the tubes and limits the idling plate current.

## RELAY

Relay K1 has three sets of single-pole, double-throw contacts. When the relay coil circuit is open the contacts are in the receive mode.

Approximately 120 VDC is connected to one side of the relay coil at lug 11. Lug 10 connects the other side of the relay coil to the Antenna Relay jack on the rear panel. This jack is usually connected to normally open relay contacts in the exciter (such as a VOX or PTT relay). When these relay contacts close, they must connect the amplifier relay coil circuit to ground. The amplifier relay will then close and its contacts will be in the transmit mode.

The function of amplifier relay contacts 3, 6, and 9 was discussed in the "Bias Supply" section.

Relay contact 7 is connected to the RF INPUT connector. In the receive mode the incoming signal is transferred directly to the RF Input through relay contacts 8, 2, 1, and 7. In the transmit mode, the RF Input voltage is connected through relay contacts 7 and 4 to lug 1 of Band-switch wafer 1F.

In the transmit mode, the RF Output is connected through relay contacts 5 and 8 to the pi network output circuit of the Amplifier.

## RF CIRCUITS

### INPUT CIRCUIT

An input impedance-matching pi network circuit for each band is connected by Band switch wafer A. After passing through the matching circuit, the RF driving power is coupled to the tube filaments by capacitor C32. Capacitor C21 equalizes any RF voltage difference between the filament leads.

### TUBES

The amplifier tubes are connected in parallel in a class B grounded grid circuit. RF driving power is applied to the filaments in the normal cathode-driven configuration. As mentioned in the "Power Supply" section, choke RFC3 holds the filaments above RF ground.

Pins 2, 3, and 4 of each tube are connected together internally. Each of the three grid pins is bypassed to ground. This combination of RF chokes and capacitors provides a predetermined level of negative feedback at the tube grids to further reduce intermodulation distortion.

PC-1 and PC-2 are parasitic chokes in each tube plate lead to suppress any VHF parasitic oscillations.

The positive side of the power supply is connected in parallel to the tubes through RFC1.

Cooling air is circulated around the tubes by the fan.

### OUTPUT CIRCUIT

The tuned output circuit of the Amplifier is a pi network composed of plate Tune capacitor C55, loading capacitors C56 and C57, and coils L4 and L5.

Band switch wafer 2 progressively shorts out the unused portions of coils L4 and L5. The coil turns in use are tuned to resonance by Tune capacitor C55. Load capacitor C57 is tuned to complete the impedance match between the tubes and the load connected to the RF Output. On the 80 meter band, fixed capacitor C56 is switched in parallel with Load capacitor C57 to provide the additional capacitance required on this band.

If a DC voltage is unintentionally applied to the plate output circuit, RFC6 will provide a DC path to ground, thus short-circuiting the high voltage supply and opening the circuit breakers.

## ALC CIRCUIT

Approximately 60 VDC ALC threshold voltage is available at the junction of resistors R4 and R5, which form a voltage divider across the bias supply winding of transformer T2. Capacitor C5 is an RF bypass, and resistor R11 is an isolation resistor.

Capacitor C47 couples some RF driving voltage to voltage divider resistors R21-R22. C48 and C49 are frequency compensating capacitors for resistors R21 and R22, respectively.

When the RF driving voltage at the junction of R21-R22 exceeds the ALC threshold voltage, diode D18 will rectify the negative half-cycles. Capacitors C51 and C53 act as filters and RF bypasses. R23 is an isolation resistor.

The negative voltage appearing at the ALC connector may be coupled back to the exciter to reduce its gain and help reduce "flat-topping" of voice peaks due to overdrive.



## METERING CIRCUITS

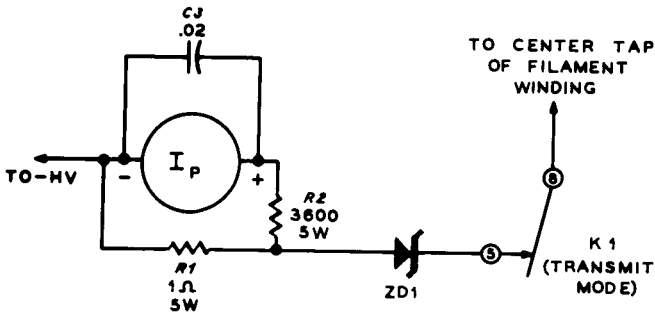

PICTORIAL 9-1

### PLATE METER (Pictorial 9-1)

The Plate meter reads the total plate current drawn by both tubes from 0 to 1 ampere. It is placed in series with a multiplier resistor, R2, and it measures the voltage drop across shunt resistor R1 through which the plate current passes.

### MULTI-METER

#### Grid Current (Pictorial 9-2)

To read grid current, the Multi-meter is switched in parallel with shunt resistor R3. The grid circuit return is to the center tap of the filament winding of transformer T2. Note that grid current only passes through resistor R3, as the return for the high voltage circuit is through resistors R1, R2, and the Plate meter.

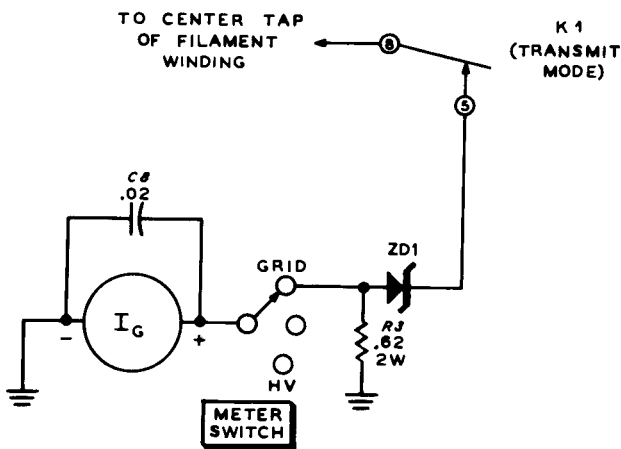

PICTORIAL 9-2

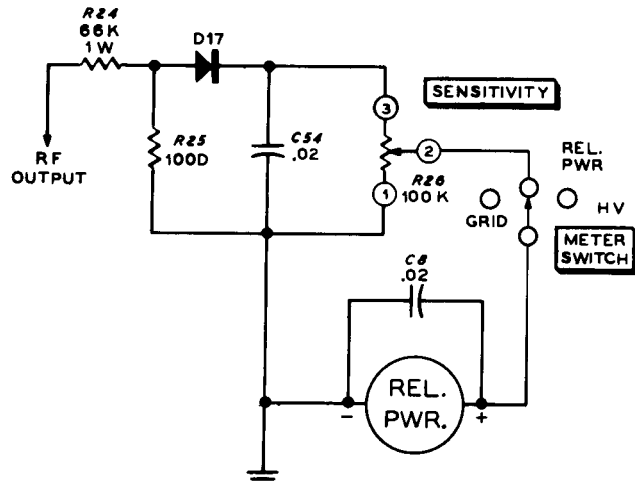

PICTORIAL 9-3

### Relative Power (Pictorial 9-3)

Voltage divider resistors R24 and R25 are connected across the RF Output. The voltage at the junction of these resistors is rectified by diode D17, filtered by capacitor C54, and applied through Sensitivity control R26 to the Multi-meter. The Sensitivity control adjusts the Multi-meter for the desired reading.

### High Voltage (Pictorial 9-4)

High voltage is measured by switching the Multi-meter to the junction of the multiplier resistors (R6, R7, and R8) and the shunt resistor R9. The meter scale is calibrated to indicate voltage, based upon the current flowing through the meter and resistor R9 in parallel, the combination being in series with the multiplier resistors R8, R7 and R6.

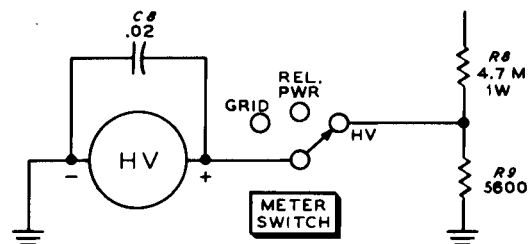

PICTORIAL 9-4

# CIRCUIT BOARD X-RAY VIEW

NOTE: To find the PART NUMBER of a component for the purpose of ordering a replacement part:

- A. Find the circuit component number (R1, C1, etc.) on the "X-Ray View" (or "Chassis Photographs").
- B. Locate this same number in the "Circuit Component Number" column of the "Parts List."
- C. Adjacent to the circuit component number, you will find the PART NUMBER and DESCRIPTION which must be supplied when you order a replacement part.

(NOTE: ZD1 IS WIRE-CONNECTED,  
CHASSIS-MOUNTED.)

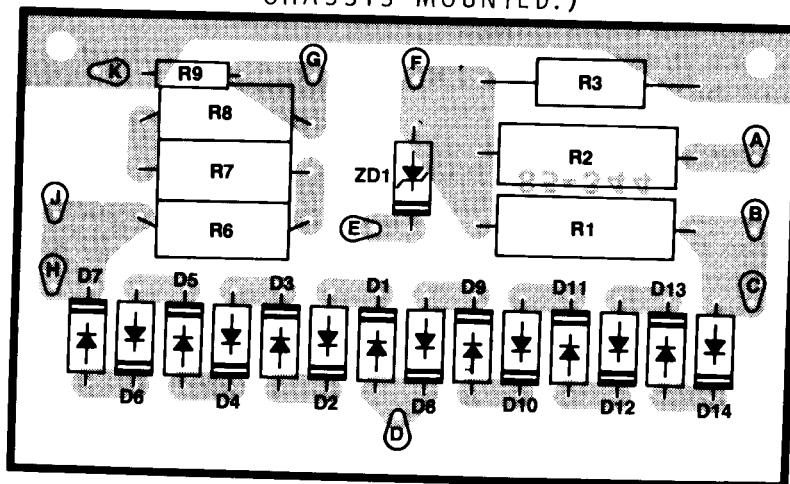

# CHASSIS PHOTOGRAPHS

NOTE: Dotted outlines indicate HAZARDOUS VOLTAGE areas.

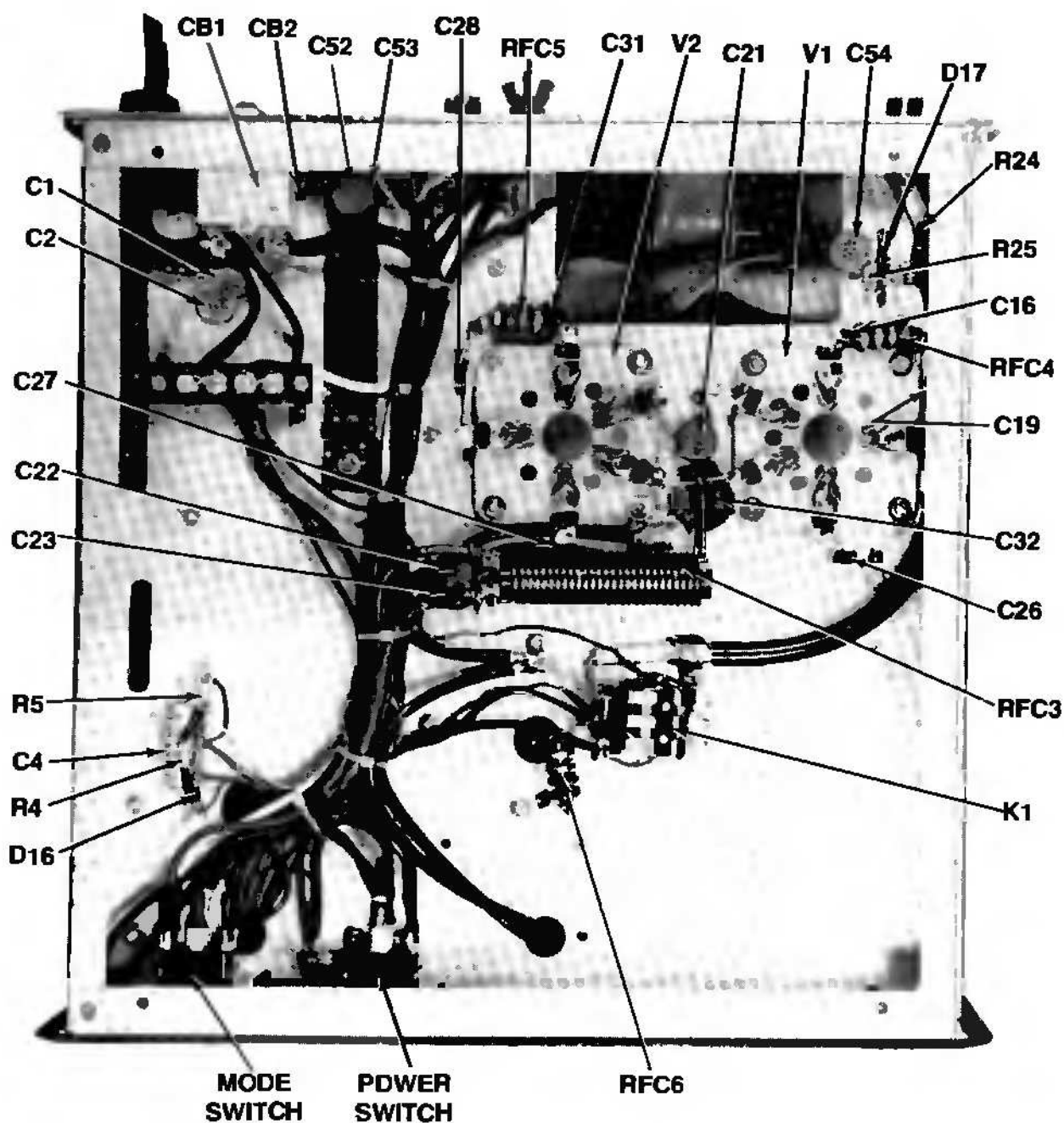

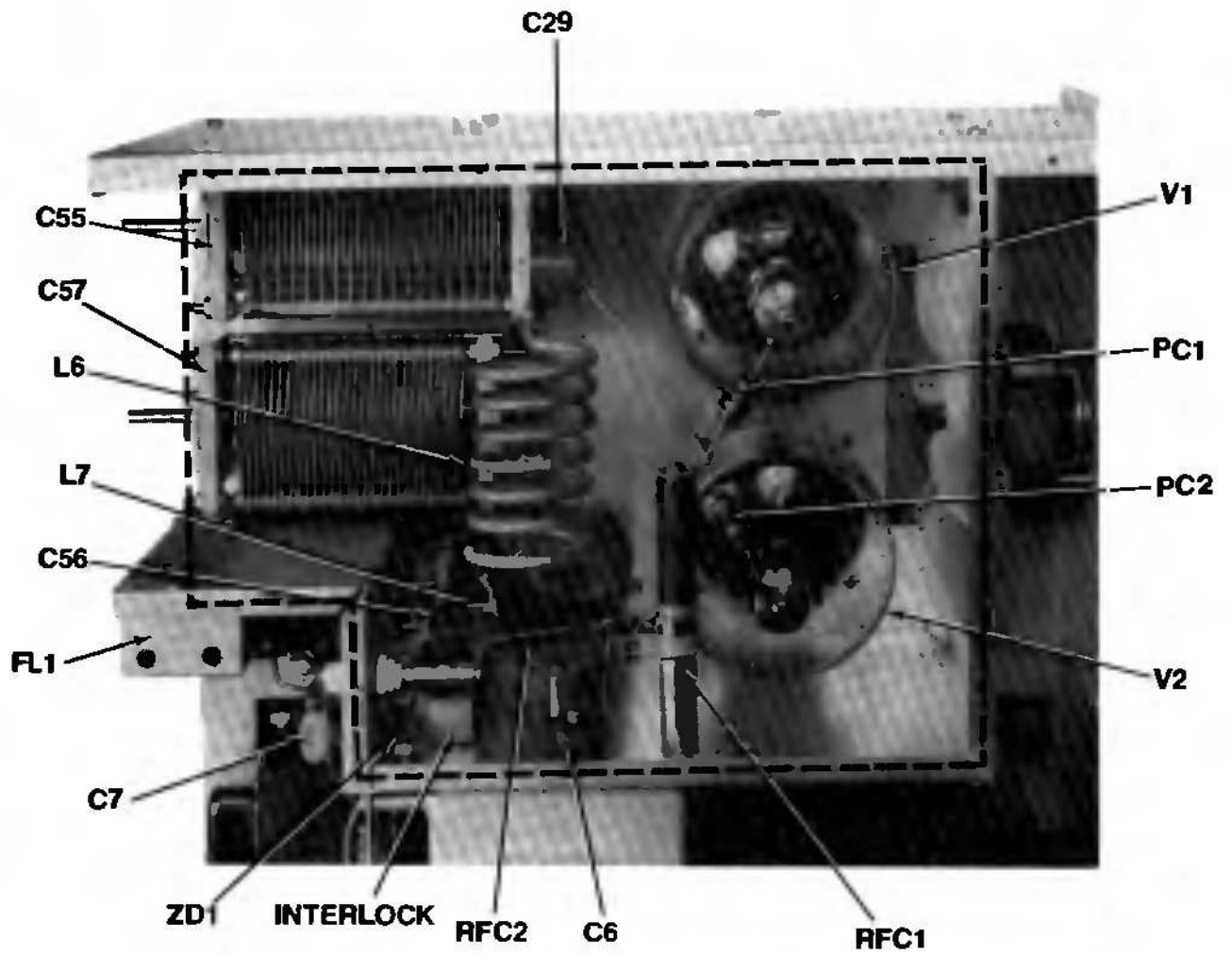

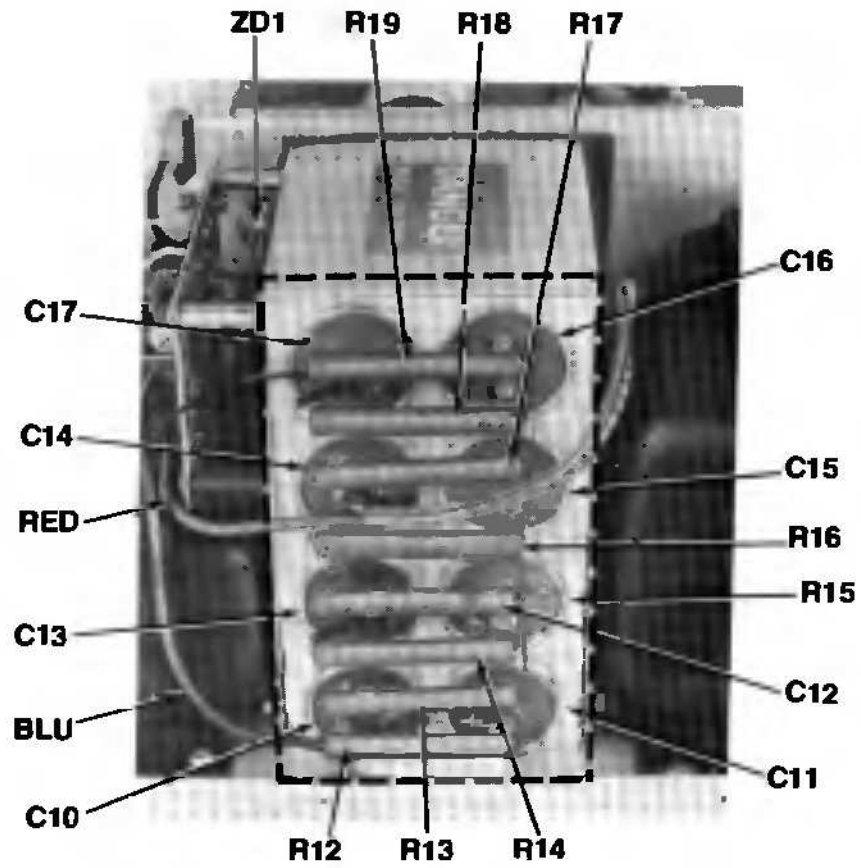
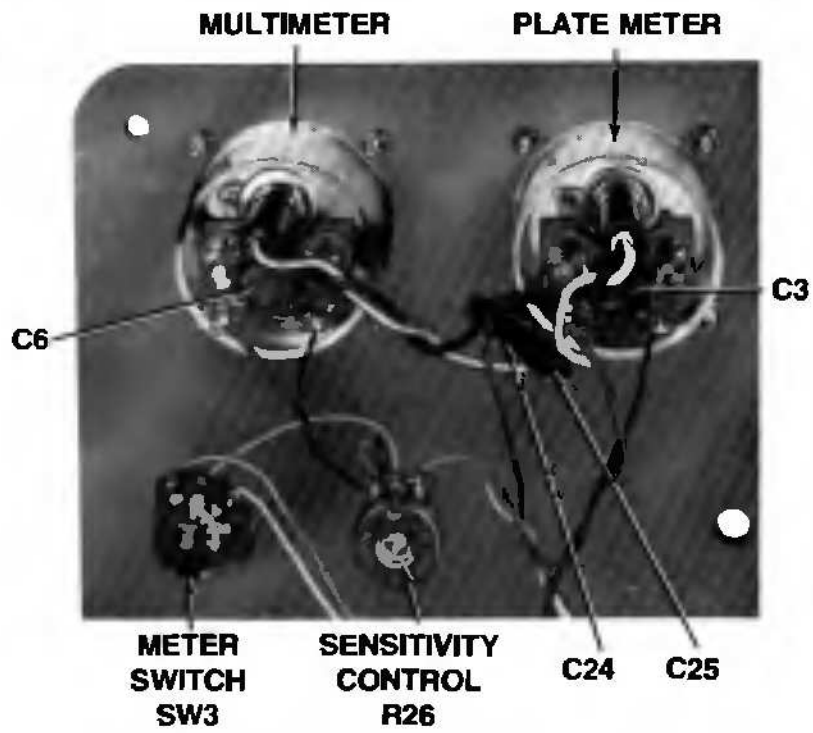



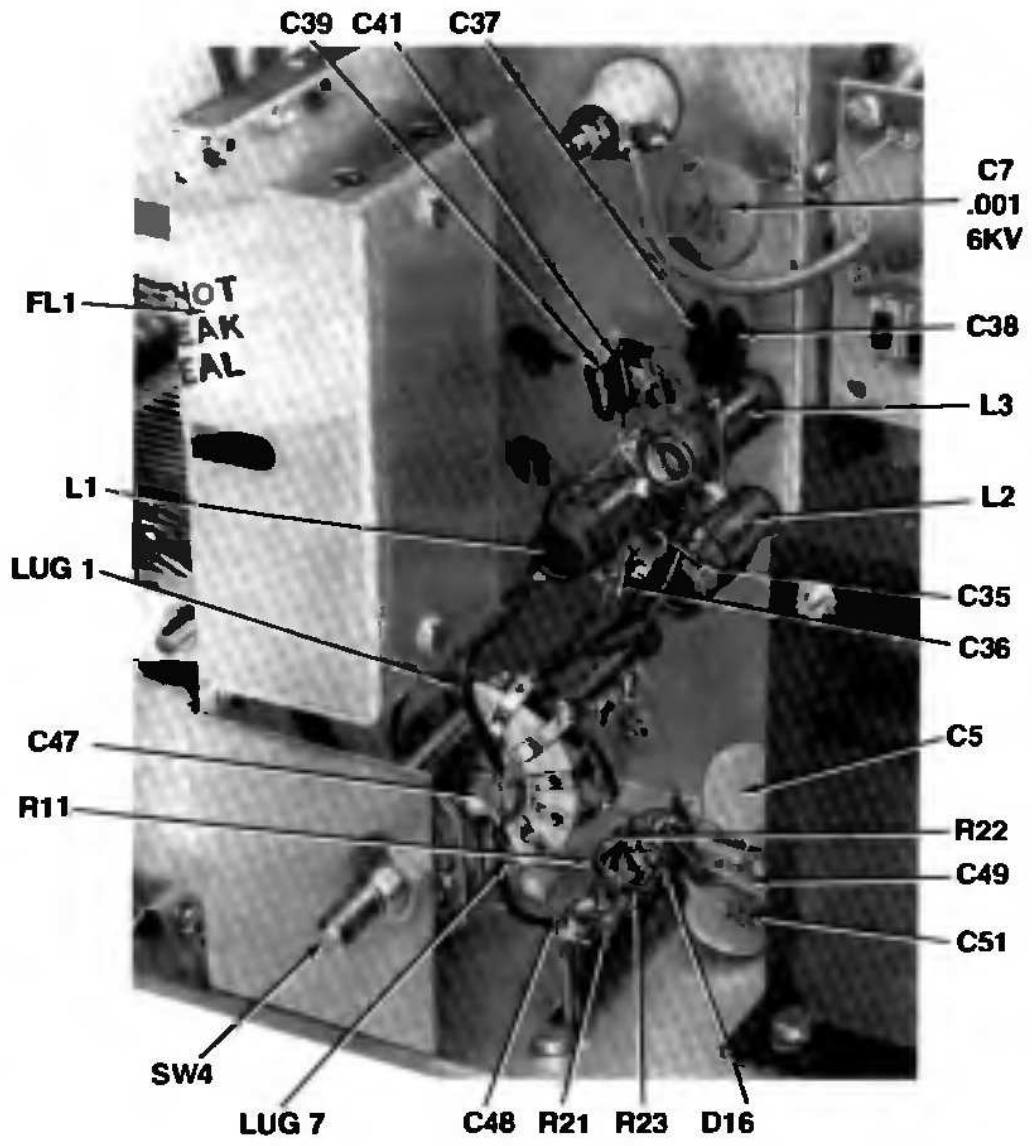

# SCHEMATIC OF HEATHKIT 2KW LINEAR AM MODEL SB-2

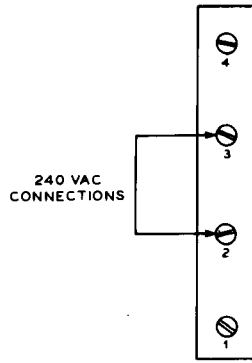

TERMINAL STRIP

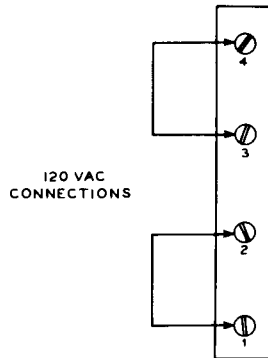

**NOTES:**

1. ALL RESISTORS ARE 1/2 WATT UNLESS OTHERWISE SPECIFIED. VALUES ARE IN OHMS (K=1000, M=1,000,000).
2. CAPACITOR VALUES LESS THAN 1 ARE IN MICROFARADS. VALUES ABOVE ARE IN pF UNLESS MARKED OTHERWISE.
3. THE BANDSWITCH IS IN THE 80 METER BAND POSITION. ARROWS INDICATE THE DIRECTION OF ROTATION.
4. THIS SYMBOL INDICATES A CONNECTION TO GROUND FOIL.
5. THIS SYMBOL INDICATES A CONNECTION TO THE PROPER HEATH PARTS.

Copyright © 1976  
Heath Company  
All Rights Reserved  
Printed in the United States of America

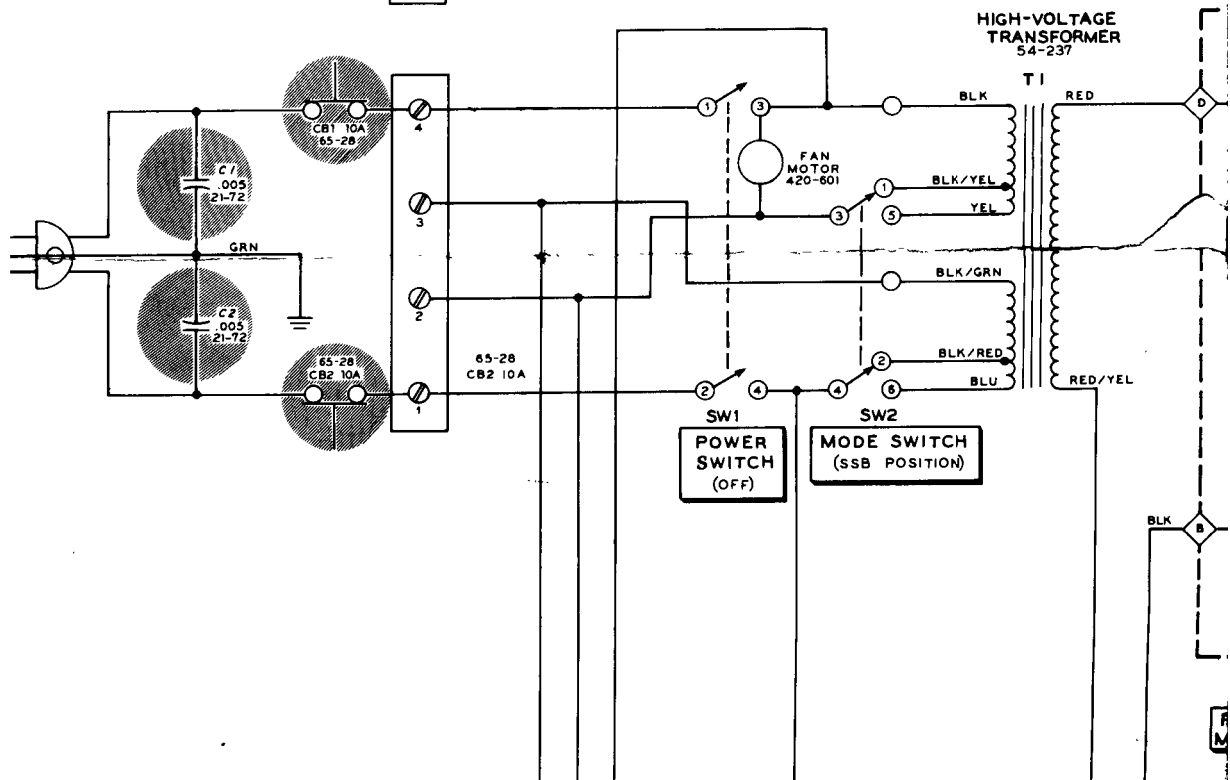

**SCHEMATIC OF THE  
HEATHKIT®  
100W LINEAR AMPLIFIER  
MODEL SB-221**

RESISTORS ARE 1/2 WATT UNLESS OTHERWISE INDICATED.

RESISTOR VALUES: K=1000, M=1,000,000.

RESISTOR VALUES LESS THAN 1 ARE IN  $\mu\text{F}$ . VALUES OF 1 AND ABOVE ARE IN OHMS UNLESS MARKED OTHERWISE.

RESISTOR VALUES IN THE 80 METER POSITION. ARROWS INDICATE DIRECTION OF ROTATION FOR THE VIEW SHOWN.

RESISTOR VALUES INDICATES A CONNECTION TO CIRCUIT BOARD

RESISTOR VALUES INDICATES A CONNECTION TO THE CIRCUIT BOARD.

RESISTOR VALUES ARE CRITICAL FOR CONTINUED SAFETY. REPLACE ONLY WITH PARTS OF THE SAME RATING OR WITH EQUIVALENT PARTS.

Part of 595-2201-04

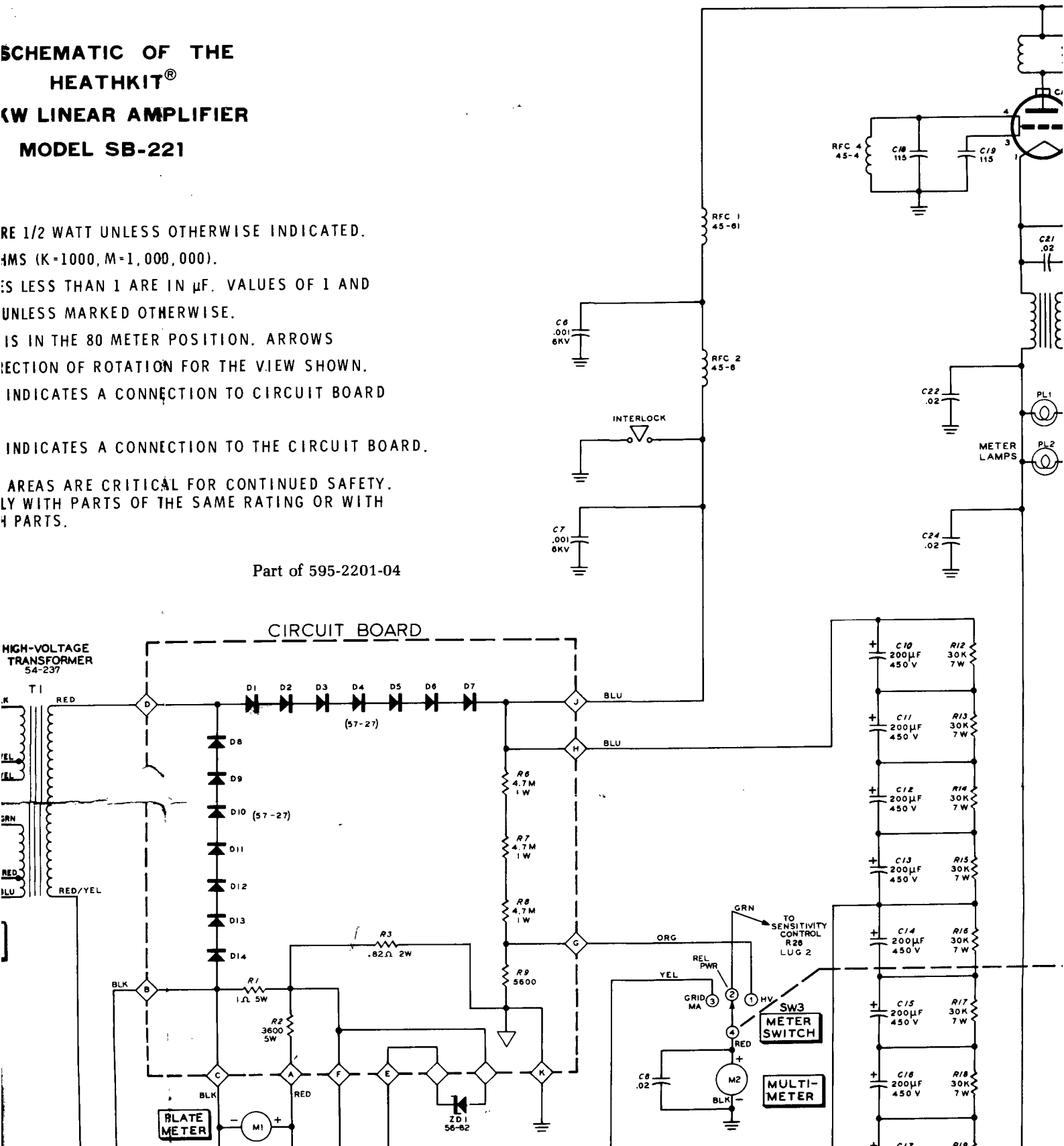

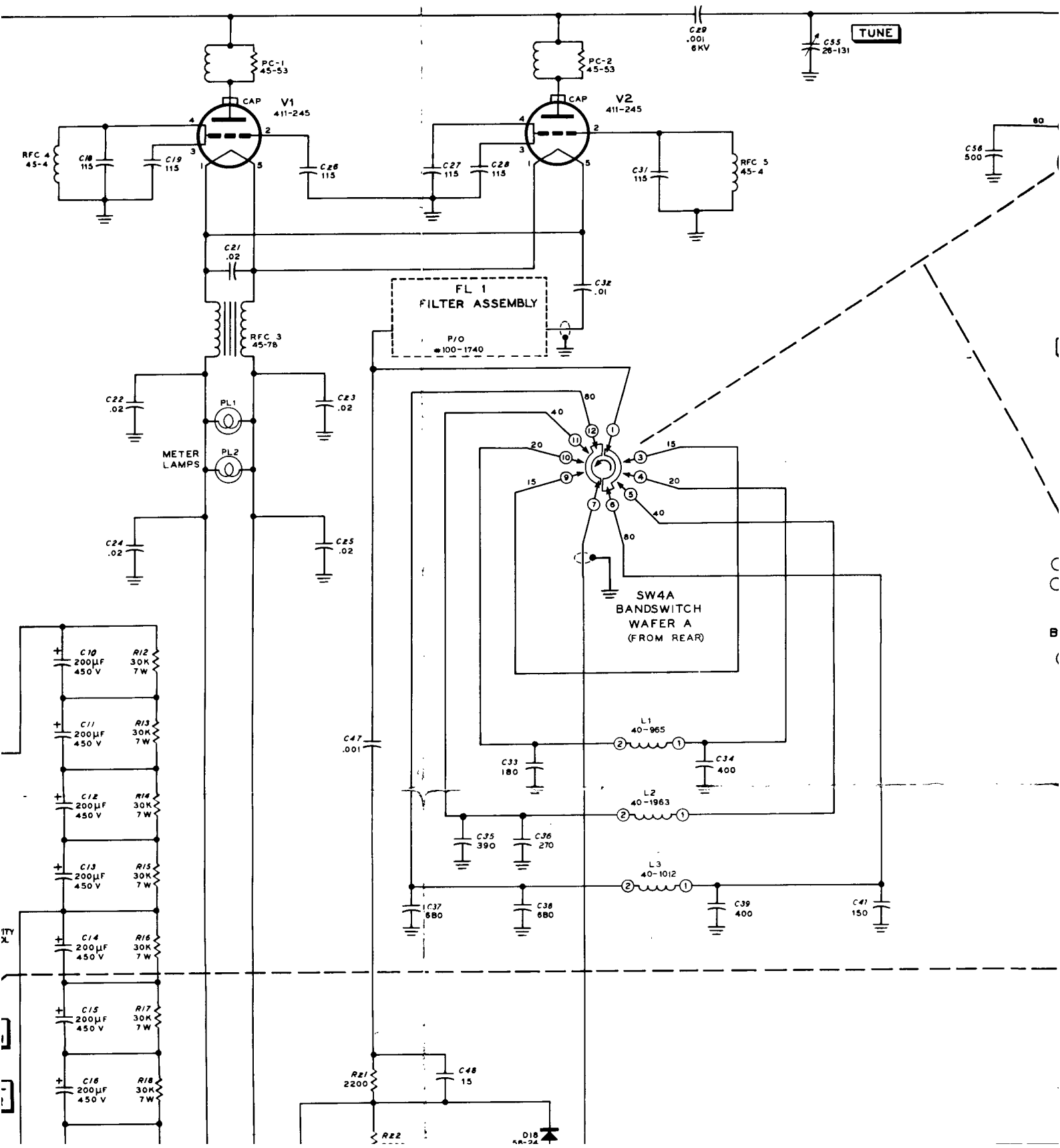

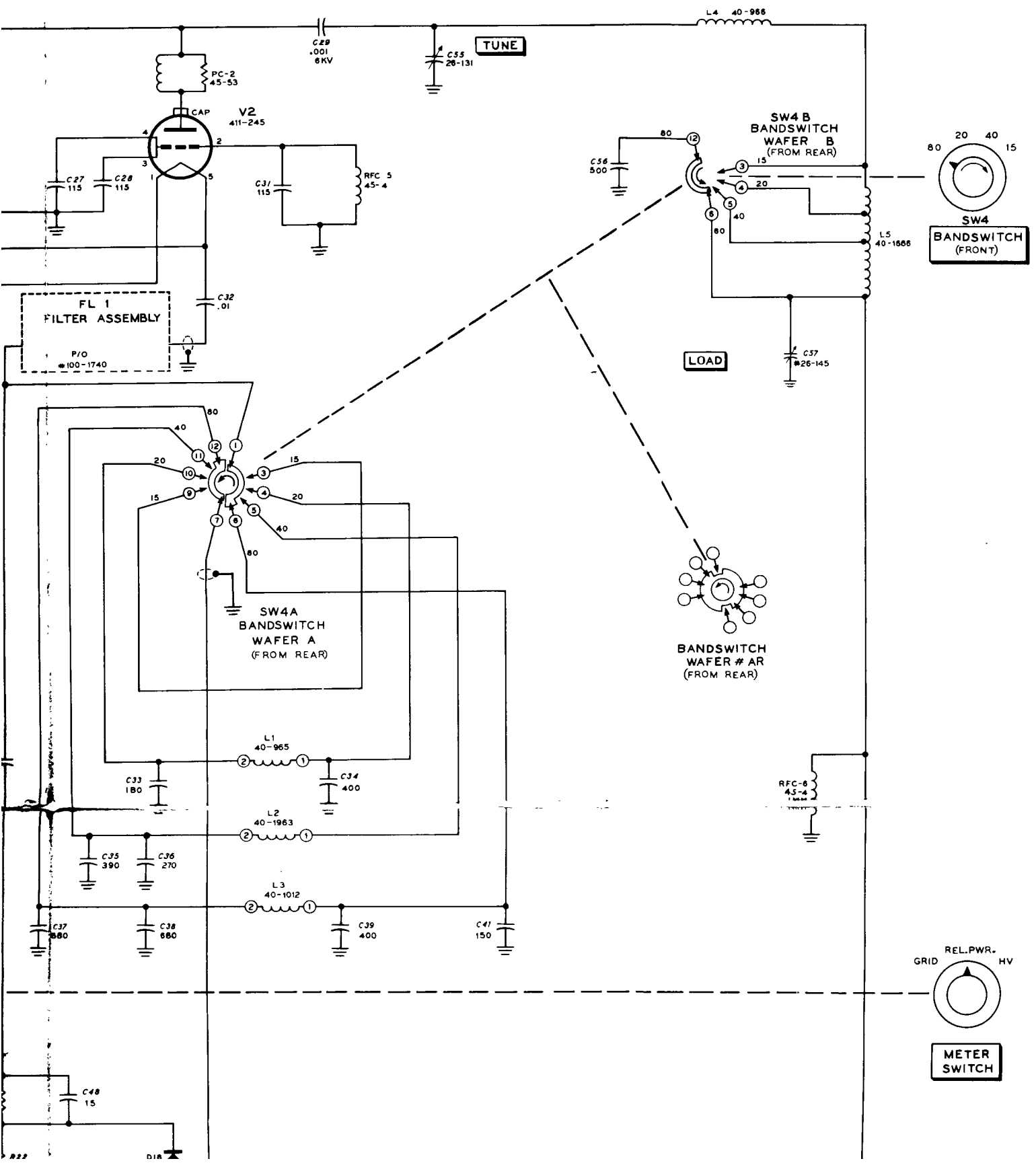

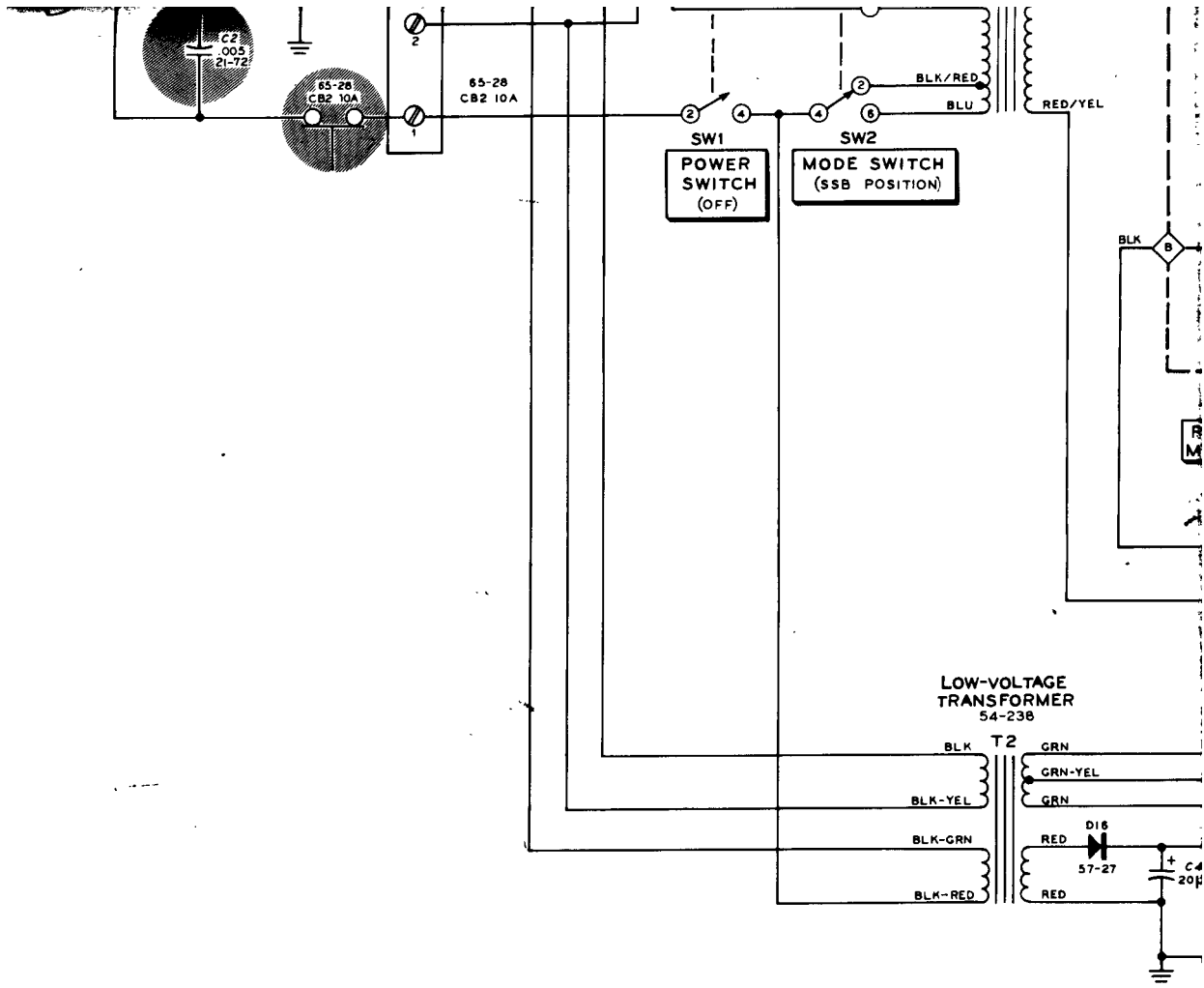

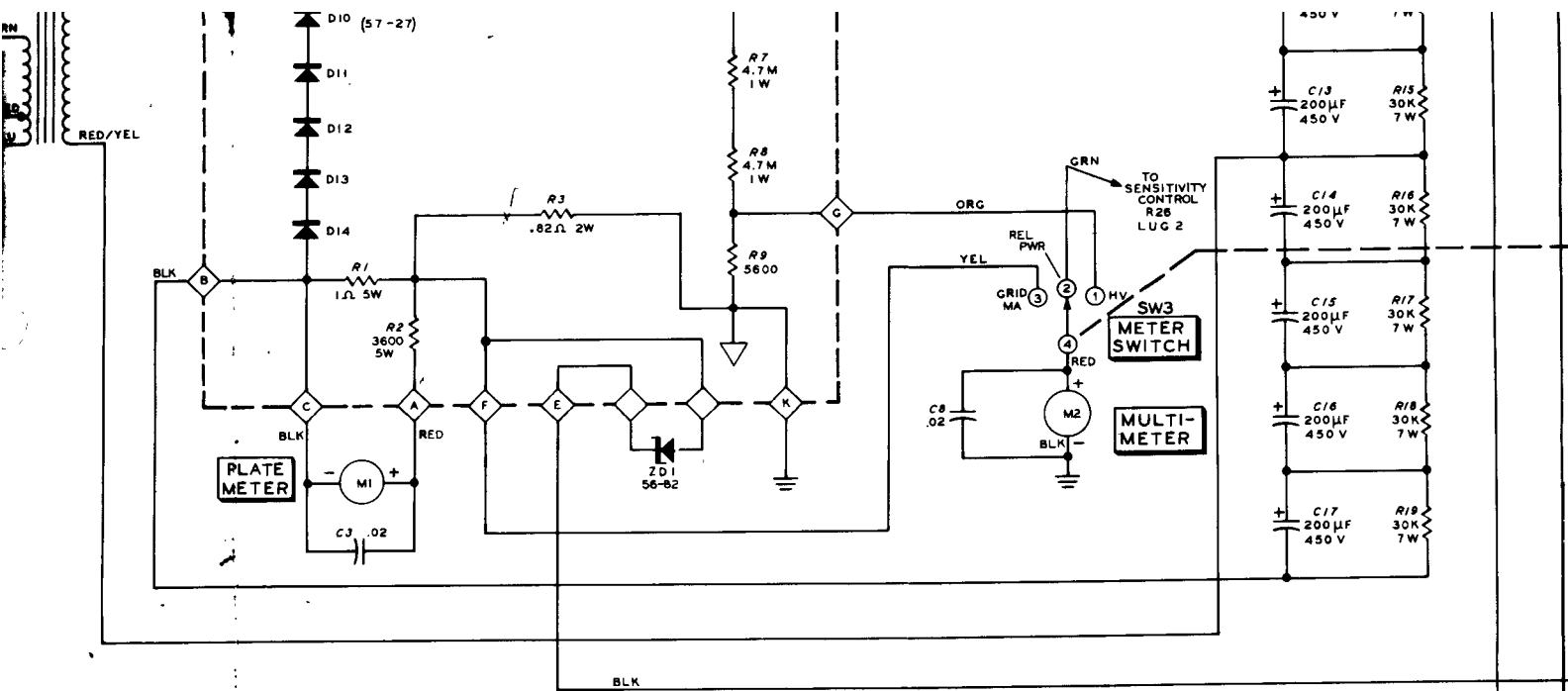

5W-VOLTAGE TRANSFORMER 54-238

