

Total solder points: 53

Difficulty level: *beginner* 1 2 3 4 5 *advanced*

OSCILLATOR



K1771

Great for baby monitoring, family
broadcasts, security, ...

Features

- ☑ Use it as a test oscillator for FM tuners
- ☑ For family broadcasts
- ☑ As part of a wireless microphone
- ☑ For security applications
- ☑ Nice gadget
- ☑ Your own unique application

*The use of this device as a transmitter might be illegal in your area. Please check with the local authorities. Eavesdropping into private conversations might be considered a crime in your area.

Specifications :

- High-quality varicap modulation
- Ultra stable FET oscillator
- Frequency range from 100 to 108 MHz
- FET input amplifier with high sensitivity (10mV max.)
- Easy microphone hook-up
- No coils to wind
- Reception with any FM radio*
- Miniature size, yet very sensitive
- Power supply : 9-12VDC (use battery for best results)
- Dimensions : 45 x 70 mm (1.8" x 2.7")

1. Assembly (Skipping this can lead to troubles !)

Ok, so we have your attention. These hints will help you to make this project successful. Read them carefully.

1.1 Make sure you have the right tools:

- A good quality soldering iron (25-40W) with a small tip.
- Wipe it often on a wet sponge or cloth, to keep it clean; then apply solder to the tip, to give it a wet look. This is called 'thinning' and will protect the tip, and enables you to make good connections. When solder rolls off the tip, it needs cleaning.
- Thin raisin-core solder. Do not use any flux or grease.
- A diagonal cutter to trim excess wires. To avoid injury when cutting excess leads, hold the lead so they cannot fly towards the eyes.
- Needle nose pliers, for bending leads, or to hold components in place.
- Small blade and Phillips screwdrivers. A basic range is fine.

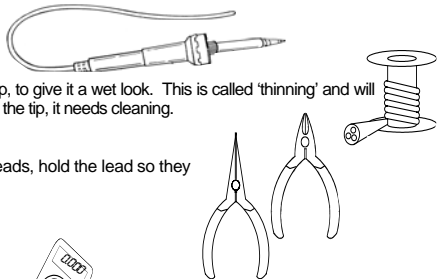

For some projects, a basic multi-meter is required, or might be handy



1.2 Assembly Hints :

- ⇒ Make sure the skill level matches your experience, to avoid disappointments.
 - ⇒ Follow the instructions carefully. Read and understand the entire step before you perform each operation.
 - ⇒ Perform the assembly in the correct order as stated in this manual
 - ⇒ Position all parts on the PCB (Printed Circuit Board) as shown on the drawings.
 - ⇒ Values on the circuit diagram are subject to changes.
 - ⇒ Values in this assembly guide are correct*
 - ⇒ Use the check-boxes to mark your progress.
 - ⇒ Please read the included information on safety and customer service
- * Typographical inaccuracies excluded. Always look for possible last minute manual updates, indicated as 'NOTE' on a separate leaflet.

1.3 Soldering Hints :

1- Mount the component against the PCB surface and carefully solder the leads

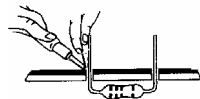

2- Make sure the solder joints are cone-shaped and shiny

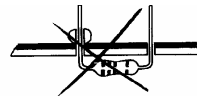
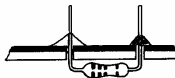

3- Trim excess leads as close as possible to the solder joint



AXIAL COMPONENTS ARE TAPED IN THE CORRECT MOUNTING SEQUENCE !

REMOVE THEM FROM THE TAPE ONE AT A TIME !

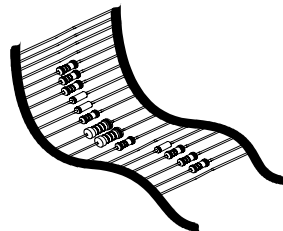

 You will find the colour code for the resistances and the LEDs in the HALG (general manual) and on our website: <http://www.velleman.be/common/service.aspx>

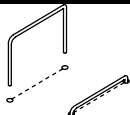
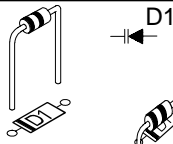
1. Jumper wire**2. Varicap diode. Watch the polarity !**

- D1 : BB909A or equivalent

3. Diode. Watch the polarity !

- D2 : 1N4148

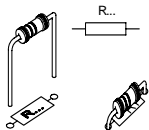
4. Resistors

- R1 : 100K (1 - 0 - 4 - B)
 R2 : 220K (2 - 2 - 4 - B)
 R3 : 22E (2 - 2 - 0 - B)
 R5 : 1K (1 - 0 - 2 - B)
 R6 : 56K (5 - 6 - 3 - B)
 R7 : 1M (1 - 0 - 5 - B)
 R8 : 1K2 (1 - 2 - 2 - B)

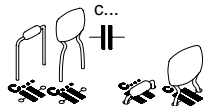
5. Capacitors

- C1 : 5pF (4p7)
 C2 : 6pF (5p6)

- C3 : 15pF (15)
 C5 : 15pF (15)
 C6 : 1nF (102)
 C9 : 100pF (101)
 C10 : 1nF (102)

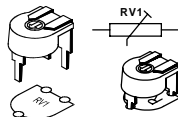
6. Trim potentiometer

- R4 : 1K

7. Electrolytic Capacitors. Watch the polarity !

- C7 : 100μF
 C8 : 4,7μF

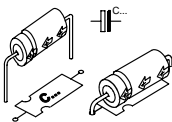

8. Trim capacitor

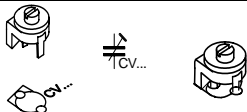

□ C4 : 22pF

9. Transistors

- T1 : BF245A
- T2 : 2N3819
- T3 : BC557B

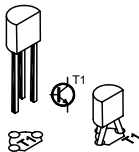

10. Connection example

Connecting a microphone

Adjust modulation with R4 until you hear that the signal received on your radio (tuned between 100MHz and 108MHz) is loud, clear and without distortion.

Dynamic microphone

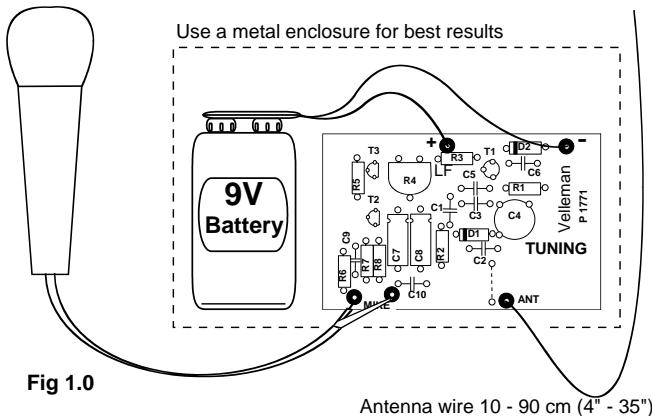

Connecting an electret microphone

If you want to connect an electret microphone to the FM oscillator, connect the + of the power supply with the + connection of the electret microphone via an additional 27K Ω resistor.

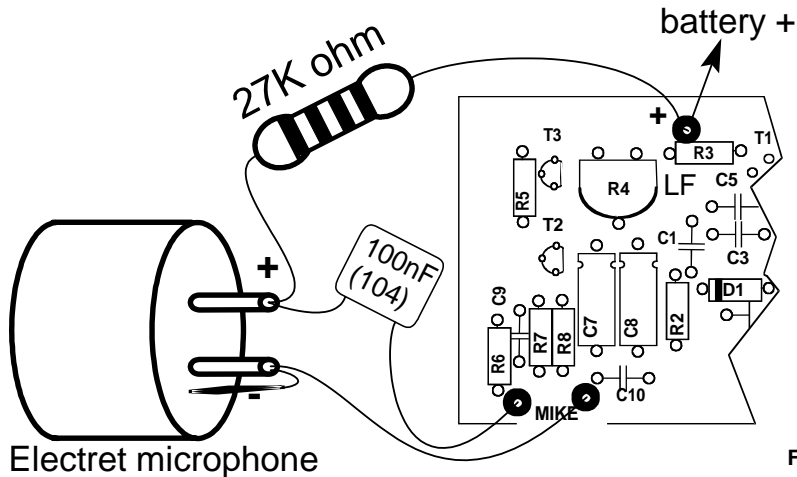

Fig 2.0

Connecting of an input level signal

If you want to use a signal from another audio source, you will have to attenuate the signal with a trim pot twice the output impedance value of your source. Trim R4 for the highest modulation and adjust your attenuator trim pot until you get a loud and clear signal as described in the procedure for microphone hook-up.

signal from CD player, radio, mixer, ...

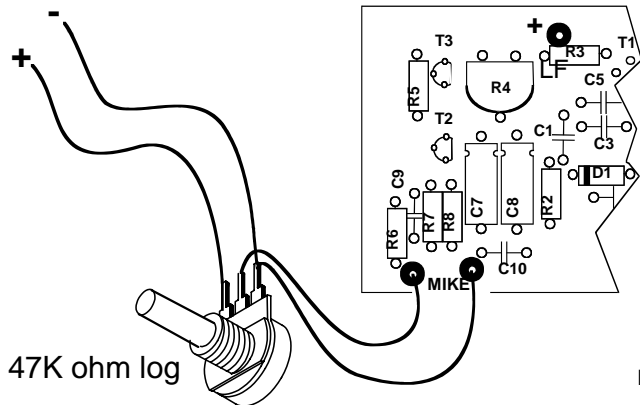
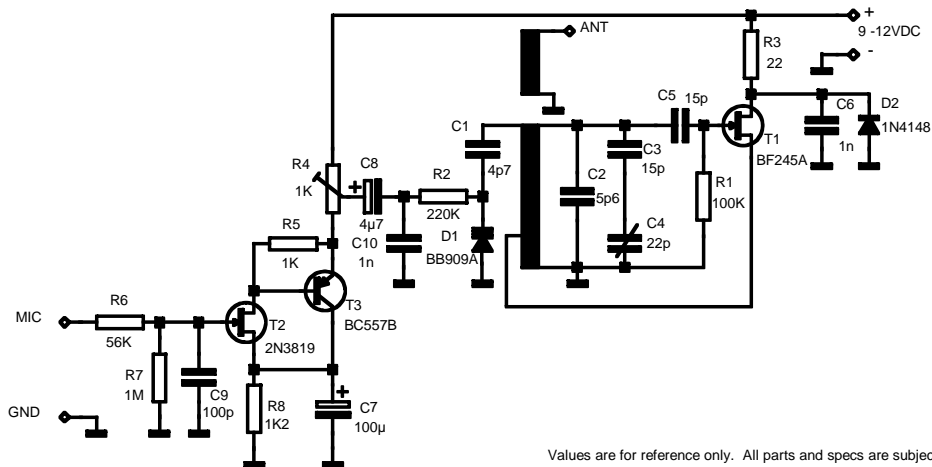

Fig 3.0

11. DIAGRAM



Values are for reference only. All parts and specs are subject to changes

12. PCB

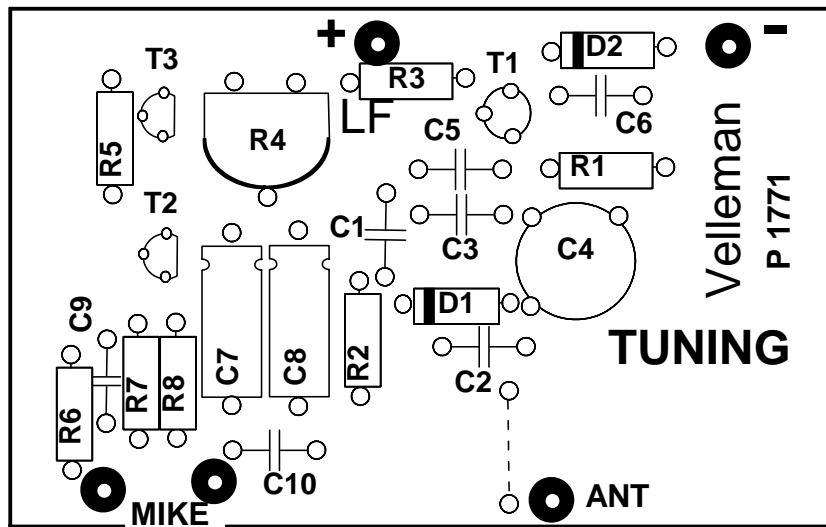



Modifications and typographical errors reserved
© Velleman Components nv.
H1771IP - 2004 - ED1

