

ELENOS Via G. Amendola 9 44028 Poggio Renatico (FE) Italy
Tel +39 0532 829965 Fax +39 0532 829177
Website WWW.ELENOS.COM

Title: **LINEAR POWER SUPPLY**

Board Code:	Model: E2500	Rev 0
Proj. Engr. : A.Tomassini	Approved : A.Giovannelli	
Date: Wednesday, November 15, 2000	Sheet 1 of 1	

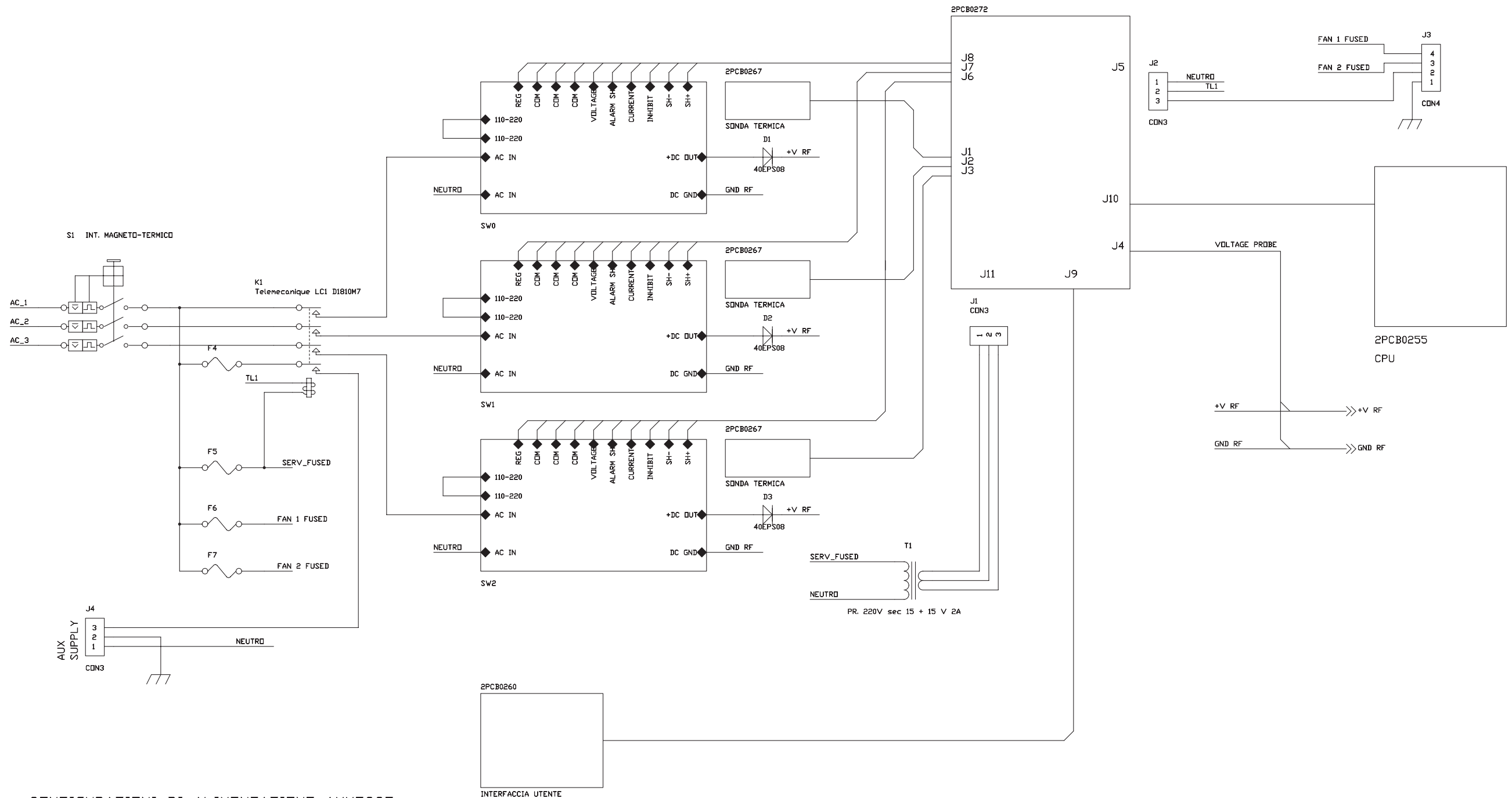

CONFIGURAZIONI DI ALIMENTAZIONE AMMESSE

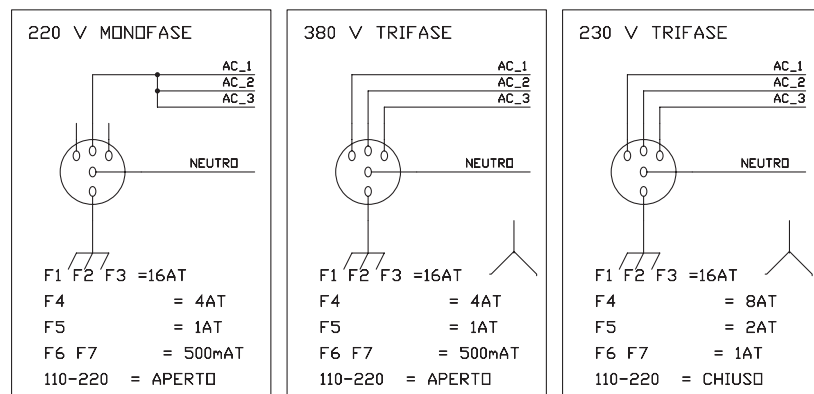

ELENOS		Via G. Amendola 9 44028 Poggio Renatico (FE) Italy Tel +39 0532 829965 Fax +39 0532 829177 Website WWW.ELENOS.COM	
Title: SWITCHING POWER SUPPLY			
Board Code:	Model: E2500	Rev	0
Proj. Engr. : A.Tomassini	Approved : A.Giovannelli		
Date: Wednesday, November 15, 2000	Sheet	1	of 1

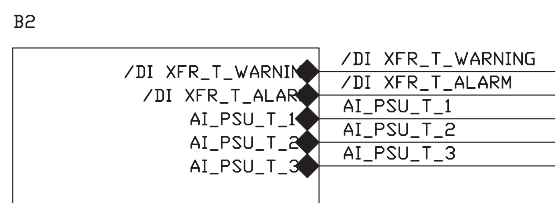
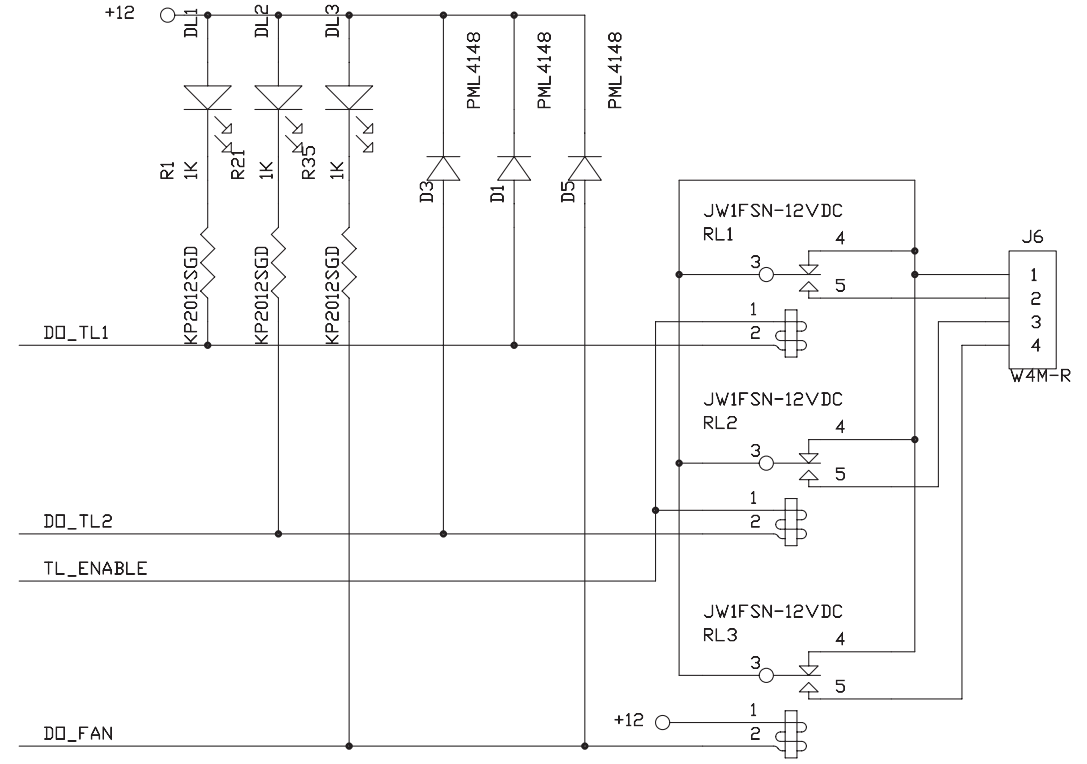
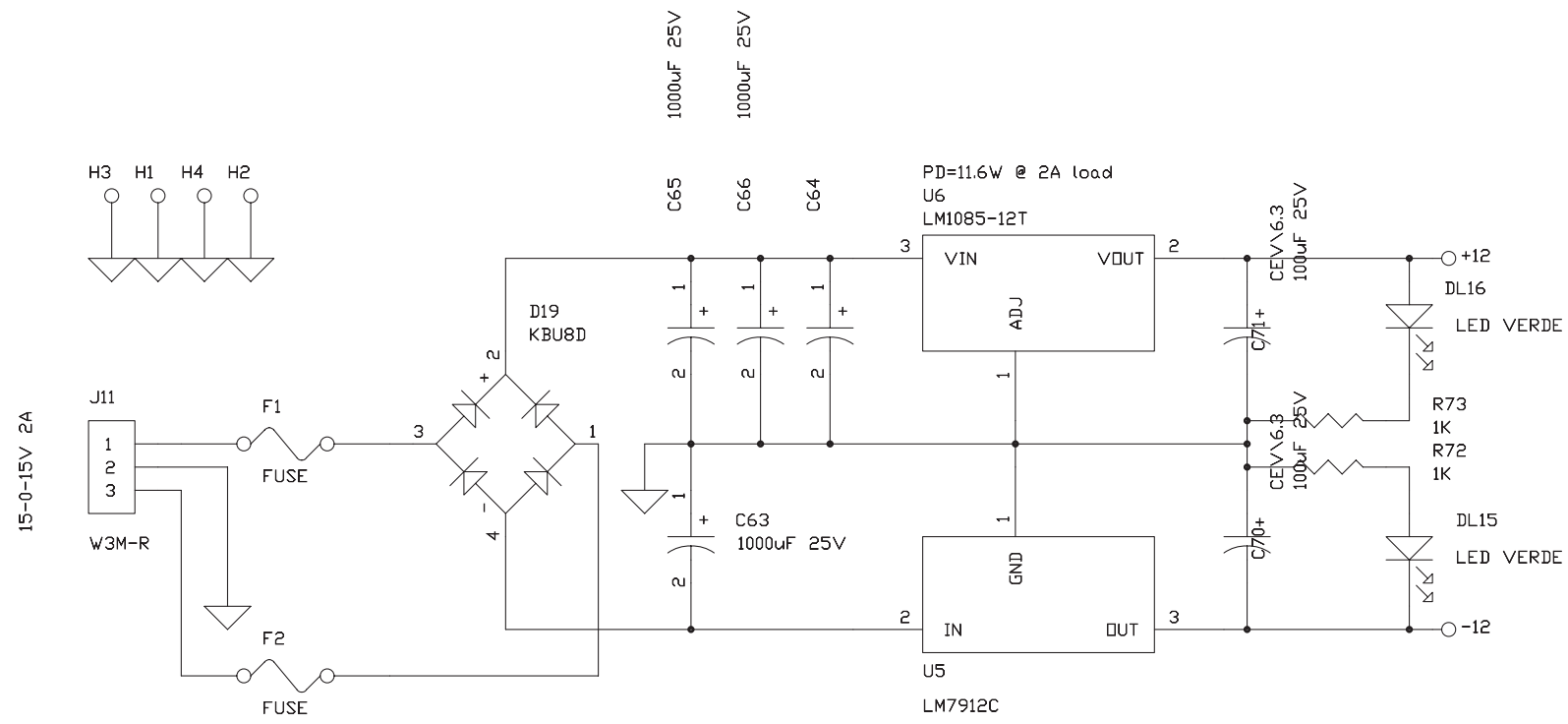

Thermal Meter & Th. sw.

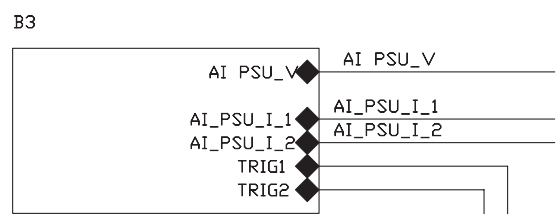

Voltage & Current Detectors

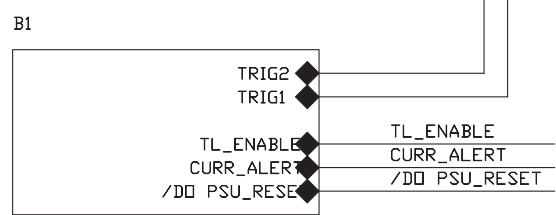

Current Alert

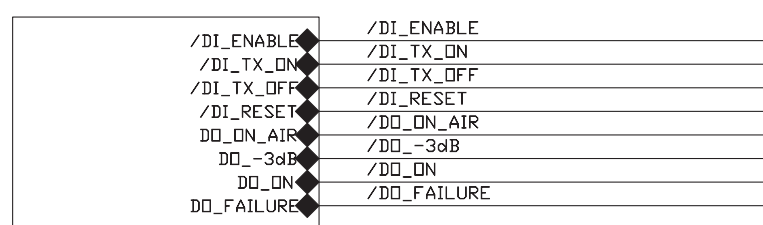

I-□ Interface
B4

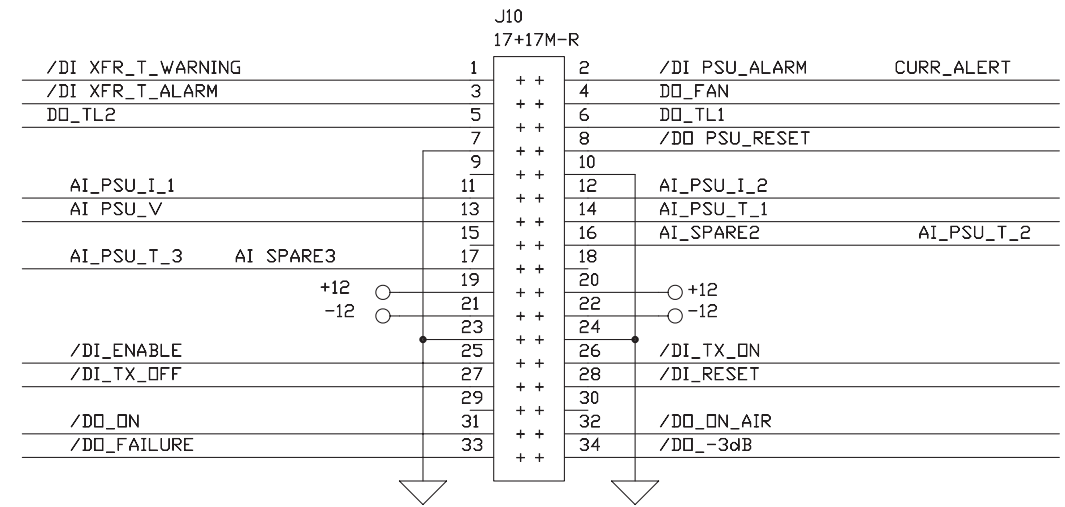

ELENOS	Via G. Amendola 9 44028 Poggio Renatico (FE) Italy		
	Tel +39 0532 829965 Fax +39 0532 829177		
			Website WWW.ELENOS.COM
Title: SERVICE POWER SUPPLY (LINEAR VERSION)			
Board Code: E2K 6A000_1	Model: E2500	Rev 1	
Proj. Engr. : A.Tomassini	Approved : A.Giovannelli		
Date: Wednesday, November 15, 2000	Sheet 1	of 5	

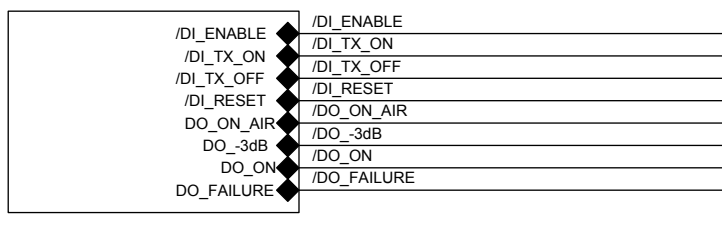
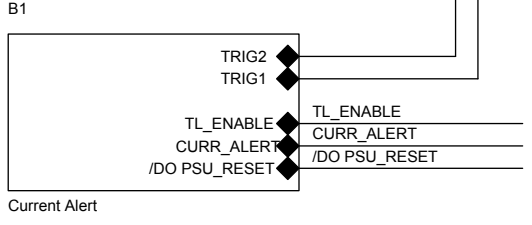
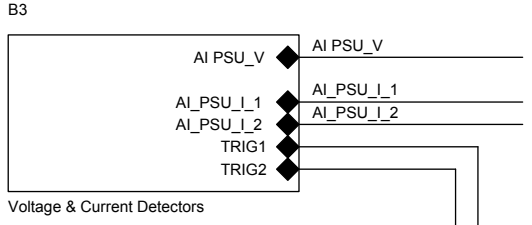
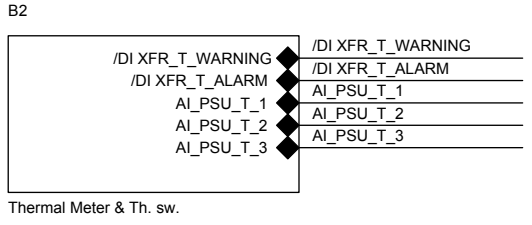
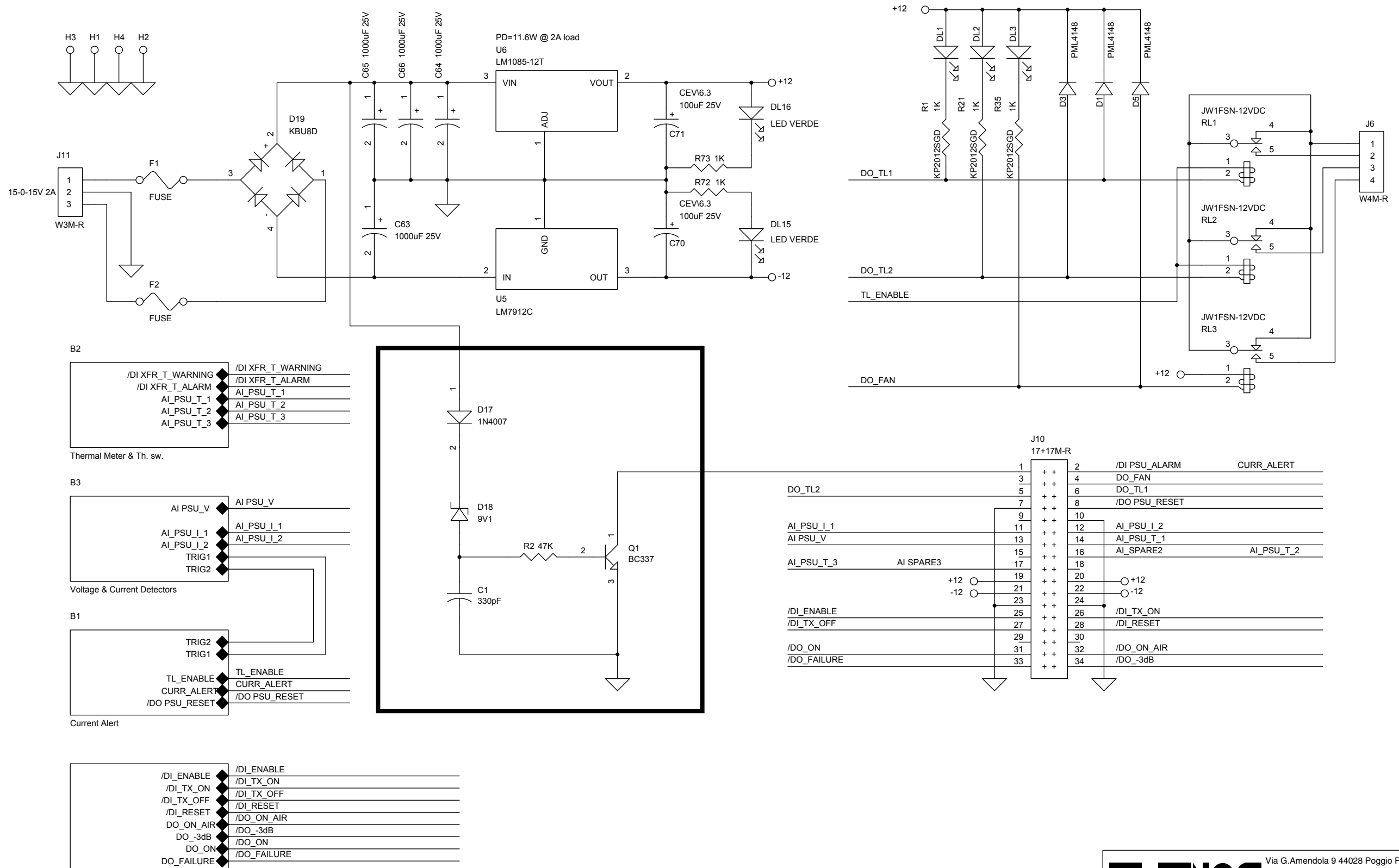

I/O Interface
B4

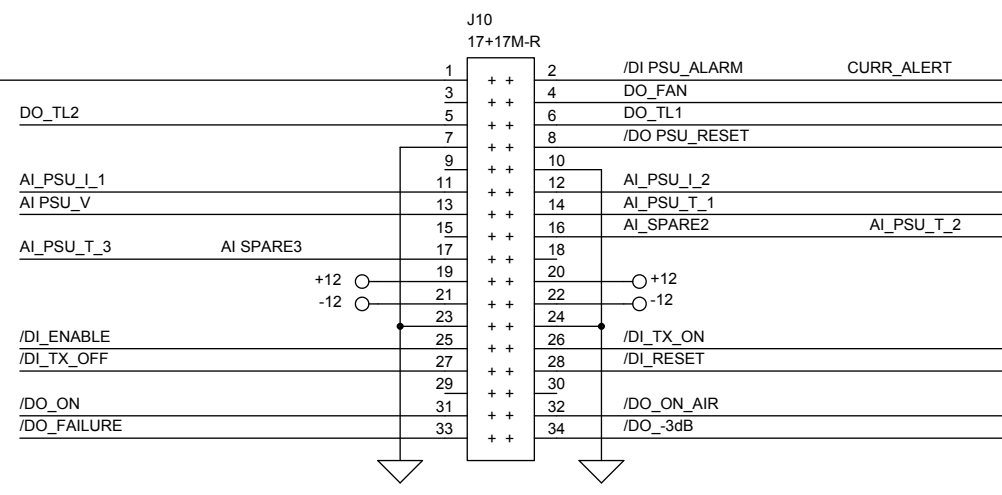

	Via G. Amendola 9 44028 Poggio Renatico (FE) Italy	
	Tel +39 0532 829965 Fax +39 0532 829177	
Website WWW.ELENOS.COM		
Title: SERVICE POWER SUPPLY (LINEAR VERSION)		
Board Code: E2K 6A000_2	Model: E2500	Rev 2
Proj. Engr. : A.Tomassini	Approved : A.Giovannelli	
Date: Friday, September 26, 2003	Sheet 1 of 5	

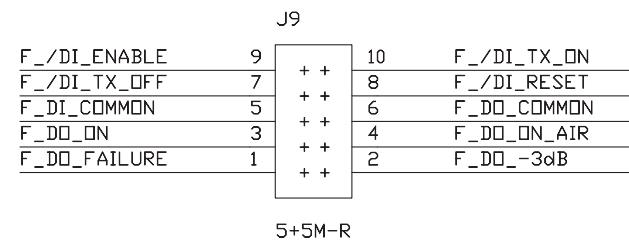
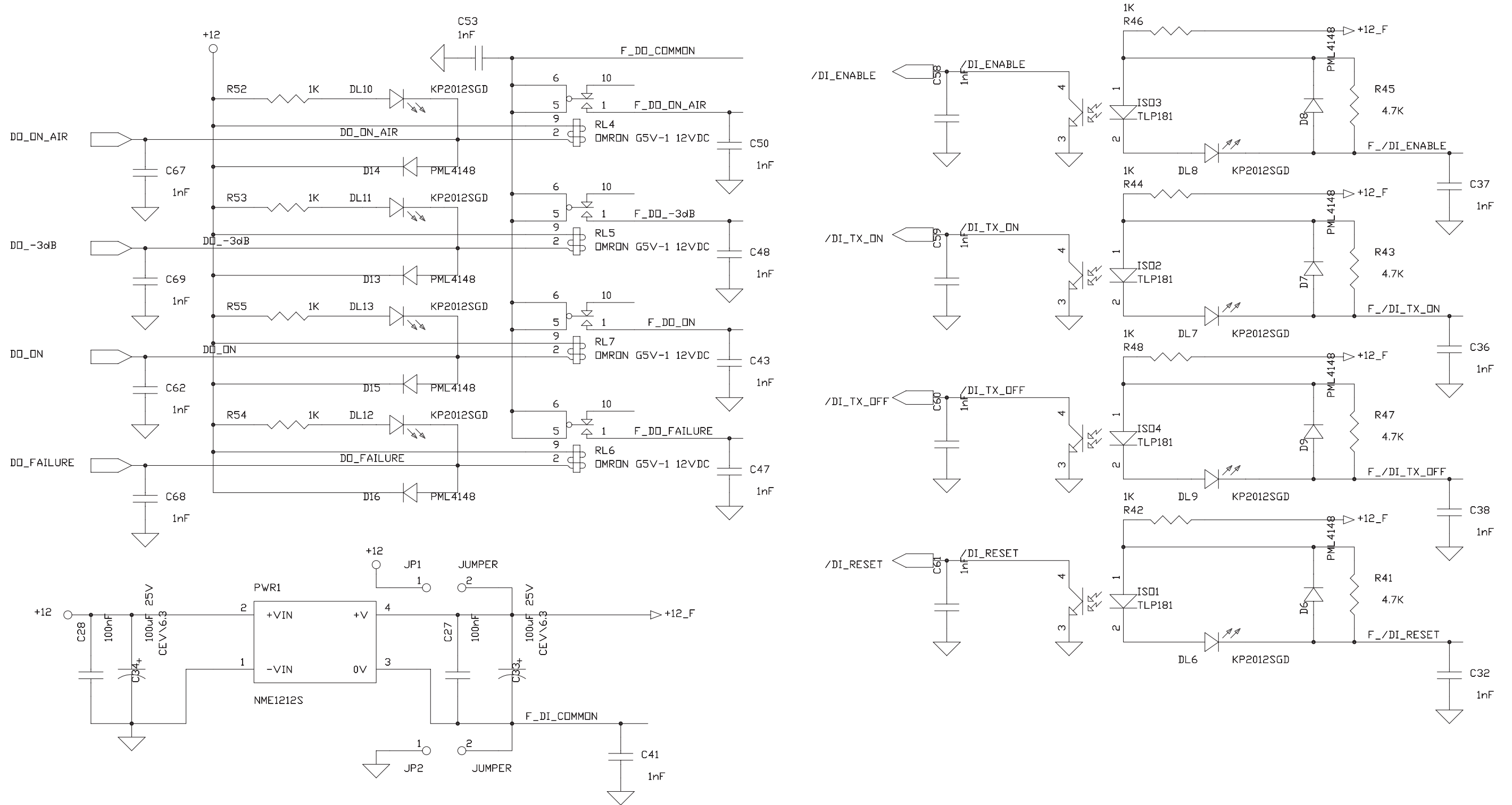

ELENOS Via G.Amendola 9 44028 Poggio Renatico (FE) Italy
Tel +39 0532 829965 Fax +39 0532 829177
Website WWW.ELENOS.COM

Title: **I/O USER INTERFACE (LINEAR VERSION)**

Board Code: E2K 6A000_1	Model: E2500	Rev 1
Proj. Engr. : A.Tomassini	Approved : A.Giovanelli	
Date: Wednesday, November 15, 2000	Sheet 3 of 5	

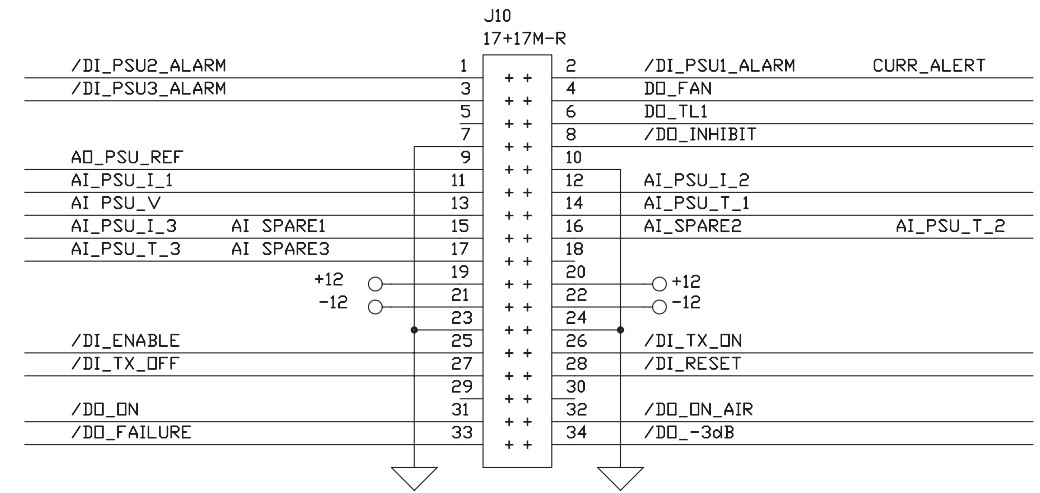
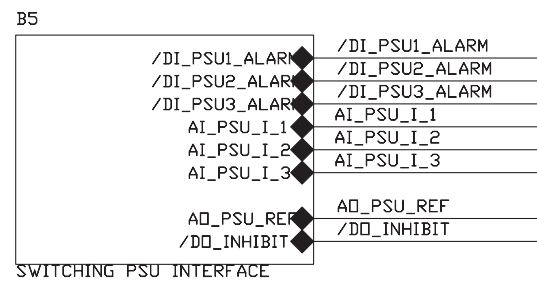
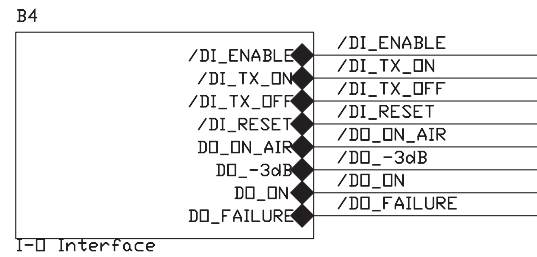
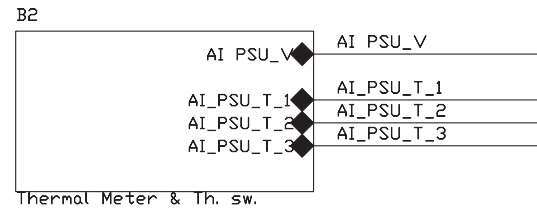
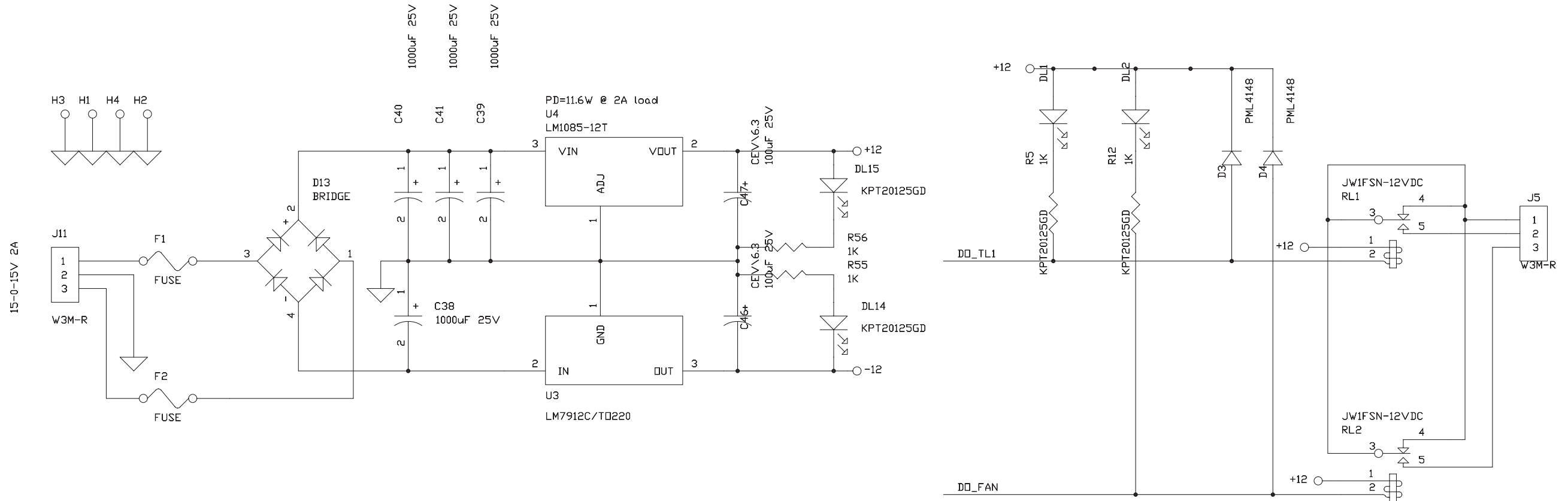

ELENOS Via G.Amendola 9 44028 Poggio Renatico (FE) Italy
Tel +39 0532 829965 Fax +39 0532 829177
Website WWW.ELENOS.COM

Title: **SERVICE POWER SUPPLY (SWITCHING VERSION)**

Board Code: E2K AA000_1	Model: E2500	Rev 1
Proj. Engr. : A.Tomassini	Approved : A.Giovannelli	
Date: Wednesday, November 15, 2000	Sheet 1 of 4	

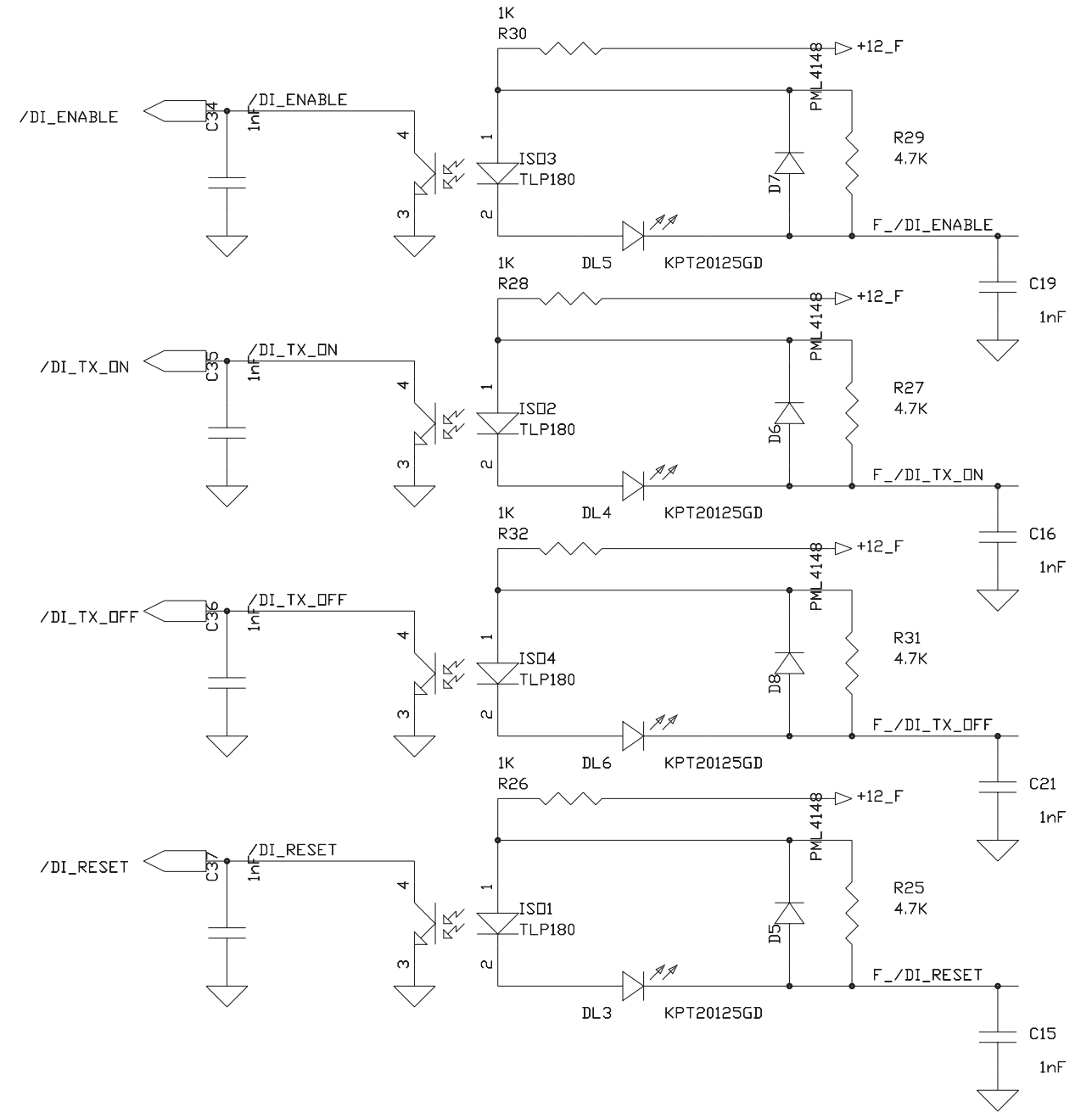
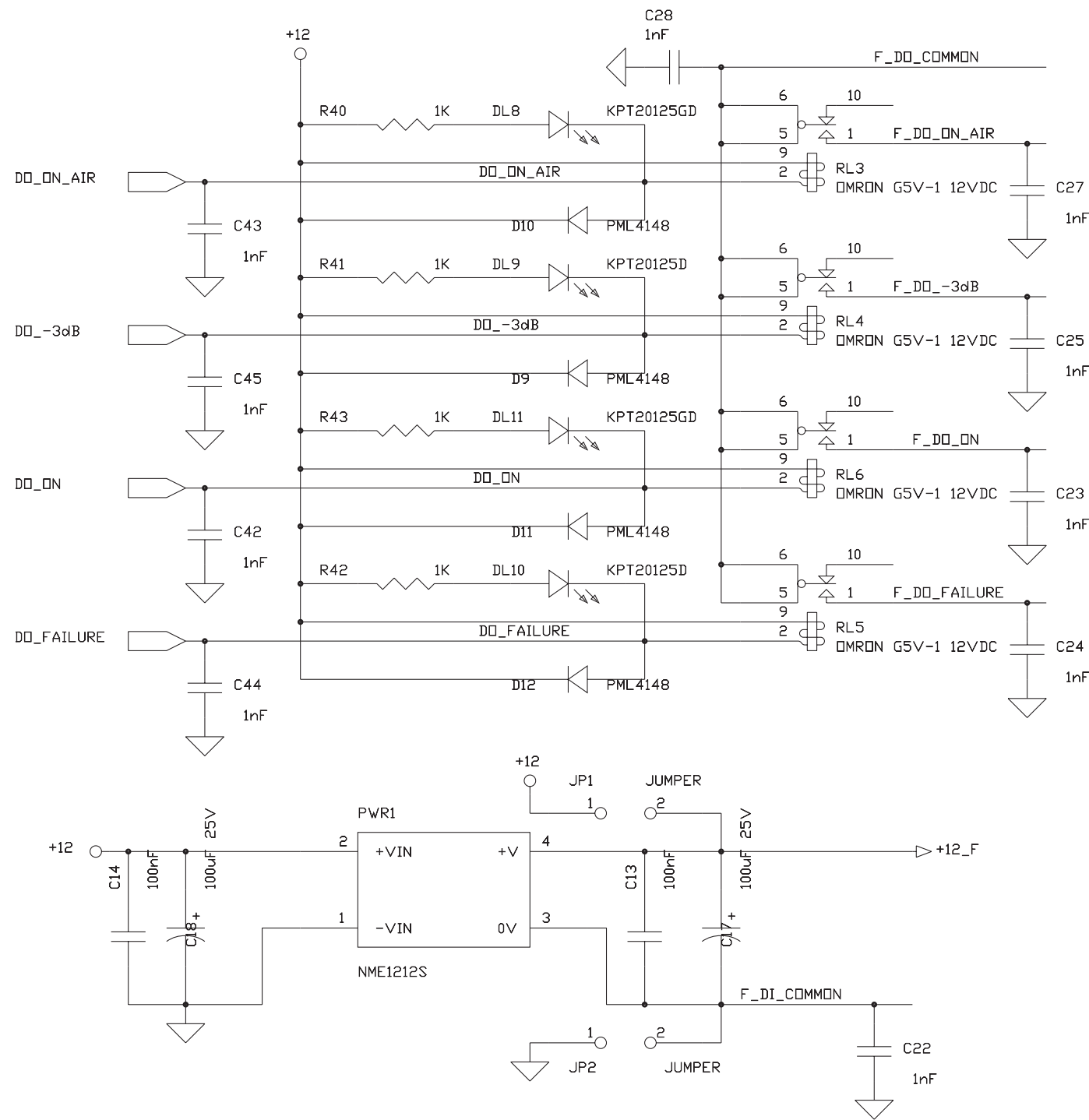

J9

F_/DI_ENABLE	9	10	F_/DI_TX_ON
F_/DI_TX_OFF	7	8	F_/DI_RESET
F_DI_COMMON	5	6	F_DD_COMMON
F_DD_ON	3	4	F_DD_ON_AIR
F_DD_FAILURE	1	2	F_DD_-3dB

5+5M-R

ELENOS Via G. Amendola 9 44028 Poggio Renatico (FE) Italy
Tel +39 0532 829965 Fax +39 0532 829177
Website WWW.ELENOS.COM

Title: **I/O USER INTERFACE (SWITCHING VERSION)**

Board Code: E2K AA000_1	Model: E2500	Rev 1
Proj. Engr. : A.Tomassini	Approved : A.Giovannelli	
Date: Wednesday, November 15, 2000	Sheet 2 of 4	

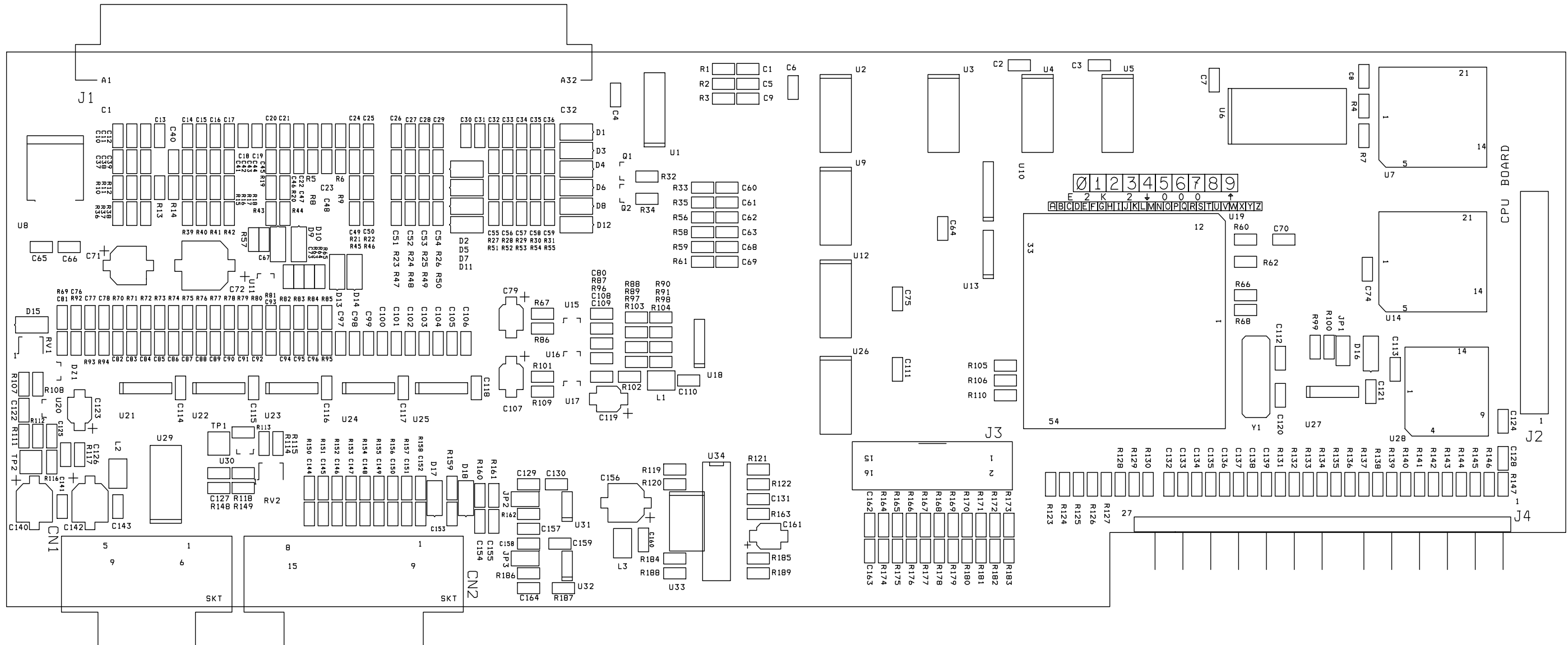

		Via G. Amendola 9 44028 Poggio Renatico (FE) Italy	
		Tel +39 0532 829965 Fax +39 0532 829177 Website WWW.ELENOS.COM	
Title: CPU BOARD			
Board Code: E2K 2A000_2	Model: E2500	Rev 2	
Proj. Engr. : A.Tomassini		Approved : A.Giovannelli	
Date: Friday, September 26, 2003	Sheet 1 of 1		

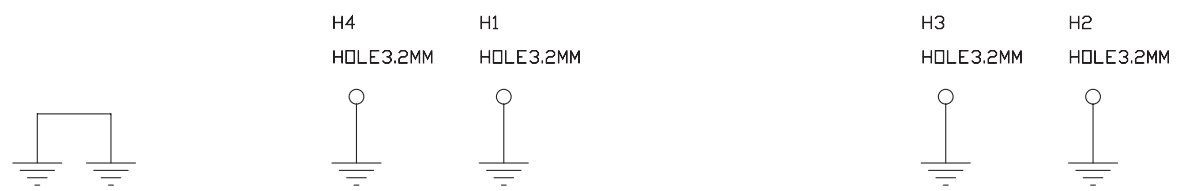
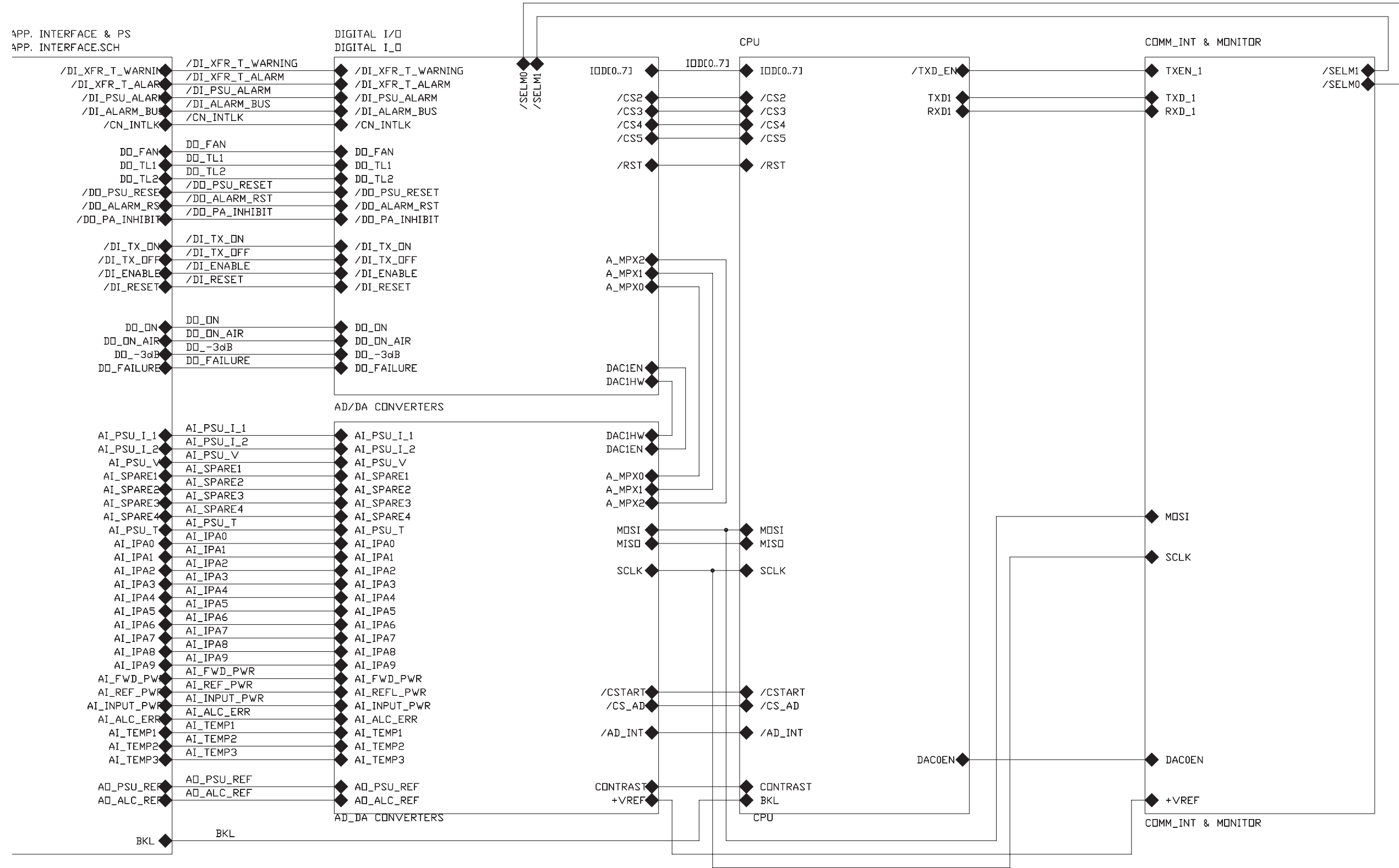

			Via G.Amendola 9 44028 Poggio Renatico (FE) Italy Tel +39 0532 829965 Fax +39 0532 829177 Website WWW.ELENOS.COM
Title: CPU BOARD BLOCK DIAGRAM			
Board Code: E2K 2A000_1	Model: E2500	Rev 2	
Proj. Engr. : A.Tomassini	Approved : A.Giovannelli		
Date: Wednesday, November 15, 2000	Sheet 1	of 6	

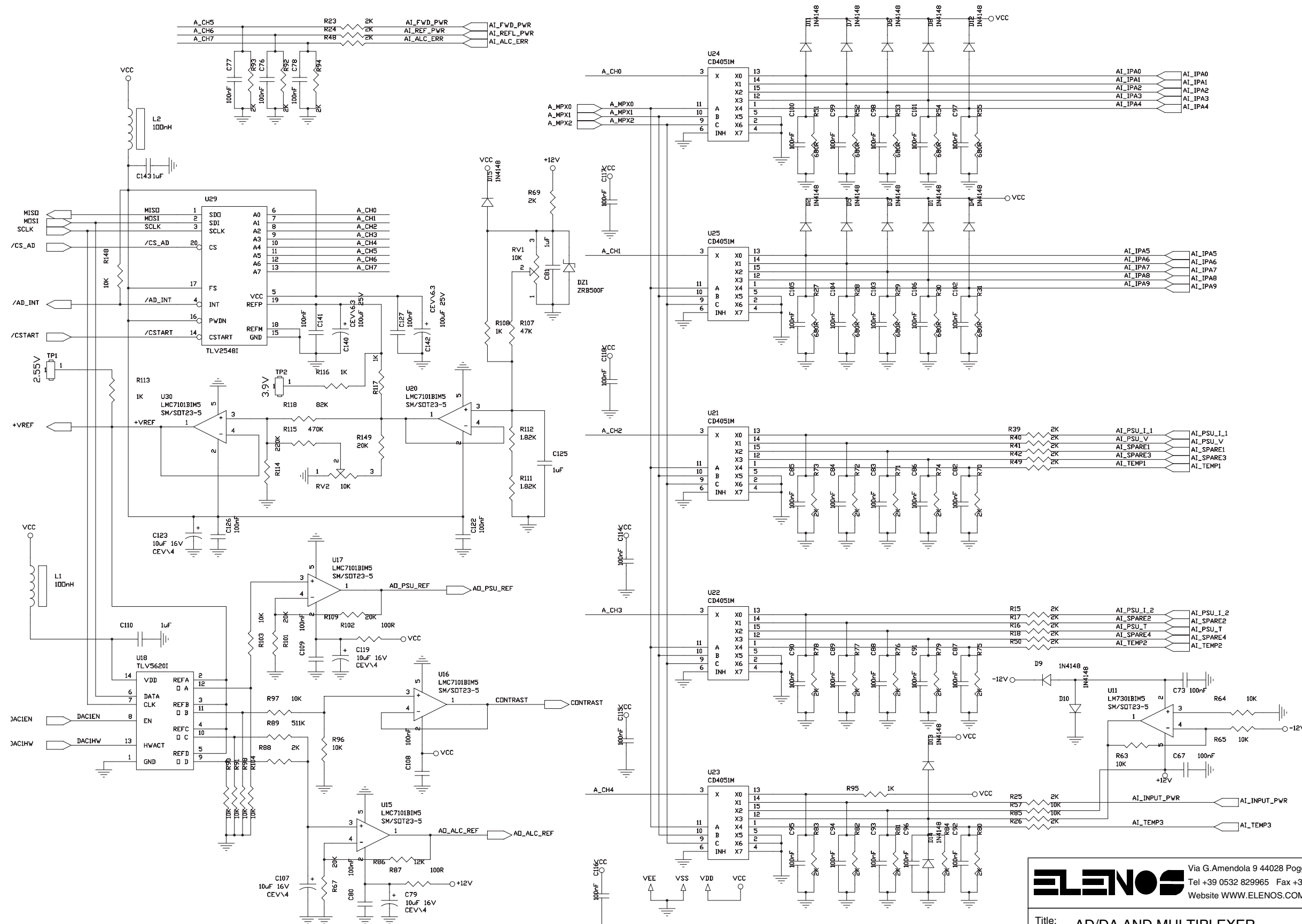

ELENOS Via G. Amendola 9 44028 Poggio Renatico (FE) Italy
Tel +39 0532 829965 Fax +39 0532 829177
Website WWW.ELENOS.COM

Title: **AD/DA AND MULTIPLEXER**

Board Code: E2K 2A000_1	Model: E2500	Rev 3
Proj. Engr. : A.Tomassini	Approved : A.Giovannelli	
Date: Wednesday, November 15, 2000	Sheet 2 of 6	

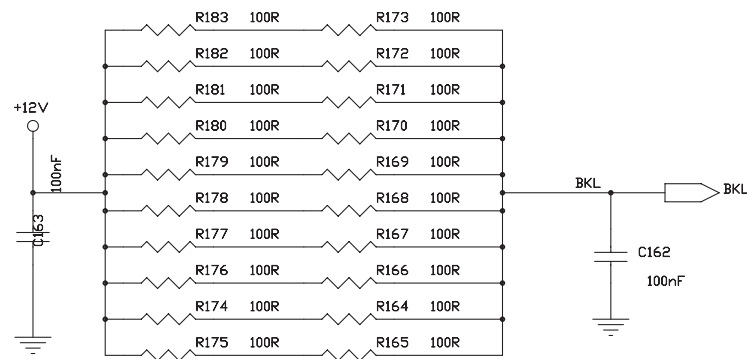
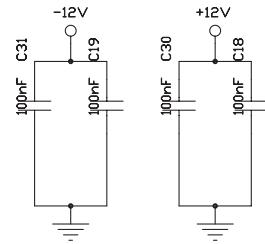
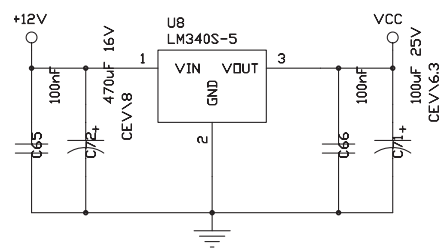
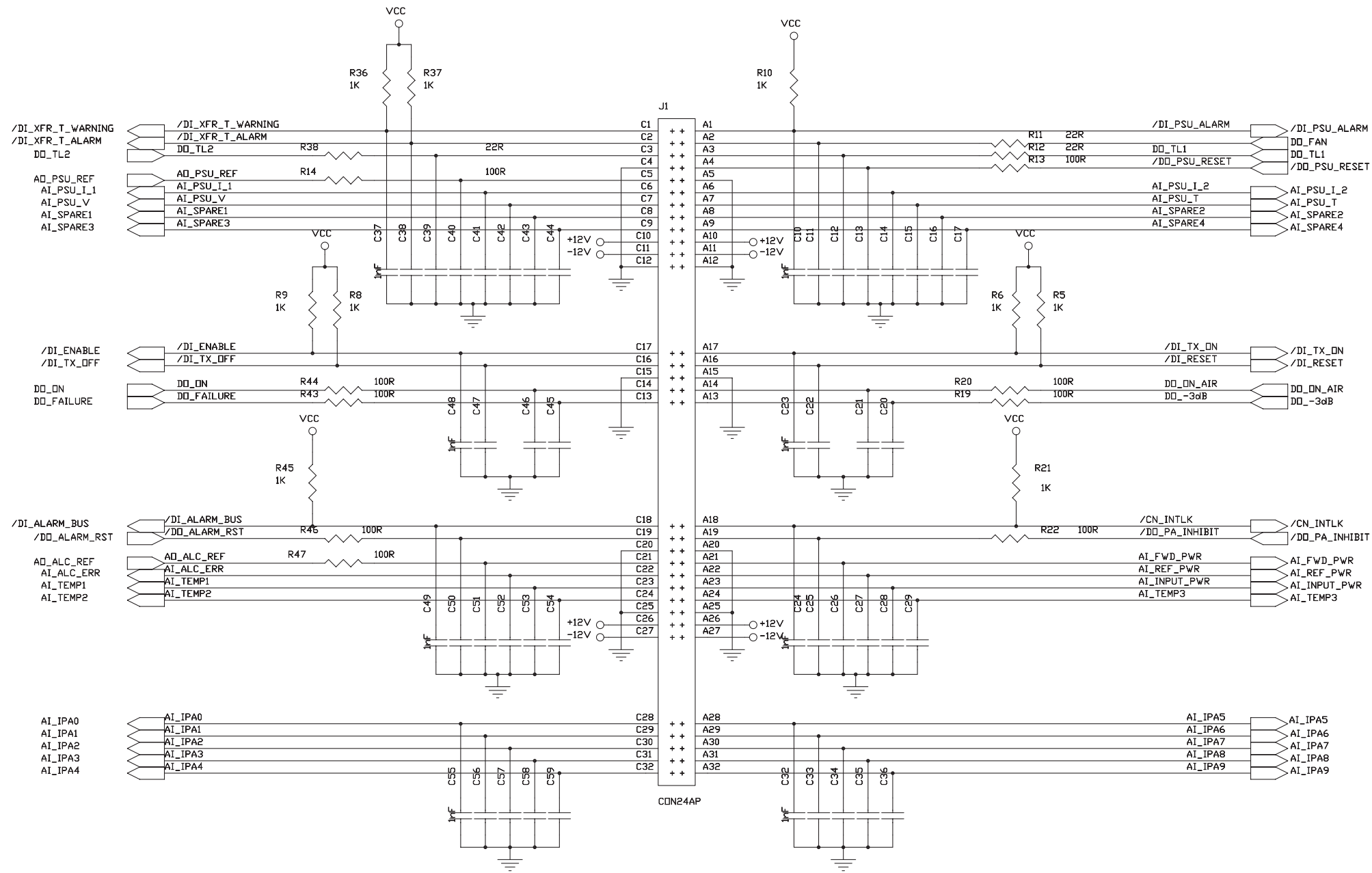

		Via G. Amendola 9 44028 Poggio Renatico (FE) Italy	
		Tel +39 0532 829965 Fax +39 0532 829177 Website WWW.ELENOS.COM	
Title: CPU BOARD CONNECTOR			
Board Code: E2K 2A000_1	Model: E2500	Rev 2	
Proj. Engr. : A.Tomassini	Approved : A.Giovannelli		
Date: Wednesday, November 15, 2000	Sheet 3	of 6	

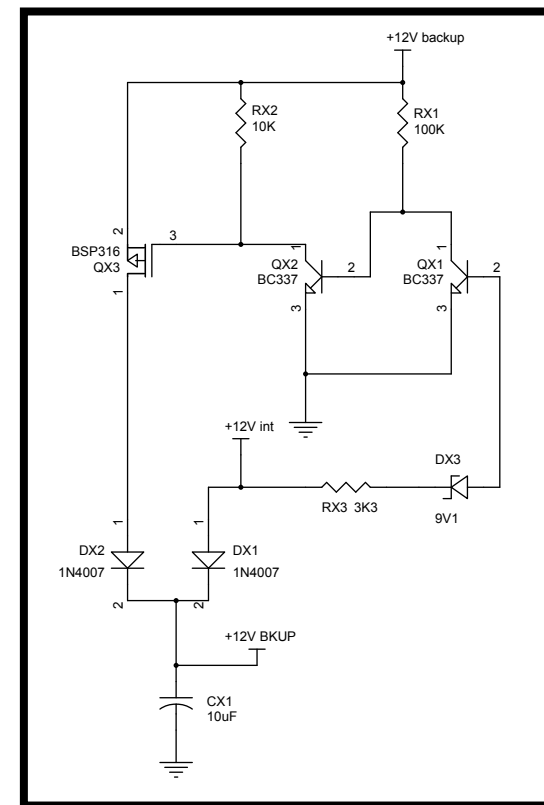
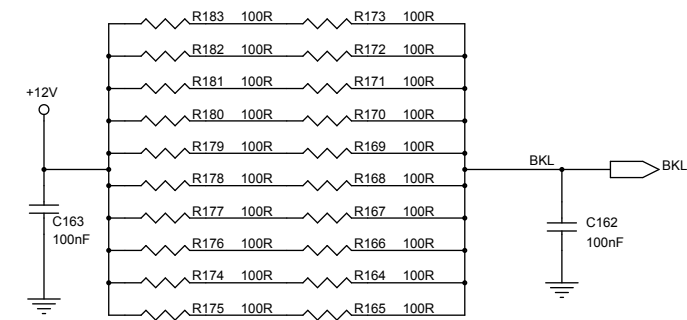
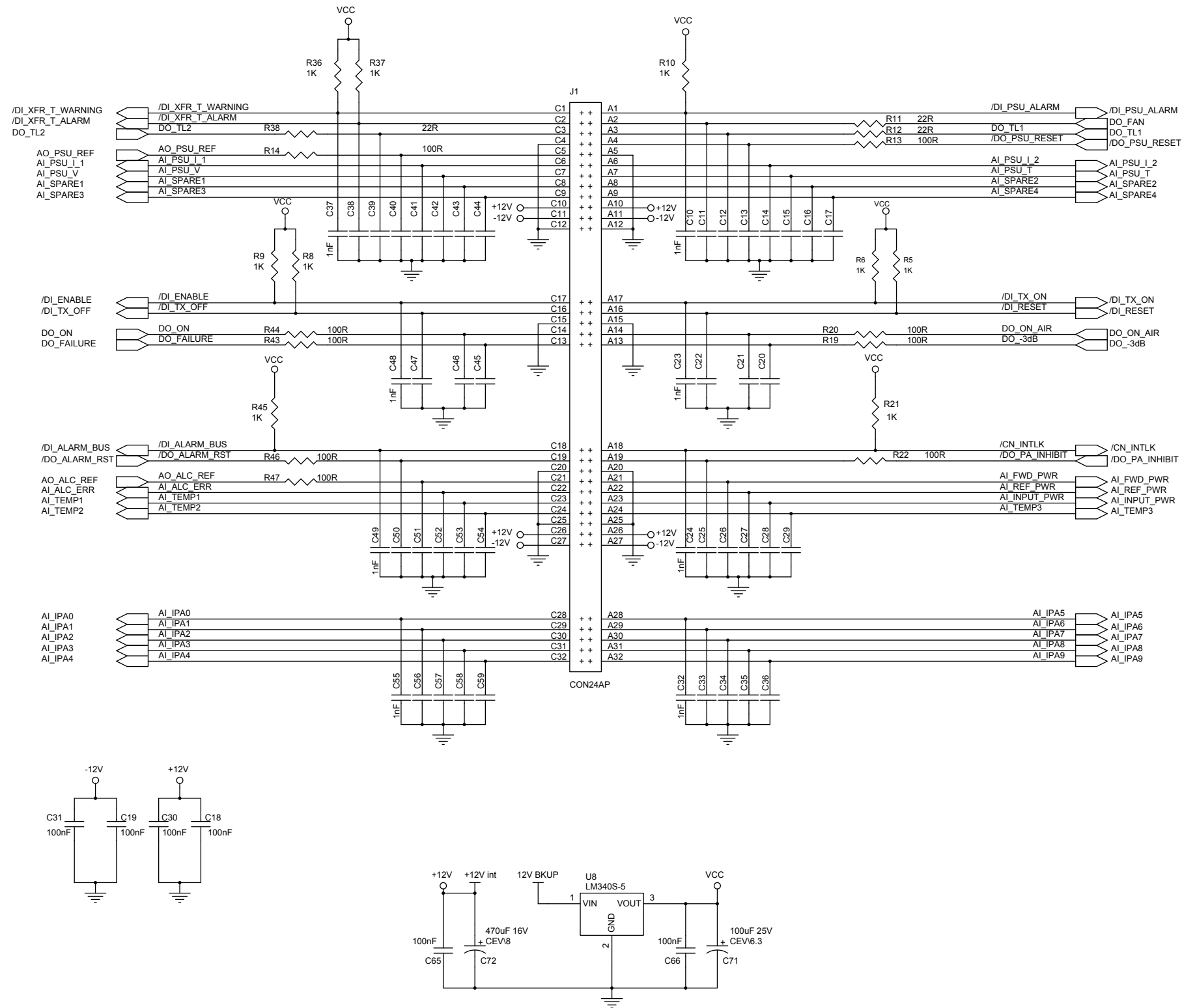

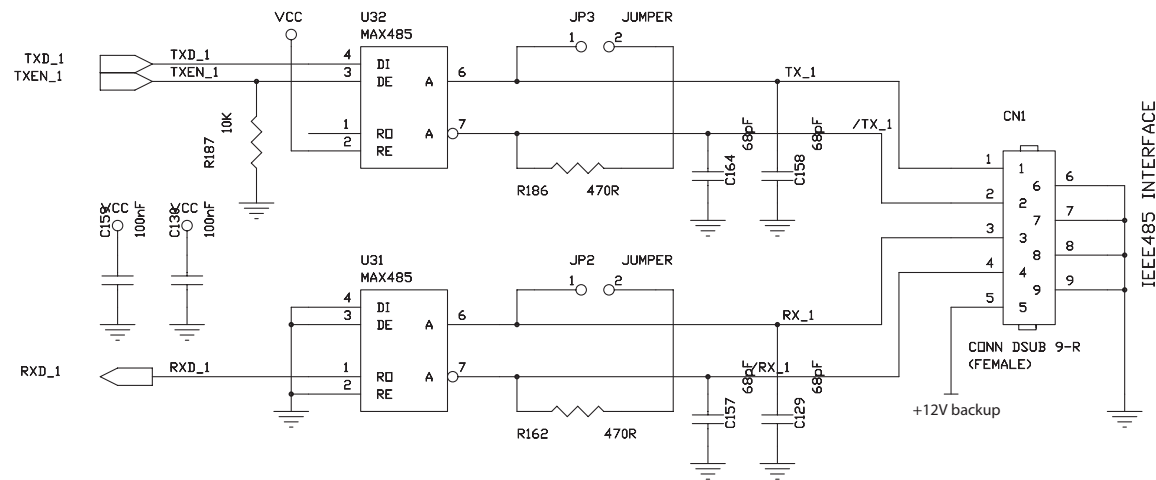
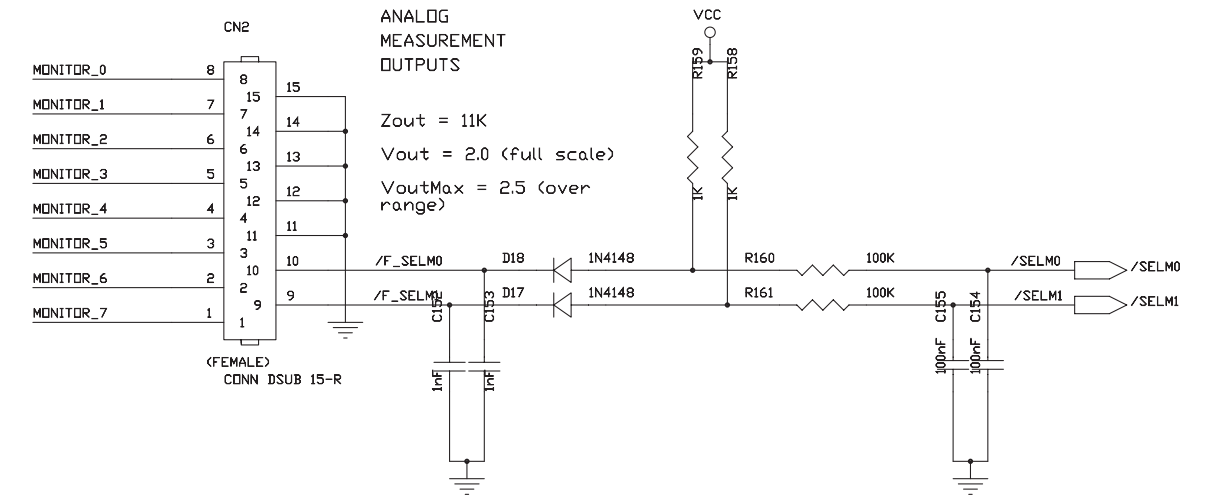
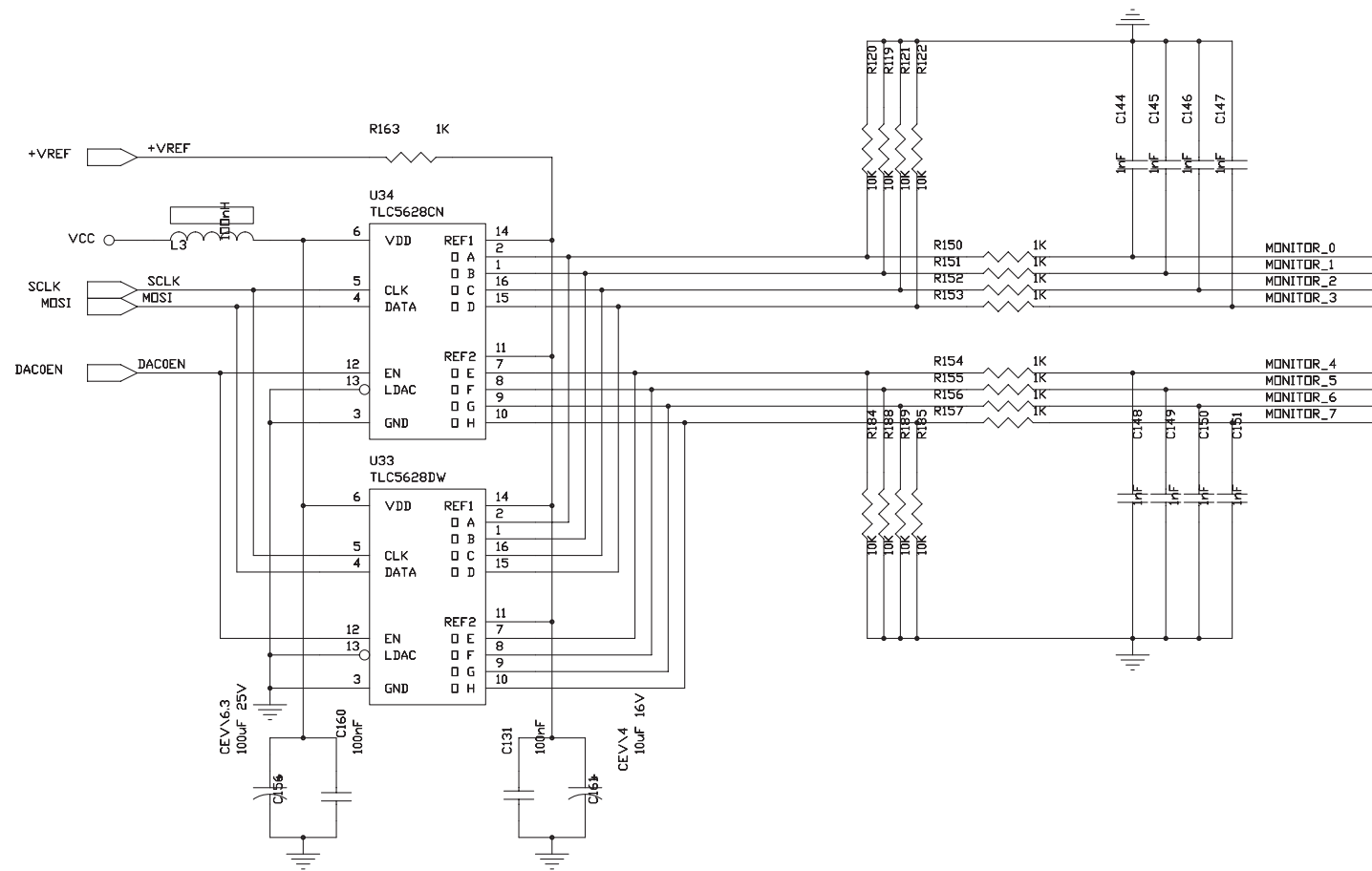

 Via G.Amendola 9 44028 Poggio Renatico (FE) Italy Tel +39 0532 829965 Fax +39 0532 829177 Website WWW.ELENOS.COM		
Title: RS485 AND ANALOG OUTPUTS		
Board Code: E2K 2A000_1	Model: E2500	Rev 2
Proj. Engr. : A.Tomassini	Approved : A.Giovannelli	
Date: Wednesday, November 15, 2000	Sheet 4	of 6

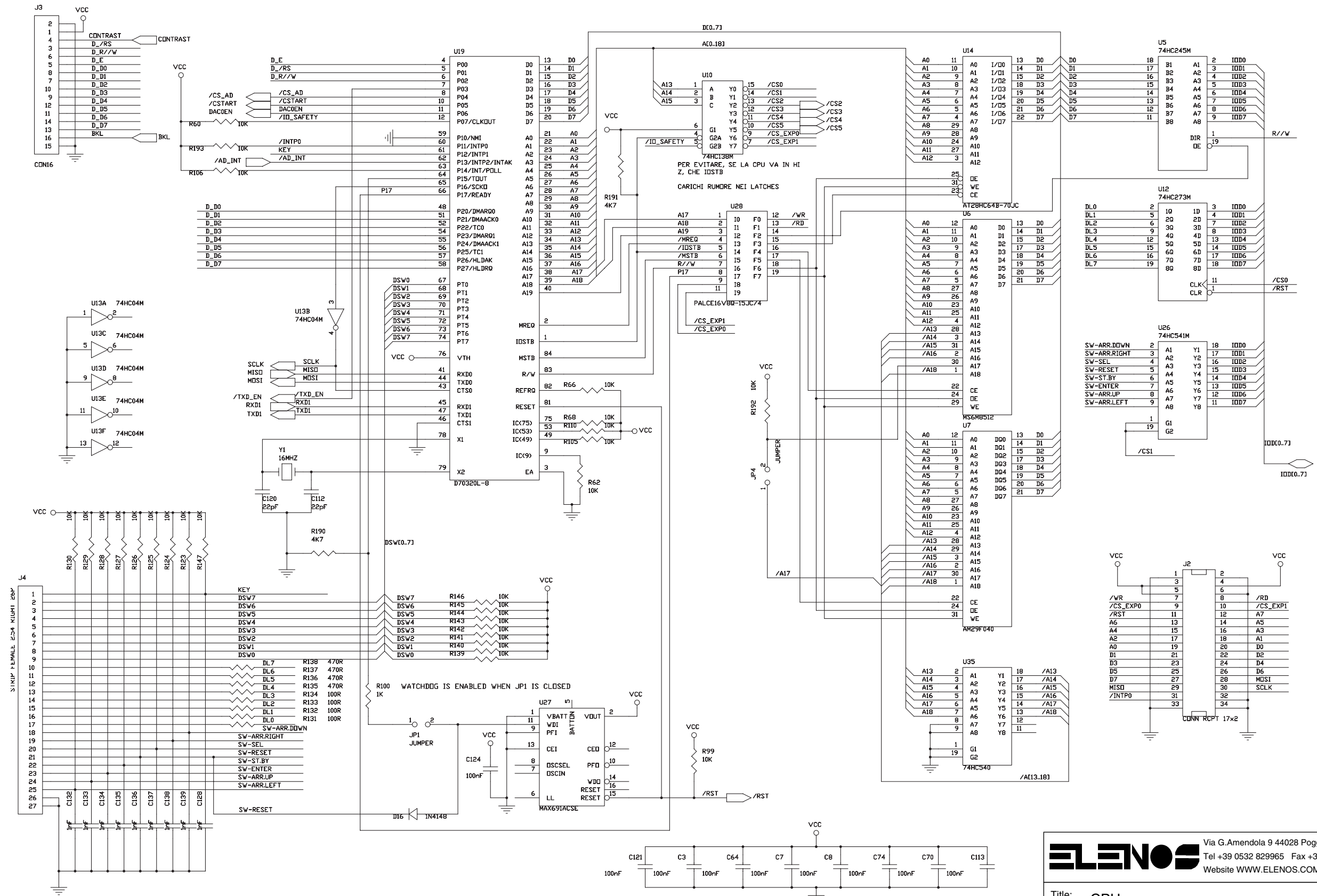

ELENOS Via G. Amendola 9 44028 Poggio Renatico (FE) Italy
Tel +39 0532 829965 Fax +39 0532 829177
Website WWW.ELENOS.COM

Title: CPU

Board Code: E2K 2A000_1	Model: E2500	Rev 3
Proj. Engr. : A.Tomassini	Approved : A.Giovannelli	
Date: Wednesday, November 15, 2000	Sheet 5 of 6	

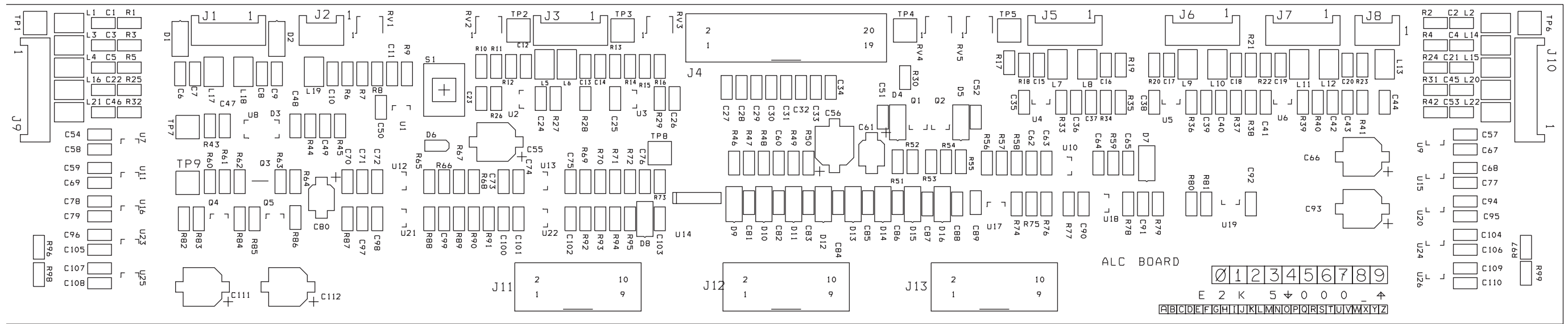

 Via G. Amendola 9 44028 Poggio Renatico (FE) Italy Tel +39 0532 829965 Fax +39 0532 829177 Website WWW.ELENOS.COM		
Title: ALC		
Board Code: E2K 5A000_1	Model: E2500	Rev 1
Proj. Engr. : A.Tomassini	Approved : A.Giovannelli	
Date: Wednesday, November 15, 2000	Sheet 1 of 1	

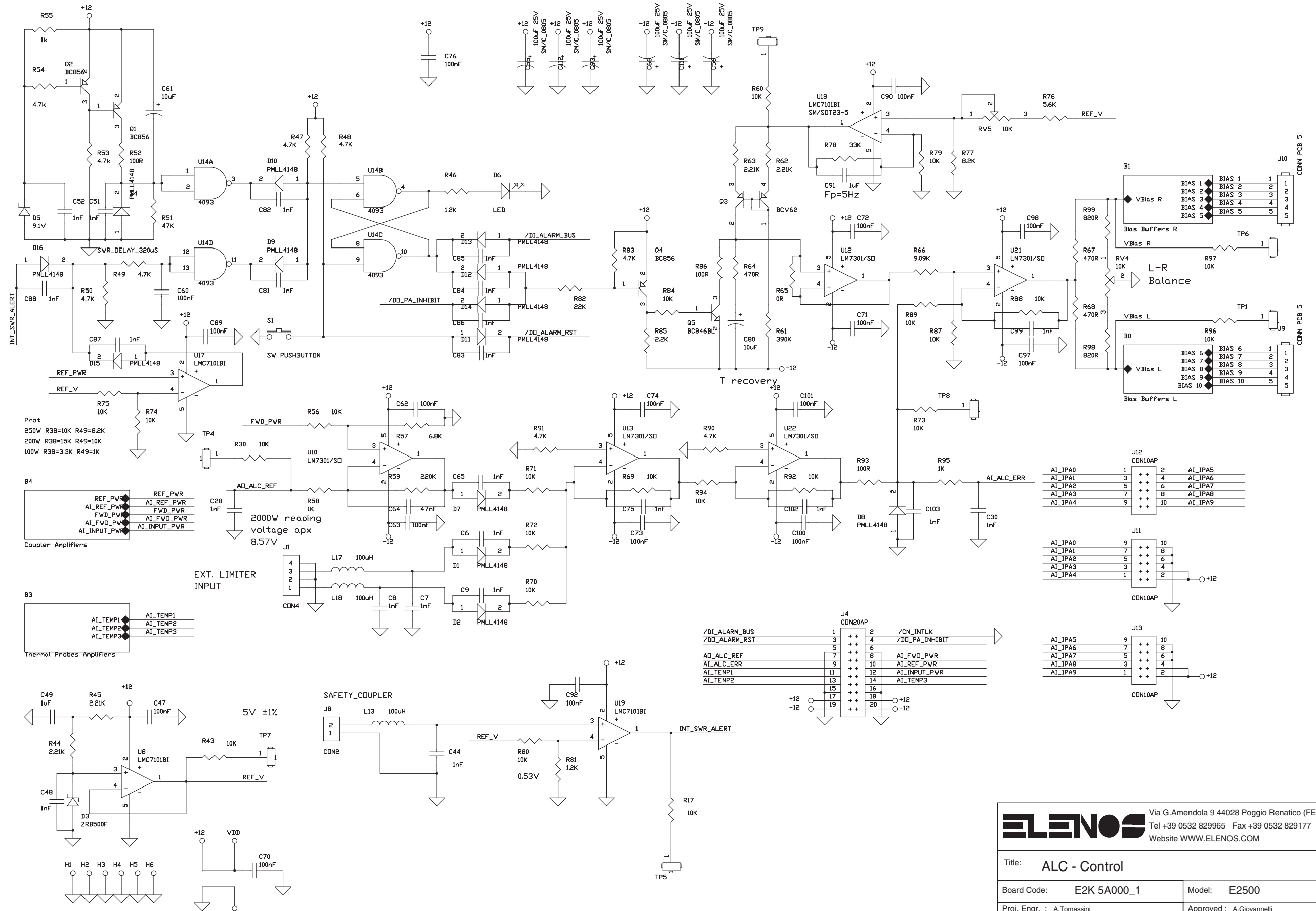

ELENOS Via G.Amendola 9 44028 Poggio Renatico (FE) Italy
Tel +39 0532 829965 Fax +39 0532 829177
Website WWW.ELENOS.COM

Title: **ALC - Control**

Board Code: E2K 5A000_1	Model: E2500	Rev 1
Proj. Engr. : A.Tomassini	Approved : A.Giovannelli	
Date: Wednesday, November 15, 2000	Sheet 1 of 5	

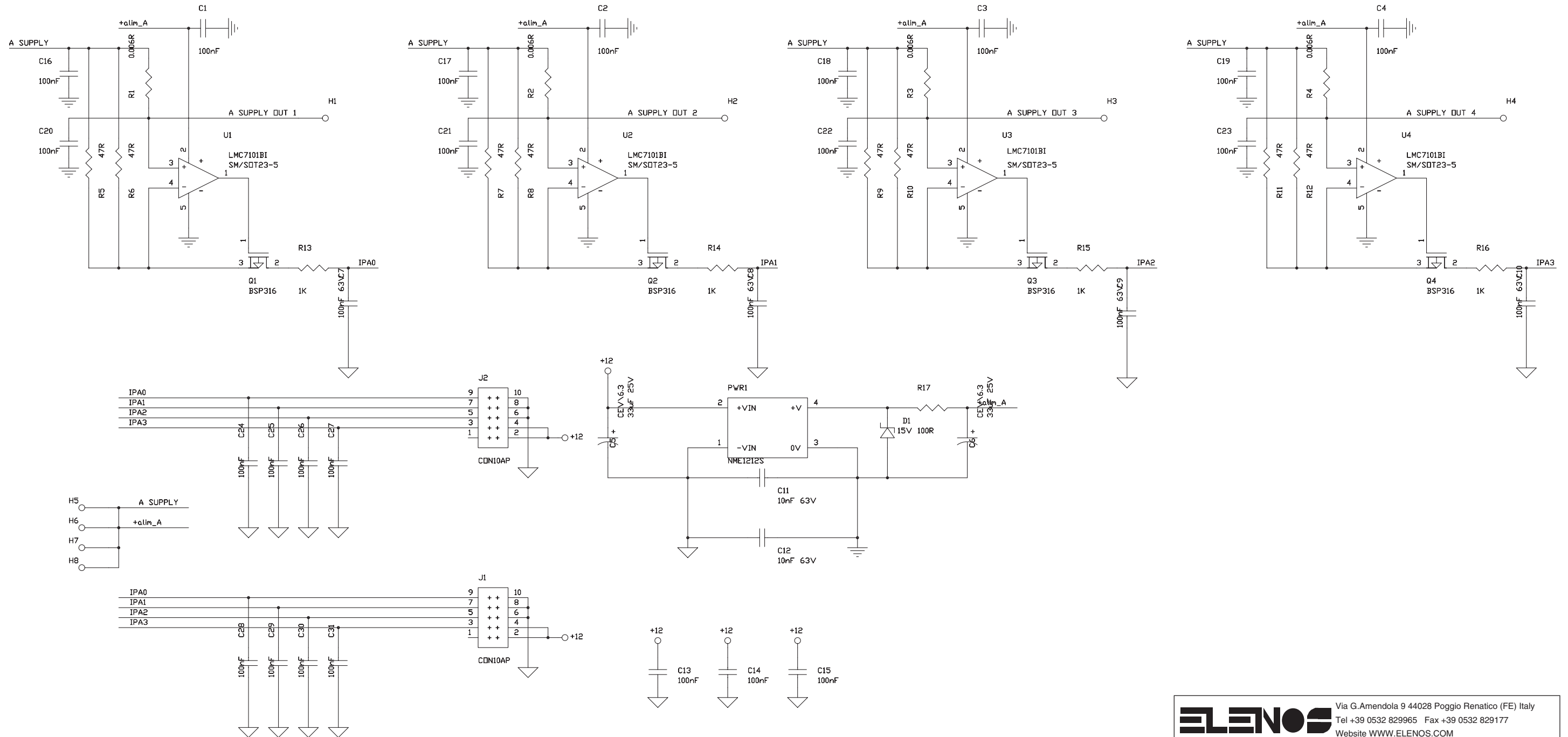

 Via G. Amendola 9 44028 Poggio Renatico (FE) Italy Tel +39 0532 829965 Fax +39 0532 829177 Website WWW.ELENOS.COM		
Title: CURRENT SENSOR		
Board Code: E2K 3A000_1	Model: E2500	Rev 1
Proj. Engr. : A.Tomassini	Approved : A.Giovannelli	
Date: Wednesday, November 15, 2000	Sheet 1	of 1