

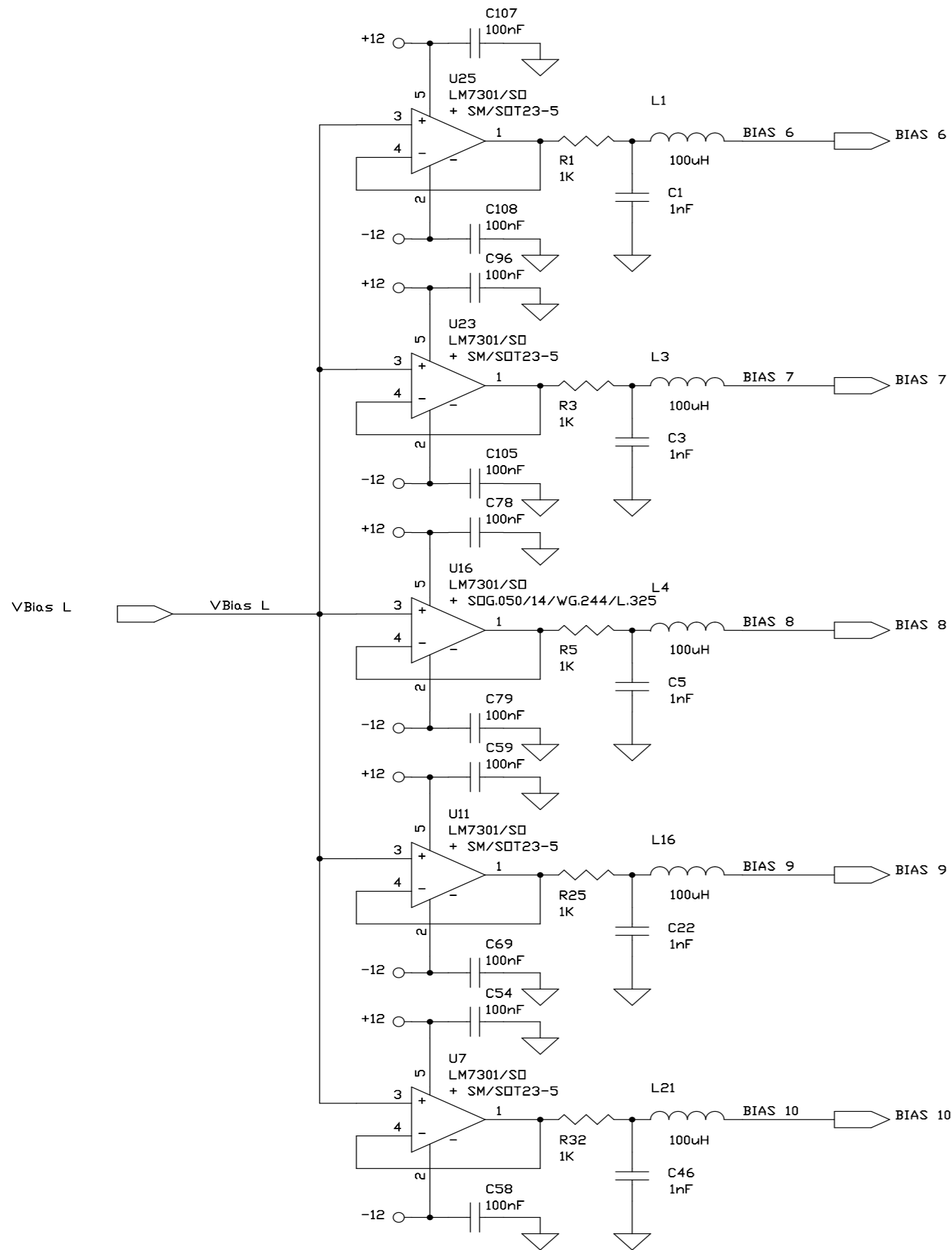



		Via G.Amendola 9 44028 Poggio Renatico (FE) Italy	
		Tel +39 0532 829965 Fax +39 0532 829177 Website WWW.ELENOS.COM	
Title: ALC-CONTROL			
Board Code: PCB0264_1	Model: 5K AA021_1	Rev 1	
Proj. Engr: Tomassini	Approve: Giovannelli		
Date: Monday, December 13, 2004	Sheet 1	of 5	



 Via G.Amendola 9 44028 Poggio Renatico (FE) Italy Tel +39 0532 829965 Fax +39 0532 829177 Website WWW.ELENOS.COM		
Title: ALC-BIAS BUFFERS-A		
Board Code: 2PCB0264_1	Model: E2K 5A021_1	Rev 1
Proj. Engr. A.Tomassini	Approved : A.Giovanelli	
Date: Monday, December 13, 2004	Sheet 2	of 5

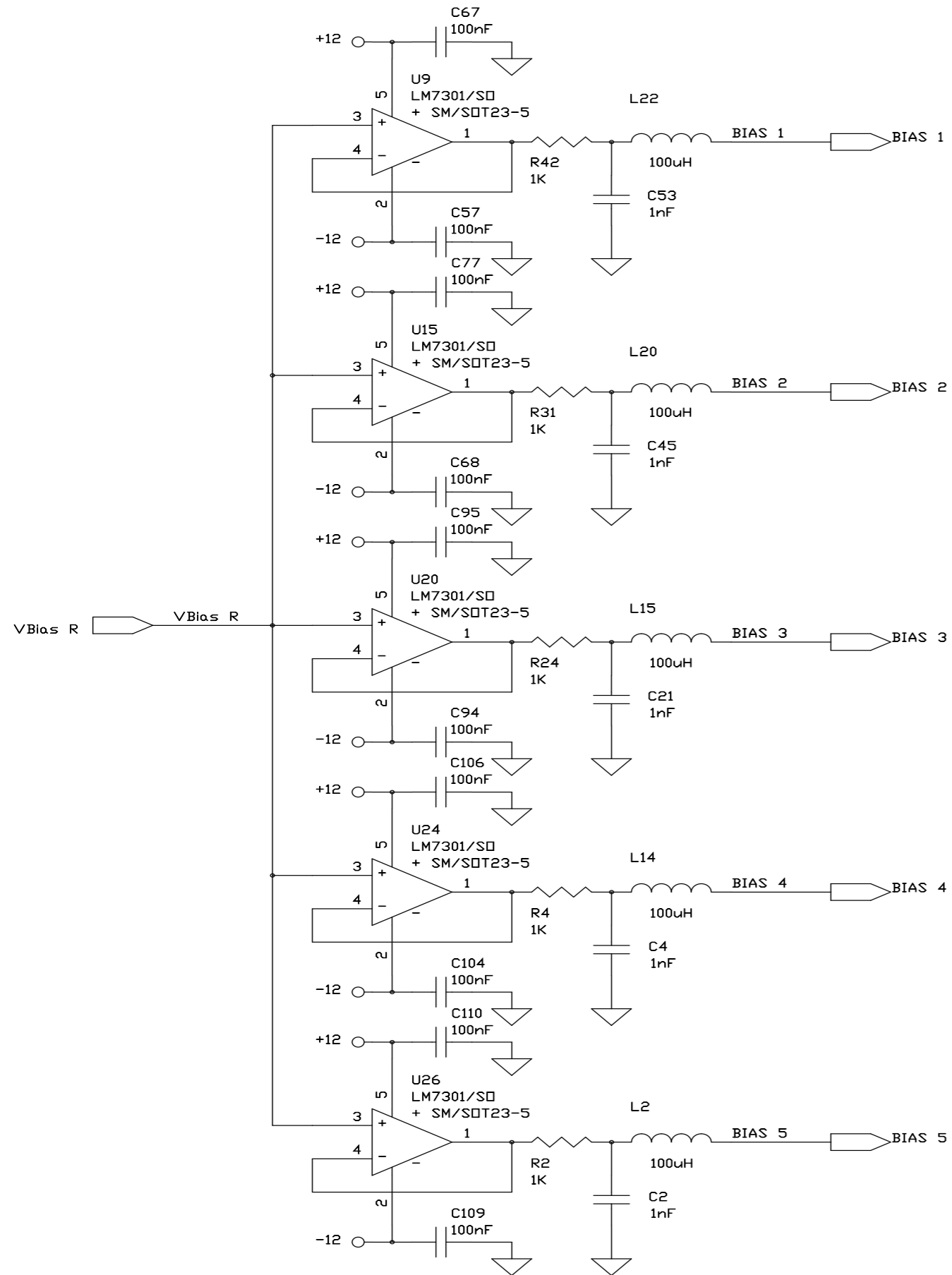

 Via G.Amendola 9 44028 Poggio Renatico (FE) Italy Tel +39 0532 829965 Fax +39 0532 829177 Website WWW.ELENOS.COM		
Title: ALC-BIAS BUFFERS-B		
Board Code: PCB0264_1	Model: E5K AA021_1	Rev 1
Proj. Engr. A.Tomassini	Approved A.Giovannelli	
Date: Monday, December 13, 2004	Sheet 3 of 5	

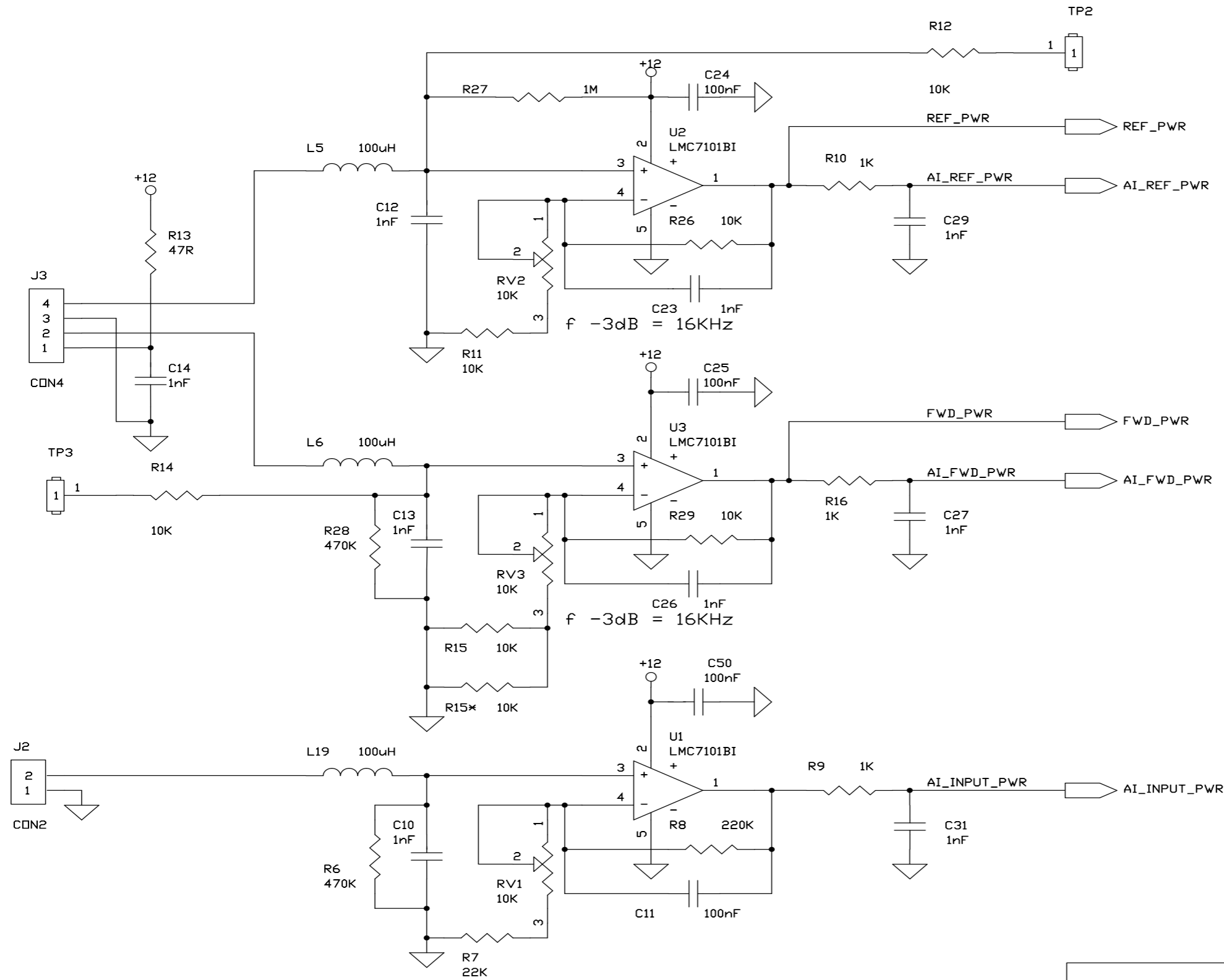

ELENOS Via G.Amendola 9 44028 Poggio Renatico (FE) Italy
Tel +39 0532 829965 Fax +39 0532 829177
Website WWW.ELENOS.COM

Title: POWER MEASURE AMPLIFIERS		
Board Code: 2PCB0264_1	Model: E5K AA021_1	Rev 1
Proj. Engr. A.Tomassini	Approved : A.Gioannelli	
Date: Monday, December 13, 2004	Sheet 4	of 5

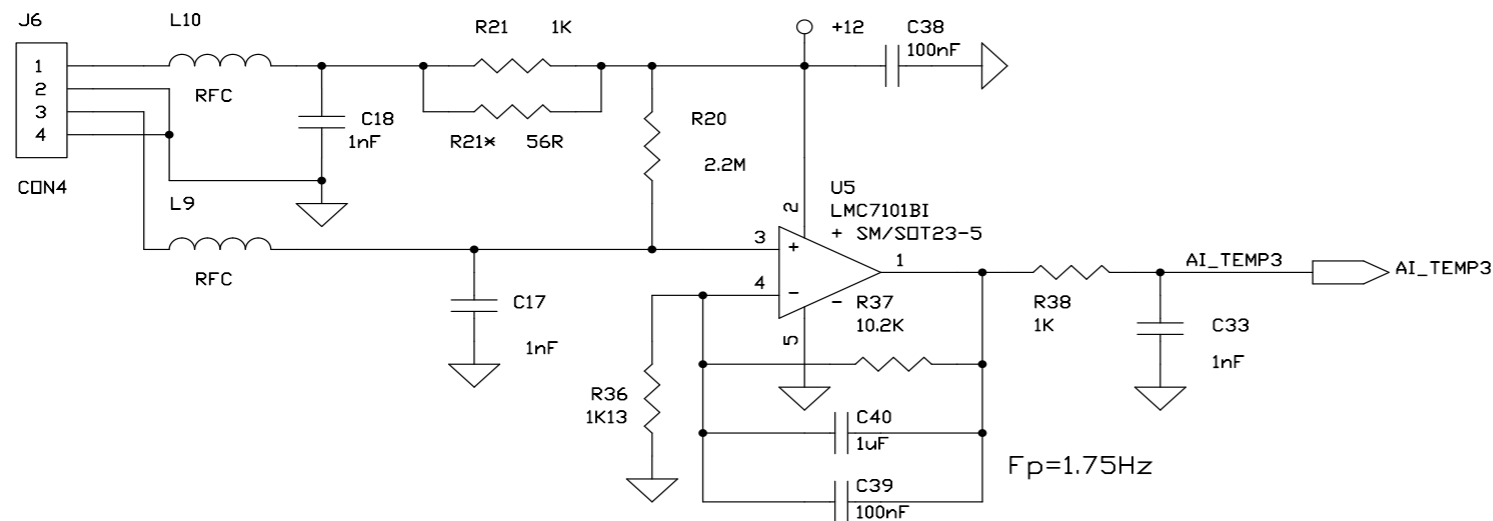
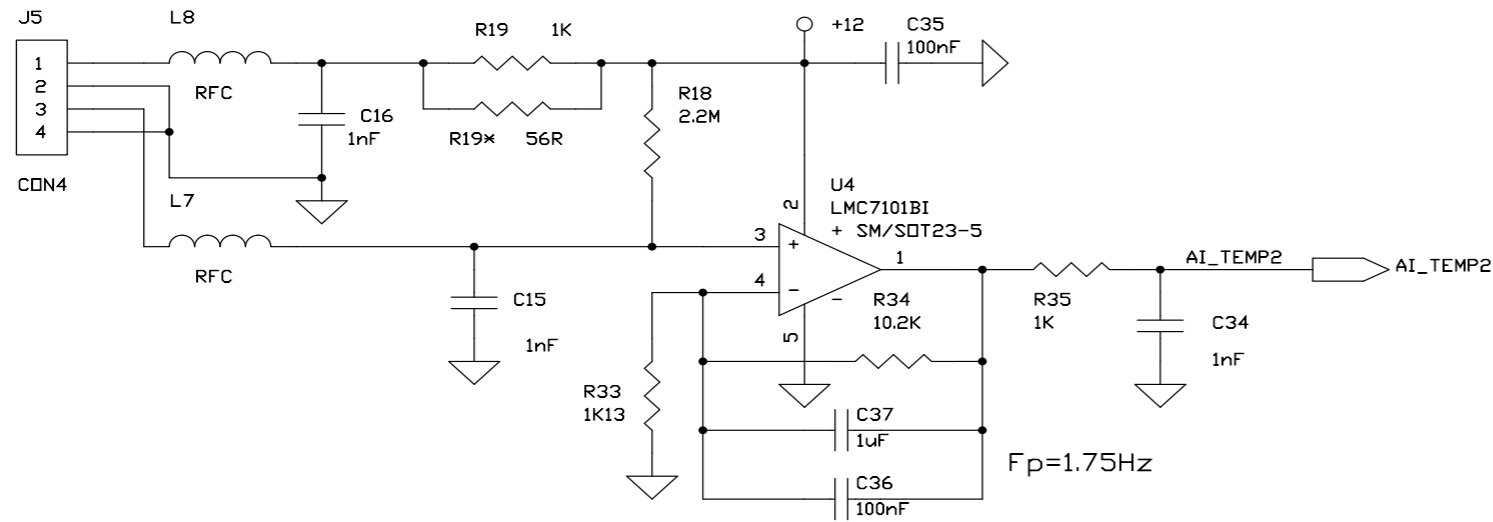
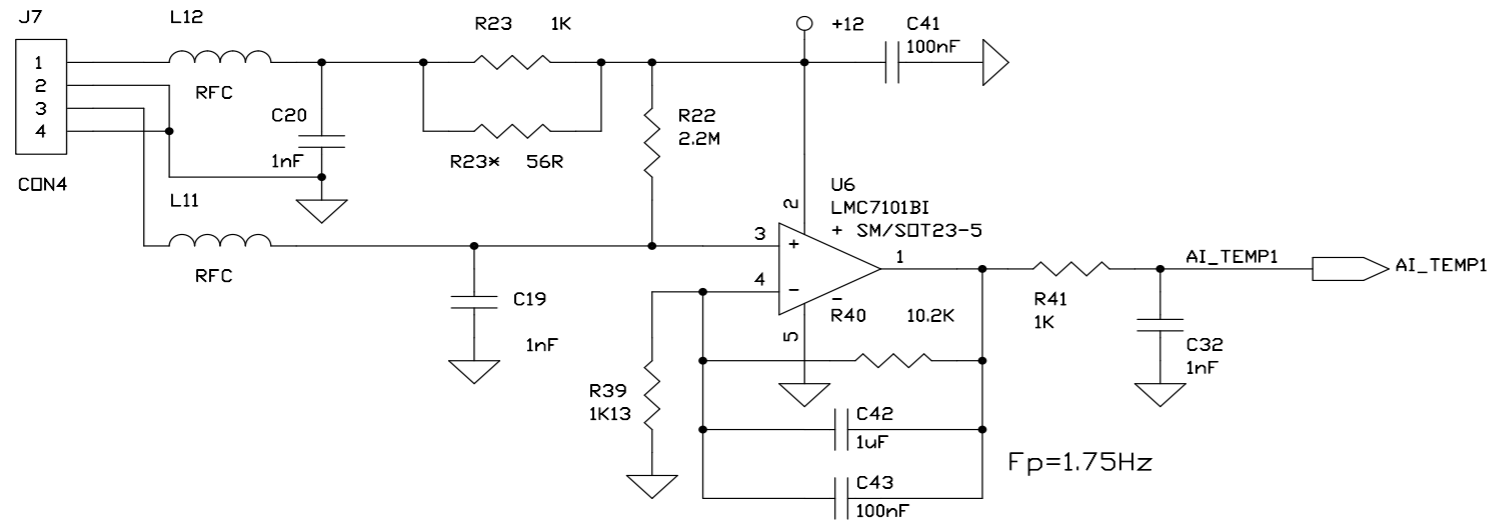

ELENOS Via G.Amendola 9 44028 Poggio Renatico (FE) Italy
Tel +39 0532 829965 Fax +39 0532 829177
Website WWW.ELENOS.COM

Title: ALC-THERMAL MEASURE AMPLIFIERS		
Board Code: 2PCB0264_1	Model: E5K AA021_1	Rev 1
Proj. Engr. A.Tomassini	Approved: A.Giovanelli	
Date: Monday, December 13, 2004	Sheet 5	of 5

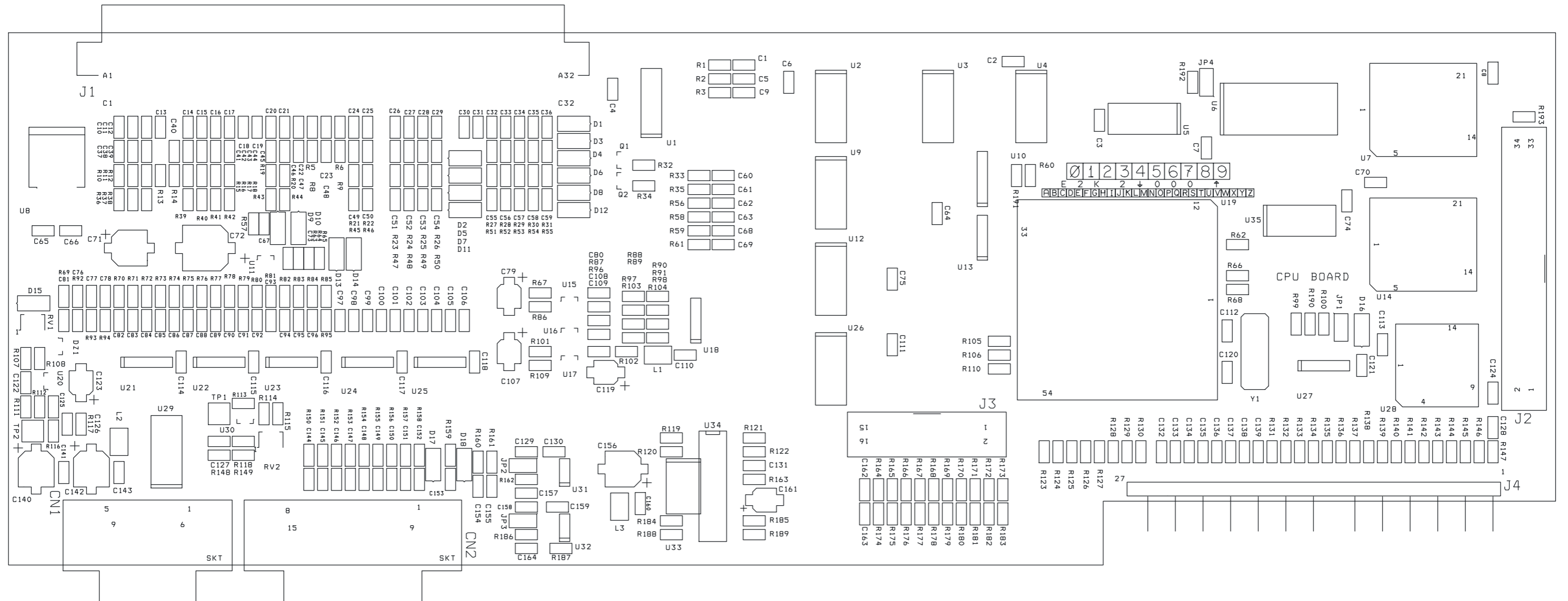

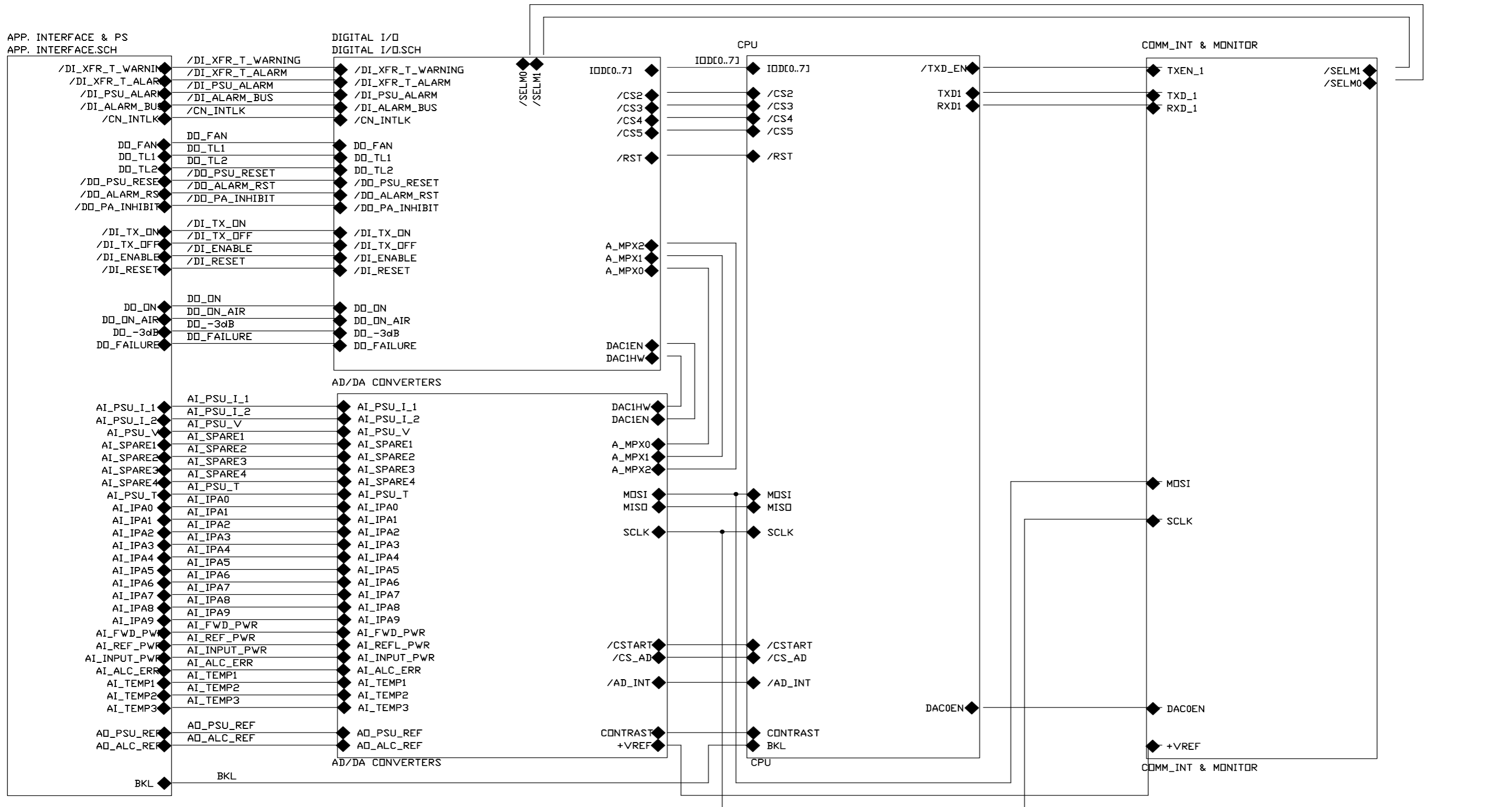

ELENOS Via G.Amendola 9 44028 Poggio Renatico (FE) Italy
Tel +39 0532 829965 Fax +39 0532 829177
Website WWW.ELENOS.COM

Title: CPU BOARD BLOCK DIAGRAM

Board Code: EPCB0258_2	Model: E5K BA021_0	Rev 2
Proj. Engr. A.Tomassini	Approved A.Giovanelli	
Date: Thursday, November 25, 2004	Sheet 1 of 6	

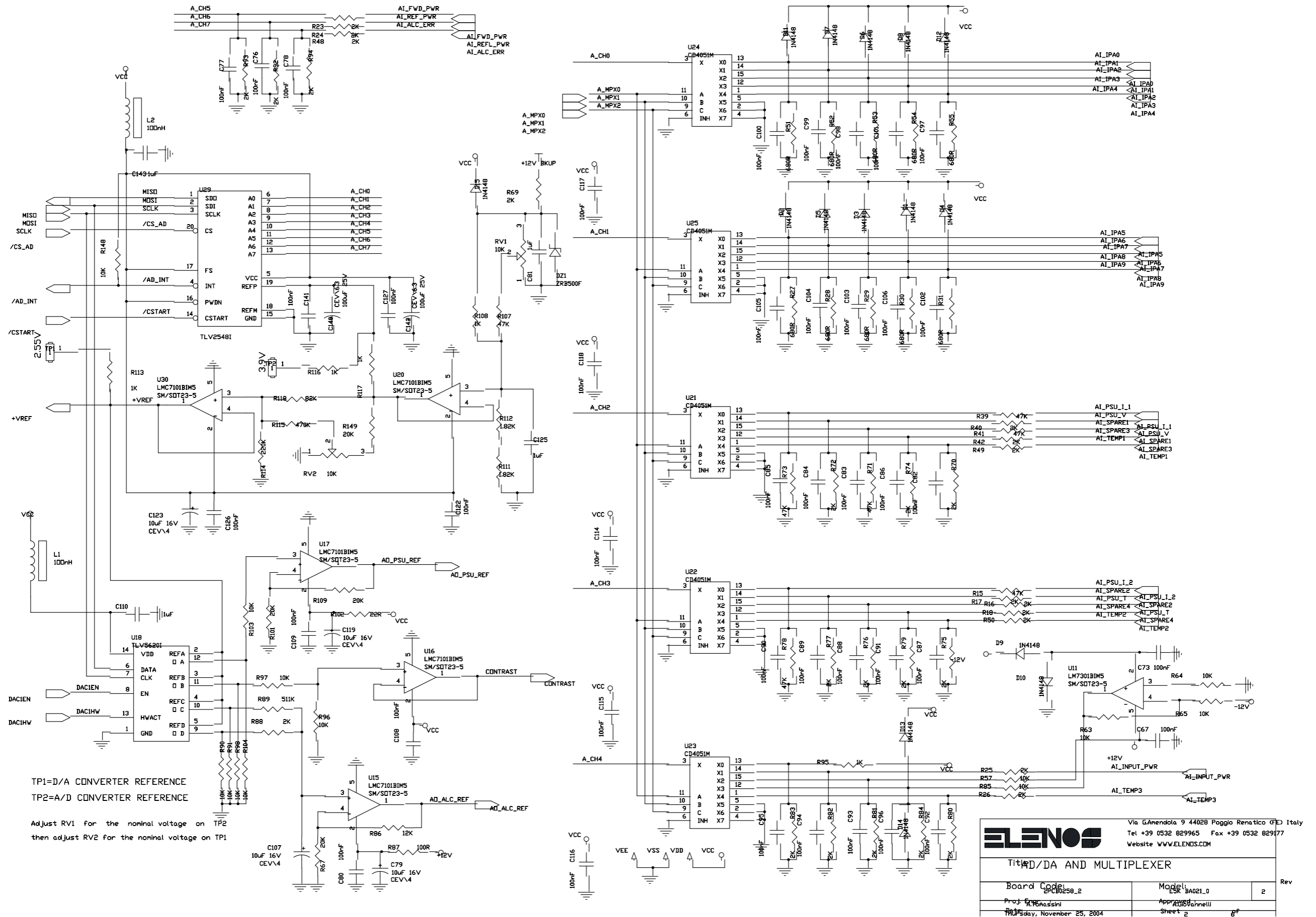

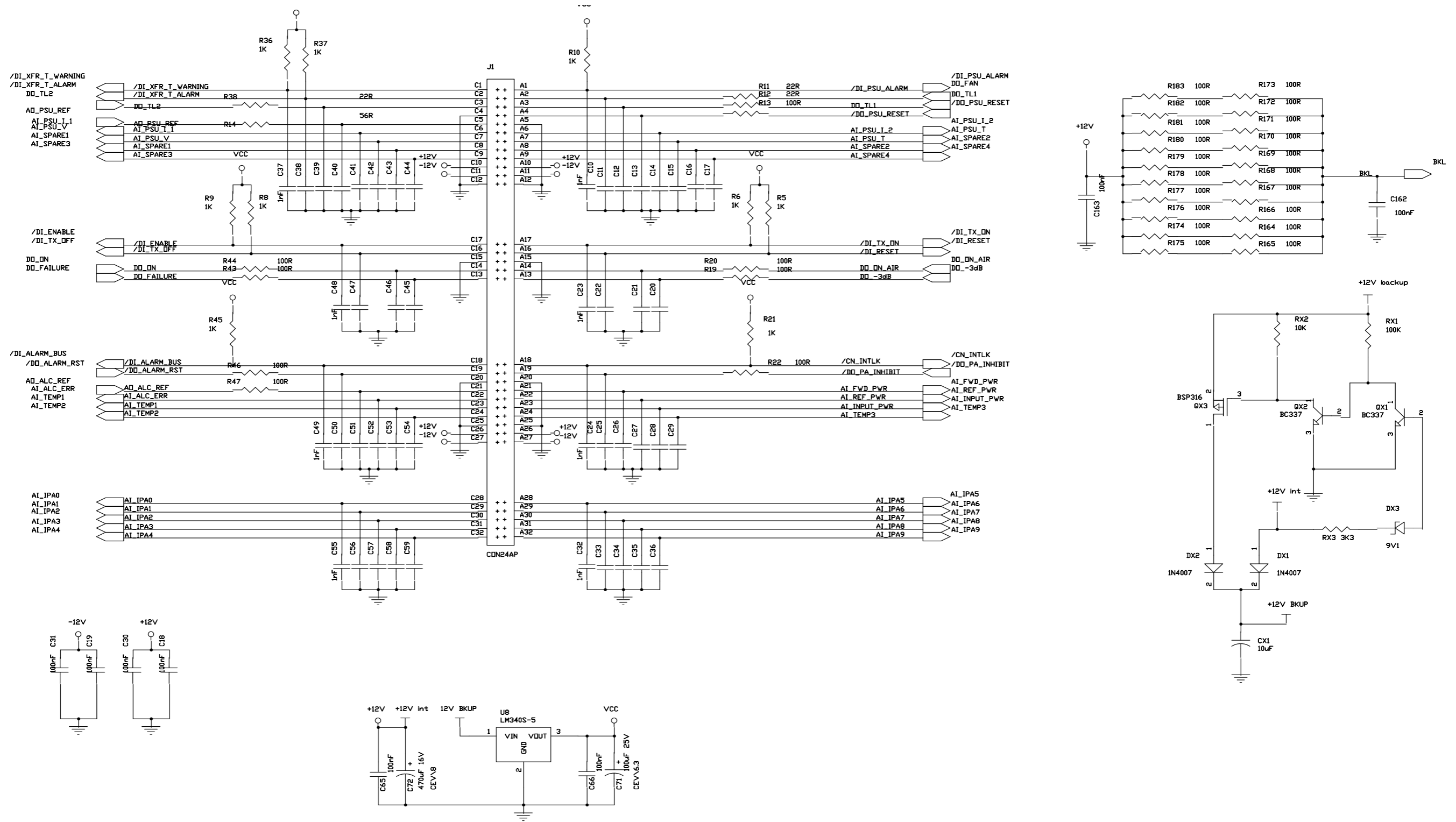

TP1=D/A CONVERTER REFERENCE
TP2=A/D CONVERTER REFERENCE
Adjust RV1 for the nominal voltage on TP2
then adjust RV2 for the nominal voltage on TP1

ELENOS		Via G.Amendola 9 44028 Poggio Renatico (FE) Italy Tel +39 0532 829965 Fax +39 0532 829177 Website WWW.ELENOS.COM	
AD/D/A AND MULTIPLEXER			
Board Code:	2PC0250_2	Model:	BA021_0
Proj.:	G. Massini	Appr.:	A. Ghinelli
Date:	Monday, November 25, 2004	Sheet:	2 of 8

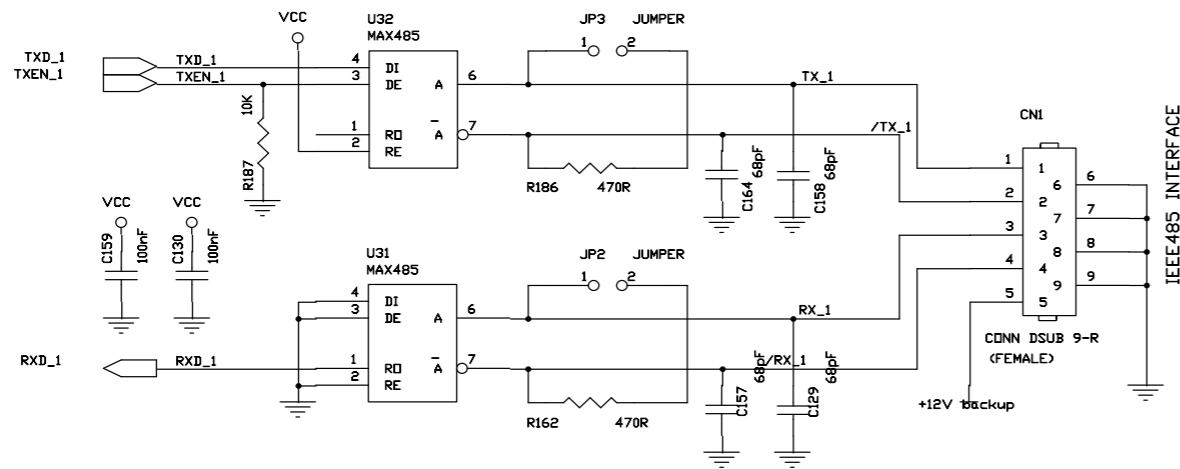
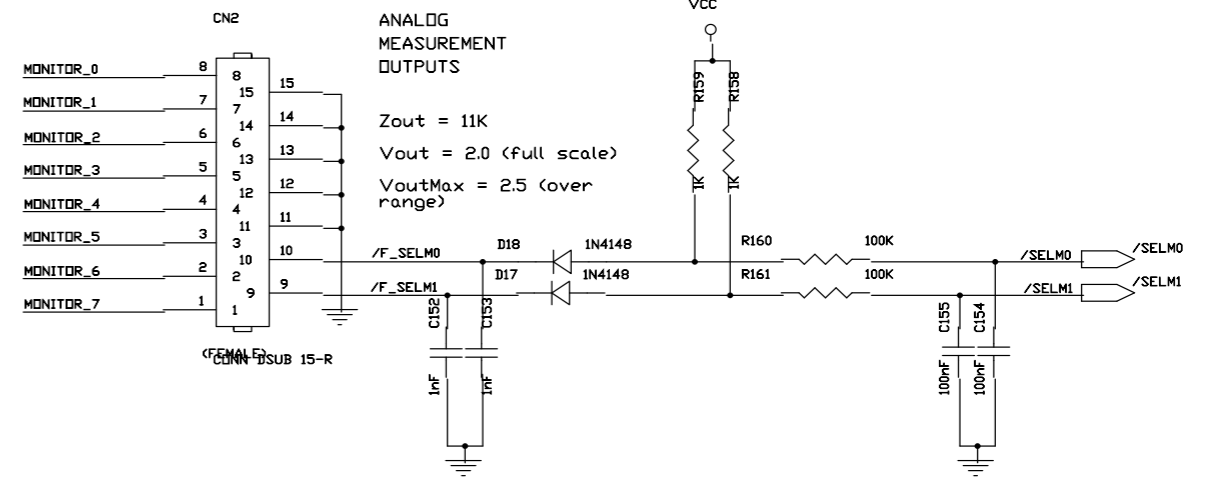
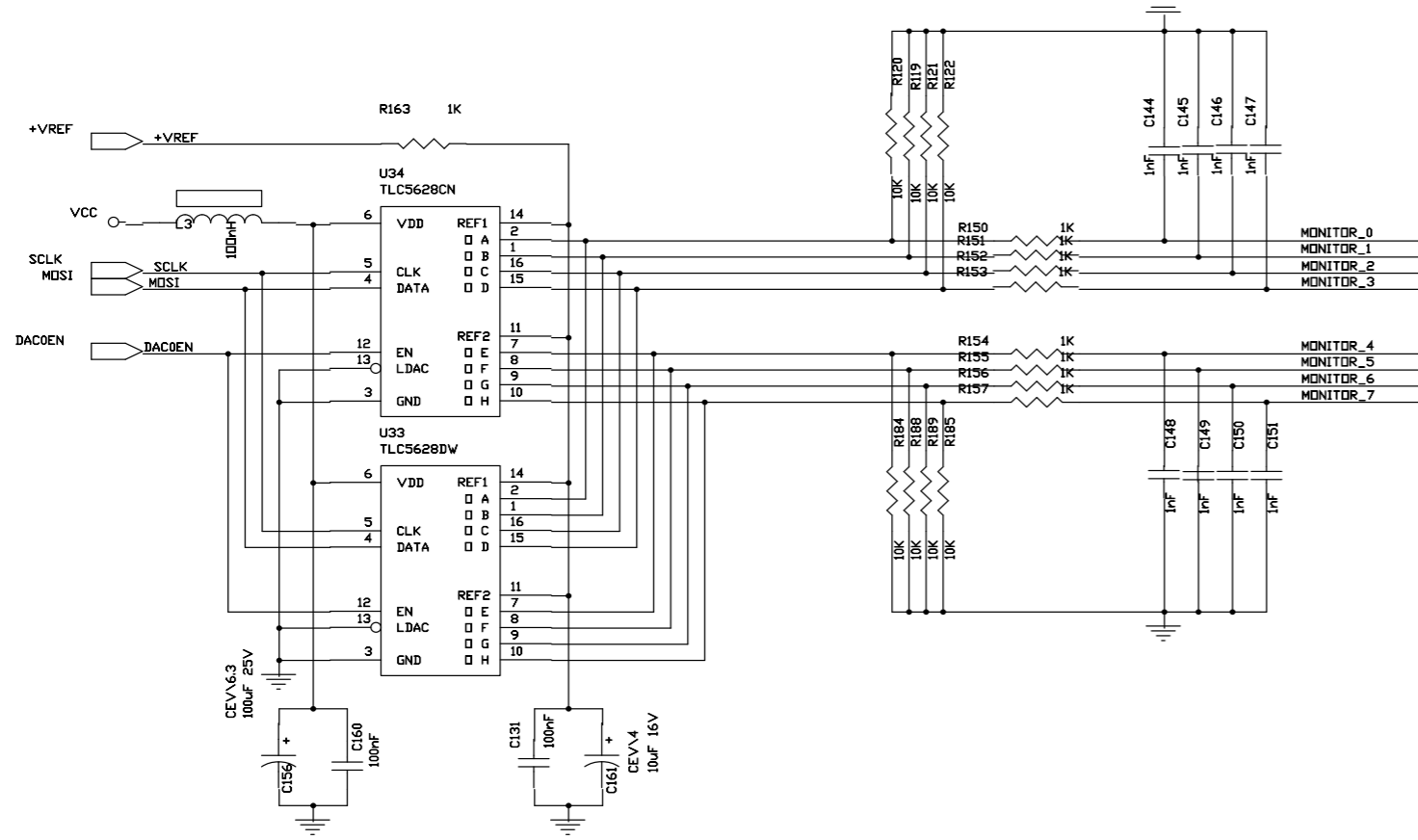

Via G.Amendola 9 44028 Poggio Renatico (FE) Italy Tel +39 0532 829965 Fax +39 0532 829177 Website WWW.ELENOS.COM		
Title: CPU BOARD CONNECTOR		
Board Code: 2PCB0258_2	Model: E5K BA021_0	Rev 2
Proj. Engr. A.Tomassini	Approved A.Giovanelli	
Date: Thursday, November 25, 2004	Sheet 3	of 6



 Via G.Amendola 9 44028 Poggio Renatico (FE) Italy Tel +39 0532 829965 Fax +39 0532 829177 Website WWW.ELENOS.COM		
Title: RS485 AND ANALOG OUTPUTS		
Board Code: EPCB0258_2	Model: ESK BA021_0	Rev 2
Proj. Engr: A.Tomassini	Approved A.Giovannelli	
Date: Thursday, November 25, 2004	Sheet 4	of 6

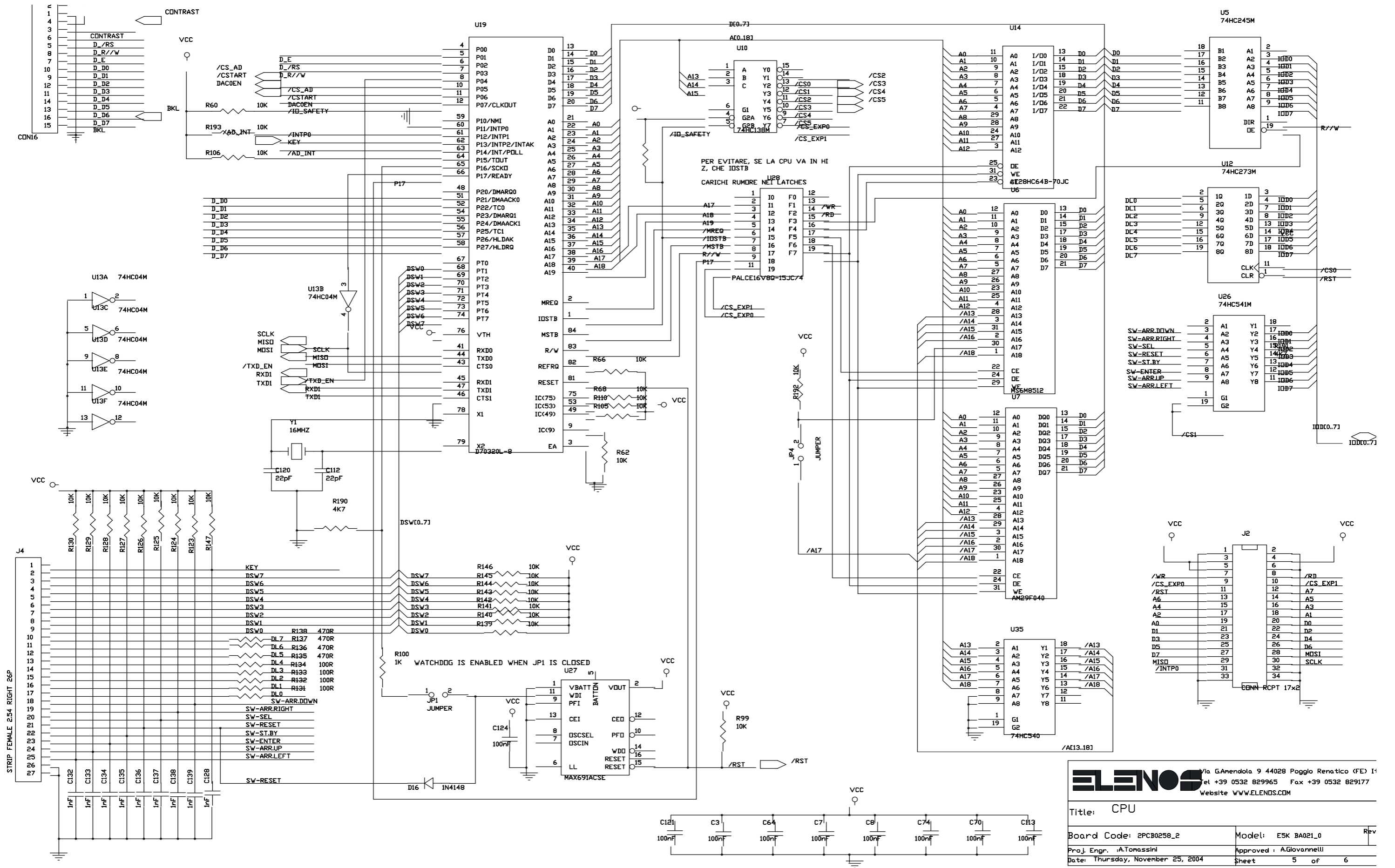

ELENOS Via G.Amendola 9 44028 Poggio Renatico (FE) I 1
Tel +39 0532 829965 Fax +39 0532 829177
Website WWW.ELENOS.COM

Title: CPU

Board Code: 2PCB0258_2	Model: ESK BA021_0	Rev
Proj. Engr. A.Tomassini	Approved: A.Giovanelli	
Date: Thursday, November 25, 2004	Sheet: 5 of 6	

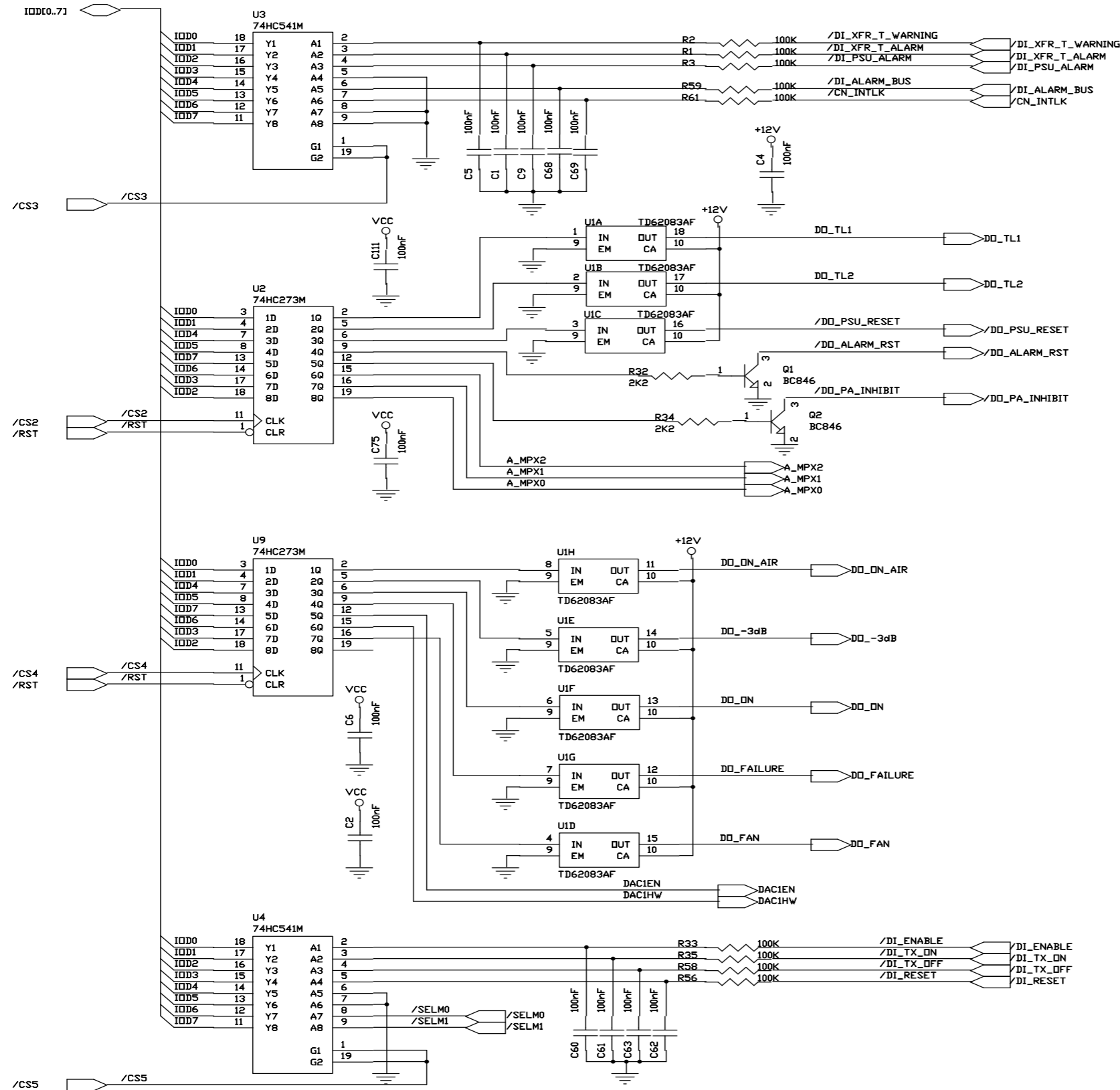

 Via G.Amendola 9 44028 Poggio Renatico (FE) Italy Tel +39 0532 829965 Fax +39 0532 829177 Website WWW.ELENOS.COM		
		Title: DIGITAL I/O
Board Code: pCB0258_2	Model: ESK BA021_0	Rev: 2
Proj. Engr. A.Tomassini	Approved A.Giovannelli	
Date: Thursday, November 25, 2004	Sheet: 6	of: 6

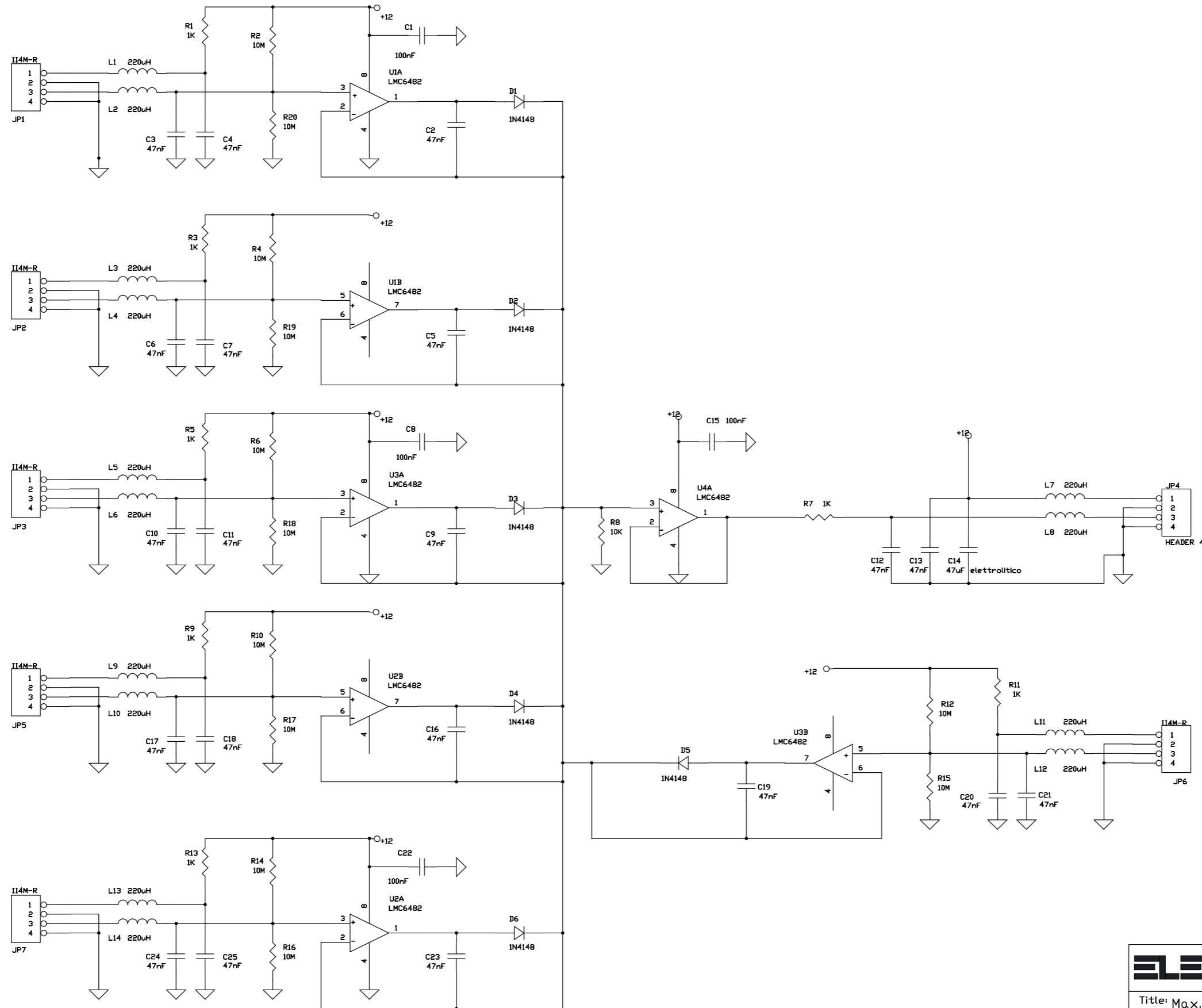

		Via G.Amendola 9 44028 Poggio Renatico (FE) Italy	
		Tel +39 0532 829965 Fax +39 0532 829177 Website WWW.ELENOS.COM	
Title: Max.temp.detector			
Board Code: 2PC80305_0	Model: ESK 7A021_0	Rev	0
Proj. Eng. G.Michelini	Approved A.Giovanelli		
Date: Monday, December 13, 2004	Sheet	1	of 2

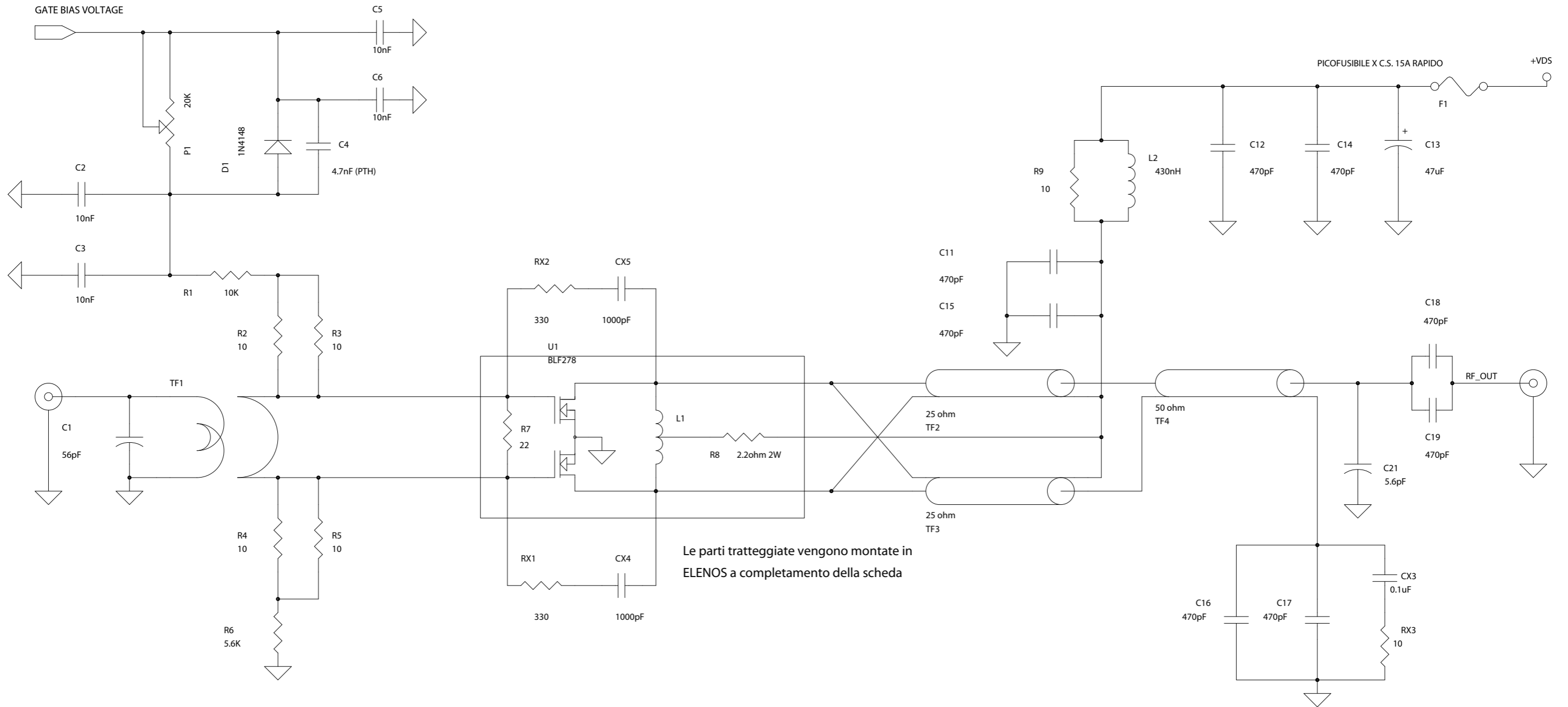

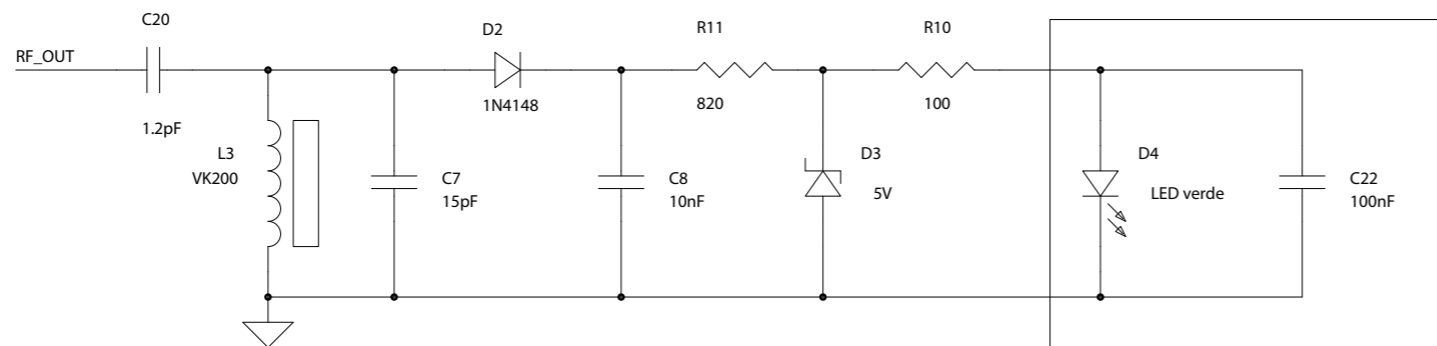

Le parti tratteggiate vengono montate in ELENOS a completamento della scheda

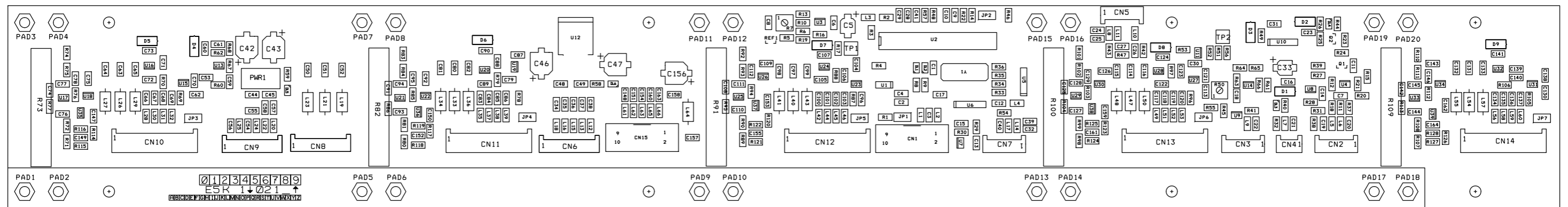

		Via G. Amendola 9 44028 Poggio Renatico (FE) Italy Tel. +39 0532 829965 Fax +39 0532 82917 Website WWW.ELENOS.COM			
		Description : RF POWER AMPLIFIER			
SCH Code :	E5K 0A(B)021_0	PCB Code :	2PCB0370_1 2PCB0253_2	Model :	E5000
Proj. Eng.	A.Tomassini	Approved :	A.Giovannelli		
Date :	26/05/03	Sheet :	1	of	1

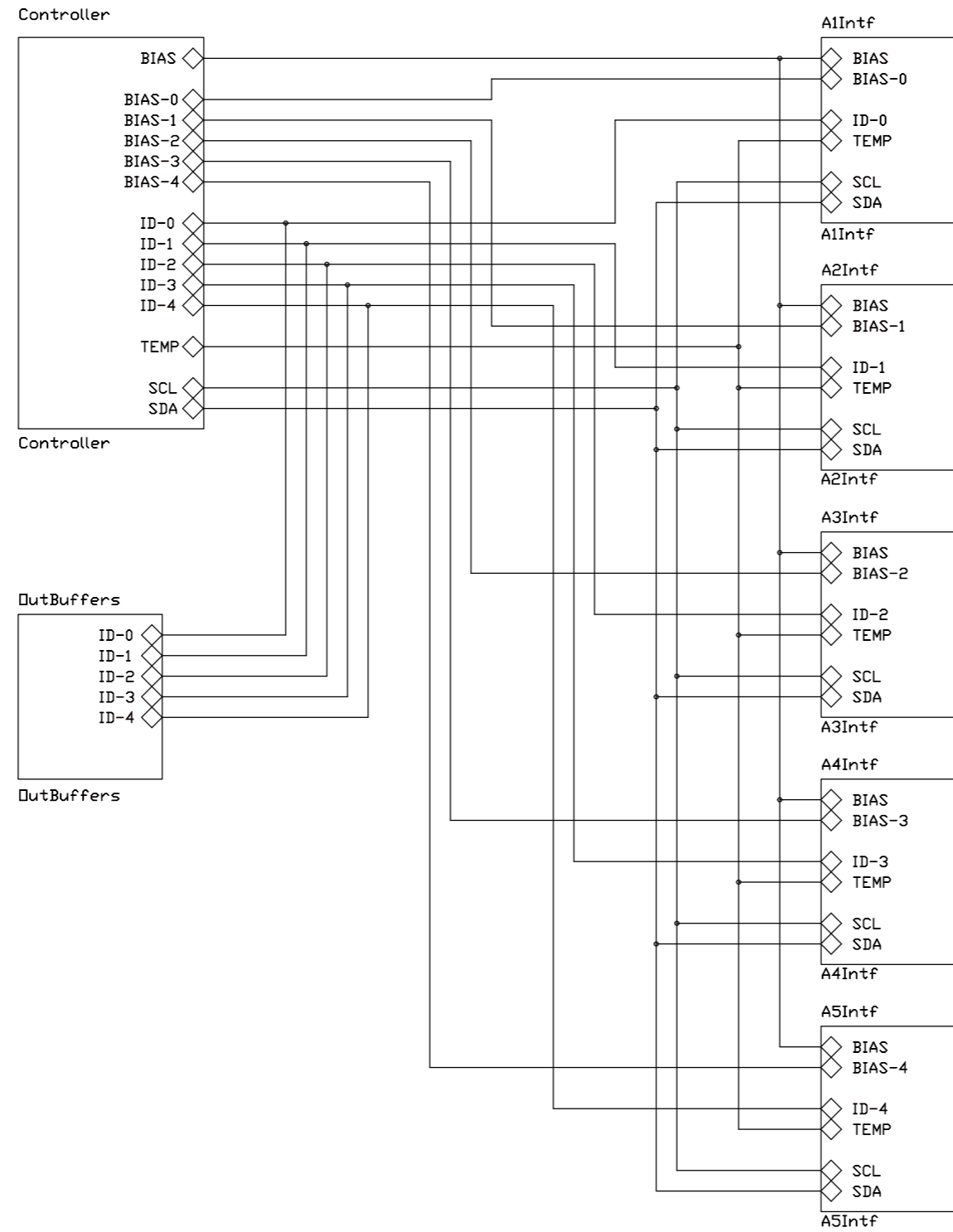



 Via G.Amendola 9 44028 Poggio Renatico (FE) Italy Tel +39 0532 829965 Fax +39 0532 829177 Website WWW.ELENOS.COM		
Title: SCHEDA SHUNT		
Board Code: 2PCB0373_0	Model: E5K 1A021_0	Rev 1
Proj. Engr. : Vallini	Approved : A.Giovannelli	
Date: Monday, December 13, 2004	Sheet	1 of 8

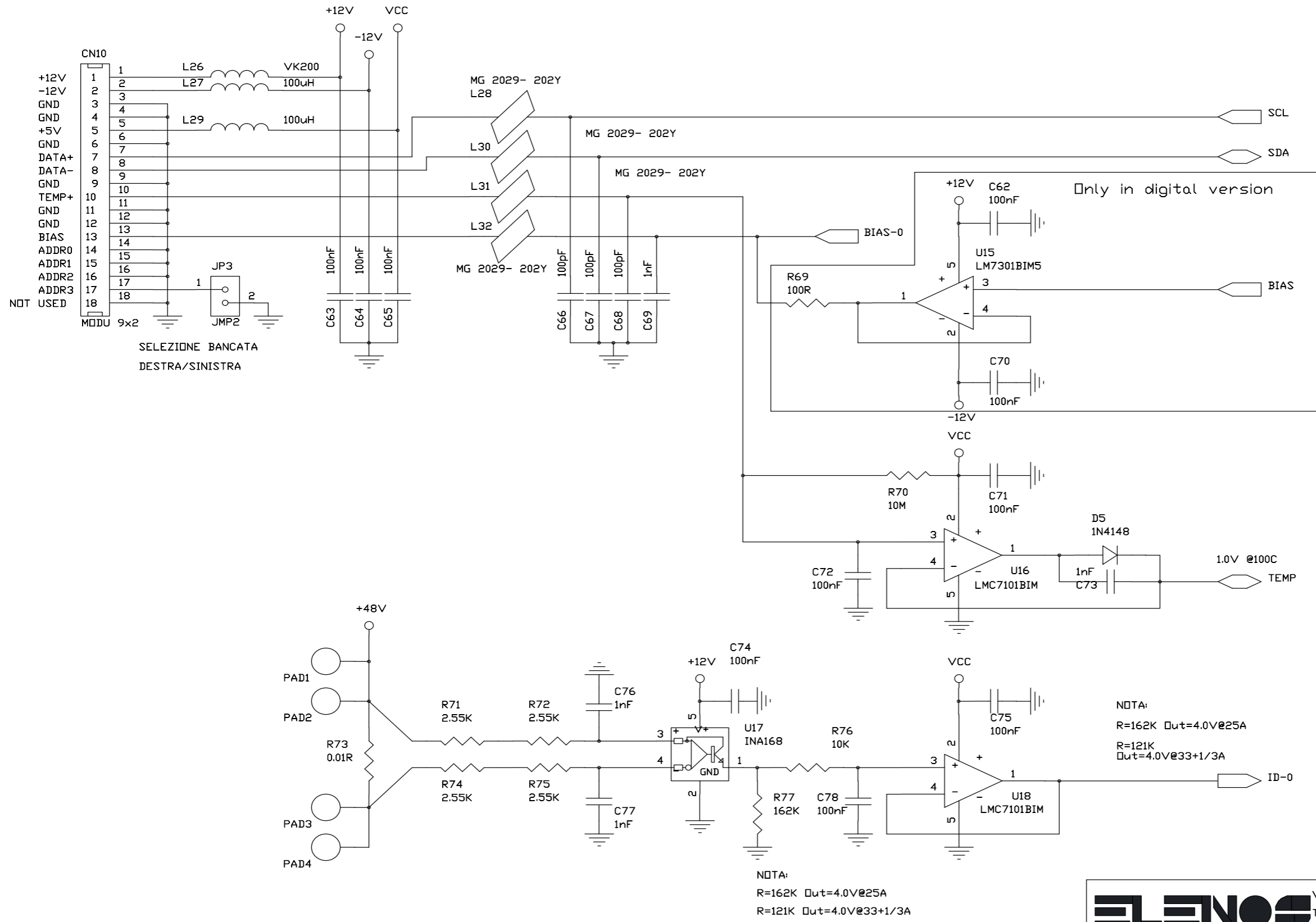

ELENOS Via G.Amendola 9 44028 Poggio Renatico (FE) Italy
Tel +39 0532 829965 Fax +39 0532 829177
Website WWW.ELENOS.COM

Title: AMPLIFIER 1 INTERFACE		
Board Code: 2PCB0373_0	Model: E5K 1A021_0	Rev 1
Proj. Engr. : Vallini	Approved : A.Giovanelli	
Date: Monday, December 13, 2004	Sheet 2 of 8	

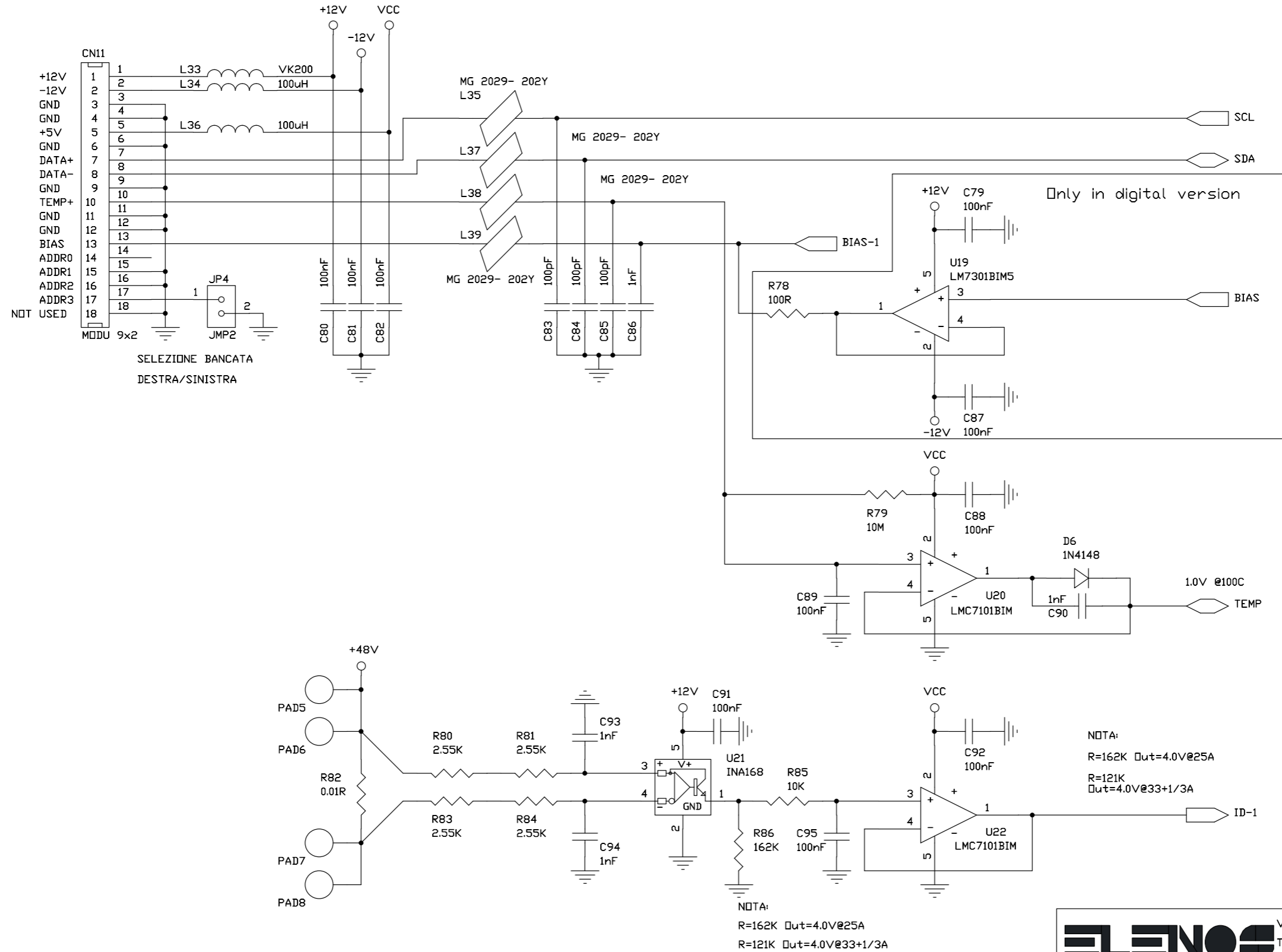

ELENOS Via G.Amendola 9 44028 Poggio Renatico (FE) Italy
Tel +39 0532 829965 Fax +39 0532 829177
Website WWW.ELENOS.COM

Title: Amplifier 2 interface		
Board Code: 2PCB0373_0	Model: E5K 1A021_0	Rev 1
Proj. Engr. : Vallini	Approved : A.Giovanelli	
Date: Monday, December 13, 2004	Sheet 3	of 8

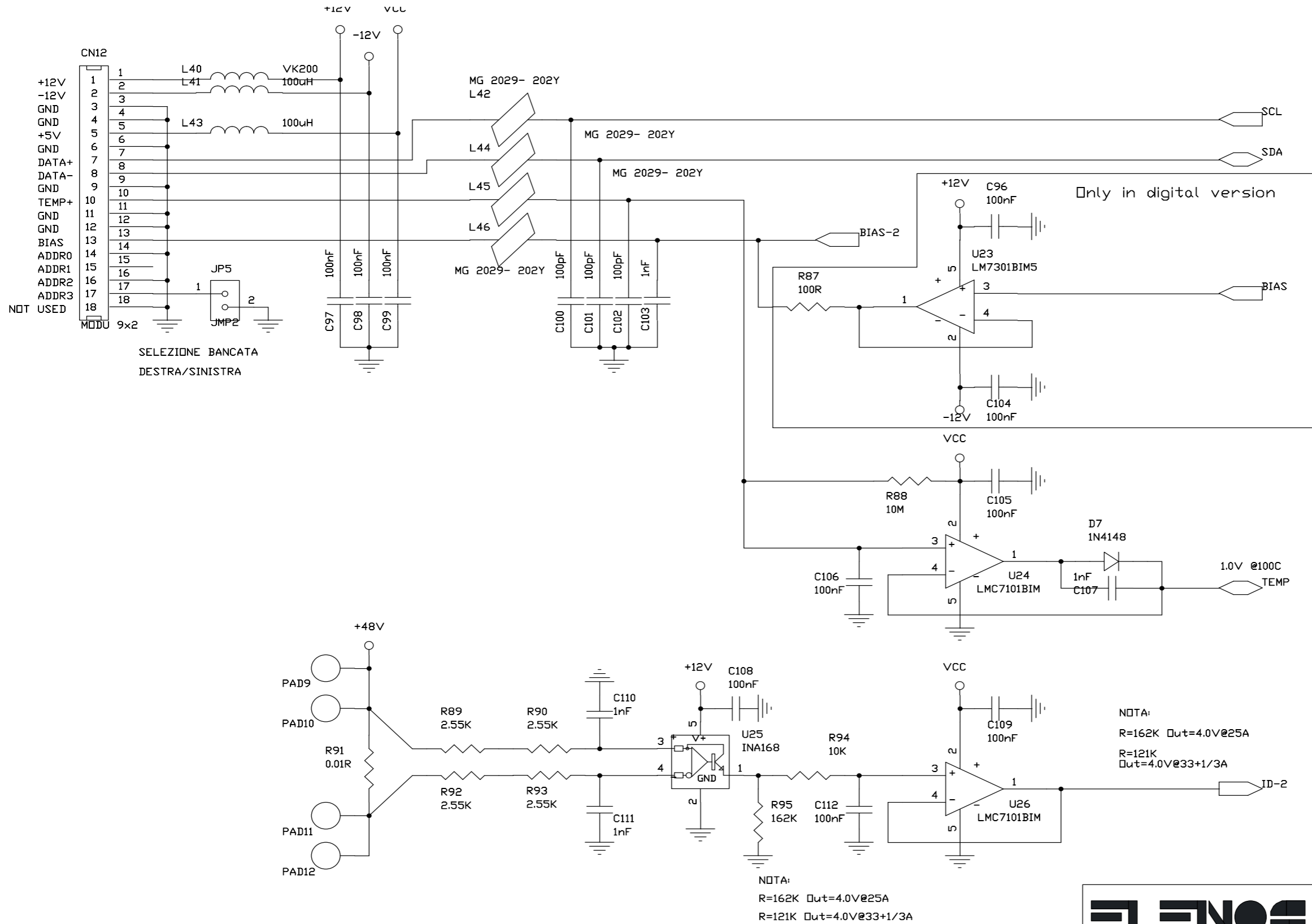

NOTA:
R=162K Out=4.0V@25A
R=121K Out=4.0V@33+1/3A

NOTA:
R=162K Out=4.0V@25A
R=121K Out=4.0V@33+1/3A



Via G.Amendola 9 44028 Poggio Renatico (FE) Italy
Tel +39 0532 829965 Fax +39 0532 829177
Website WWW.ELENOS.COM

Title: Amplifier 3 interface

Board Code: P2PCB0373_0	Model: E5K 1A021_0	Rev 1
Proj. Engr. : Vallini	Approved : A.Giovanelli	
Date: Monday, December 13, 2004	Sheet 4	of 8

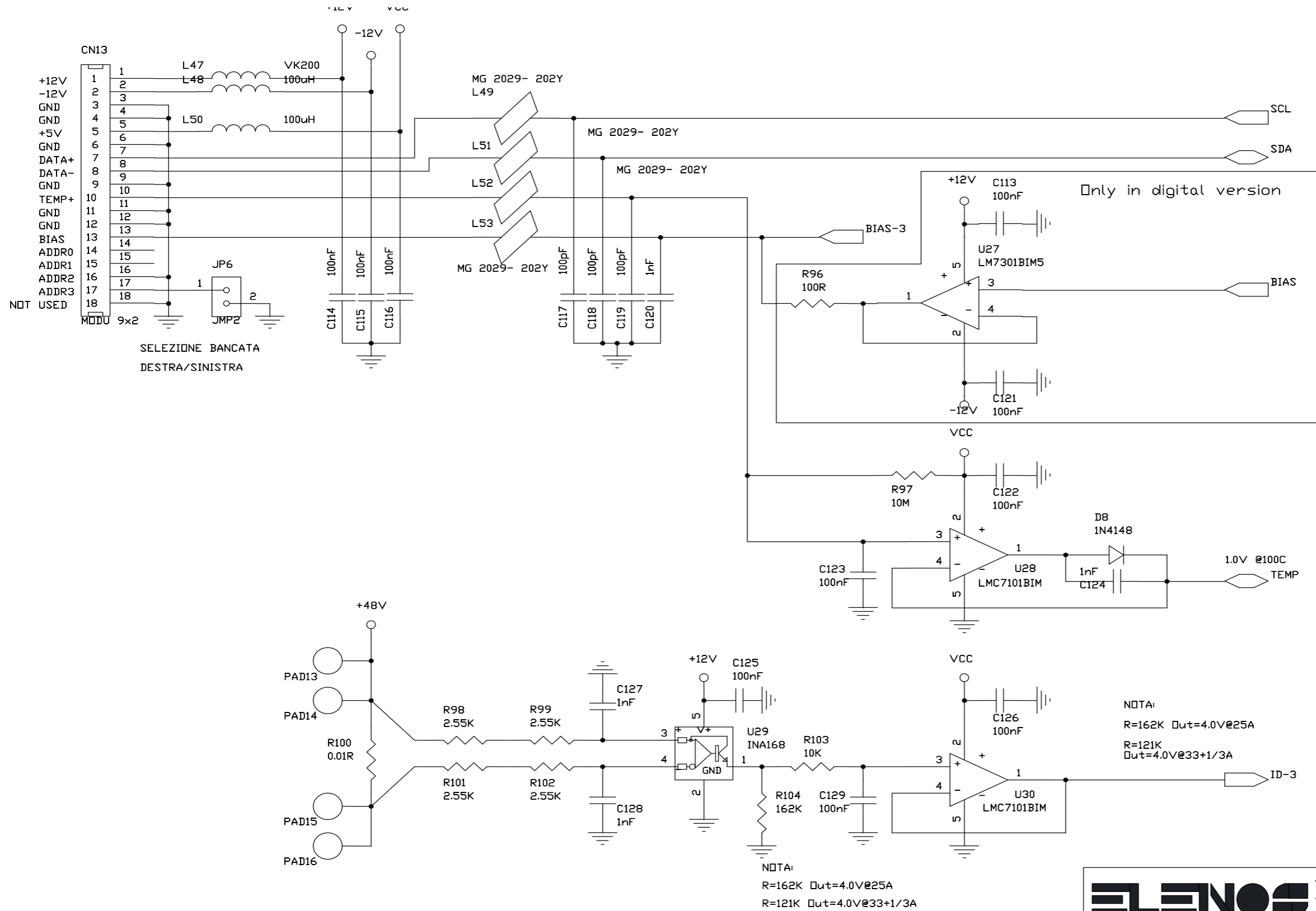

ELENOS Via G.Amendola 9 44028 Poggio Renatico (FE) Italy
Tel +39 0532 829965 Fax +39 0532 829177
Website WWW.ELENOS.COM

Title: Amplifier 4 interface		
Board Code: 2PCB0373_0	Model: E5K 1A021_0	Rev 1
Proj. Engr. Vallini	Approved: A.Giovannelli	
Date: Monday, December 13, 2004	Sheet 5 of 8	

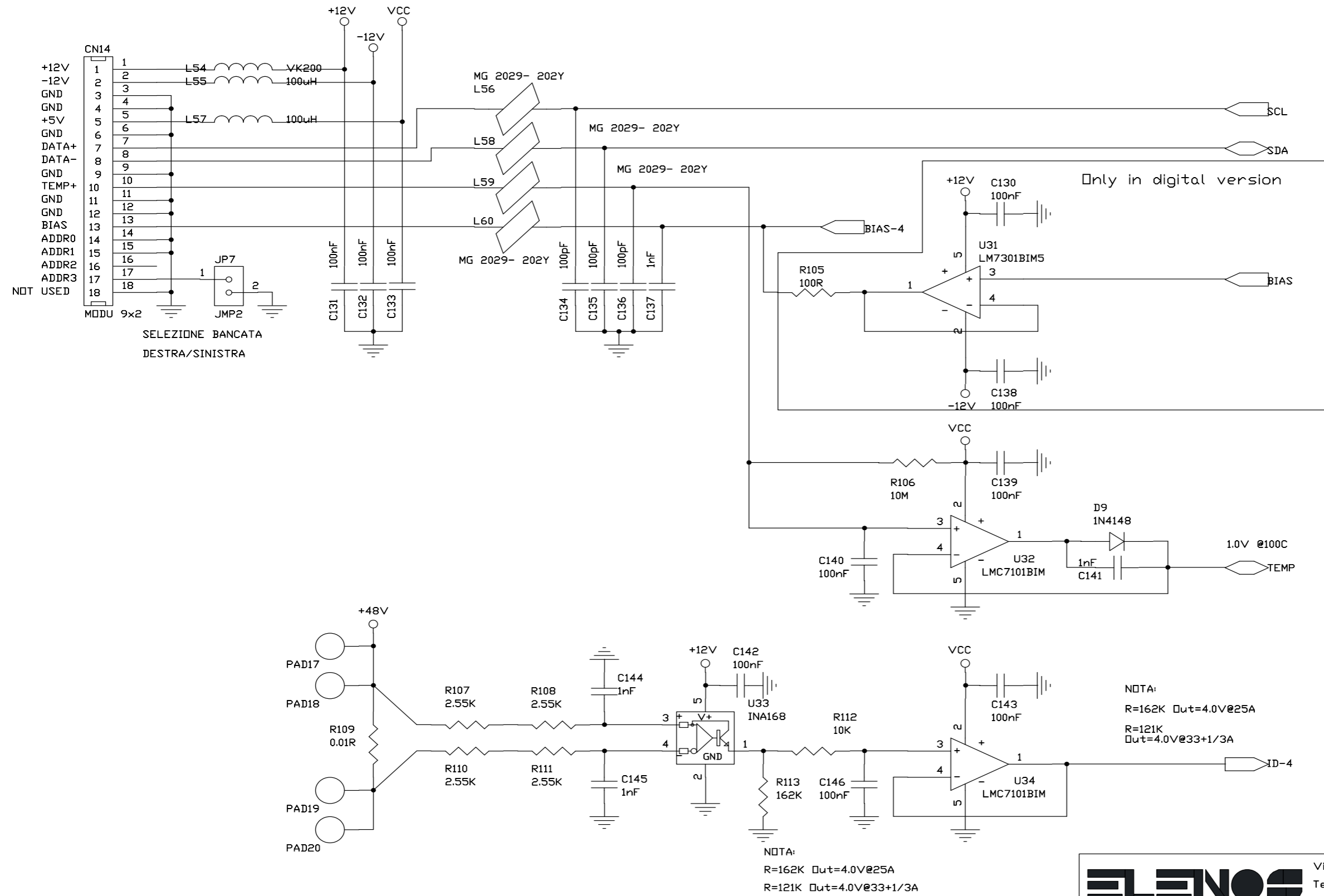

NOTA:
R=162K Out=4.0V@25A
R=121K Out=4.0V@33+1/3A

 Via G.Amendola 9 44028 Poggio Renatico (FE) Italy Tel +39 0532 829965 Fax +39 0532 829177 Website WWW.ELENOS.COM		
		Title: Amplifier 5 interface
Board Code: PFCB0373_0	Model: E5K 1A021_0	Rev 1
Proj. Engr. Vallini	Approved: A.Giovannelli	
Date: Monday, December 13, 2004	Sheet 6 of 8	

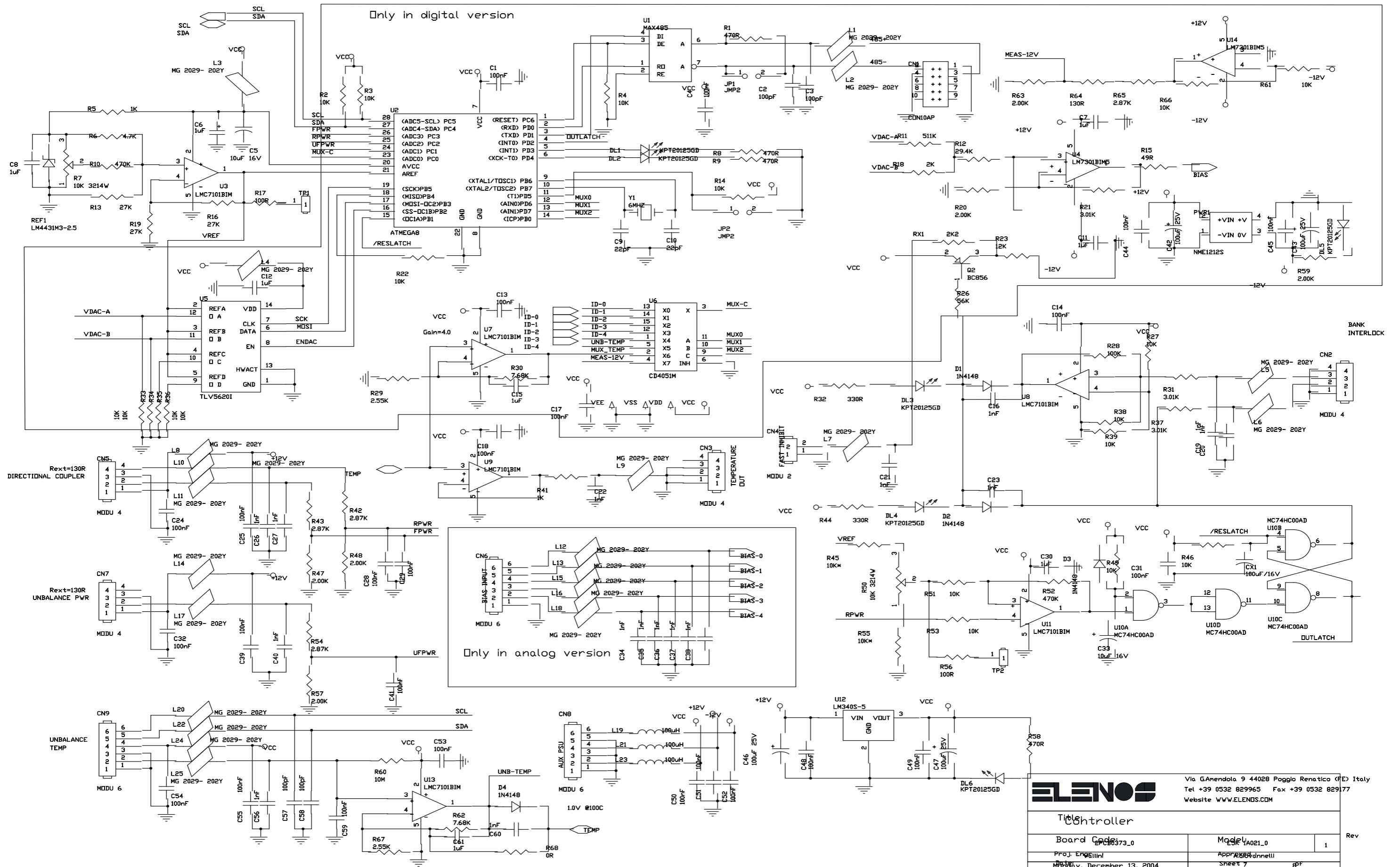

ELENOS		Via G.Amendola 9 44028 Poggio Renatico (FE) Italy Tel +39 0532 829965 Fax +39 0532 829177 Website WWW.ELENOS.COM	
Title Controller		Rev	
Board Code PCB373_0	Model LA021_0	1	
Proj Engineer M. B. ...	Appr. ...	sheet 7 of 8	
Date December 13, 2004			

Only in analog version

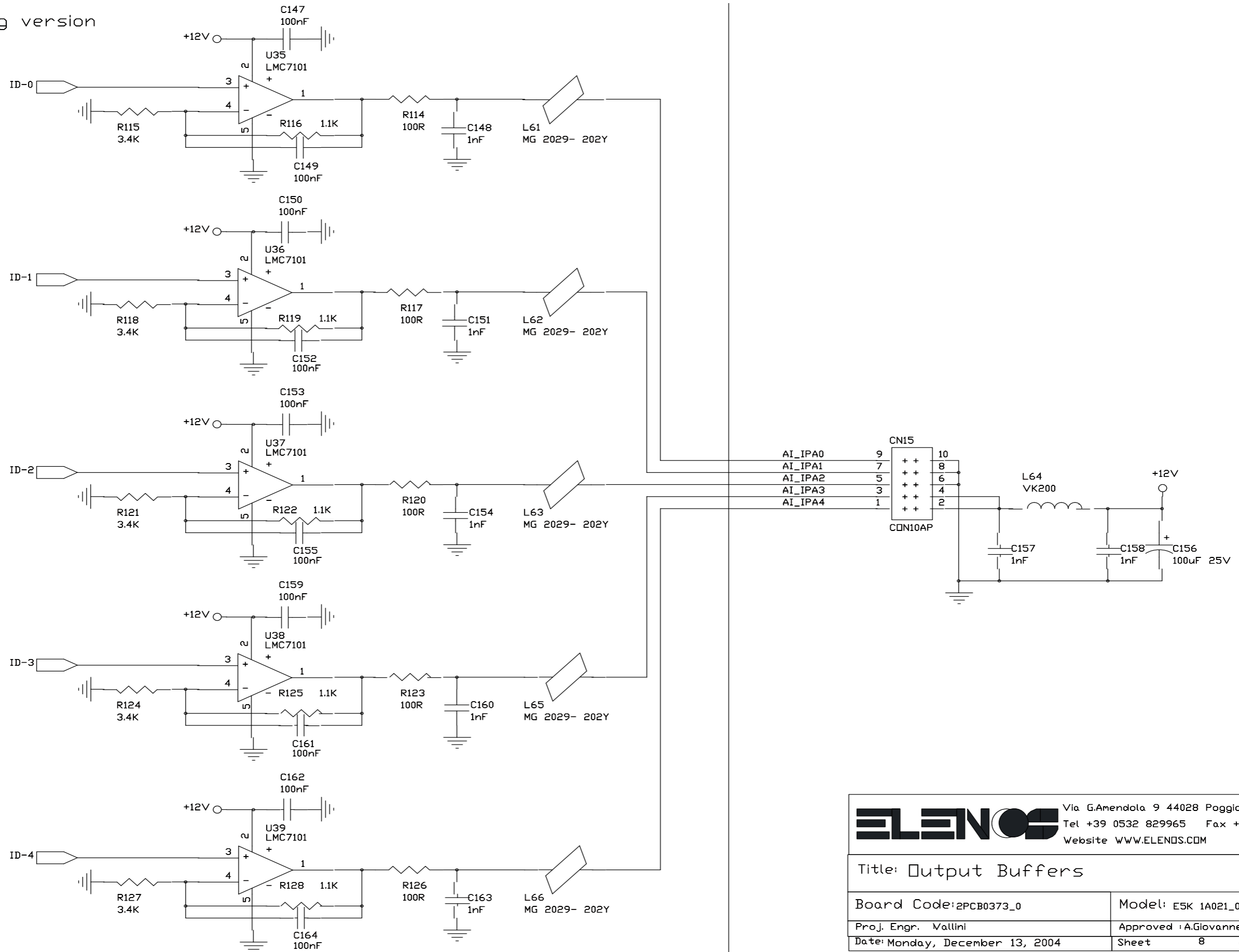

			Via G.Amendola 9 44028 Poggio Renatico (FE) Italy Tel +39 0532 829965 Fax +39 0532 829177 Website WWW.ELENOS.COM		
Title: Output Buffers					
Board Code: 2PCB0373_0		Model: ESK 1A021_0		Rev 1	
Proj. Engr. Vallini			Approved: A.Giovanelli		
Date: Monday, December 13, 2004			Sheet 8 of 8		

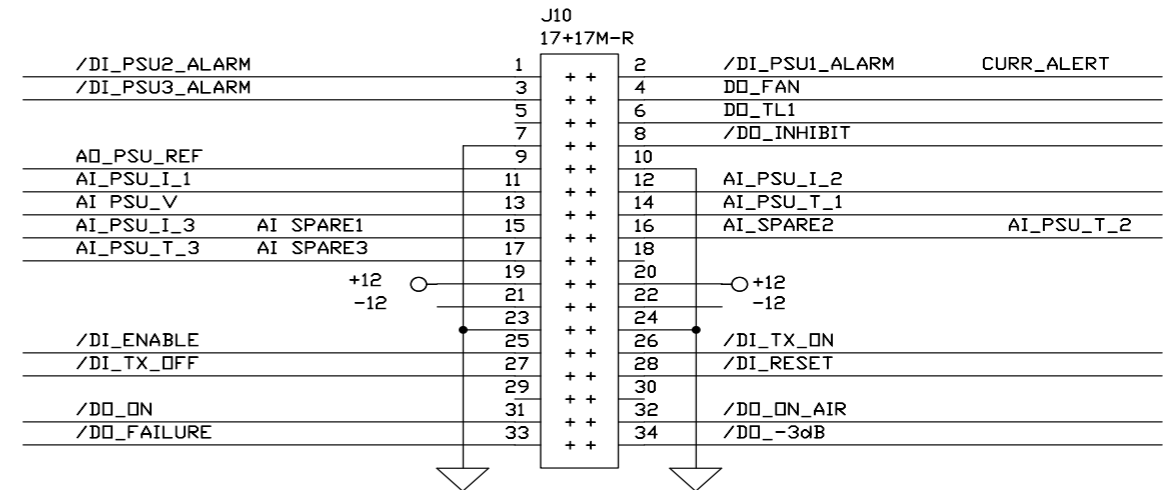
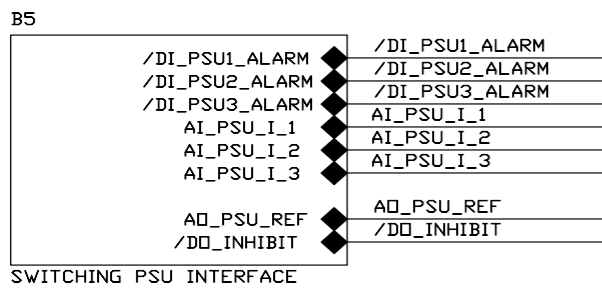
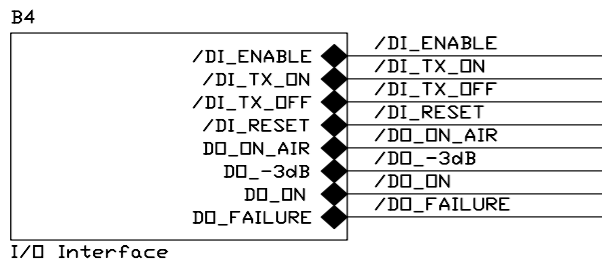
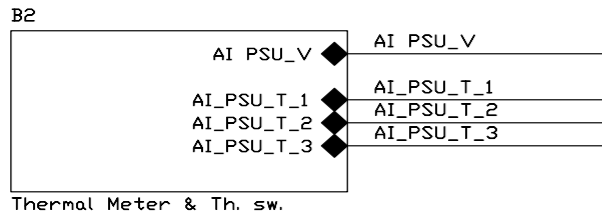
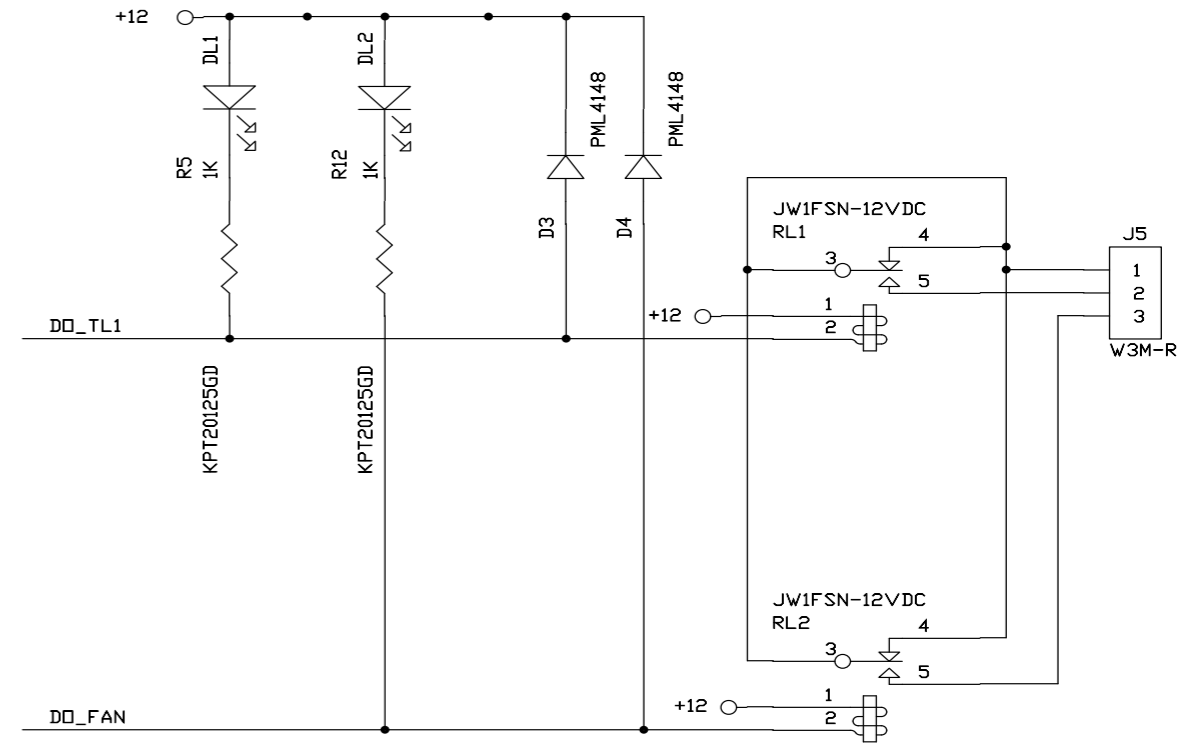
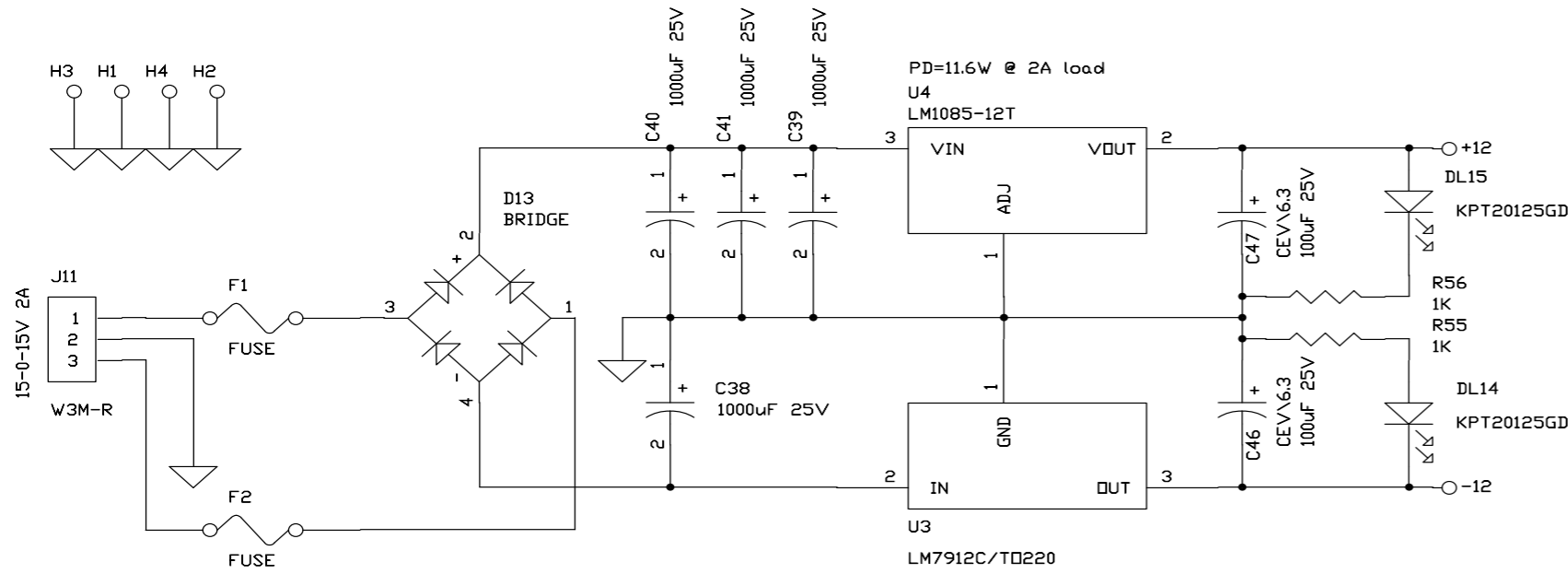

ELENOS Via G.Amendola 9 44028 Poggio Renatico (FE) Italy
Tel +39 0532 829965 Fax +39 0532 829177
Website WWW.ELENOS.COM

Title: SERVICE POWER SUPPLY		
Board Code: 2PCB0272_2	Model: E2K AA000_1	Rev 2
Proj. Engr. A.Tomassini	Approved: A.Giovanelli	
Date: Thursday, April 03, 2003	Sheet 1 of 4	

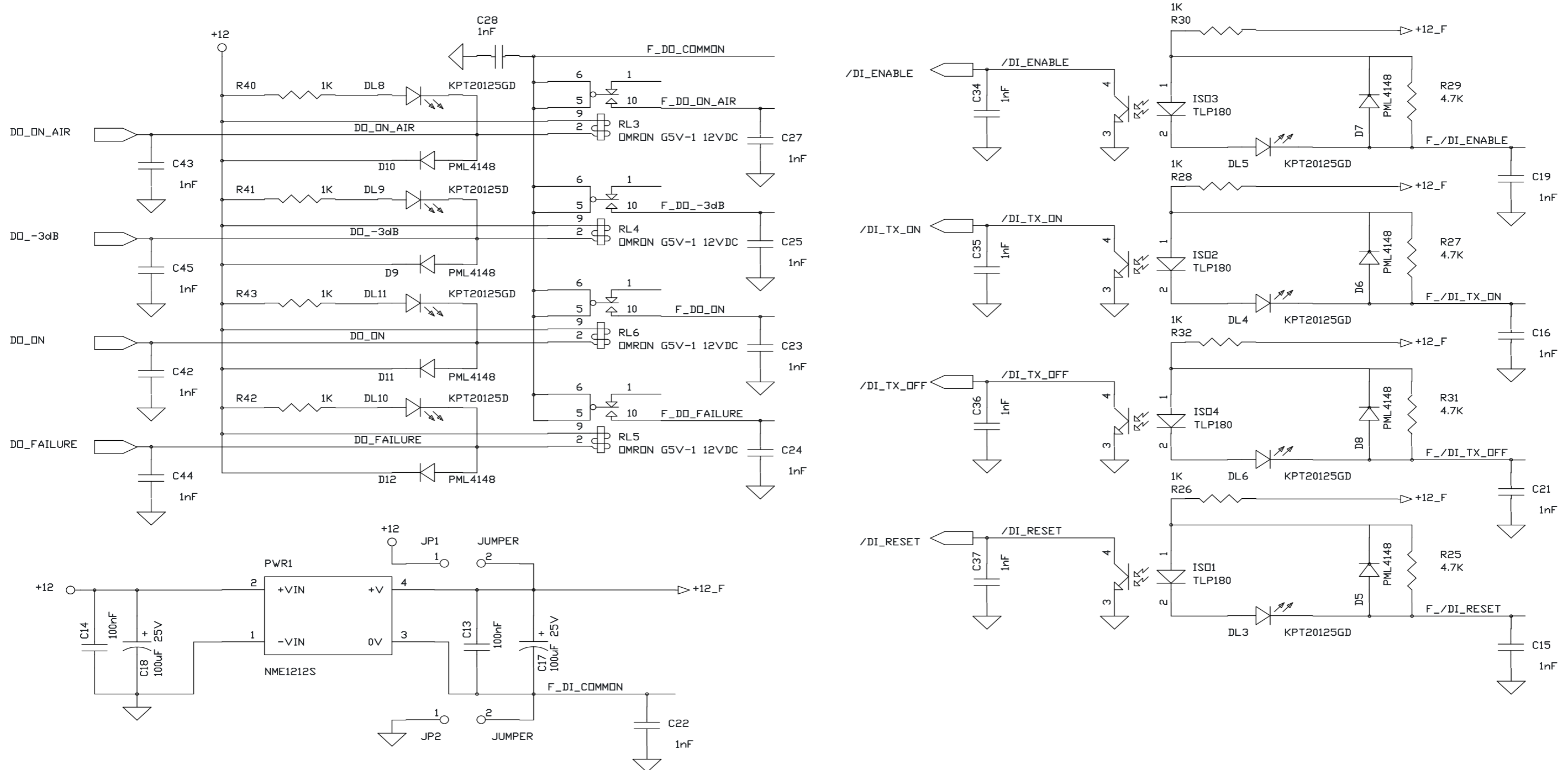

J9

F_/DI_ENABLE	9	++	10	F_/DI_TX_ON
F_/DI_TX_OFF	7	++	8	F_/DI_RESET
F_DI_COMMON	5	++	6	F_DO_COMMON
F_DO_ON	3	++	4	F_DO_ON_AIR
F_DO_FAILURE	1	++	2	F_DO_-3dB

5+5M-R

 Via G.Amendola 9 44028 Poggio Renatico (FE) Italy Tel +39 0532 829965 Fax +39 0532 829177 Website WWW.ELENOS.COM		
Title: I/O USER INTERFACE		
Board Code: 2PCB0272_2	Model: E2K AA000_1	Rev 2
Proj. Engr. A.Tomassini	Approved: A.Gioannelli	
Date: Thursday, April 03, 2003	Sheet 2 of 4	

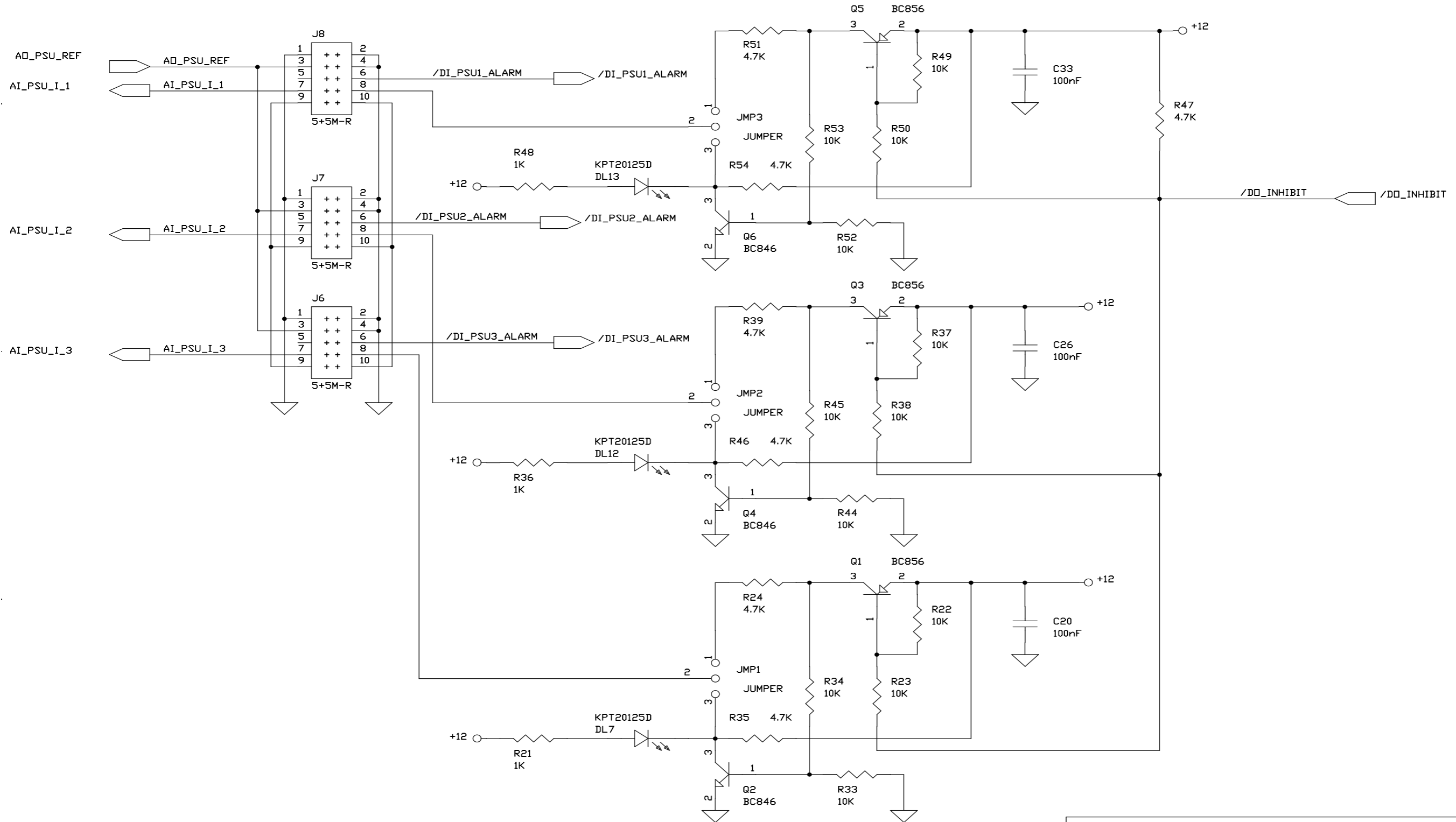

 Via G.Amendola 9 44028 Poggio Renatico (FE) Italy Tel +39 0532 829965 Fax +39 0532 829177 Website WWW.ELENOS.COM			
		Title: PSU INTERFACE	
Board Code: zPCB0272_2	Model: E2K AA000_1	Rev 2	
Proj. Engr. A.Tomassini	Approved : A.Gioannelli		
Date: Thursday, April 03, 2003	Sheet	3	of 4

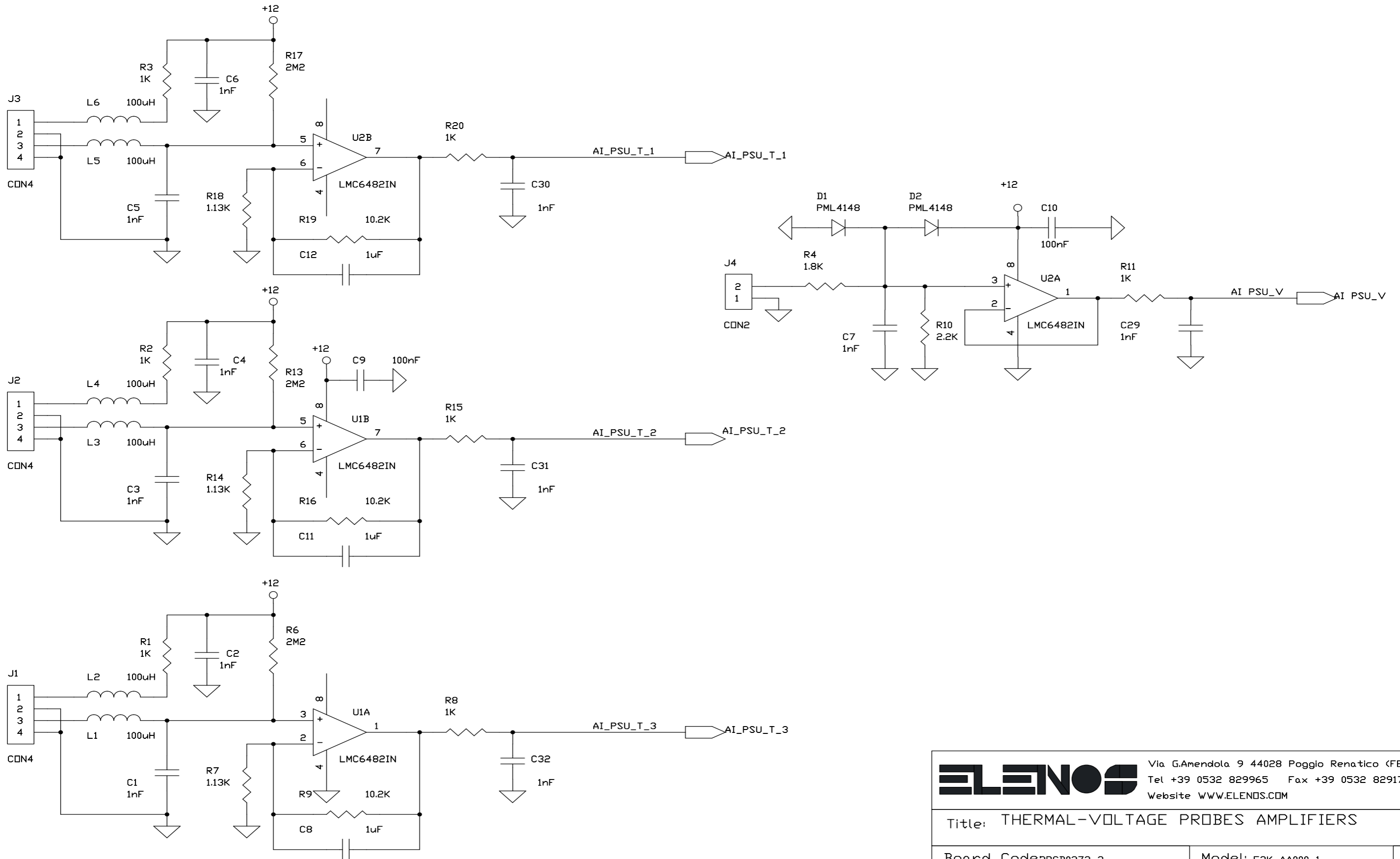

 Via G.Amendola 9 44028 Poggio Renatico (FE) Italy Tel +39 0532 829965 Fax +39 0532 829177 Website WWW.ELENOS.COM		
Board Code: 2PCB0272_2	Model: E2K AA000_1	Rev 2
Proj. Engr. A.Tomassini	Approved A.Giovannelli	
Date: Thursday, April 03, 2003	Sheet 4	of 4

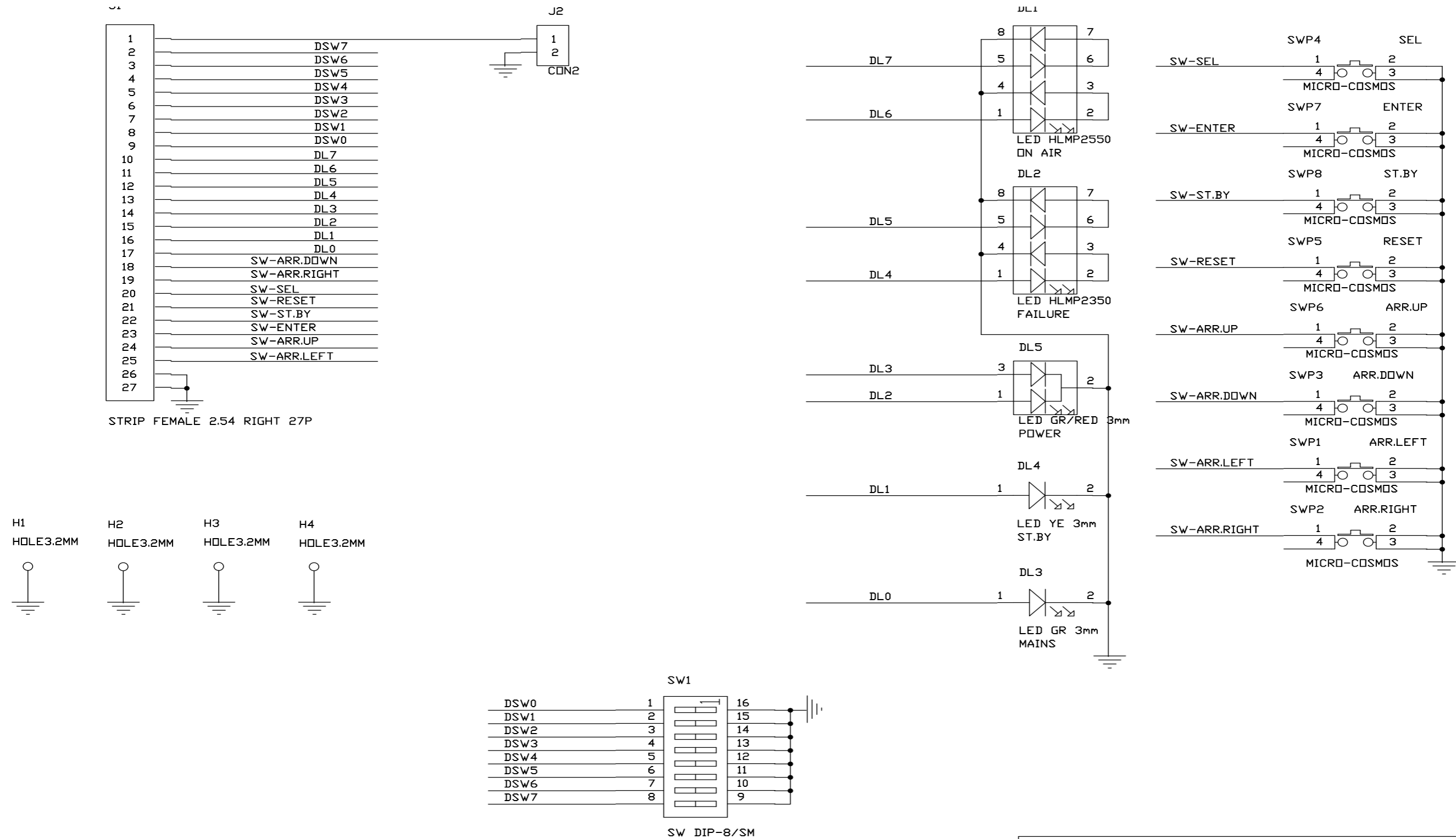

ELENOS Via G.Amendola 9 44028 Poggio Renatico (FE) Italy
Tel +39 0532 829965 Fax +39 0532 829177
Website WWW.ELENOS.COM

Title: KEYBOARD		
Board Code: 2PCB0270_1	Model: E2K 8A000_1	Rev 1
Proj. Engr. A.Tomassini	Approved: A.Giovannelli	
Date: Friday, June 15, 2001	Sheet 1 of 1	

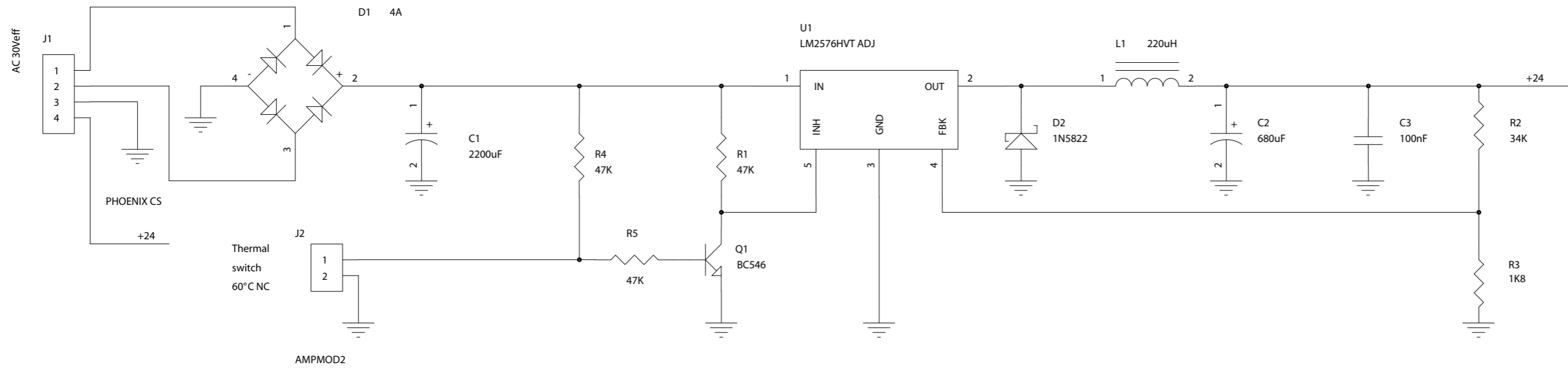

		Via G.Amendola 9 44028 Poggio Renatico (FE) Italy	
		Tel +39 0532 829965 Fax +39 0532 829177 Website WWW.ELENOS.COM	
Title: ALIMENTATORE VENTILATORI			
SCH Code:	C4K 5A011_1	PCB Code:	2PCB0321_1
Model:	CB4000		
Proj. Eng. :	A.Tomassini	Approved :	A.Gioannelli
Date:	Friday, April 15, 2005	Sheet	1 of 1

