

ETG150

ETG150/S



ELENOS

BROADCAST EQUIPMENT

Via G. Amendola 9
44028 Poggio Renatico
Ferrara - Italy

Tel : +39 532 829 965

Fax : +39 532 829 177

E-mail: info@elenos.com

support@elenos.com

Web Site: <http://www.elenos.com>

The constructor reserves the right to modify the information in this manual at any time without advising update.

**2000 Elenos S.r.l.
Printed in Italy
Cod. MAN0039**

<p>26/05/2000 Preliminary mater in English 09/06/2000 Rev. 1</p>

1 – CONTENTS

1 – CONTENTS.....	3
2 – INTRODUCTION.....	7
3 – SAFETY.....	9
4 – PRECAUTIONS.....	11
5 – FIRST AID.....	13
TREATMENT OF ELECTRICAL BURNS.....	13
TREATMENT OF ELECTRIC SHOCKS.....	14
6 – INSTALLATION.....	15
INTRODUCTION.....	15
UNPACKING.....	15
INSTALLATION.....	15
7 – FRONT VIEW.....	17
FRONT PANEL DESCRIPTION.....	17
8 – REAR VIEW.....	19
REAR PANEL DESCRIPTION.....	19
9 – GENERAL DESCRIPTION.....	21
INTRODUCTION.....	21
BLOCK DIAGRAM.....	21
POWER SUPPLY.....	22
AUDIO INPUT.....	22
PLL/VCO.....	23
DRIVER AND FINAL RF STAGE.....	23
DIRECTIONAL COUPLER.....	23
10 – TECHNICAL DATA.....	25
RADIO FREQUENCY SECTION.....	25
LOW FREQUENCY SECTION.....	25
GENERAL CHARACTERISTICS.....	26
11 – DESCRIPTION OF OPTIONAL MODULES.....	27
BUS BOARD.....	27
CARD DIMENSIONS.....	27
MPX AND SCA INPUTS CARD.....	28
RDS CARD (OPTION R).....	28
MONO INPUT CARD (OPTION M).....	29
STEREO INPUT CARD (OPTION S).....	29
MPX GENERATOR (STEREO ENCODER).....	30
12 – OPERATING INSTRUCTIONS.....	31

SWITCH ON:	31
DESCRIPTION OF THE GRAPHICS INTERFACE	32
SELECTING TRANSMISSION FREQUENCY	33
SELECTING RF POWER	34
AUDIO PROGRAMMING.....	36
SYS PROGRAMMING	38
RDS OPTIONS (QUICK GUIDE).....	40
RDS RADIO TEXT MESSAGE.....	42
RDS MESSAGES	44
RDS FREQUENCIES	45
DEVIATION MEASUREMENTS	46
13 – MAINTENANCE	49
GENERAL MAINTENANCE RULES	49
GENERAL MAINTENANCE	49
14 – RDS CARD (OPTION R).....	51
INTRODUCTION	51
RDS SYSTEM.....	52
RDS ENCODER.....	53
ENCODER PROGRAMMING.....	55
PS MESSAGES	57
ENTERING THE PS MESSAGES.....	58
ALTERNATIVE FREQUENCIES.....	59
METHOD A/B	59
ENTERING ALTERNATIVE FREQUENCIES	60
PROGRAM IDENTIFICATION	61
PROGRAM IDENTIFICATION PI.....	61
PROGRAM TYPE PTY AND DECODER IDENTIFICATION	62
TA-TP-MS	62
RADIO TEXT	63
EON MESSAGE	64
TIME & CLOCK DATA	66
EXIT.....	67
TECHNICAL DATA	68
INSERTING THE RDS CARD.....	68
15 – CIRCUIT DIAGRAMS	69
POWER SUPPLY DIAGRAM	69
“POWER SUPPLY 1” CIRCUIT DIAGRAM	70
“POWER SUPPLY 2” CIRCUIT DIAGRAM	70
“POWER SUPPLY 3” CIRCUIT DIAGRAM	71
“POWER SUPPLY 4” CIRCUIT DIAGRAM	71
“POWER SUPPLY 5” CIRCUIT DIAGRAM	71
AUXILIARY POWER SUPPLY ASSEMBLY DRAWING (POWER SUPPLY 1-5)	72
POWER SUPPLY CIRCUIT DIAGRAM.....	73
POWER SUPPLY ASSEMBLY DRAWING.....	74
AGC CIRCUIT DIAGRAM.....	75
AGC ASSEMBLY DRAWING	76

FUSE BOARD CIRCUIT DIAGRAM.....	77
FUSE BOARD ASSEMBLY DRAWING	78
FRONT PANEL CIRCUIT DIAGRAM	79
FRONT PANEL CIRCUIT BOARD ASSEMBLY DRAWING	80
VCO CIRCUIT DIAGRAM.....	81
VCO ASSEMBLY DRAWING	82
PLL CIRCUIT DIAGRAM	83
PLL ASSEMBLY DRAWING.....	84
RF OUTPUT FILTER CIRCUIT DIAGRAM.....	85
RF OUTPUT FILTER ASSEMBLY DRAWING	85
OUTPUT AMPLIFIER CIRCUIT DIAGRAM	86
OUTPUT AMPLIFIER ASSEMBLY DRAWING	87
DRIVER CIRCUIT DIAGRAM	88
DRIVER ASSEMBLY DRAWING.....	89
DIRECTIONAL COUPLER CIRCUIT DIAGRAM	90
DIRECTIONAL COUPLER ASSEMBLY DRAWING	91
DIRECTIONAL COUPLER AMPLIFIER CIRCUIT DIAGRAM.....	92
DIRECTIONAL COUPLER AMPLIFIER ASSEMBLY DRAWING	93
MPX INPUTS CARD CIRCUIT DIAGRAM	94
MPX INPUTS CARD ASSEMBLY DRAWING.....	95
OPTIONAL CARD BUS CIRCUIT DIAGRAM.....	96
CARD BUS ASSEMBLY DRAWING.....	97
STEREO INPUT CIRCUIT DIAGRAM.....	98
STEREO INPUT ASSEMBLY DRAWING	99
CLIPPER CIRCUIT DIAGRAM	100
CLIPPER ASSEMBLY DRAWING.....	101
MONO INPUT CIRCUIT DIAGRAM.....	102
MONO INPUT ASSEMBLY DRAWING	103
STEREO ENCODER (MPX GENERATOR) CIRCUIT DIAGRAM	104
STEREO ENCODER ASSEMBLY DRAWING	105
RDS CONTROL CIRCUIT DIAGRAM	106
RDS CARD ASSEMBLY DRAWING.....	107
CANNON XLR WIRING	108
16 – GENERAL CONDITIONS OF SALE	109

2 – INTRODUCTION

Thank you for choosing ELENOS.

The ETG 150 Exciter is a transmitter designed for Frequency Modulation Broadcasting in the band 87.5-108 MHz. The final stage uses solid state components capable of developing up to 150W. The display situated on the front panel allows control of the most important values and easy adjustment of operational parameters. The modular design gives a high degree of customisation and allows straightforward upgrading via modules which are easily added at any time.

Great care has been taken during the design phase of the protection circuitry to ensure compatibility with other manufacturer's equipment. Optimum performance is obtained, however, when the unit is used with other equipment from the ELENOS range of products.

The ETG 150 has been designed to ensure that its performance remains constant without requiring special maintenance. In fact servicing is limited to periodic checking that the fan is working correctly.

Operation of the unit is very simple and intuitive. Nevertheless, careful reading of this manual is recommended before the ETG 150 Exciter is operated.

3 – SAFETY

!! WARNING !!

Your unit is a radio frequency power transmitter

Do not attempt to service the equipment yourself.

Opening or removing the cover or other parts of the chassis can expose the operator to lethal voltages.

In the event of malfunction or operational problems, isolate the equipment from the supply and contact your distributor or ELENOS Customer Service.

!! WARNING !!

This manual is a general guide for trained and qualified personnel, familiar with the potential dangers inherent in operating electrical and electronic circuitry. This manual does not contain an exhaustive description of all the safety precautions to be observed by personnel using this or other equipment.

The installation, operation, maintenance and use of this unit carries a risk both for users and equipment alike and must only be used by qualified personnel exercising due care and attention.

ELENOS s.r.l. will not be responsible for injury or damage resulting from improper use or use by unqualified personnel or those not properly trained to perform such procedures.

Local Fire and Building Regulations must be observed during the installation and operation of this unit.

This unit has been designed and developed in full compliance with FCC, CEI, CENELEC and ETSI regulations and CEE recommendations regarding active and passive safety.

!! WARNING !!

In case of emergency, ensure that the supply is disconnected before attempting any other procedure

The currents and voltages present in this unit are hazardous; personnel should always observe safety norms.

- 1) *Do not open the unit for internal inspection of any sort, without first ensuring that all connections to and from the unit have been disconnected from the electrical supply and all other equipment!*
- 2) *Always use isolated test instruments and earthing straps for high voltages before use.*
- 3) *Do not approach the equipment with thin or pointed metallic objects and do not attempt to insert such objects through the ventilation grills, even if only for cleaning purposes.*
- 4) *Never attempt internal adjustments, maintenance procedures or servicing when alone or when tired.*
- 5) *Some components within the equipment contain TOXIC SUBSTANCES; if, as a result of a visual inspection, components appear damaged or cracked or in any way compromised, proceed with maximum caution with regard to physical contact with hands etc. In particular, the radio frequency power components contain the highly dangerous substance, beryllium oxide.*

WARNING! BERYLLIUM OXIDE IS DEADLY

4 – PRECAUTIONS

Cleaning operations

Disconnect the supply

Do not use liquids or detergent sprays

Only use a lightly dampened soft cloth or a brush.

For persistent dust, use a compressed air line at moderate pressure (< 5 atm)

Siting the Unit

Do not position the unit in areas prone to spillage of water or other liquids.

Do not obstruct the front/rear panel ventilation grills.

Ensure that there is a distance of at least 20cm around the unit to allow ventilation.

Do not position the unit close to sources of heat, or in enclosed environments without ventilation.

Power Supply

The unit must be powered only at the specified voltage. If in doubt, refer to your distributor or Elenos Customer Service.

Ensure that the current capacity of whatever power supply extension cables are used, is sufficient.

Switching On

Do not switch the unit on, or handle in any way, if it is not completely closed on all sides and if not connected to an efficient earth.

Switching the unit on with panels removed is allowable only and exclusively by qualified personnel, familiar with the risks associated with the currents, voltages and high power RF present inside.

First Aid Posters

It is recommended that a poster with clear first aid instructions for the treatment of victims of accidents at work, is hung in environments containing electrical equipment. Provide first aid kits – invaluable in the event of personal injury. Have plans ready in the event of emergencies including lists of telephone numbers and the means of contacting emergency services, private or public, which are readily visible to all personnel working in the area.

5 – FIRST AID

Personnel involved with the installation, operation, maintenance or service of this unit, must be familiar with the theory and practice of First Aid.

The following is not a complete first aid guide, but is only a summary to be used as a reference.

It is the responsibility of all those that use this unit to be capable of offering an adequate level of first aid in order to avoid preventable deaths.

Treatment of electrical burns

Extensive burns and skin cuts

- Cover the area with a sheet or clean cloth.
- Do not burst blisters. Remove clothing, remove any clothing material which is attached to the skin and apply a suitable cream.
- Treat the casualty according to the type of shock sustained.
- Get the casualty to hospital as quickly as possible.
- If limbs are affected, keep them in an elevated position.

ATTENTION :

If medical assistance is not available within one hour and the casualty is conscious and is not vomiting, administer a solution of salt and soda: 1 full teaspoon of salt and half a teaspoon of bicarbonate of soda for every 250ml of water (neither hot nor cold). Allow the casualty to sip slowly about 4 times (1/2 glass) over a 15 minute period. Stop if vomiting occurs. Do not administer alcohol.

Less severe burns (1st and 2nd degree)

- Apply a cold compress (not iced) using a cloth which is as clean as possible.
- Do not burst blisters. Remove clothing, remove any clothing material which is attached to the skin and apply a suitable cream.
- Dress them in clean, dry clothes if necessary.
- Treat the casualty according to the type of shock sustained.
- Get the victim to hospital as quickly as possible.
- If limbs are affected, keep them in an elevated position.

Treatment of electric shocks

If the casualty has lost consciousness:

Lay the casualty on their back on a rigid surface

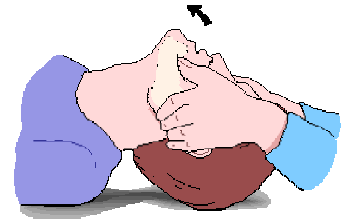

A) Air ways :

if unconscious, open the breathing channels
push chin up and forehead backwards
open the mouth if necessary
check breathing



B) Breathing :

if not breathing, start artificial respiration
tilt the head upwards
close the nostrils
place mouth over mouth of casualty
perform 4 quick breaths
remember to start breathing immediately

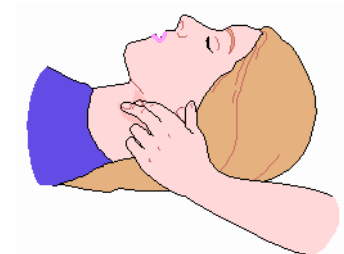

C) Circulation :

check the heart beat
in the absence of a heart beat, start cardiac massage
press the sternum every 1/2 -2 seconds
if only one first-aider is available, press about 15 times during an 80 second period, plus 2 quick mouth-to-mouth breaths.
if 2 first-aiders are available, press about 5 times during a 60 second period, plus one mouth-to-mouth breath.



**ATTENTION: DO NOT INTERRUPT THE RHYTHM OF CARDIAC COMPRESSION
WHILE THE SECOND PERSON IS GIVING ARTIFICIAL
RESPIRATION**

CALL A DOCTOR AS SOON AS POSSIBLE

If the casualty is conscious

cover the casualty with a blanket.
reassure the casualty.
loosen clothing and lay the casualty down.

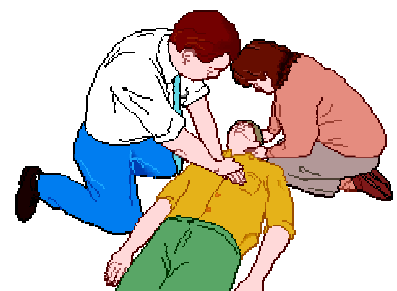

6 – INSTALLATION

Introduction

This chapter contains the information necessary for the installation and preliminary checks on the ETG 150 Exciter.

Unpacking

Remove the unit from its packaging and, before performing any operation, check that the unit has not suffered damage during transport, and that all the buttons and connectors present on the front and rear panels are usable.

Installation

1. Install the unit in such a way that it is accessible from all sides.
2. Ensure that the site has an efficient earthing system.
3. Verify that the antenna system is matched.
4. Ensure that any amplifier that forms part of the system is connected to the antenna system.
5. Connect the Exciter inputs according to the type of operation required:
 - the monophonic signal to the XLR connector on the mono input card.
 - the stereophonic signal (low frequency) to the left and right XLR connectors on the stereo input card.
 - the stereophonic signal (wide-band) to the MPX connector on the MPX and SCA input card.
 - The RDS signal to one of the two SCA connectors on the MPX and SCA input card.
 - If the RDS card is fitted, the wide-band stereo signal should be connected to the MPX input of the RDS card, thus the MPX+RDS output should be connected to the MPX input of the MPX and SCA input card.
6. Connect the power supply cable.
7. Connect a dummy load to the RF output, capable of dissipating 150W continuously.
8. Switch on the Exciter.
9. Follow the configuration instructions as described in this manual.
10. Switch off the Exciter.
11. Disconnect the dummy load.
12. Connect the RF output to the input of any subsequent amplifier or antenna system.
13. Switch on the amplifier, if present.
14. Switch on the Exciter.
15. Check the levels displayed by the Exciter and the amplifier instruments to ensure correct operation.

7 – FRONT VIEW

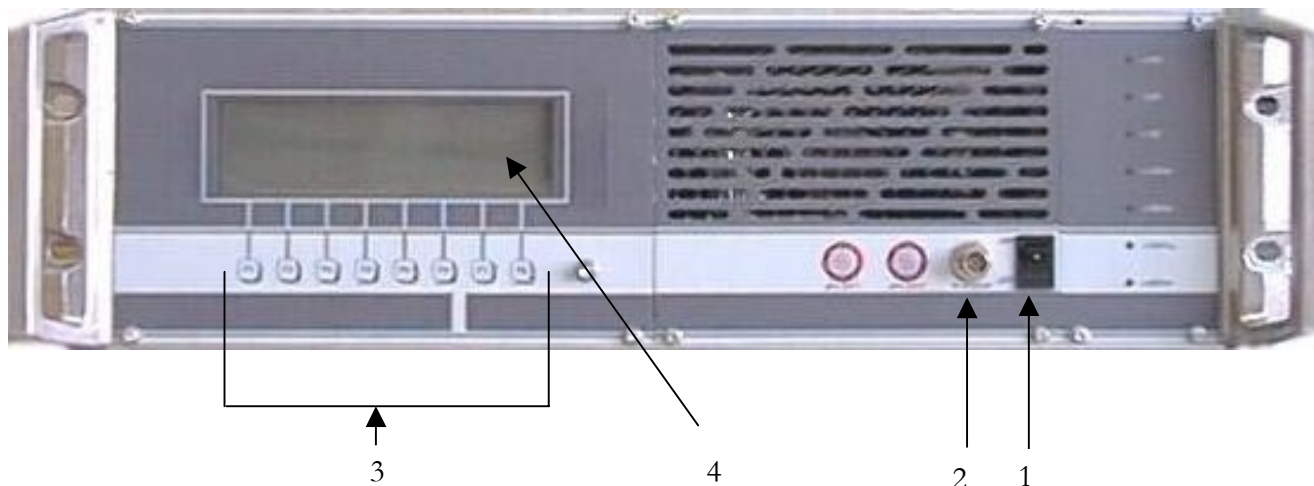

Front Panel description

1. Power switch
2. RF monitor output (approx. level 0 dBm per 150W of output power)
3. Buttons for operational programming
4. Functional display

8 – REAR VIEW

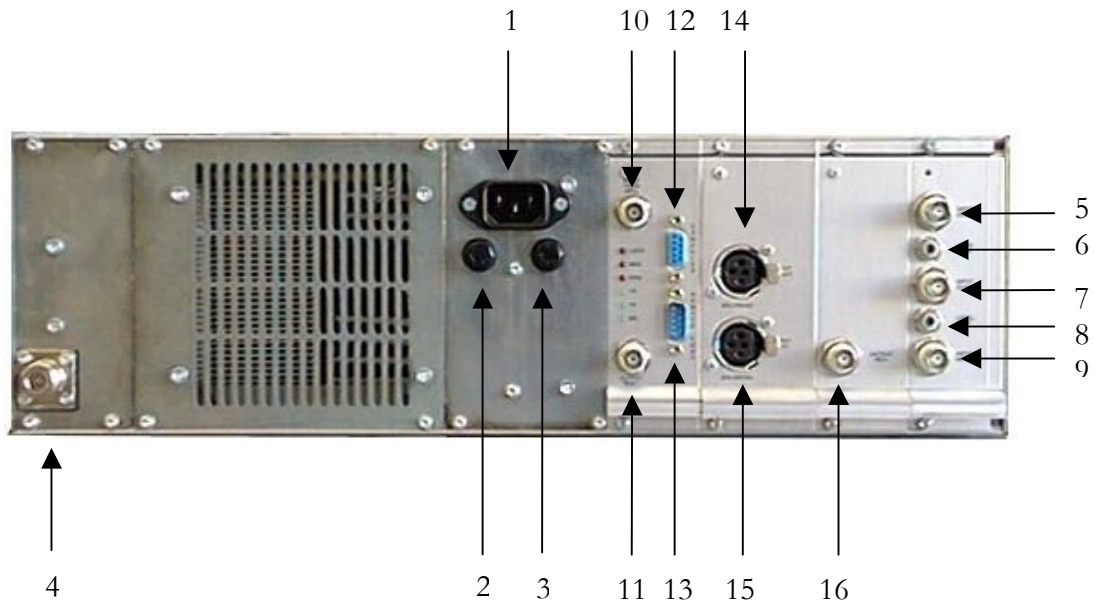

Rear panel description

1. 220V single-phase 50 Hz Power Input Connector
2. Line fuse
3. Line fuse
4. RF Output Connector (type N female)

MPX and SCA Input Cards

5. SCA2 input connector (BNC female)
6. SCA2 level adjustment
7. SCA1 input connector (BNC female)
8. SCA1 level adjustment
9. MPX input connector (BNC female)

RDS Card

10. BNC connector for mono or stereophonic input signal
11. BNC connector for MPX and/or MPX + RDS output signal
12. Flat 10 pin connector Personal Computer serial link
13. Flat 10 pin connector remote keyboard connection

Stereo Input Card

14. XLR connector: right channel balanced input
15. XLR connector: left channel balanced input

Stereo Encoder Card

16. BNC connector for supplying the MPX signal to other transmitters

9 – GENERAL DESCRIPTION

Introduction

This technical manual contains information regarding the operation, use and maintenance of the ETG 150 Exciter.

The ETG 150 operates in the 87.5 – 108 MHz frequency band and can develop a maximum controlled power output of 150W.

All operational controls are directly accessible on the front panel whilst all the connectors are situated on the rear panel.

The exciter can be used for monophonic, stereophonic and composite multiplex transmission.

Block Diagram

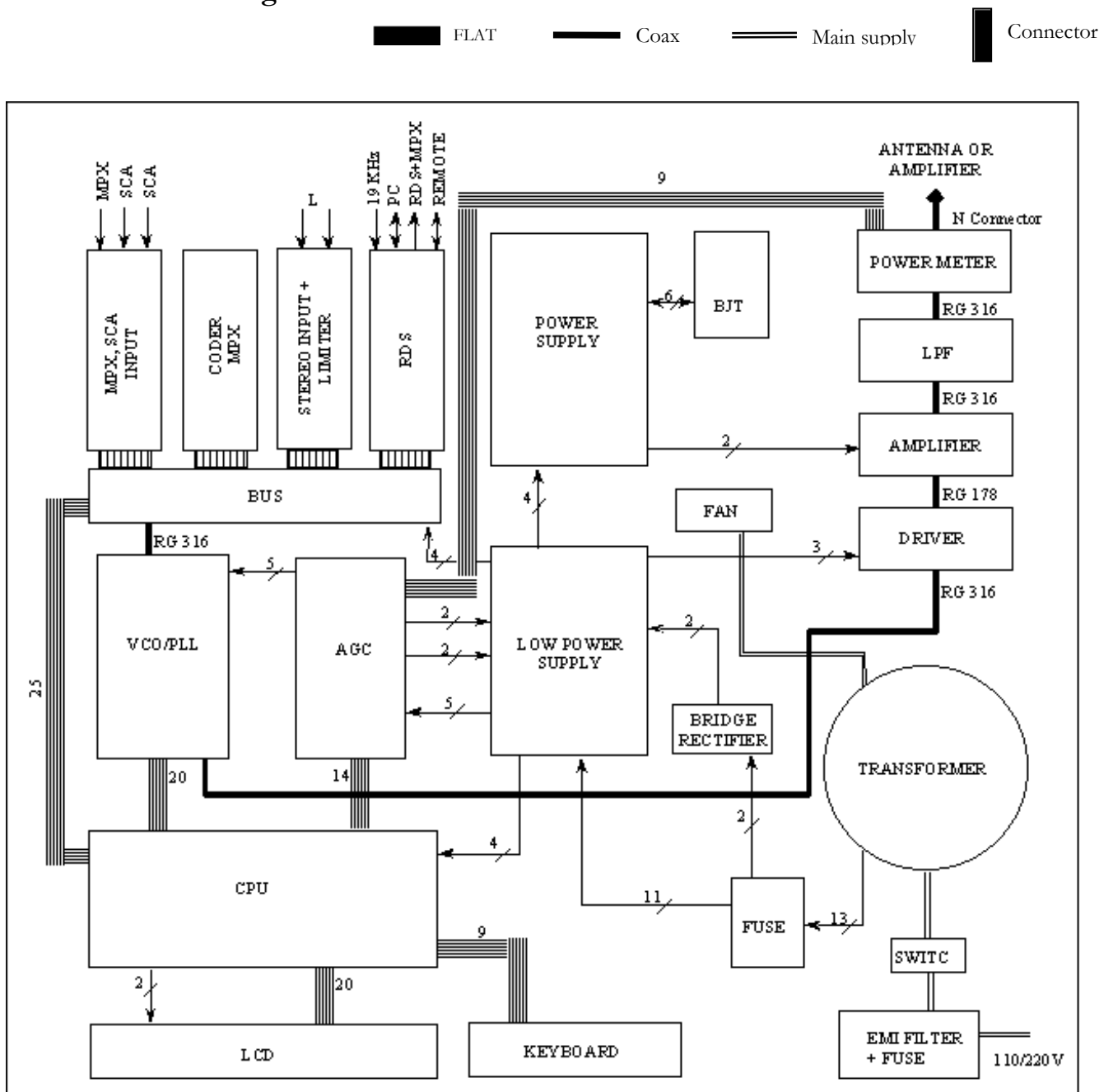

Power Supply

The ETG 150 Exciter uses a linear power supply in order to minimise the interference distributed to the various other modules via the supply cables. It also includes an efficient line filter upstream of the transformer which prevents interference being conducted.

Use of discreet component technology allows straightforward replacement in the event of a fault.

The power supply generates 7 separate supplies of which one is controlled by the CPU from 0 to 40V; see table below.

The board is supplied by a toroidal transformer with two primary windings of 115V connected in series for 230V supplies, or in parallel for 115V supplies. The 6 secondary circuits are: 19V ($\rightarrow +18 V_{PLL}$), 16V ($\rightarrow +12 V_{RF}$), 25V ($\rightarrow +18 V_{RF}$), 9V ($\rightarrow +5 V$), 15V+15V ($\rightarrow \pm 12 V$), 45V ($\rightarrow +40 V_{RF}$).

The power supply's fuse board is accessible by removing the front panel, to the side of the display, and is equipped with leds which light in the event of the corresponding fuse being blown. The two line input fuses are located on the rear panel below the VDE socket.

Power Supply Voltage	Board supplied	Protection	Fuse
+12 V	CPU, PLL, Bus Board, Auxiliary functions	Current protection	1,6 A
-12 V	CPU, PLL, Bus Board, Auxiliary functions	Current protection	1,6 A
+5 V	CPU, PLL, Bus Board	Voltage protection Current protection	2,5 A
+18 V _{RF}	RF driver stage	Current protection	2,5 A
+12 V _{RF}	RF driver stage	Current protection	2,5 A
+18 V _{PLL}	PLL	Current protection	1 A
+40 V _{RF}	RF power amplifier	Current protection	6,3 A

Audio input

The audio signal can be connected to the MPX inputs card (processed stereo signal to BNC connector, or SCA signal), to the optional stereo input card (right and left channel inputs to XLR connectors), or to the optional mono input card (1 mono input channel on XLR connector).

If the signal comes from the MPX card, it will be processed by such and then passed directly to the audio input of the PLL.

If, instead, the signal comes from the stereo or mono input cards, the stereo encoder card (optional) will be required in order to process the audio signal in base-band in an MPX signal (wide-band stereo). The signal is then passed to the PLL input.

The ETG 150 Exciter is also designed for the optional DSP card that can process the signal before it is passed to the PLL.

Naturally, all adjustments required by this card can be performed in software by inputting values via the display.

For further information regarding the plug-in cards, refer to the paragraph entitled "Description of optional modules"

PLL/VCO

The PLL board generates the frequency modulated RF signal via phase-lock synthesis. The Voltage Controlled Oscillator (VCO), mounted on the same PLL board, makes use of very low noise components and separation stages in order to obtain a signal with very low phase noise.

The reference frequency is generated by a temperature-compensated oscillator, with a maximum deviation of 1 ppm (in the first year). An ultra high precision reference (0.1 ppm/year) can be supplied on request.

Driver and final RF stage

The oscillator output (approx. +8dBm) drives the RF amplification stages to obtain a maximum output of 150W. The amplifiers use mos-fets and are designed to be unconditionally stable at any output and for any load. A ninth order Chebychev low-pass filter guarantees reduction of harmonic components to within international standards. A control circuit regulates the output power and maintains it to within ± 0.1 dB max. across the whole operating band and reduces it progressively in the event of excessive ROS, down to 10W, a level at which the amplifier can continue operating with infinite ROS and any phase angle.

Directional Coupler

The directional coupler ensures a power reading with a maximum error of 1W in 150, within the temperature range 0 to 70°C. The rugged design, housed in a milled aluminium box, and the high quality components used, ensure operation even in hostile environmental conditions and is particularly resistant to mechanical shock.

10 – TECHNICAL DATA

Radio Frequency Section

PARAMETER	ETG 150 Values
FREQUENCY BAND	87,6 ÷ 107,9 MHz in 10KHz steps
OUTPUT POWER	0-150 Watt continuously variable
OUTPUT POWER STABILITY	Within +/- 0,1dB
FINAL STAGE TECHNOLOGY	MOSFET
OUTPUT IMPEDANCE	50 Ω
OUTPUT CONNECTOR	Standard type "N"
HARMONIC SUPPRESSION	> 70 dB
SPURIOUS COMPONENT SUPPRESSION	> 80 dB
FREQUENCY STABILITY	Better than 1 ppm: (0 - +40 °C) in the first year
TYPE OF MODULATION	F3 direct FM modulation of the RF oscillator at the fundamental frequency
RESIDUAL AM	Asynchronous: 0,2 % Synchronous: 0,1 % (typical values)

Low Frequency Section

PARAMETER	ETG 150 Values
VSWR PROTECTION	Progressively reduced to a safe level
AUTOMATIC GAIN CONTROL	Regulates the output power to the programmed level
INTERMODULATION DISTORTION	< 0,05% Measured with composite 1 KHz and 1.3 KHz tones, 1:1 ratio at 100% modulation.
FREQUENCY DEVIATION	± 75 KHz adjustable in 0.1 dB steps
THD+N	< 0,03% @ 1 KHz
FM S/N ratio with weighted CCIR filter	-72dB ref. to ± 75 KHz dev.
PRE-EMPHASIS	50/75 μ s $\pm 0,1$ dB
FREQUENCY RESPONSE	Mono[1]: $\pm 0,15$ dB (30 Hz - 15 KHz) -45 dB at 19 KHz Stereo[2]: $\pm 0,15$ (30 Hz - 15 KHz) -45 dB at 19 KHz MPX: $\pm 0,1$ dB (30 Hz - 100 KHz) SCA 1,2,3: ± 1 dB (20 KHz - 100 KHz)
STEREO SEPARATION [2]	65dB @1KHz typical values
PILOT TONE [2]	Frequency: 19 KHz ± 1 Hz deviation 7,5KHz adjustable
AUDIO L/R INPUT MODULE[2]	Input Impedance: 10 K Ω - 600 Ω (selectable) balanced input Frequency response: 20 Hz - 15 KHz Adjustment: -12 - +12 dB in 0,1 dB steps Connectors: XLR female
ATTENUATION AT 19KHz	45dB
MPX INPUT MODULE	Input Impedance 10 K Ω unbalanced input Frequency response: 30 Hz ÷ 100 KHz Adjustment: -12 ÷ +12 dB a passi di 0,1 dB Connector: BNC female
SCA INPUT	Input Impedance 10 K Ω unbalanced input Frequency Response: 20 KHz ÷ 100 KHz Connector: BNC female

[1] optional module available on request

[2] ETG150/S

General Characteristics

PARAMETER	ETG 150 Values
ENVIRONMENTAL CONDITIONS	Temperature: (Operational): 0 to +45 °C (Non Operational): -20 to +50 °C Humidity: (Operational): 95% at 40 °C (Non Operational): 90% at 65 °C Altitude: (Operational): >4600 metres (Non Operational): >15000 metres
WEIGHT	21.5 Kg approx
DIMENSIONS	50 x 14 x 50 cm
POWER SUPPLY	110 - 240 Volt
POWER CONSUMPTION	300 Watt typical at maximum power output.
COOLING	Fan ventilation

11 – DESCRIPTION OF OPTIONAL MODULES

The ETG 150 Exciter is designed to accept several optional modules:

1. RDS board
2. Stereo/Mono input board
3. MPX generator board (stereo encoder)

The following versions are available:

- **Basic version:** MPX and SCA inputs board
- **option R:** RDS board + MPX and SCA inputs board
- **option M:** mono input board + MPX and SCA inputs board
- **option MR:** mono input board + RDS board + MPX and SCA inputs board
- **option S:** stereo input board + stereo encoder + MPX and SCA inputs board
- **option SR:** stereo input board + stereo encoder + RDS board + MPX and SCA inputs board

Each board can only be inserted in its dedicated slot (bus board).

BUS Board

Function: allows insertion of the various optional boards.

Board connectors:

Connector 1: MPX and SCA inputs board.

Connector 2: mono input board or MPX generator board.

Connector 3: stereo input board.

Connector 4: RDS board.

Other connectors located on the board:

D-type connector (P3): serial data output.

D-type connector (P1): parallel port interfacing with the microcontroller board

D-type connector (P2): power supply.

BNC connector: MPX generator board output – direct to VCO

Boards dimensions

The width of the slot to accommodate each card is different to prevent insertion of the wrong card.

- *connector 1* board width: 6 TE
- *connector 2* board width: 8 TE
- *connector 3* board width: 10 TE
- *connector 4* board width: 8 TE

Care should, however, still be taken not to insert a narrow board into a slot designed for a wider board.

The microprocessor will still recognise any incorrectly inserted board and will not allow any setup to be performed.

N.B. Insertion of any board should only be performed with the unit switched off.

MPX and SCA inputs card

Function: accepts an MPX (wide-band) input signal, i.e. provides the transmitter with a stereo signal from an external stereo encoder. This card is always present.

The card features 2 SCA inputs, one of which can be used as an RDS data input.

The two unbalanced inputs for SCA signals accept input frequencies up to 200 KHz.

Card position: *connector 1*

Adjustment:

- trimmer adjustment of MPX input level (0 dB in → 0 dB out)
- software adjustment of MPX input level
- software adjustment of input level of signal from other cards on the bus (this adjustment is in steps of 1 KHz deviation or in steps of 0.1 dB, depending on the programme run by the microcontroller)
- multiturn trimmer adjustment of SCA levels
- software selection of input type (bus signal or external MPX signal)
- software ON/OFF control of SCA inputs

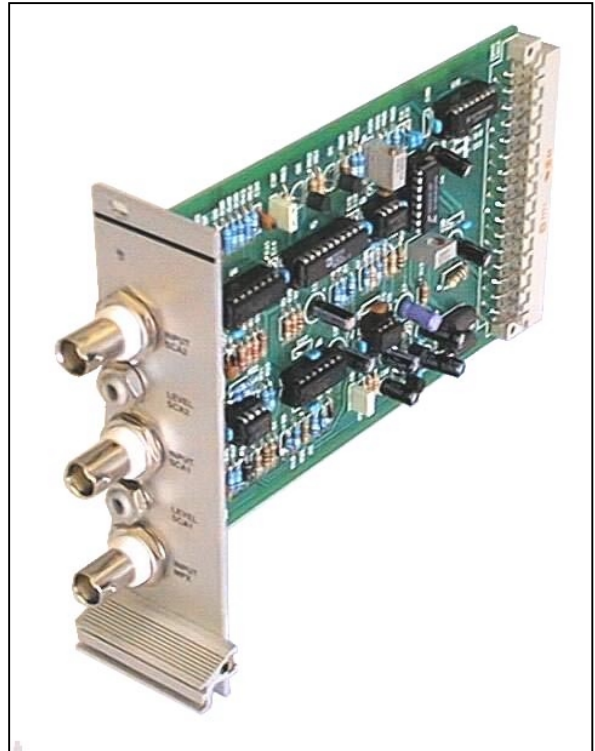

The card is also able to provide the microcontroller with the MPX signal, suitably processed for the MPX signal level to be displayed in bar-graph form with the corresponding dBV value.

The inputs are over-voltage protected.

The inputs are unbalanced on the BNC connector (10KHz impedance).

RDS Board (optional)

See chapter entitled “RDS Board (option R)” in this manual.

Mono Input Board (optional)

Function: to process the audio signal for monophonic transmission. In particular to limit the signal in the 0-15KHz band via a 7th order (>50dB a 19KHz) FDNR elliptical filter and to limit the maximum deviation to 75 KHz with software controlled clipping.

Board position: *connector 2*

Adjustment:

- jumper selection of pre-emphasis value (50/75 μ sec)
 - jumper ON/OFF control of pre-emphasis
 - software ON/OFF control of pre-emphasis, filter and clipper
 - software gain adjustment in 3dB steps. NB: if the signal is lower than required, adjustment is made to the MPX card.
 - jumper selection of input impedance (600 Ω /10K Ω)
- The input is balanced on the XLR connector.

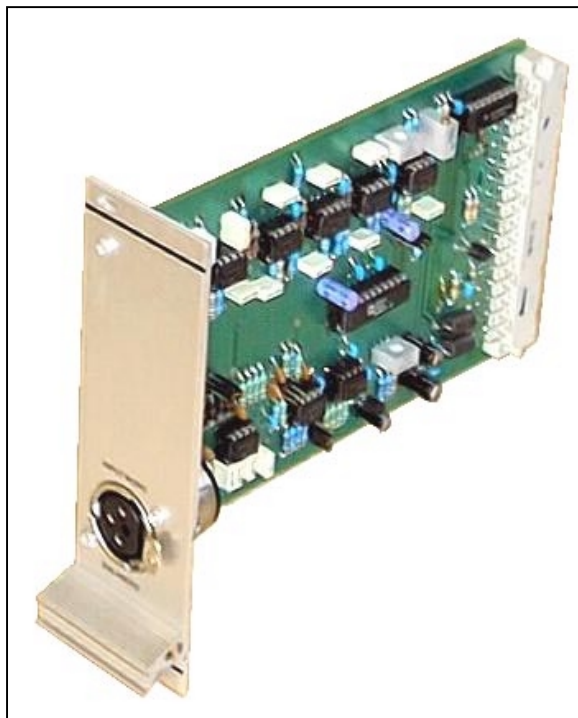

Stereo Input Board (ETG150/S)

Comprises two modules:

Function: to process the audio signal for stereophonic transmission.

Board position: *connector 3*

Adjustment:

- jumper selection of pre-emphasis value (50/75 μ sec)
- jumper ON/OFF control of pre-emphasis
- software ON/OFF control of pre-emphasis, filter and clipper
- software level adjustment in 0.5 dB steps on both channels
- jumper selection of input impedance (600 Ω /10K Ω)

The board also provides the microcontroller with a stereo signal processed in such a way that the level can be displayed in bar-graph form with the corresponding dBu value.

The inputs (R and L) are balanced on the XLR connectors.

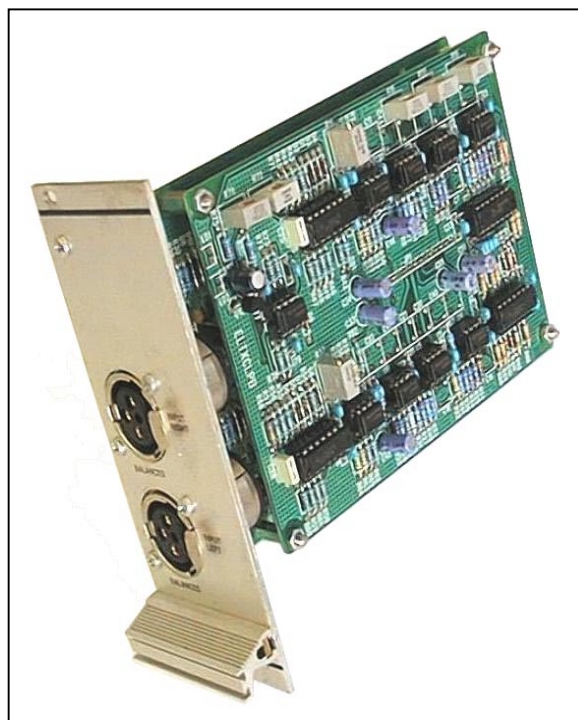

MPX Generator (stereo encoder) (ETG150/S)

Function: to generate the MPX signal.

The card generates digitally the carrier pilot at 19 KHz and the suppressed carrier.

Board position: *connector 2*

Adjustment:

- trimmer adjustment of pilot tone (8-12 %)
- trimmer adjustment of the threshold at which the clipping of the MPX signal begins before being summed with the pilot carrier
- jumper ON/OFF control of the clipper
- trimmer adjustment of MPX level at the board output
- trimmer adjustment of pilot tone phase with respect to the suppressed carrier
- double trimmer adjustment of the equalisation of the L+R summed signal for maximum separation
- trimmer adjustment of the suppressed carrier level (always greater than 90 dB)
- software ON/OFF control of clipper
- software ON/OFF control of pilot carrier
- software selection of stereo/mono modes



The board has no external inputs (all inputs via the bus) but can have a BNC connector added to supply the MPX signal to other transmitters.

12 – OPERATING INSTRUCTIONS

SWITCH ON:



- A window appears indicating the status of the AUDIO BUS.
- The on-board computer performs a system check to determine which optional board have been fitted.
- An 8 second countdown begins before the Exciter develops power.



Push (during the countdown):

- **Any key** to start without generating power.
- or
- **F1+F8** to terminate the countdown.

When the countdown has terminated, the main window appears (with personalised logo by request).

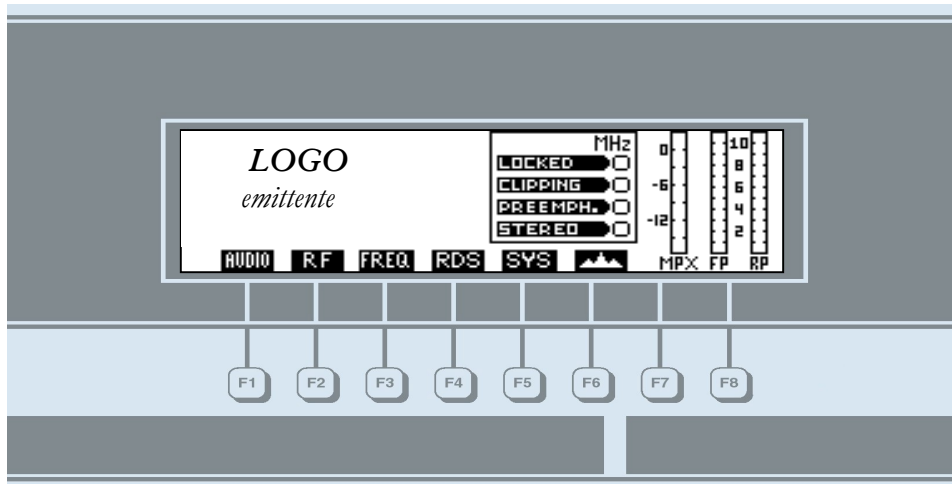

Description of the graphics interface

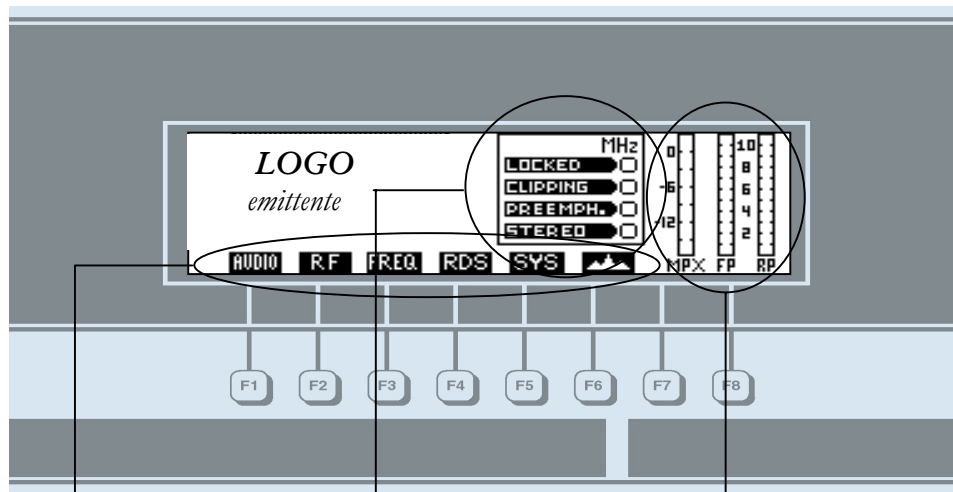

On the right side there are three vertical bars indicating:

- MPX signal.
- Reflected output power.
- Forward output power.

In the centre the following information is displayed:

- Transmission frequency of the unit.
- PLL status (LOCKED or UNLOCKED).
- Status of the CLIPPER circuit (active when the L or R input signals are too high).
- Insertion of the Pre-emphasis circuit
- Transmission mode - Stereo or Mono.

The bottom of the display:

- F1 – (AUDIO) to enter the Audio inputs display and adjustment window
- F2 – (R.F.) to enter the power display and adjustment window.
- F3 – (FREQ) to enter the frequency display and adjustment window.
- F4 – (RDS) to enter the RDS parameter display and adjustment window.
- F5 – (SYS) to enter the ETG150 parameter display and adjustment window.
- F6 – () to enter the modulation display window

Selecting transmission FREQUENCY

(not valid in Italy):

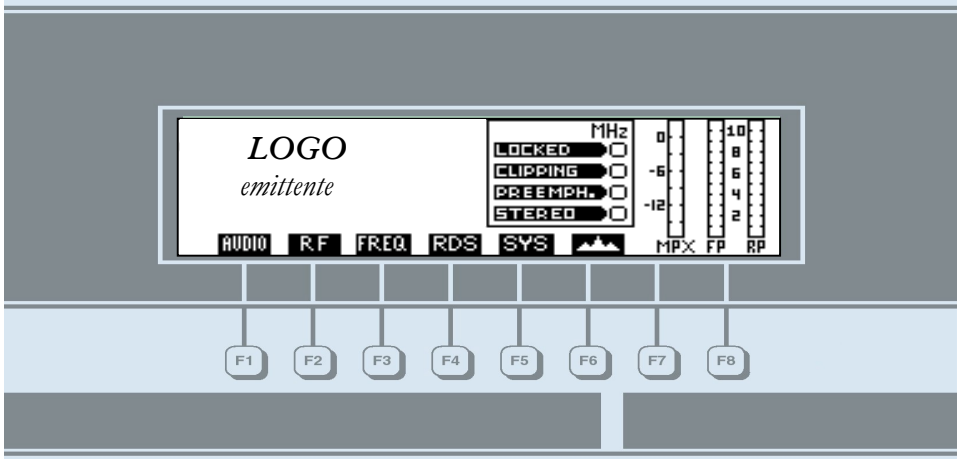

Push:

- F3 (**FREQ**) to display the frequency programming window

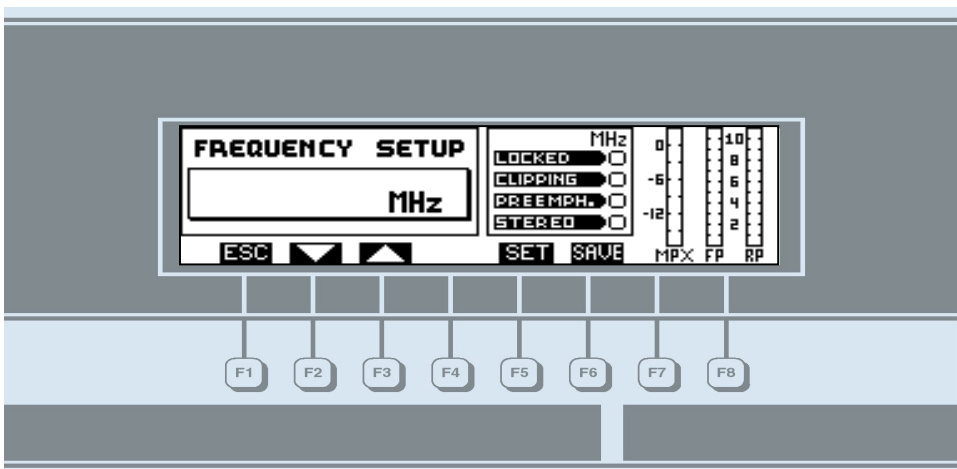

Push:

- F5 (**SET**) to enable frequency selection
- F2 (**▲**) or F3 (**▼**) to increase or decrease the programmed frequency.
- F6 (**SAVE**) to save the new value. The ETG 150 stops developing power, changes frequency and starts developing power at the new frequency.
- F1 (**ESC**) to exit and return to the main menu.

Selecting RF POWER

Push:

- F2 (**RF**) to display the radio frequency power programming window.

Stereo version

Push:

- F4 (**PWR**) to enable power changes
- F2 (**▲**) or F3 (**▼**) per select the power value.
- F6 (**SAVE**) to save the new value.
- F1 (**ESC**) to exit and return to the main menu.

This window shows the MPX, Forward Power and Reflected Power measurements.

MPX bar-graph:

- Displays the dBu value of the Stereo Decoder composite output signal summed with the RDS and SCA signals, if present.
- Displays the signal level and holds peak values for a few seconds.

FP, RP bar-graph:

- Forward and reflected power values, displayed in watts.
- Graphic display of power.
- Power display during selection of a new value.

Mono version

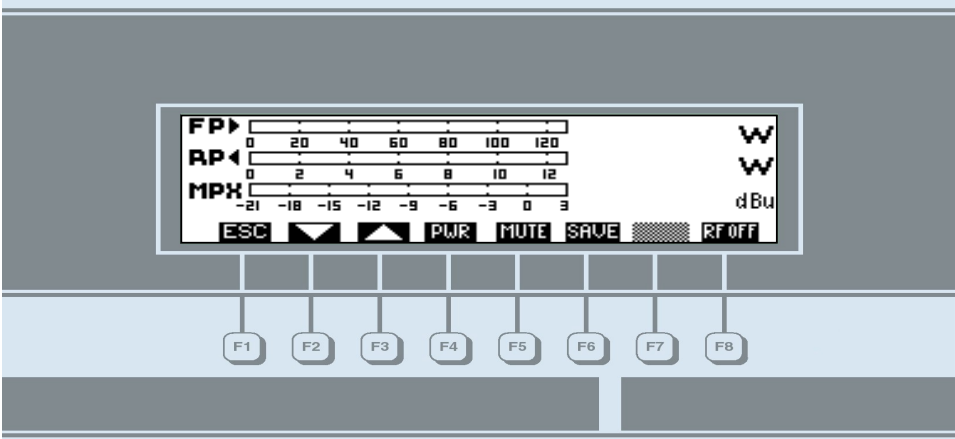

Push:

- F4 (**PWR**) to enable changes to output power
- F2 (**▲**) or F3 (**▼**) to increase or decrease programmed power.
- F6 (**SAVE**) to save the new value.
- F1 (**ESC**) to exit and return to the main menu

NB: All versions



Push :

- F8 (**RF OFF**) to disable RF output power during this operation.
- F8 (**RF ON**) to enable RF output power.
- When F1 (**ESC**) is pressed, output power will be enabled, regardless of the ON/OFF status.

AUDIO programming

Push:

- F1 (**AUDIO**) to display the audio programming window.

Stereo version

Push :

- F4 (**R/L**) to enable programming of left or right channels
- F2 (**▲**) or F3 (**▼**) to select the input level.
- F6 (**SAVE**) to save the configuration.
- F1 (**ESC**) to exit and return to the main menu
- F5 (**MUTE**) to isolate the inputs

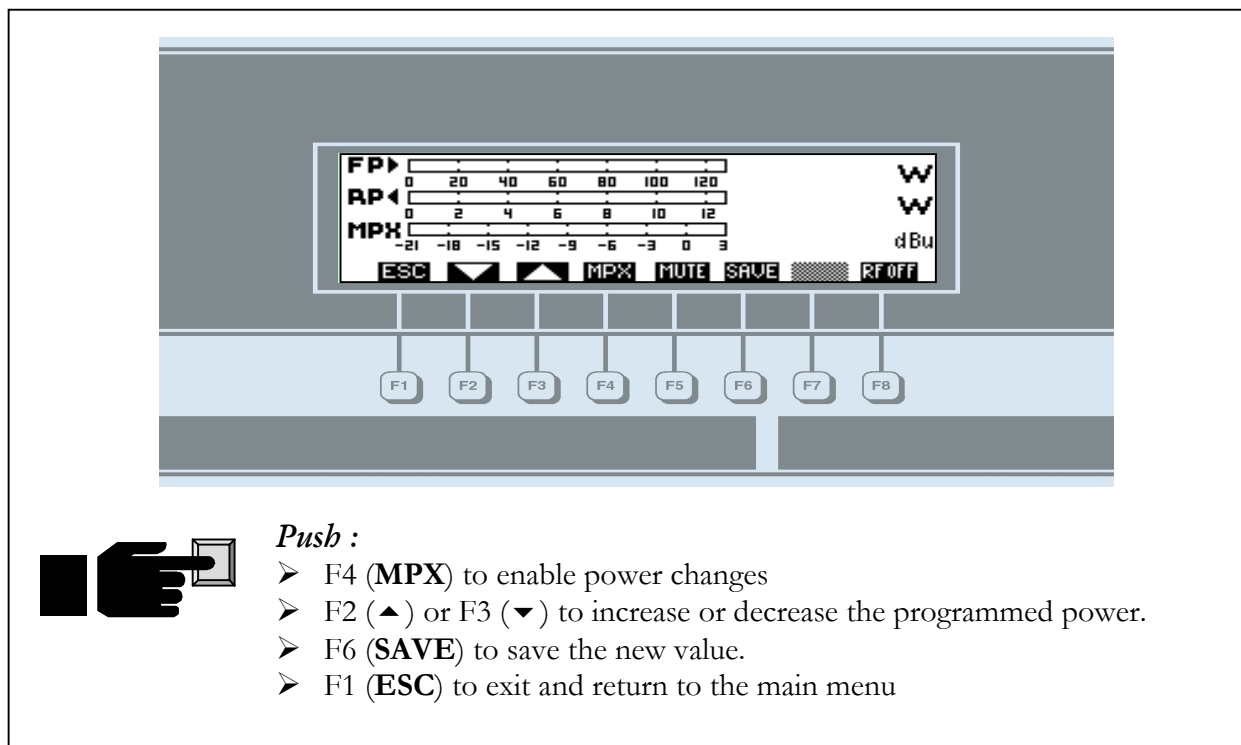
Mono version

The diagram shows a control panel with a monochrome LCD display. The display is divided into three horizontal sections: 'FP' (0 to 120), 'RP' (0 to 12), and 'MPX' (-21 to 3). Below the display are eight function keys labeled F1 through F8. F1 is labeled 'ESC', F2 has an up arrow, F3 has a down arrow, F4 is labeled 'MPX', F5 is labeled 'MUTE', F6 is labeled 'SAVE', F7 has a grid icon, and F8 is labeled 'RFOFF'. A hand icon points to the F4 key.

Push :

- F4 (**MPX**) to enable power changes
- F2 (**▲**) or F3 (**▼**) to increase or decrease the programmed power.
- F6 (**SAVE**) to save the new value.
- F1 (**ESC**) to exit and return to the main menu

SYS programming

Push:

- F5 (**SYS**) to display the window used for general programming of the Exciter.

Stereo version

Push:

- F3 (**▲**) and F2 (**▼**) to select which function is enabled/disabled
- F4 (**R/S**) to enable or disable the selected function
- F5 (**🔑**) to programme the password.
- F6 (**SAVE**) to save the configuration.
- F1 (**ESC**) to exit and return to the main menu

Mono version

MONO/MPX SETUP

RDS	<input type="checkbox"/>	SCA	<input type="checkbox"/>	LOCKED	<input type="checkbox"/>	MHz	0	10
PASSWORD	<input type="checkbox"/>	PREEMPH.	<input type="checkbox"/>	CLIPPING	<input type="checkbox"/>		-6	8
GAIN-3dB	<input type="checkbox"/>	GAIN-6dB	<input type="checkbox"/>	PREEMPH.	<input type="checkbox"/>		-12	6
				STEREO	<input type="checkbox"/>			4
								2

ESC R/S SAVE MPX FP RP

F1 F2 F3 F4 F5 F6 F7 F8

Push:

- F3 (▲) and F2 (▼) to select which function is enabled/disabled
- F4 (R/S) to enable or disable the selected function
- F5 () to programme the password.
- F6 (SAVE) to save the configuration.
- F1 (ESC) to exit and return to the main menu

RDS Options (quick guide)

Push:

- F4 (RDS) to display the RDS programming window.

This window displays RDS parameters.

Date Zone and Time:

- Real-time readout of the RDS card clock.

Zone PTY,DI,TA,TP,MS,PI

- Selection of radio transmission type (PTY,DI).
- Selection of broadcaster characteristics (PI).
- Activation of information type (TA,TP,MS).

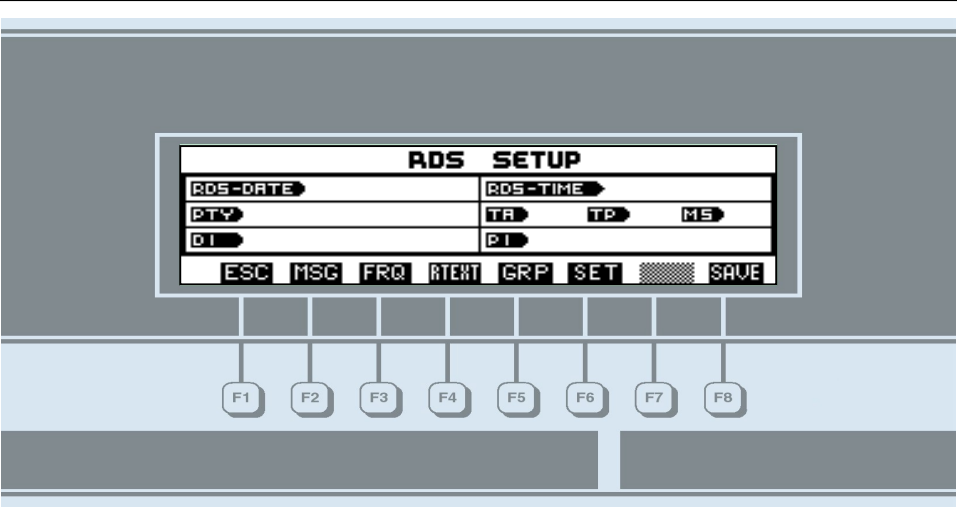

The screenshot shows the 'RDS SETUP' menu on a device. The menu is divided into two columns. The left column contains 'RDS-DATE', 'PTY', and 'DI'. The right column contains 'RDS-TIME', 'TR', 'TP', 'MS', and 'DI'. Below the menu, a row of function keys is shown: F1 (ESC), F2 (MSG), F3 (FRQ), F4 (RTEXT), F5 (GRP), F6 (SET), F7 (SAVE), and F8 (SAVE). Lines connect each function key to its corresponding menu option.

Push:
F6 (**SET**) to enable programming of basic RDS board parameters.

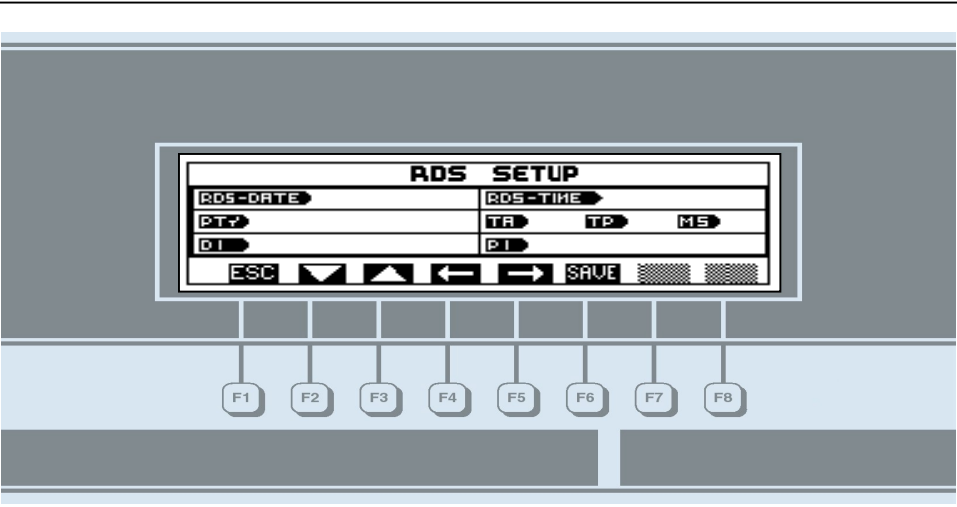

The screenshot shows the 'RDS SETUP' menu with navigation options. The menu structure is the same as in the previous image. Below the menu, a row of function keys is shown: F1 (ESC), F2 (DOWN), F3 (UP), F4 (LEFT), F5 (RIGHT), F6 (SAVE), F7 (SAVE), and F8 (SAVE). Lines connect each function key to its corresponding menu option.

Push:

- F5 (→) and F4 (←) to select the data to be modified.
- F3 (▲) and F2 (▼) to select the option corresponding to the data selected.
- F6 (**SAVE**) to save changes made.
- F1 (**ESC**) to exit and return to the main RDS menu.

RDS RADIO TEXT MESSAGE

Push:

- F4 (**RTEXT**) to enable programming of basic RDS board parameters.

Window for the display and modification of a RADIO 'TEST' message.

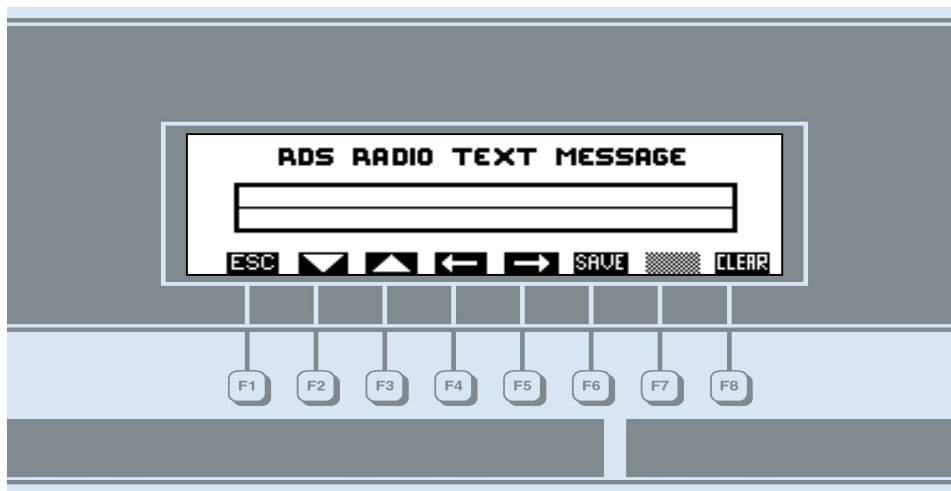

This window displays the RDS test message.

DATA Zone:

- 64 fields comprising 1 character.

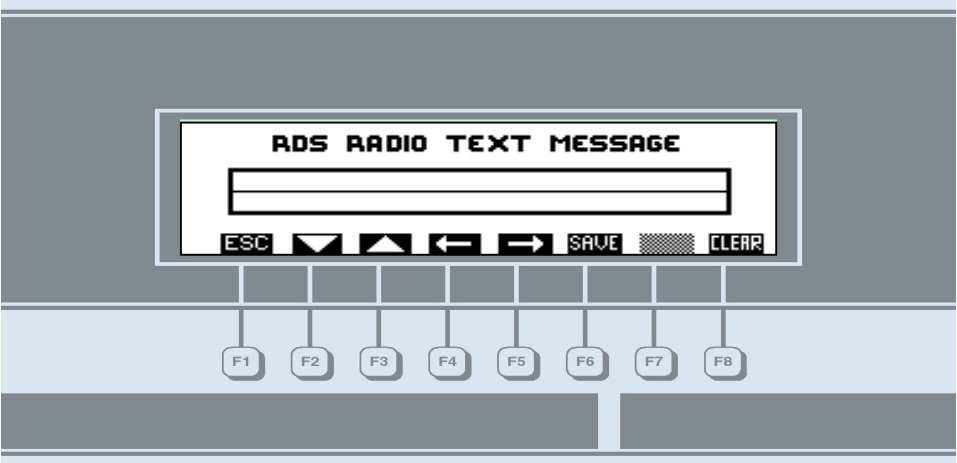

Press:

- F5 (→) and F4 to move the cursor.
- F3 (▲) and F2 (▼) to select the letter to insert.
- F6 (**SAVE**)
- F8 (**CLEAR**) to delete the whole message.
- F1 (**ESC**) to exit and return to the main menu. (If not pressed, **SAVE** retains the previous message).

RDS MESSAGES

RDS SETUP

RDS-DATE	RDS-TIME
PTY	TR TP MS
DI	

ESC MSG FRQ ATENT GRP SET SAVE

F1 F2 F3 F4 F5 F6 F7 F8

Push:

- F2 (MSG) to enable programming of RDS messages.

RDS Message Number 01 [TIMED]

START[01:00]	STOP[10:00]	-00
ELENOS -01	-00	-00
-00	-00	-00
-00	-00	-00
-00	-00	-00
-00	-00	-00
-00	-00	-00

ESC [DOWN] [UP] [LEFT] [RIGHT] SAVE PREV NEXT

F1 F2 F3 F4 F5 F6 F7 F8

This window displays 1 of the 8 RDS messages.

Control Field:

- Status display (Disable, Timed, Scroll).
- START and STOP time display.

DATA Zone:

- 16 fields comprising 8 characters and the display time in seconds.

Deviation Measurements

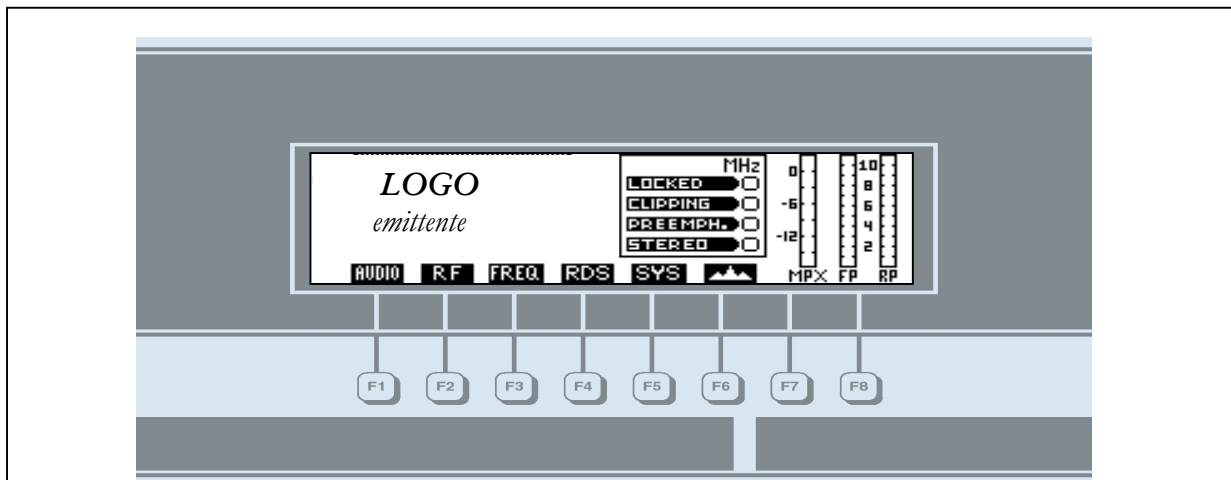

Push:

- F6 () to display the general Exciter programming window.

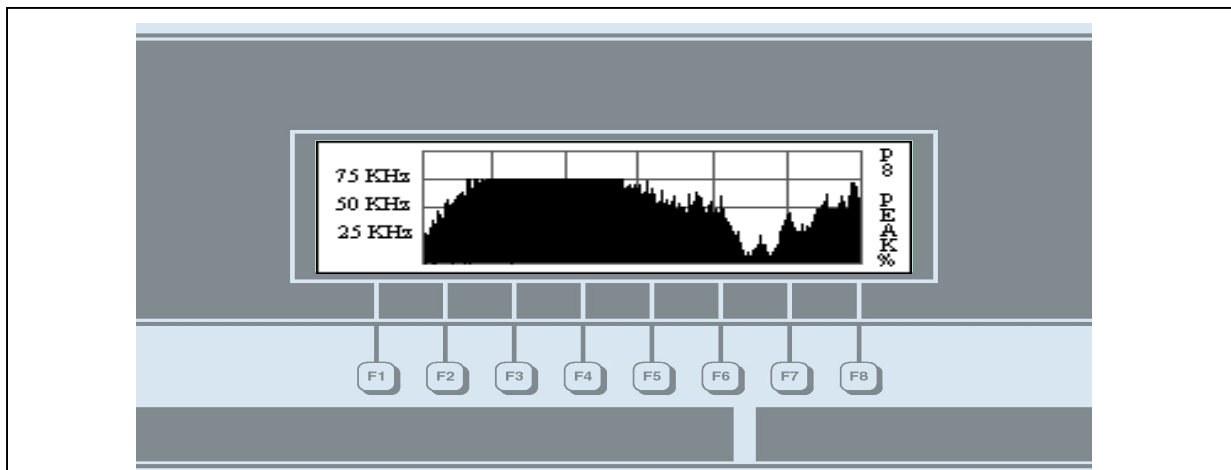

Push:

- F1 (**ESC**) to return to the main menu.
- F8 (**PEAK%**) to display percentage modulation.

This window displays the modulation (MPX) in time (absolute value).

The graph allows a period of several minutes of transmission to be displayed, showing modulation level. To facilitate readings, the grid highlights the 25, 50 and 75 KHz levels.

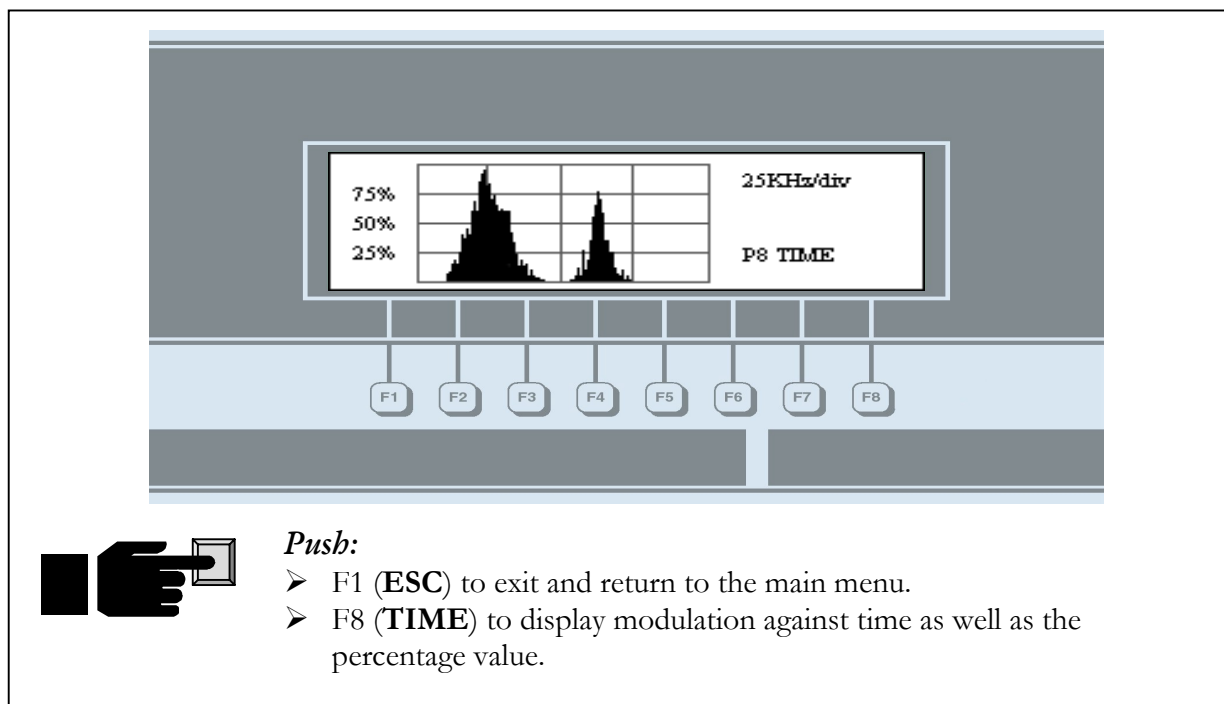

This window displays modulation (MPX) as a percentage.

The graph allows assessment of which values of modulation have the greatest values and thus the percentage by which the 75 KHz modulation level is exceeded.

- Y AXIS: The grid highlights 0%, 25%, 50%, 75%, 100% values.

- X AXIS: The grid highlights modulation values of 0,25,50,75,100 KHz

13 – MAINTENANCE

General maintenance rules

Ensure that power has been removed from the unit before attempting any operation.

Ensure that the Exciter is connected to an effective earthing system.

First remove the top panel and take care not to touch the power supply capacitors: they may still be charged.

Use insulated tools to perform any maintenance and/or calibration procedure.

General maintenance

After installation, the ETG 150 Exciter requires a check every 6 months to ensure correct functioning of the fan and the basic parameters shown on the display: SWR, output power, frequency deviation.

It is necessary to change the ventilation fan periodically and to clean traces of dust from the surfaces of the circuits using a brush or an air line at moderate pressure (< 5 atm).

The time between maintenance will depend on the environmental conditions in which the exciter is operating, in any case it is advisable to:

CHANGE THE FAN EVERY 2 YEARS

CHANGE THE RELAYS EVERY 10 YEARS

14 – RDS CARD (OPTIONAL)

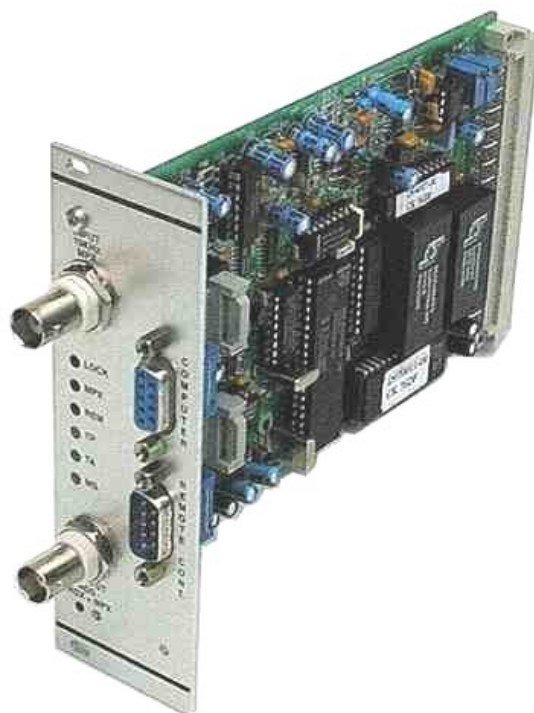

INTRODUCTION

For some years now, it has been widely recognised that the quality and reliability of existing radio services, let alone the implementation of new ones, can be greatly enhanced by transmitting packets of data of various types, in addition to the radio signal. This need has been recognised internationally to the point where dedicated study groups have been formed with the job of identifying the various requirements and defining a transmission standard better suited to the needs of the sector. This group has specified the RADIO DATA SYSTEM which has become today the most widespread data transmission system in the world of radio.

The ETG 150's optional RDS card allows, alongside the radio signal, a data channel to be transmitted, as specified by the document entitled "Specification of the radio data system (RDS)", published by the European Committee for Electrotechnical Standardisation (CENELEC) Ref No. EN50067:1990.

RDS SYSTEM

The RADIO DATA SYSTEM (RDS) has been specified for the transmission of information in mono/stereophonic programmes in the VHF/MF band (87.5-108 MHz). It meets the need to transmit additional data with radio programmes.

- Compatibility with existing mono/stereophonic transmissions
- Absence of adjacent channel interference
- Compatibility with other identification systems already in use

The system, the result of international specialist research, enables transmission of data at a speed of 1187.5 bit/s with phase modulation at 2 levels, 57 KHz carrier and ± 2 KHz band. The transmitted binary signal undergoes differential encoding as a precaution.

The transmission protocol includes 104 bit (87.6 ms) long packets called **GROUPS**, each one of which comprises 4 **BLOCKS** of 26 bits each. Each **BLOCK** comprises 16 bits of information and 10 bits of error protection specifically designed to allow the recovery of words with upto 5bits in error. 16 distinct groups have been specified, some of which have not yet been defined. Each group begins with a **PI** identification code that has the dual purpose of synchronising the receiver and identifying the broadcaster that is transmitting the signal. The **PI** comprises a 4 bit code to identify the country (ITALY code 5), a 4 bit code to define the area of coverage of the transmitted signal (International, National, Sub-National, Regional or Local) and an 8 bit code for the reference number of the programme.

The **GROUP** used to send the **PS** message (displayed on RDS automobile radio receivers) is for the tuning frequencies and the **zero**. Each group 0 contains 2 characters of the message, 2 tuning frequencies, a code to define the type of transmission (Mono, Stereo, Compressed etc.), a bit to indicate if the programme is music or speech, and a code to signal the transmission of traffic information.

Two formats have been defined for the transmission of alternative frequencies:

Method A): each station transmits a unique list of frequencies preceded by the number of frequencies in the list (max **25**);

Method B): each station transmits a unique list of frequencies for each transmitter in use. The list begins with the main frequency followed by the frequencies (max 12) used by contiguous transmitters in the actual coverage area. This method is more efficient when the list of frequencies is long because it allows the autotuning system to examine a smaller number of frequencies and thus speeds up the process of finding new tuning frequencies. If the number of frequencies is low, method A is advised since it requires the transmission of a smaller amount of data.

RDS ENCODER

The RDS encoder comprises a single Euro board with the following features:

- 41612 connector which provides the +5V and +12V supplies.
- BNC for mono or stereophonic signal input.
- BNC MPX and/or MPX + RDS signal output.
- Cannon 9 PIN connector for serial connection to a Personal Computer.
- Cannon 9 PIN connector for connection to a remote keyboard.
- A panel-mounted trimmer for adjustment of the RDS signal level.

- Led indicator, for lock and generation of the RDS carrier (LOCK).
- Led indicator, for synchronisation with the Stereo carrier (STEREO).
- Led indicator, for presence of remote control (REM).
- Led indicator, for TP set (TP).
- Led indicator, for TA set (TA).
- Led indicator, for MS set (MS).



The board is equipped with a serial cable, type DB25 female to DB9 male, which may be changed for a cable type DB9 female to DB9 male (see diagram below), and a 3.5" floppy disc with a programme for setting up the RDS configuration.

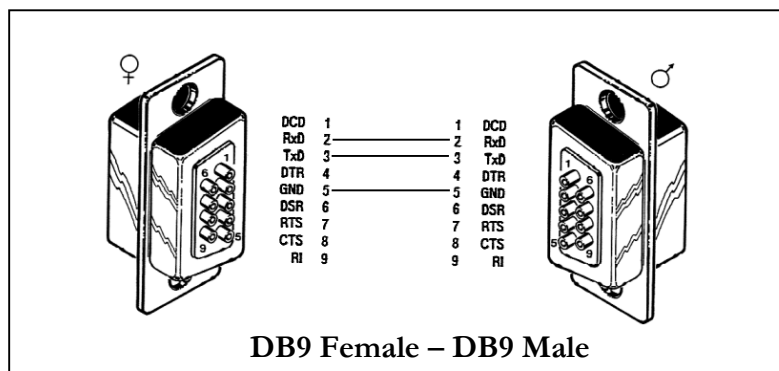
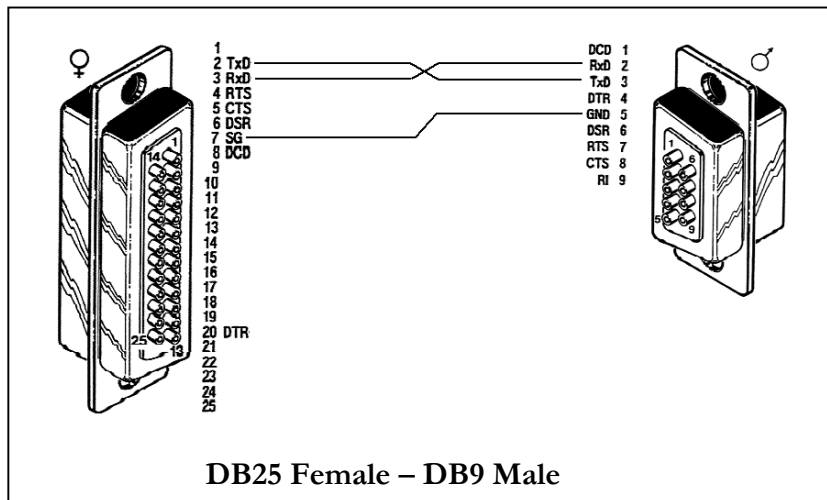

The board includes a microcontroller that generates the RDS message.

The features supported by the encoder are programmed via a personal computer connected to the serial line that uses a very simple programme. Once programmed, the RDS messages are saved even in the event of power loss.

A Timer-Calendar on the board also maintains date and time even in the event of a power loss.

The RDS carrier is internally generated via a quartz-crystal oscillator, but if a 19 KHz carrier is present in the MPX1 IN input signal, which conforms to the specification for amplitude, frequency and stability, the encoder will lock to the external frequency and generate the 57 KHz in sync with it (green led illuminated). Thanks to the microcontroller, the encoder can modify, in real-time, the transmitted message, thus making the system extremely flexible and adaptable to the needs of various users.

The software allows programming of a set of 8 distinct PS messages, each comprising 16 words of 16 characters and a maximum of 16 lists of alternative frequencies; these are not limitations of the system, but rather limits recommended by user groups. The set of messages can be put on-air automatically at any hour of the day.

Programming of messages is very straightforward and quick; it is possible to programme the entire message in one minute. No particular technical knowledge is required of the user.

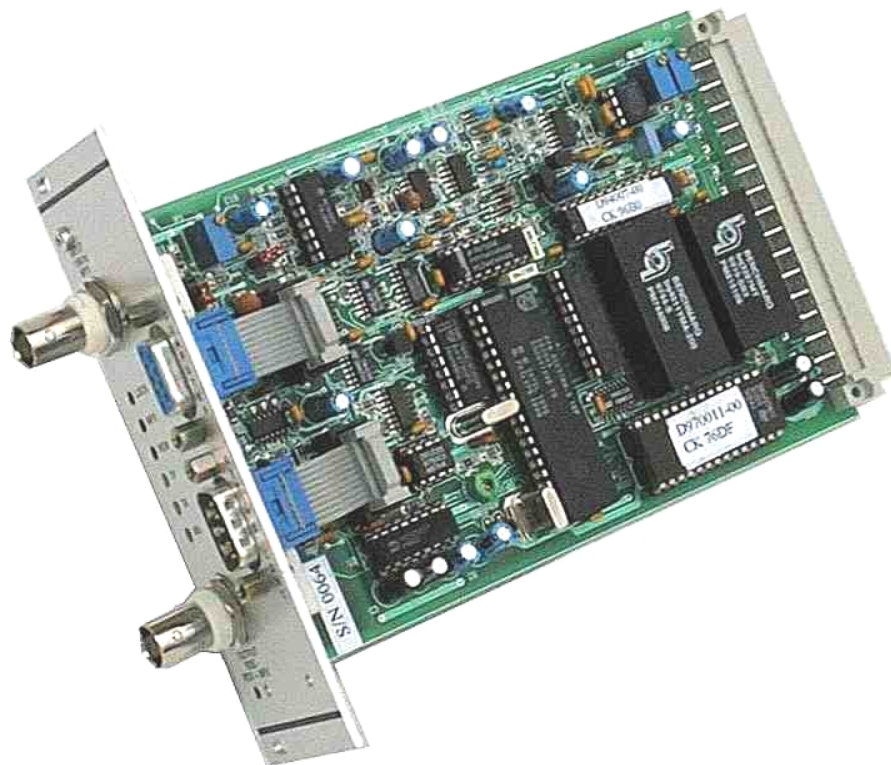

ENCODER PROGRAMMING

Each encoder comes equipped with a 3.5" disc containing software for programming via an IBM compatible Personal Computer.

Once installed, the programme is operational; only the PC need be connected to the encoder and switched on for programming to begin.

At start-up, a screen appears which requests which serial port, COM1 or COM2, is to be used for programming; a second screen subsequently appears, "Baud Rate Selection" which requests the speed of the serial link in terms of baud; **select the 2400 default value.**



Warning:

In the event that the incorrect serial port or baud rate has been selected, the following message appears:



This window will appear whenever a serial link error is detected.

!! Warning !!

Whilst using this programme, close any ETG 150 RDS related window.

Once this choice has been made, the PC interrogates the encoder to determine the data with which it has been programmed and if all is working correctly, a screen will be displayed containing three main sections: "PS Messages", "Alternative Frequencies" and "Program Identification".

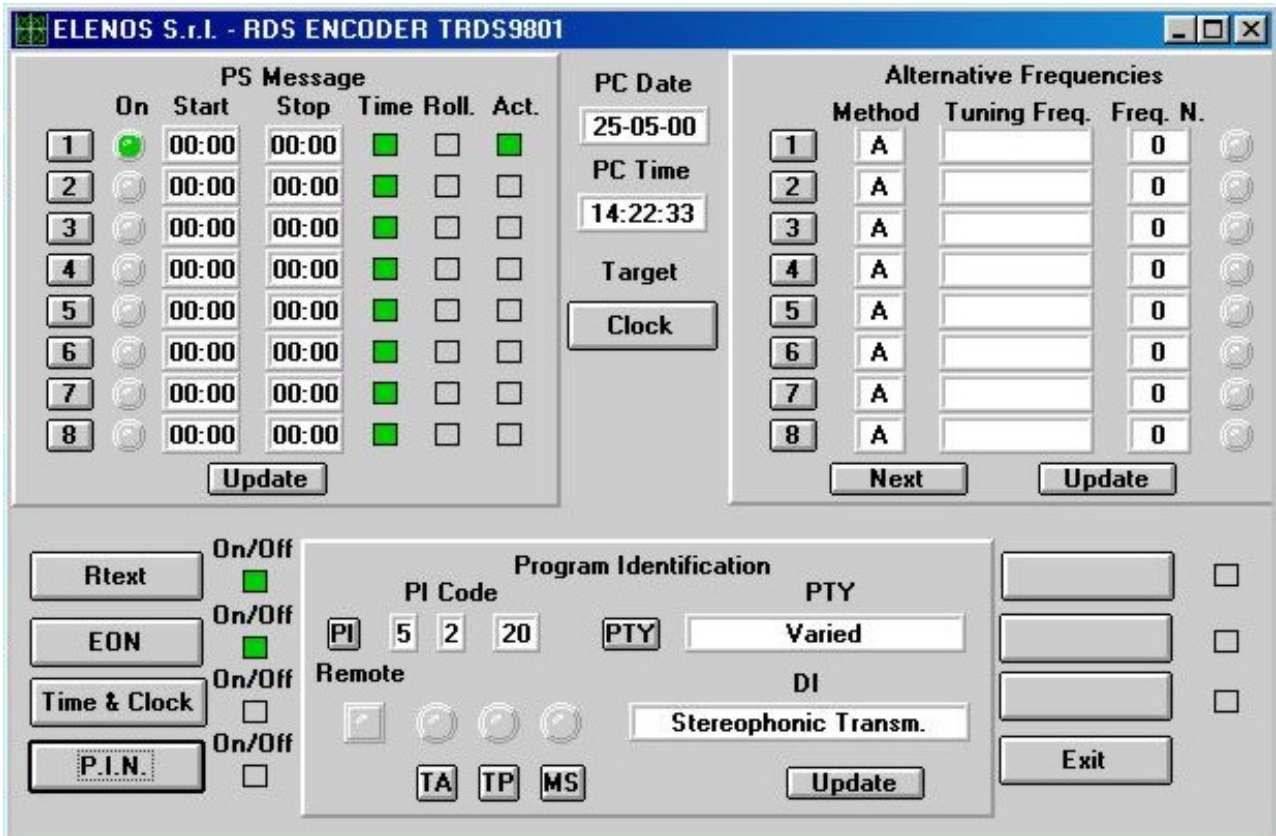

PS MESSAGES

The "PS Messages" section contains 8 sections each comprising the following fields:

1-8 - buttons which activate the windows for modifying the contents of the corresponding PS message.

START – text box for entering the time at which transmission of the corresponding PS message is started. The field can only be modified if the **OR** button is active.

STOP – text box for entering the time at which the transmission of the corresponding PS message is ended. The field can only be modified if the **OR** button is active.

ATT (active) – button to put the corresponding PS message on-air; if green, the message will be put on-air.

OR (time) - button which puts the corresponding message on-air at the time defined; if **OR** and **ATT** are both green, the PS message will be put on-air at the time specified by the **START** and **STOP** fields.

SC (scroll) - button which enables the PS message to scroll by one letter to the right, every second.

ON - indicator which confirms, when green, that the corresponding message is on-air.

The active messages (**ATT** green) which are not timed (**OR** grey) will be transmitted in numerical order, one after the other, during those periods when no timed messages are active. To ensure that the video programming matches that of the encoder, click on the **Update** button.

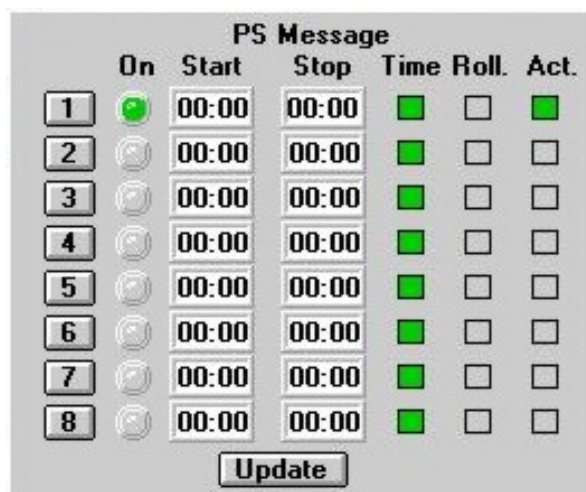

Procedure for programming message "1".

1. Press **OR** (time) so that it turns green (time programming enabled)
2. Click the mouse on the **start** window
3. Delete the previous time (DEL key)
4. Enter the start time, observing the format "XX-XX"
5. Click the mouse on the **Stop** window.
6. Delete the previous time (DEL key)
7. Enter the stop time of the message
8. Press the **1** key (the message entry window will appear)

ENTERING THE PS MESSAGES

Having pressed the button from 1-8 corresponding to the PS message to be programmed, a screen appears with 16 fields for the words that make up the message and the times for which the word will be displayed.

The times, in seconds, can be set between a minimum of 1 second to a maximum of 60 seconds and represent the period that the word is transmitted before passing on to the next word. However, the numerical values have no significance if the message has been programmed to scroll (SC key indicating green in the previous window).

NB: The fields which have had no words inserted will not be transmitted, even if the display time has been set to more than 1 second.

Procedure to programme a message

1. Double click on the text box where the word is to be written and enter it.
2. Set the display time of the word by using the up/down arrows below the text box.
3. Repeat 1 and 2 for all the other words to be entered.
4. Press the **UPDATE** button to save the message and exit the window.

Alternatively press the **EXIT** key to exit the window without saving the message.

From the main window:

5. Press the **ATT** key (message activation)
6. Subsequently press the **UPDATE** key to update the system (the ON indicator will light green to indicate that the message has been activated).
7. At this point it is possible to enter other messages (upto 8) following the same procedure.

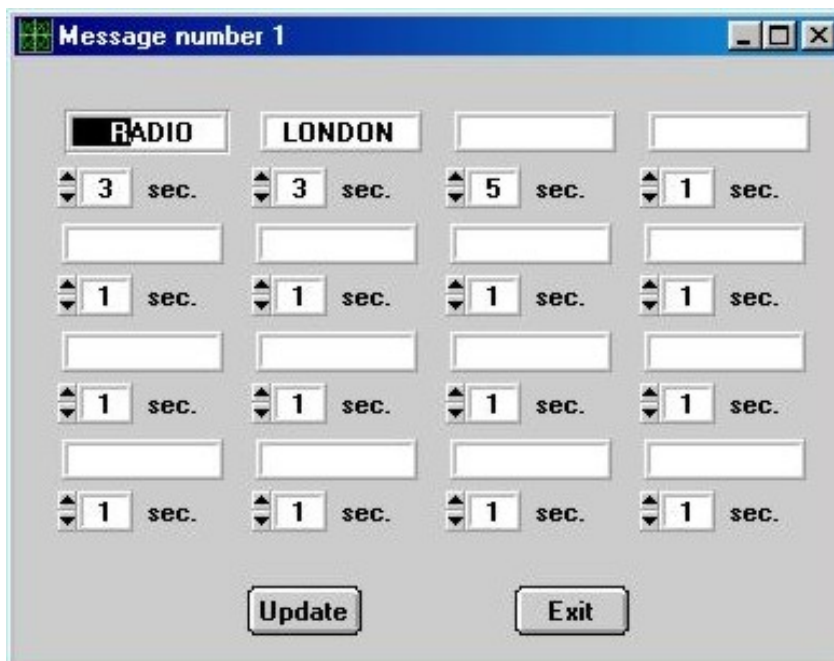

ALTERNATIVE FREQUENCIES

The alternative frequency screen allows 16 lists of unique frequencies to be programmed, each one in method A or B. The screen displays 8 lists at a time and indicates for each one the method (A or B) selected, the main frequency, which is defined only in mode B, and the number of contained frequencies in the list. A list can be accessed by clicking on the corresponding button; the screen will display the mode and the list of possible frequencies on the left and the frequencies contained in the list on the right. Double-click on a frequency contained in the left-hand list to add it to the right-hand list, if not already present. With method A, it is possible to create a list with a maximum of 25 frequencies compared to 12 with method B.

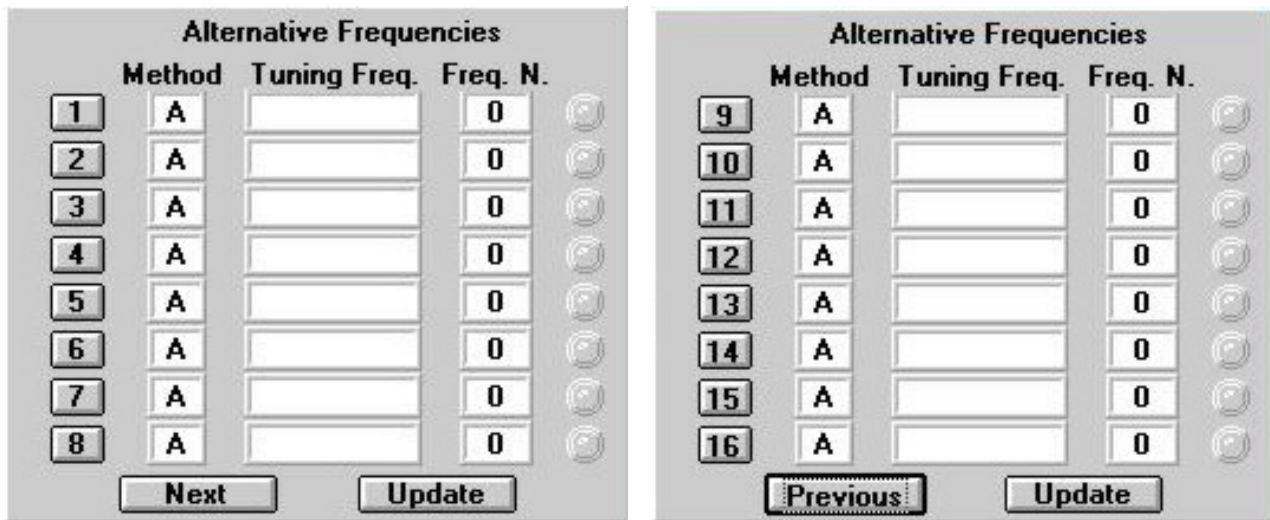

METHOD A/B

The EBU standard allows the set of frequencies to be broadcast that correspond to a network of transmitters. Two modes exist to do this: method A and method B.

Method A allows transmission of one or more lists of frequencies, each with a maximum of 25.

Method B instead allows transmission of as many lists as there are transmitters in the network.

Each list is programmed with the frequency of the transmitter to which it refers and contains all the frequencies of adjacent transmitters.

Each automobile receiver is designed to memorise a certain number of alternative frequencies, from which a new tuning frequency is searched in the event of the current frequency providing a weak signal. The search is much quicker when the set of alternative frequencies is small. When the number of transmitters exceeds 12, it is advisable to use method B so that the radio receiver memorises only the list corresponding to the main frequency to which it is tuned, thus speeding up the re-tuning process.

ENTERING ALTERNATIVE FREQUENCIES

To correctly enter alternative frequencies, follow the instructions in sequence:

1. From the main menu, click on the button corresponding to the list to enter.
2. Select method A or B.
3. Scroll the list of frequencies and double-click with the mouse on the chosen frequency. The data will be inserted in the right-hand list selected. With method B chosen, the first selected frequency corresponds to the main frequency and will appear in the relevant window. To delete any selected frequency, double-click on it with the mouse.
4. Finish entering by clicking on **EXIT**.
5. In the main menu, a green indicator appears to the left of the list which has data entered or changed, to confirm that data has indeed changed. Click "**UPDATE**" to memorise the new data on the RDS card.

At this point, further alternative frequencies may be entered.

Example

Method A

Method B

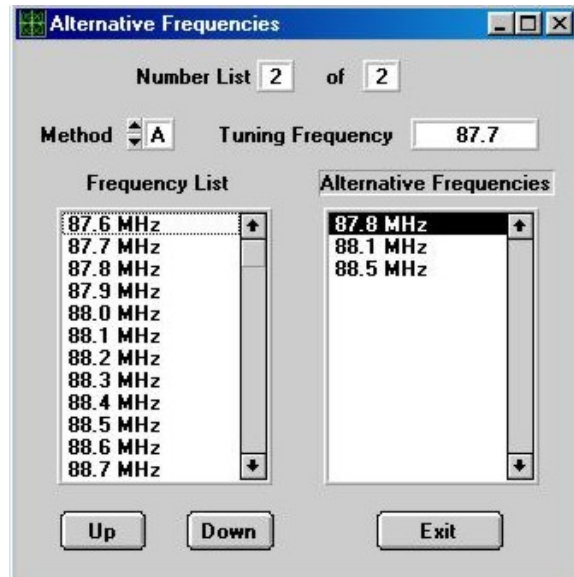
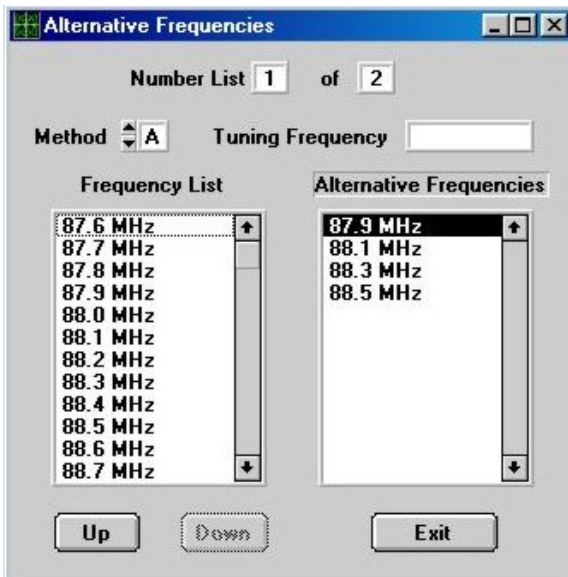

PROGRAM IDENTIFICATION

In this section, various parameters relating to the broadcaster are programmed; Program Identification, Program Type, Decoder Identification, Traffic Announcement, Traffic Program and Music/Speech.

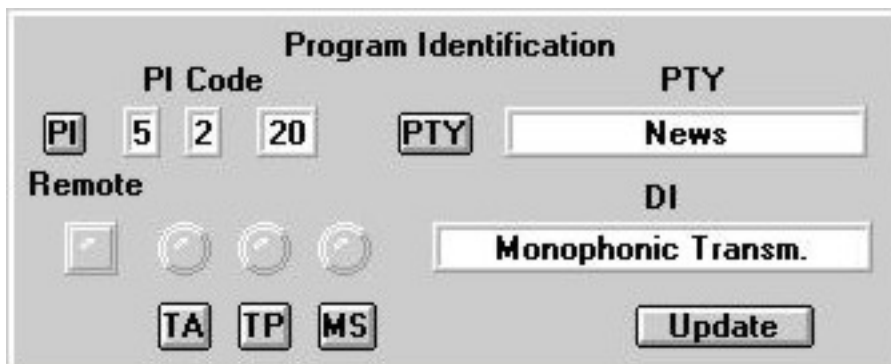

PROGRAM IDENTIFICATION PI

The PI is an identification code comprising three fields; COUNTRY + EMISSION + CODE.
 The COUNTRY is a numerical value from 0 to 15 (0 to F in hexadecimal) which identifies the country to which the broadcaster belongs (Italy is code 5)
 EMISSION is a numerical value from 0 to 15 (0 to F in hexadecimal) which identifies the range of the broadcast signal (local, regional, national, international)
 CODE is a numerical value from 0 to 255 (00 to FF in hexadecimal) which identifies the broadcaster and is defined by an authorised organisation.

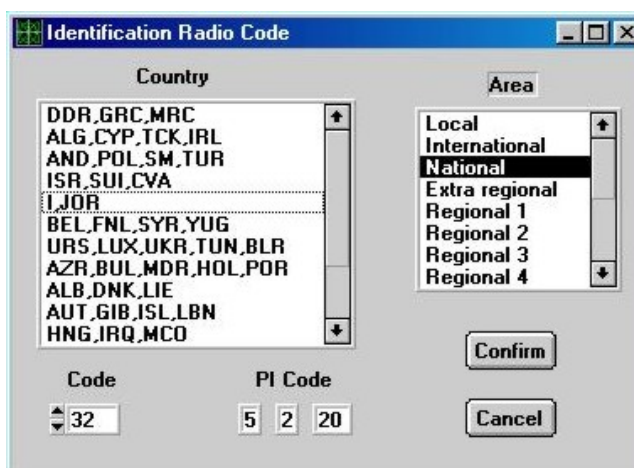

1. To programme PI click the mouse on the corresponding button.
2. Double-clicking on the item required will automatically activate the relevant code.
3. Press the CONFIRM key to confirm the selections.
4. Press CANCEL to exit without saving.

PROGRAM TYPE PTY and DECODER IDENTIFICATION DI

PTY is a code with 32 possible values (0 to 31) which defines the type of transmission being broadcast. DI identifies 16 different operational modes in which the broadcaster can transmit.

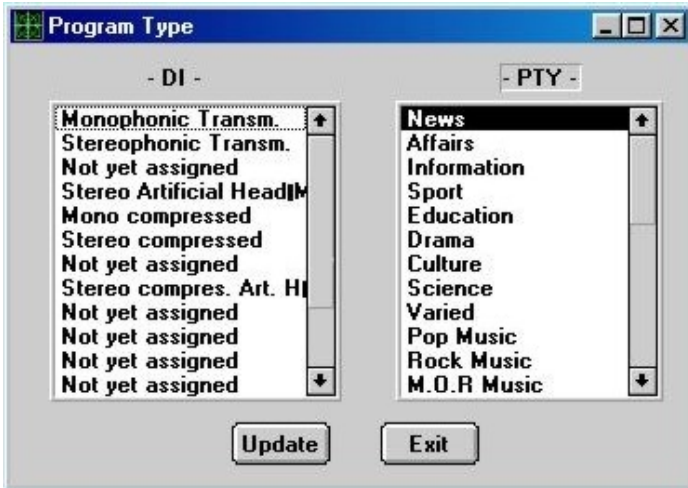

Programming is initiated by clicking on the **PTY** key.

Press **UPDATE** to save the selection

Press **EXIT** to exit without saving.

TA-TP-MS

At any time during the day, the broadcaster can interrupt the programme and transmit traffic news. In order to perform this function, the standard allows flags to be set in order to signal to the automobile radio that this information is being transmitted so that automatic tuning and/or volume control can take place. These flags are labelled **TA**, **TP** and **MS**.

The **TP** flag identifies the transmissions that carry traffic reports.

The **TA** flag identifies the time periods in which the traffic reports are transmitted.

The **MS** flag indicates whether the current transmission is Music or Speech.

These flags can be set by clicking the mouse on the corresponding buttons or via a remote keyboard connected to the appropriate connector on the card. If the remote keyboard is connected, the green “Remote” indicator will light and PC control is inhibited.

If the colour of the **TA**, **TP** and **MS** buttons do not agree with those of the leds, it means that the flags on the screen do not tally with those of the encoder. To synchronise them, press the Update button.

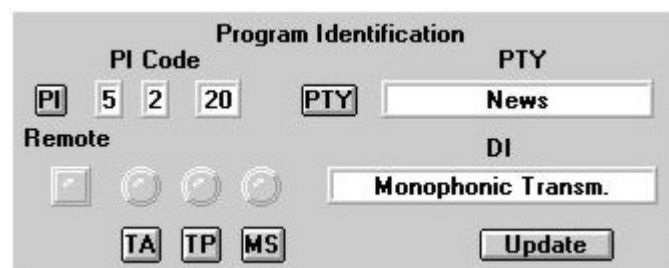

RADIO TEXT

Radio Text is a message with a maximum length of 64 characters, used to check the quality of the signal within the transmission area of the signal. The message, if active, is transmitted indefinitely.

To set the message, click on the RTEXT button with the mouse.

To activate the message, click on the ON/OFF button next to it.

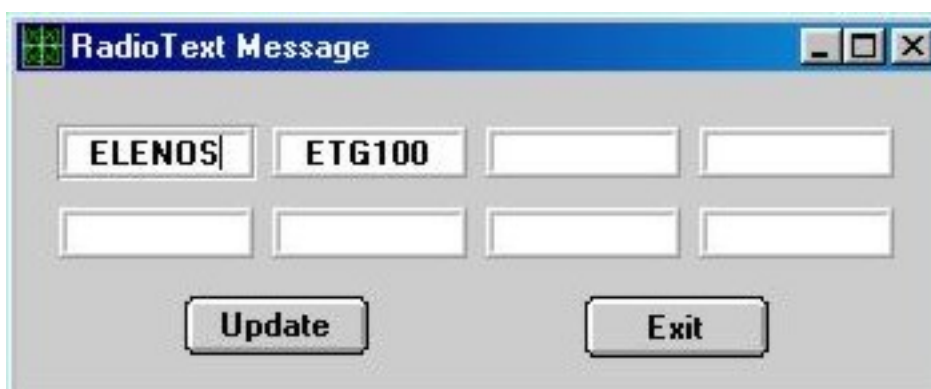
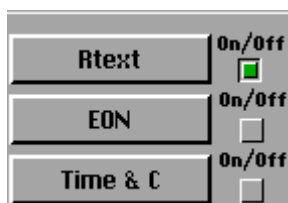

EON Message

The EON (Enhanced Other Network) message is used when a broadcaster has agreements with other networks such that the other network may be automatically tuned into should the current broadcaster's signal be weak or missing, or if there is information of interest to the listener being broadcast by the other network.

The RDS systems allows up to 8 other networks to be programmed. Each broadcast network is a broadcaster in its own right for which the data to be programmed must give it a unique identity and allow all services of common interest between the two broadcasters to be defined.

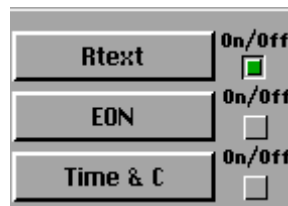

Access to programming this data can be made by clicking on the **EON** button situated on the left side of the main window; the list of the 8 networks that can be programmed follows.

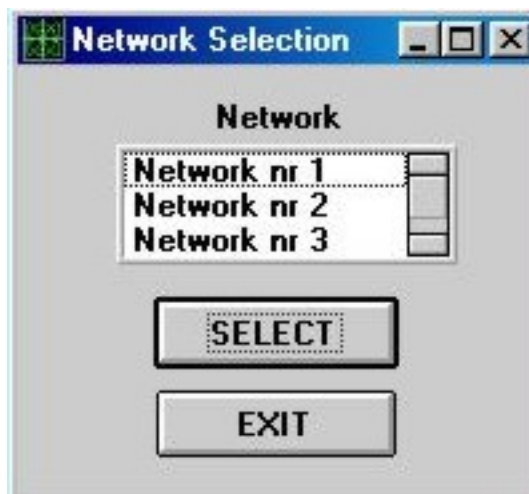

Having selected a network, a screen appears in which all the parameters to be programmed are present, i.e.:

PI-PS-TA-TP-PTY-AF-PIN

PI is the identification code of the other network.

PS is the 8-character message that is displayed on the automobile radio when it is tuned to the other network.

TP indicates that the other network is enabled to transmit traffic reports.

TA indicates that the other network is transmitting traffic reports.

PTY indicates the type of programme being broadcast.

AF indicates the list of alternative frequencies on which the other network is present.

The set-up procedure is analogous to that of the main broadcaster (see above). For each network up to 7 frequencies can be programmed with method A and 4 with method B.

To enable transmission of data programmed on each network, press the **“MESSAGE ACTIVE”** button; if this button is lit green, the programmed data is valid and may be transmitted.

ATTENTION: the active network’s data (with Message Active lit green) is transmitted if the on/off button on the main screen is lit green.

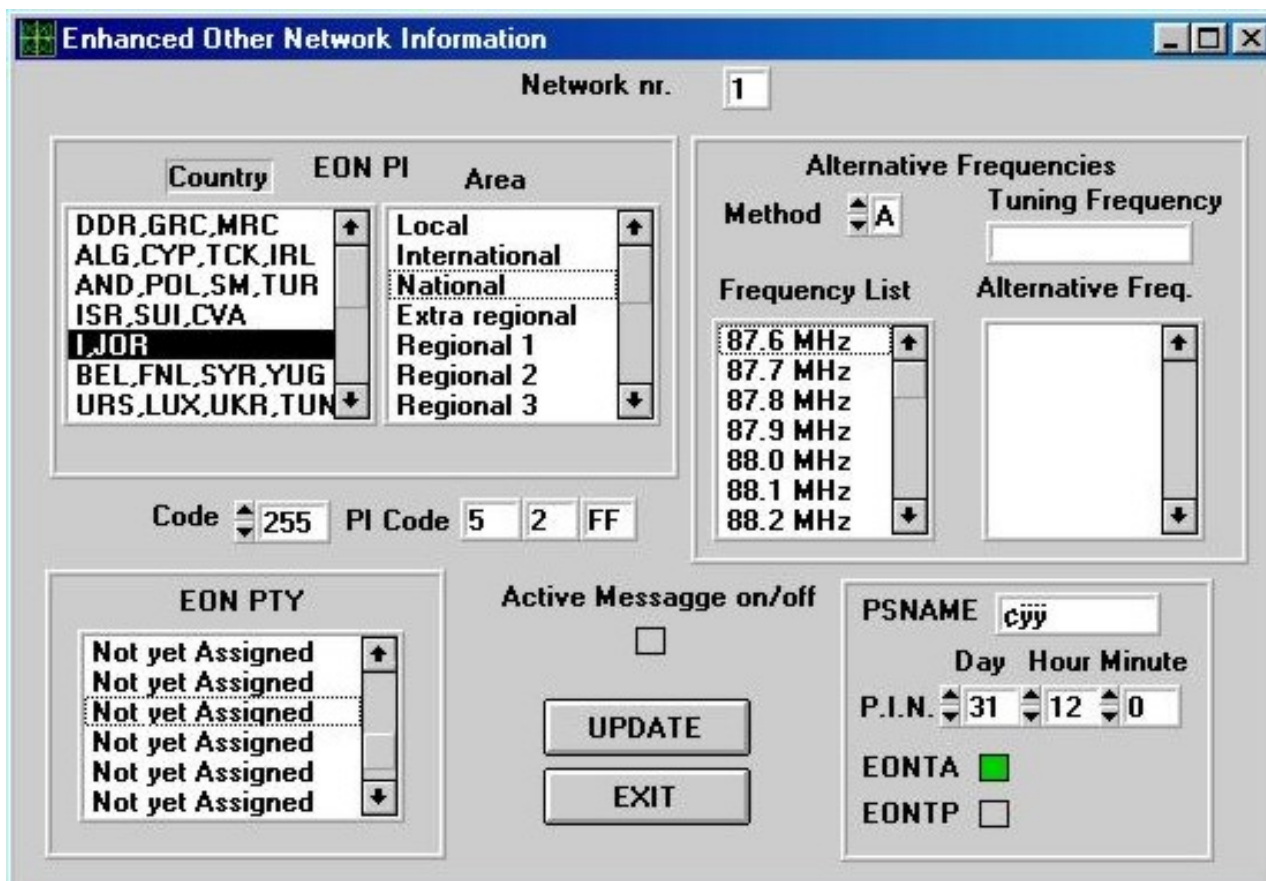

TIME & CLOCK DATA

The RDS encoder has an on-board clock-calendar which provides independent indication of time. The clock-calendar can be read and updated and can be used to synchronise the clocks of any radios that are tuned in. When this message is transmitted, at every change of minute, the encoder sends a data packet containing the date and time based on the Greenwich Meridian. The time difference is in half-hour steps.

To update the clock-calendar to the current date and time:

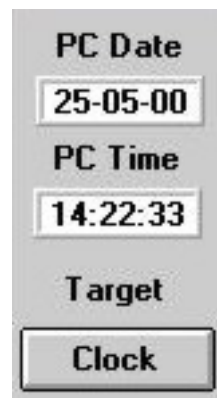

1. Press the **CLOCK** button, or the **TIME & C** buttons
2. Double click on the **TARGET TIME** box and enter the local time for the location in which the signal is being broadcast.
3. Double click the **TARGET DATA** box and enter the date.
4. Select **position relative to Greenwich** (the RDS system is able to update the time as a function of the country in which one is in)
5. Press the **UPDATE** button to transfer the data to the encoder.



If the **EXIT** button is pressed, no changes are made to the clock/calendar.

EXIT



Once the programming is finished, the PC can be disconnected and used for other applications. Clicking the **EXIT** button will terminate the software programming of the encoder.

TECHNICAL DATA

RDS SIGNAL	as specified by CENELEC EN 50067
CODING	differential at 2 levels
MODULATION	DSB with suppressed carrier
FREQUENCY	57 KHz
BAND	+/- 2.4 KHz
MPX INPUT	0/+12 dBm into 600 Ohm
OUTPUT	MPX +RDS
MPX OUTPUT LEVEL	Inp. MPX
RDS OUTPUT LEVEL	20 – 150 mV RMS
OUTPUT IMPEDANCE	100 Ohm
PS MESSAGES	8 with 16 words of 8 characters
ALTERNATIVE FREQUENCY LIST MESSAGE PROGRAMMING	16 with max. 250 frequencies each with IBM compatible PC
CONNECTION	RS 232-C Standard
COMMUNICATION	Full Duplex
SPEED	2400 baud
CONNECTORS	9 Pin Cannon female 9 Pin Cannon male BNC
MESSAGE MANAGEMENT	microcontroller
CONSERVATION OF DATA	10 years
OPERATING TEMPERATURE	0-55 °C
POWER SUPPLY	+12Vdc 100mA, +5Vdc 800mA

Inserting the RDS card

The RDS card is inserted in connector 4 of the ETG 150.

15 – CIRCUIT DIAGRAMS

Power Supply diagram

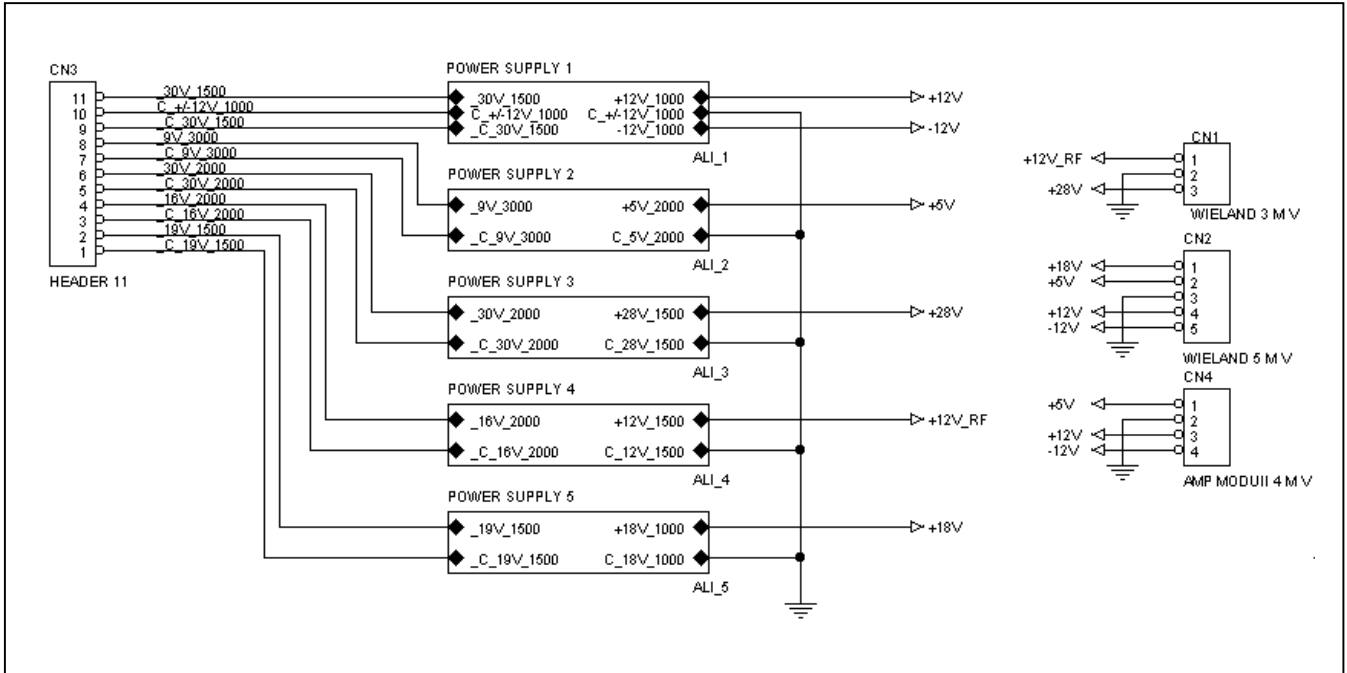

“Power supply 1” Circuit diagram

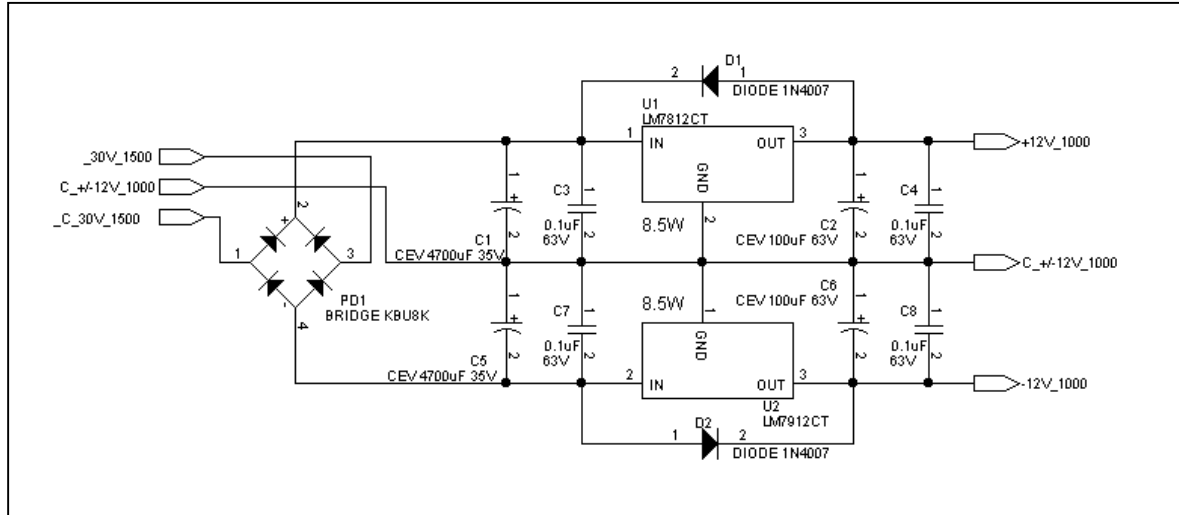

“Power supply 2” Circuit diagram

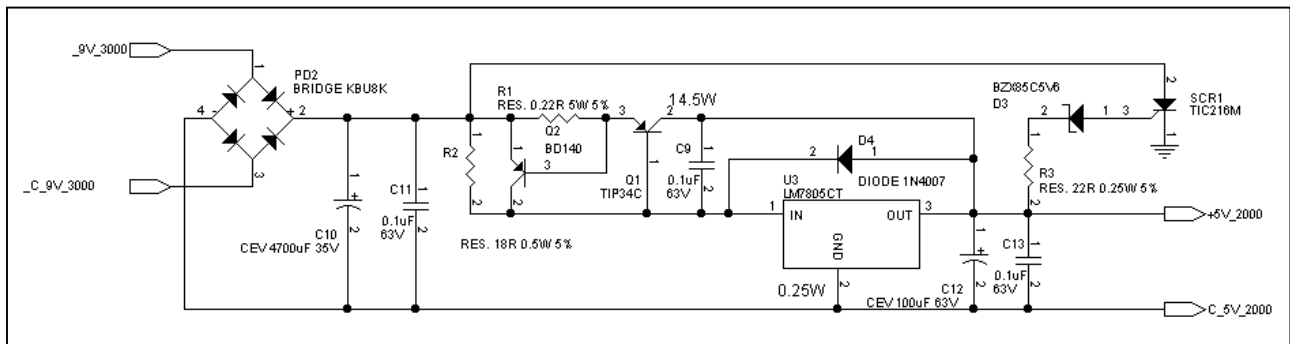

“Power supply 3” Circuit diagram

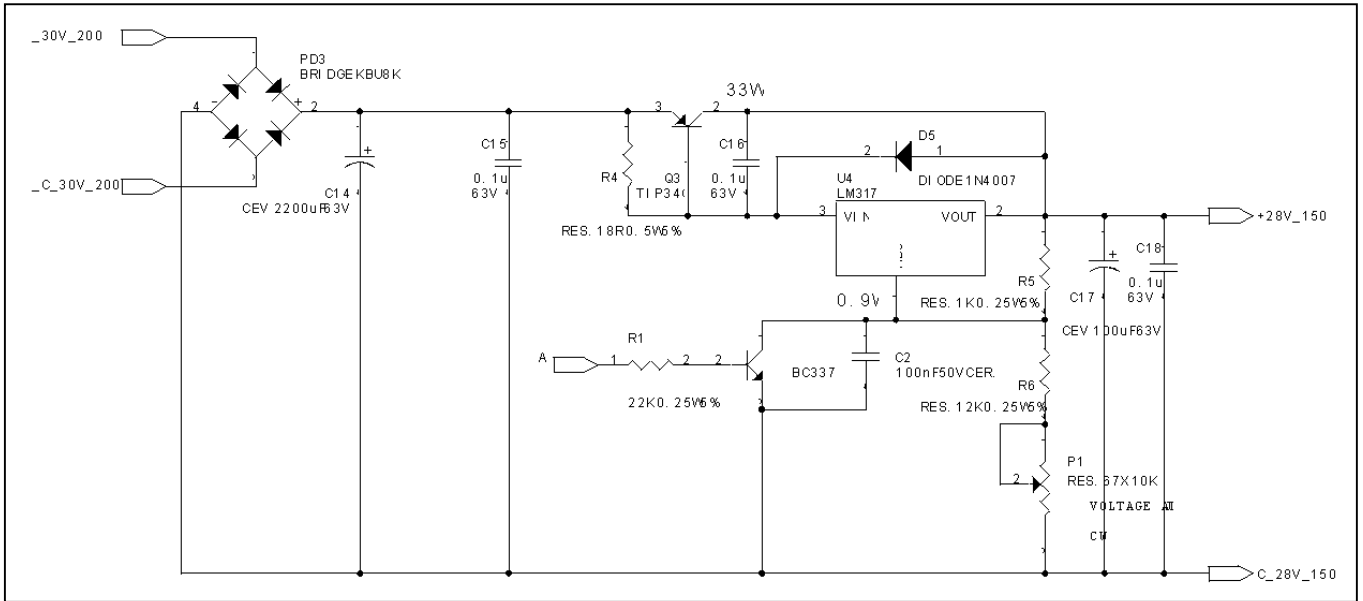

Power supply 4” Circuit diagram

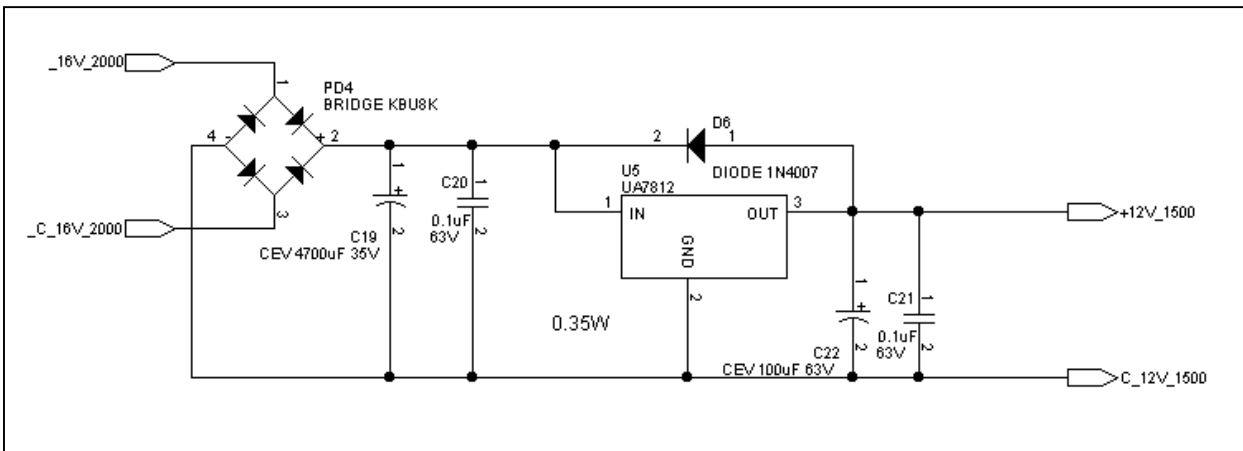

“Power supply 5” Circuit diagram

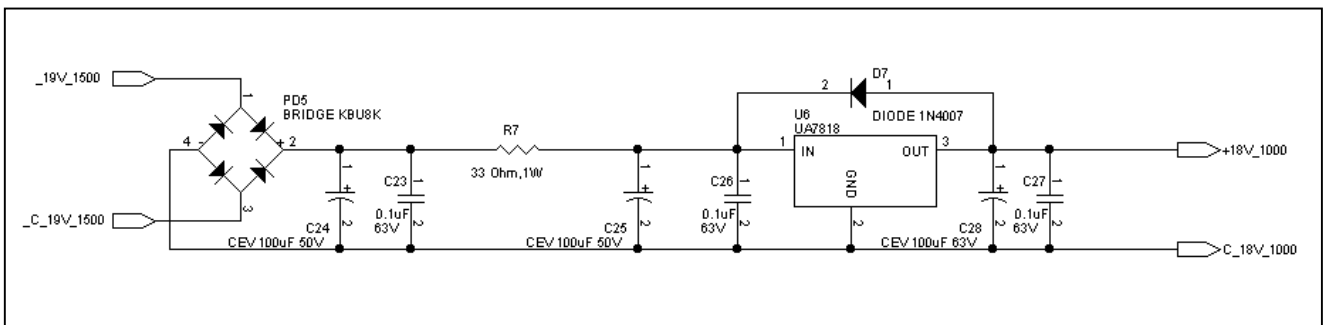

Auxiliary Power Supply assembly drawing (power supply 1-5)

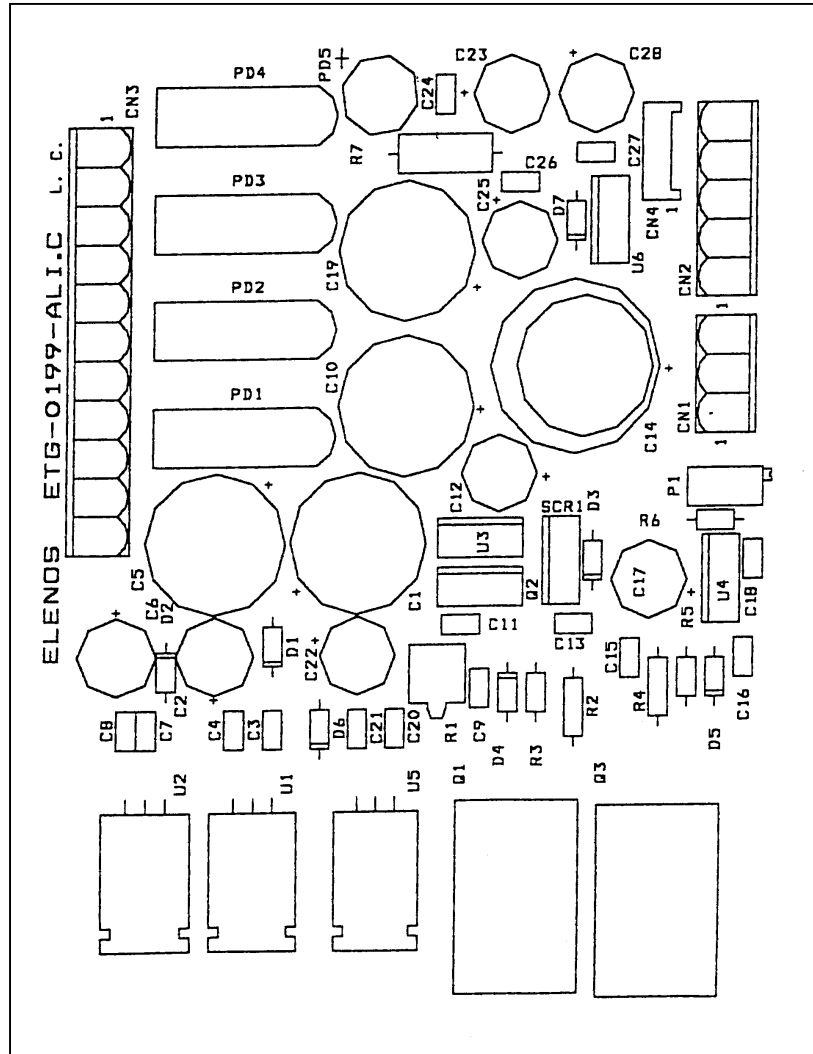

Power Supply circuit diagram

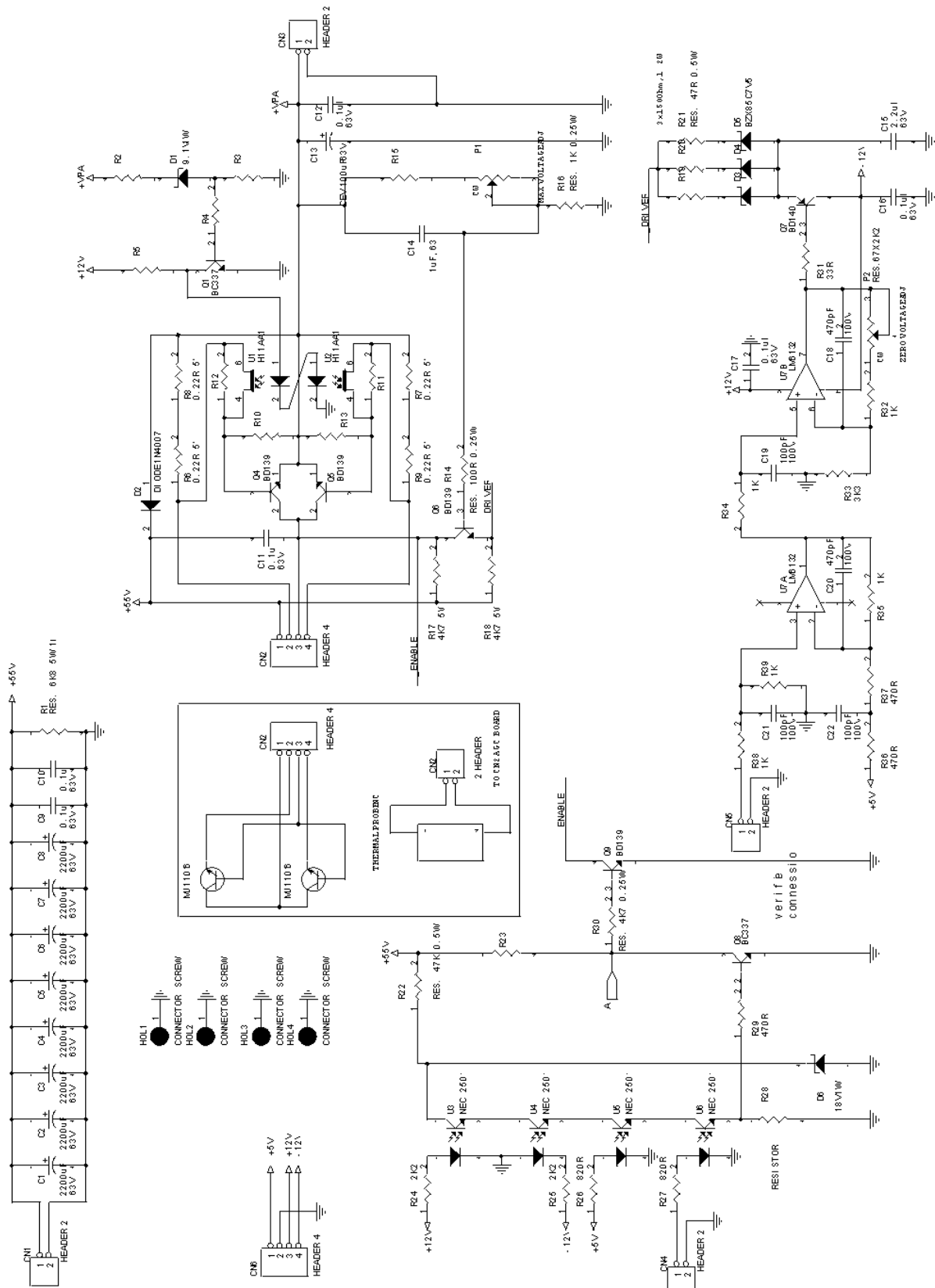

Power Supply assembly drawing

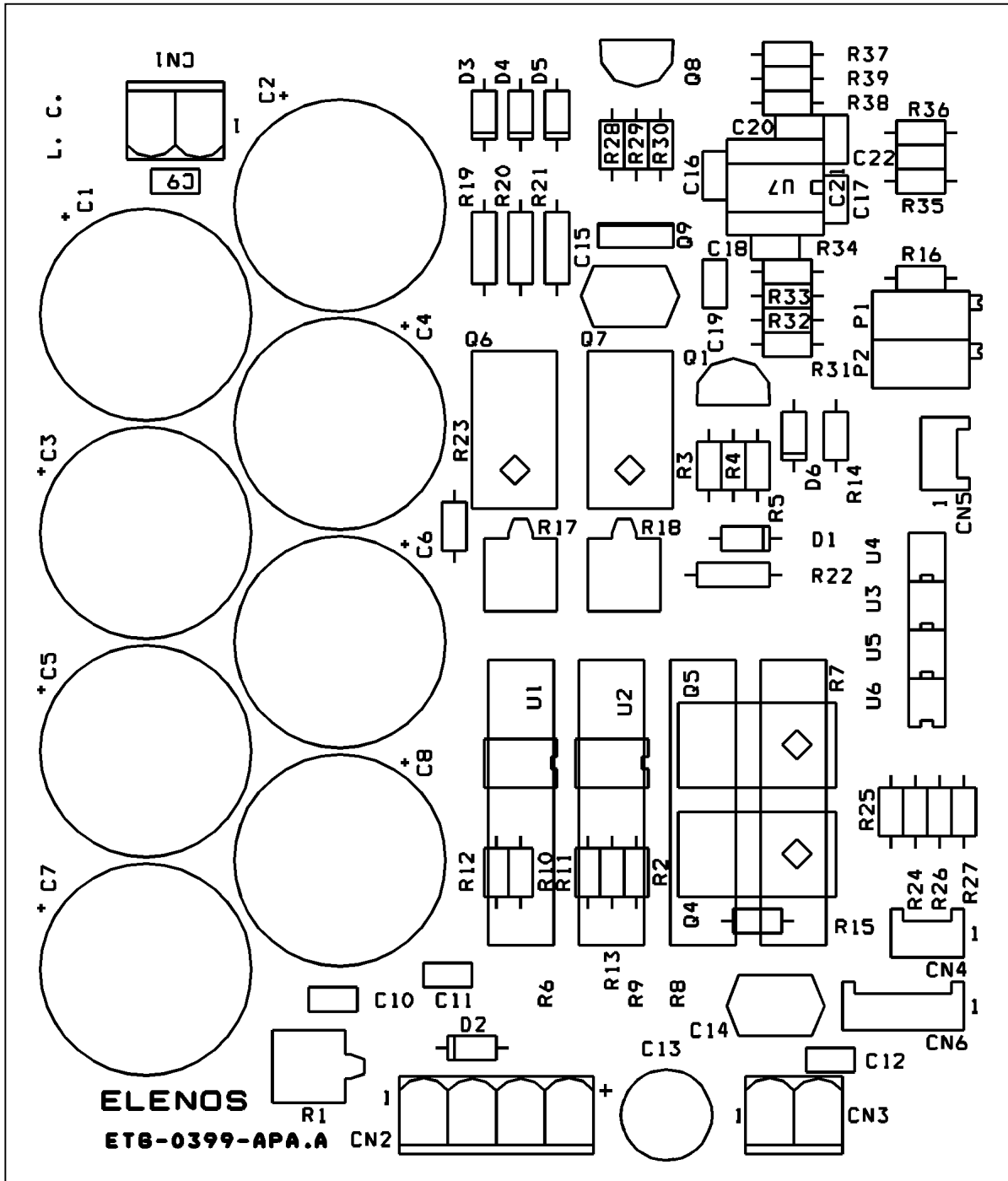

AGC circuit diagram

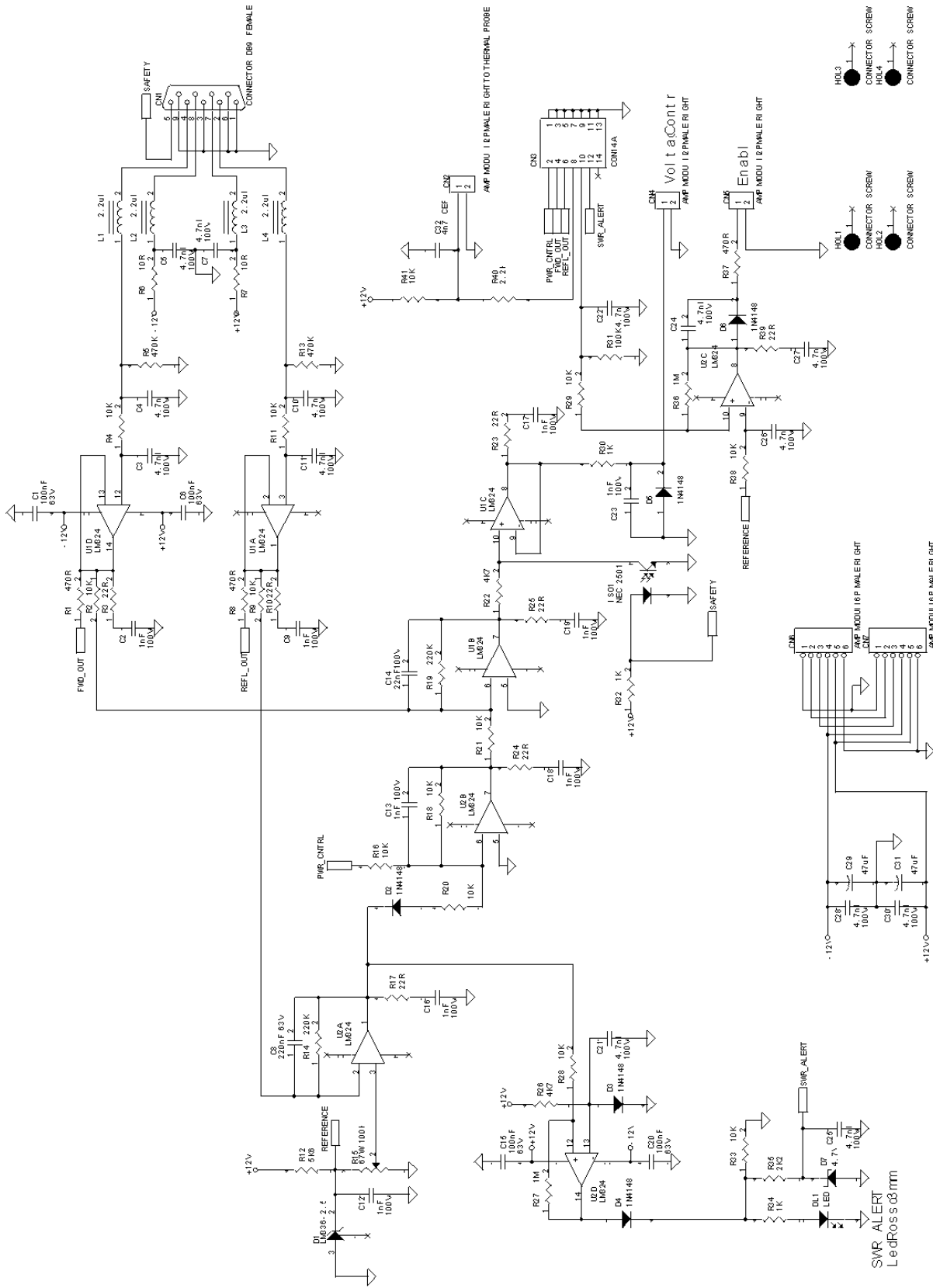

AGC assembly drawing

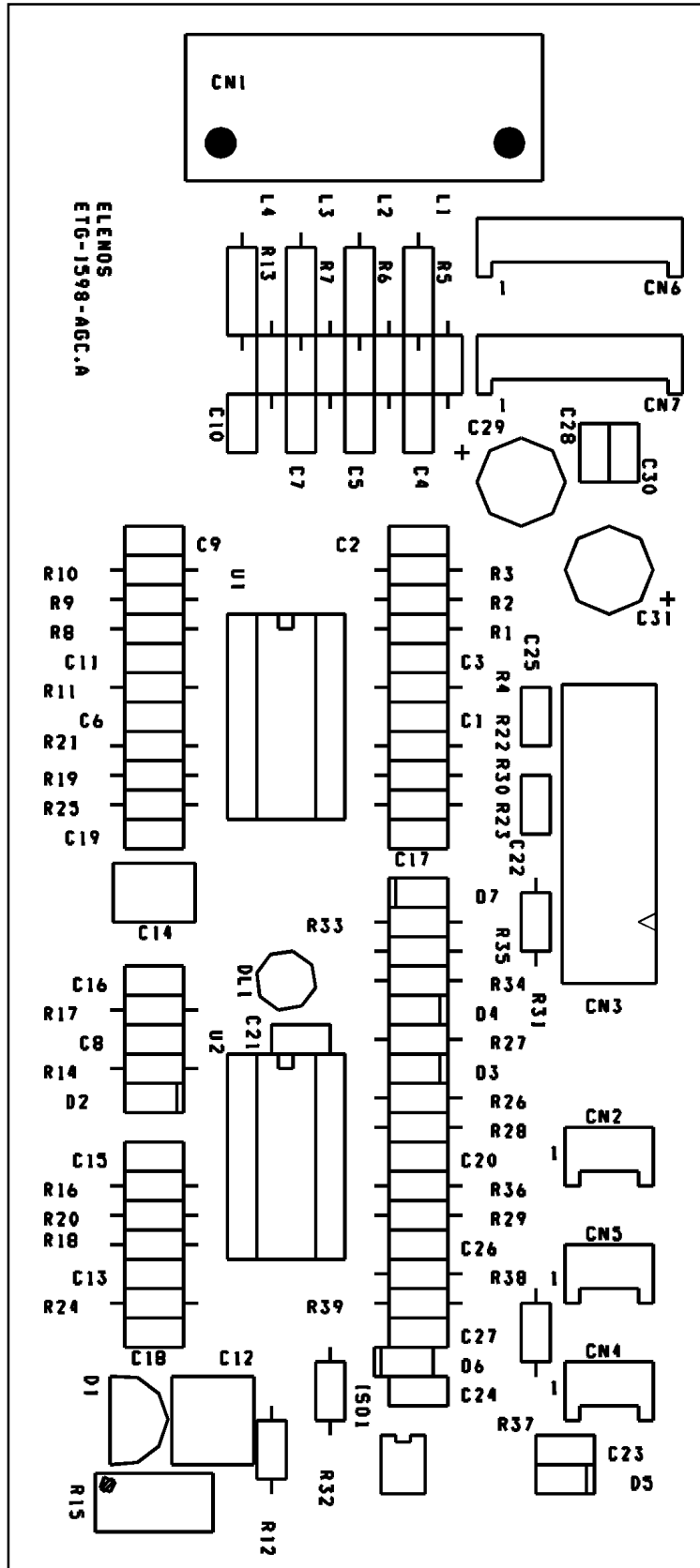

Fuse Board circuit diagram

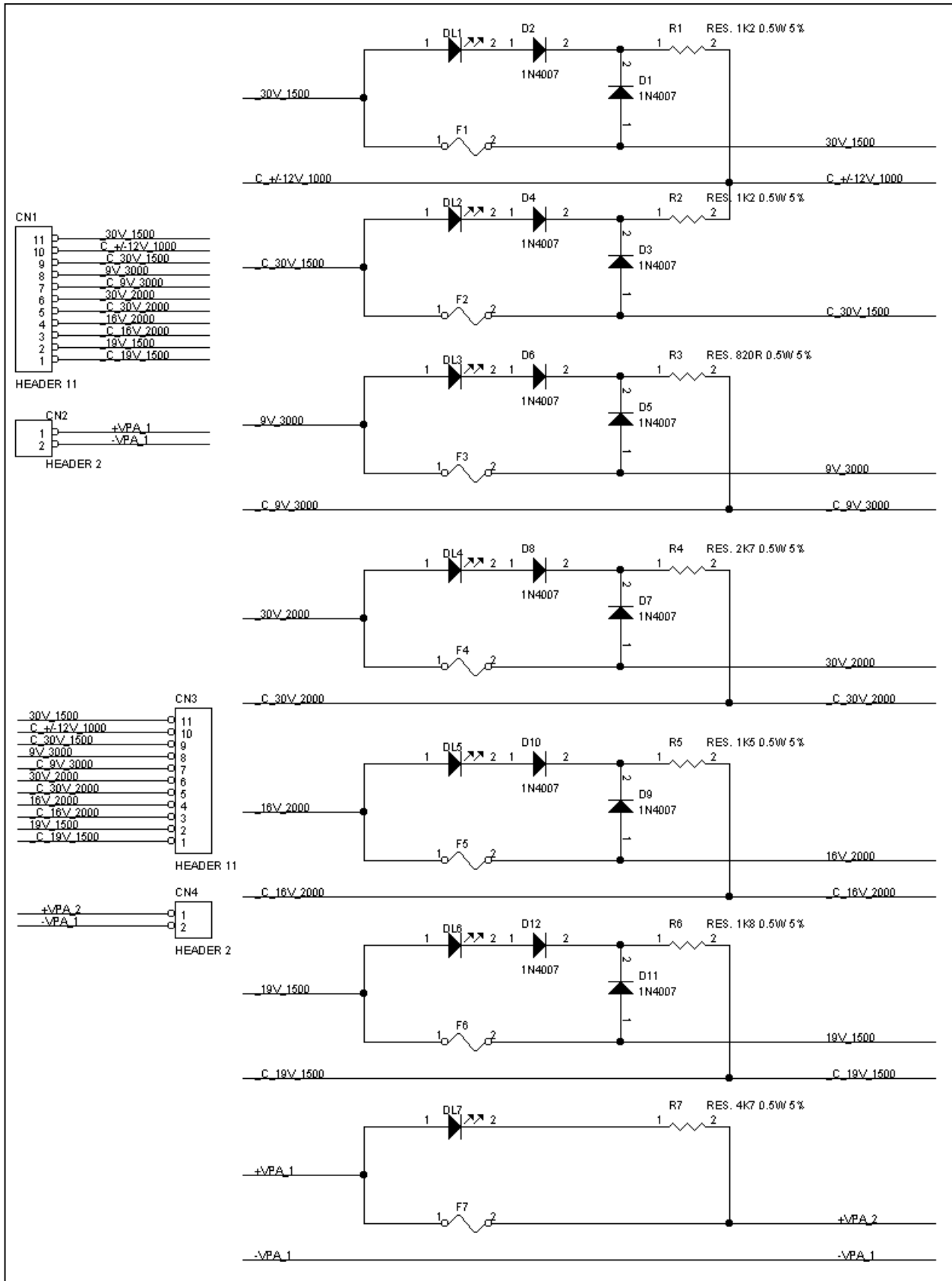

Fuse Board assembly drawing

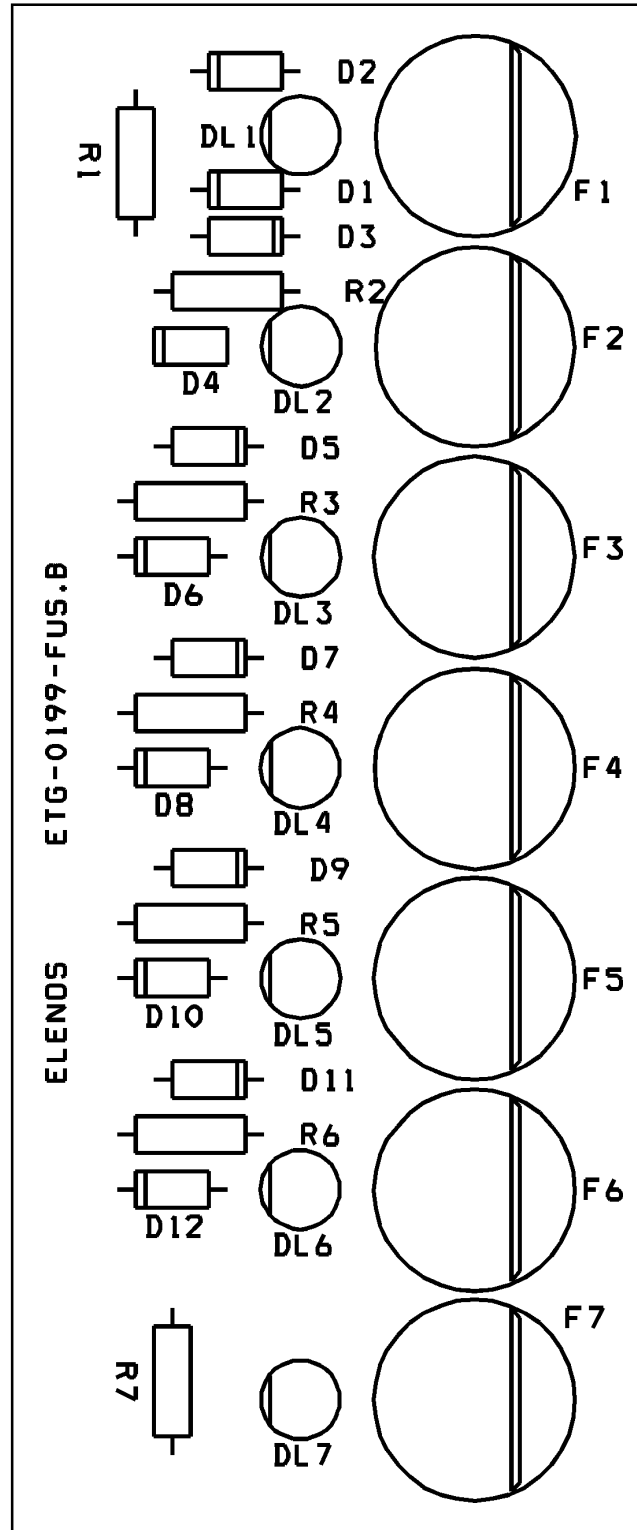

Front Panel circuit diagram

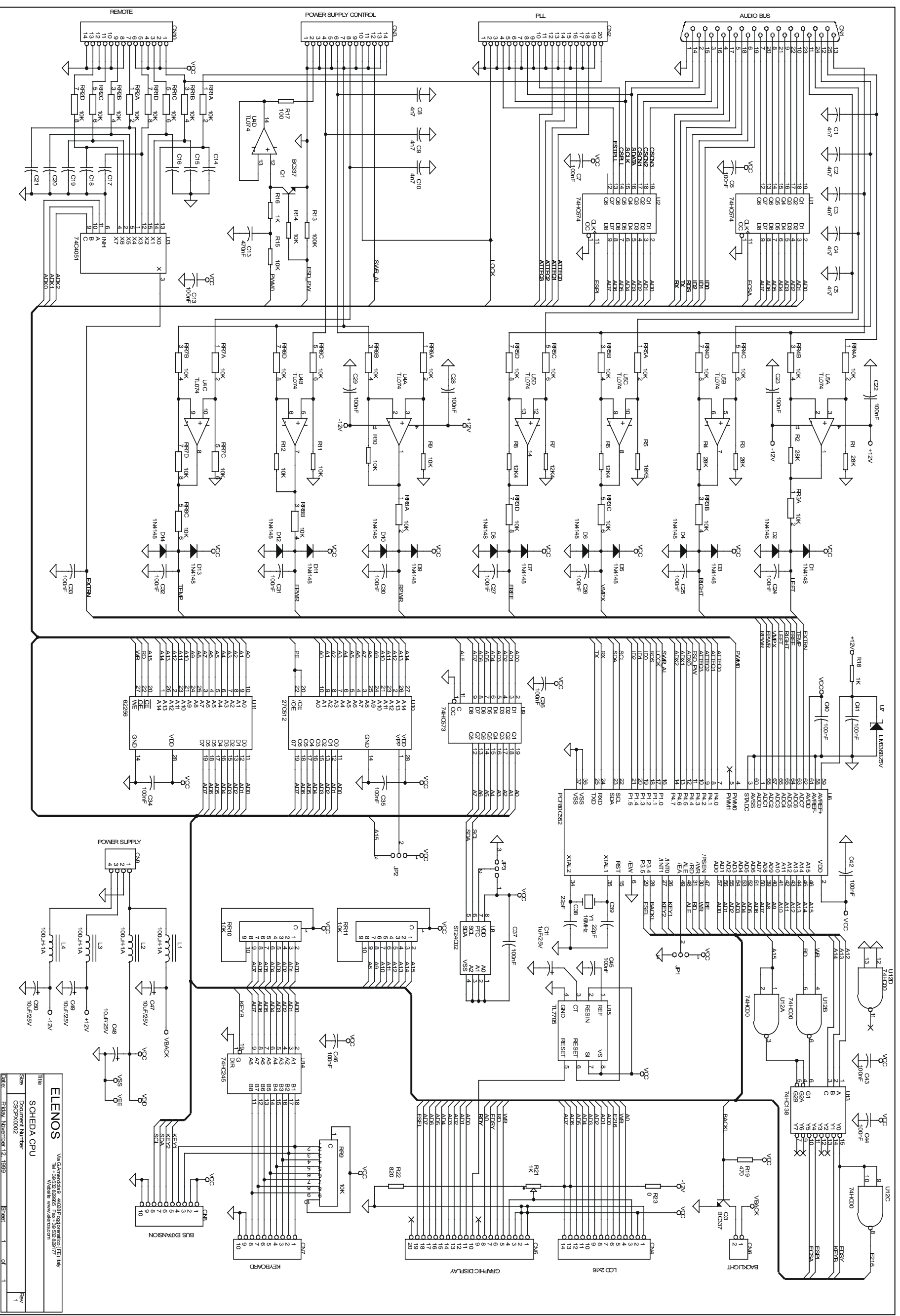

Front panel circuit board assembly drawing

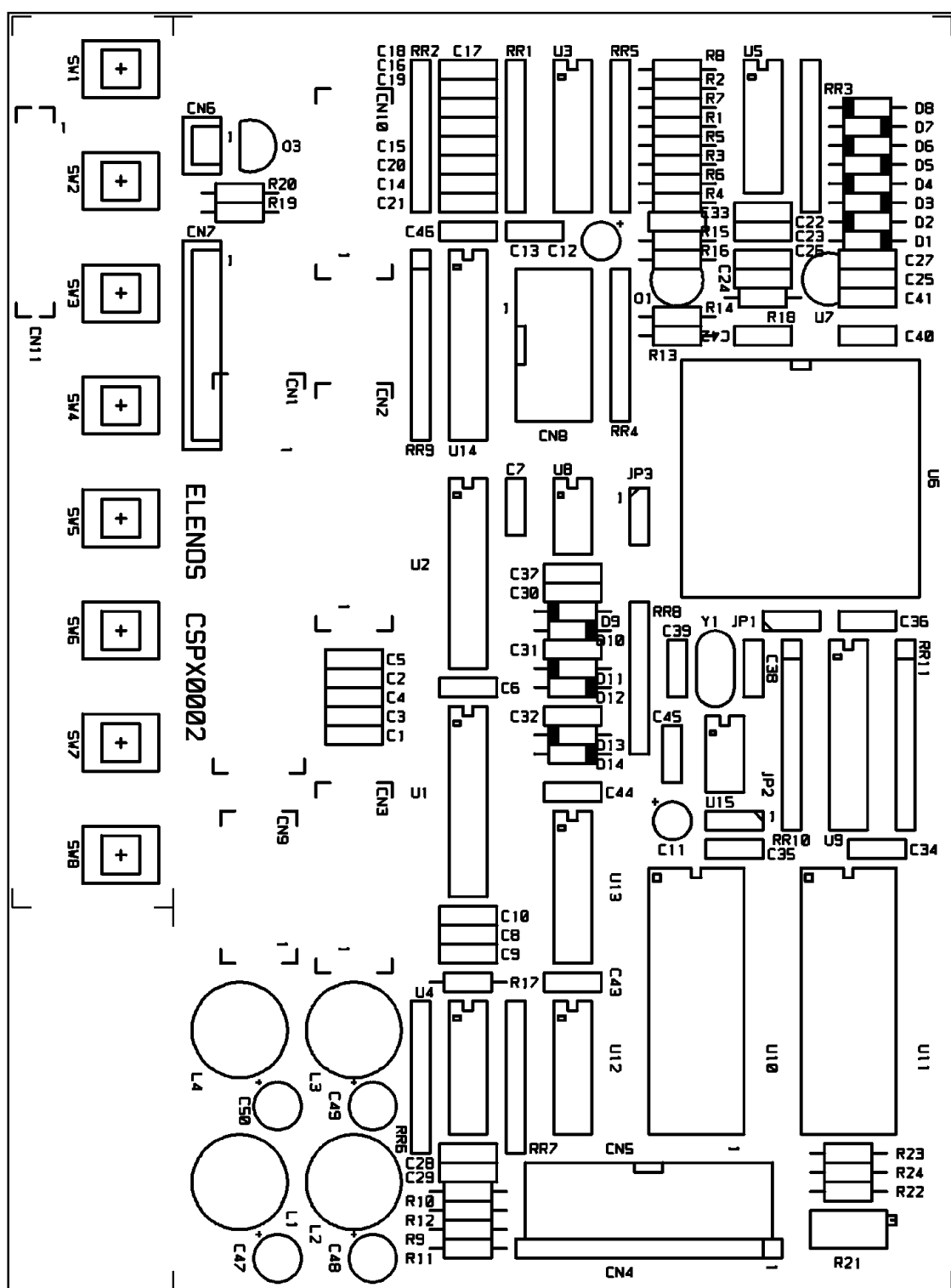

VCO circuit diagram

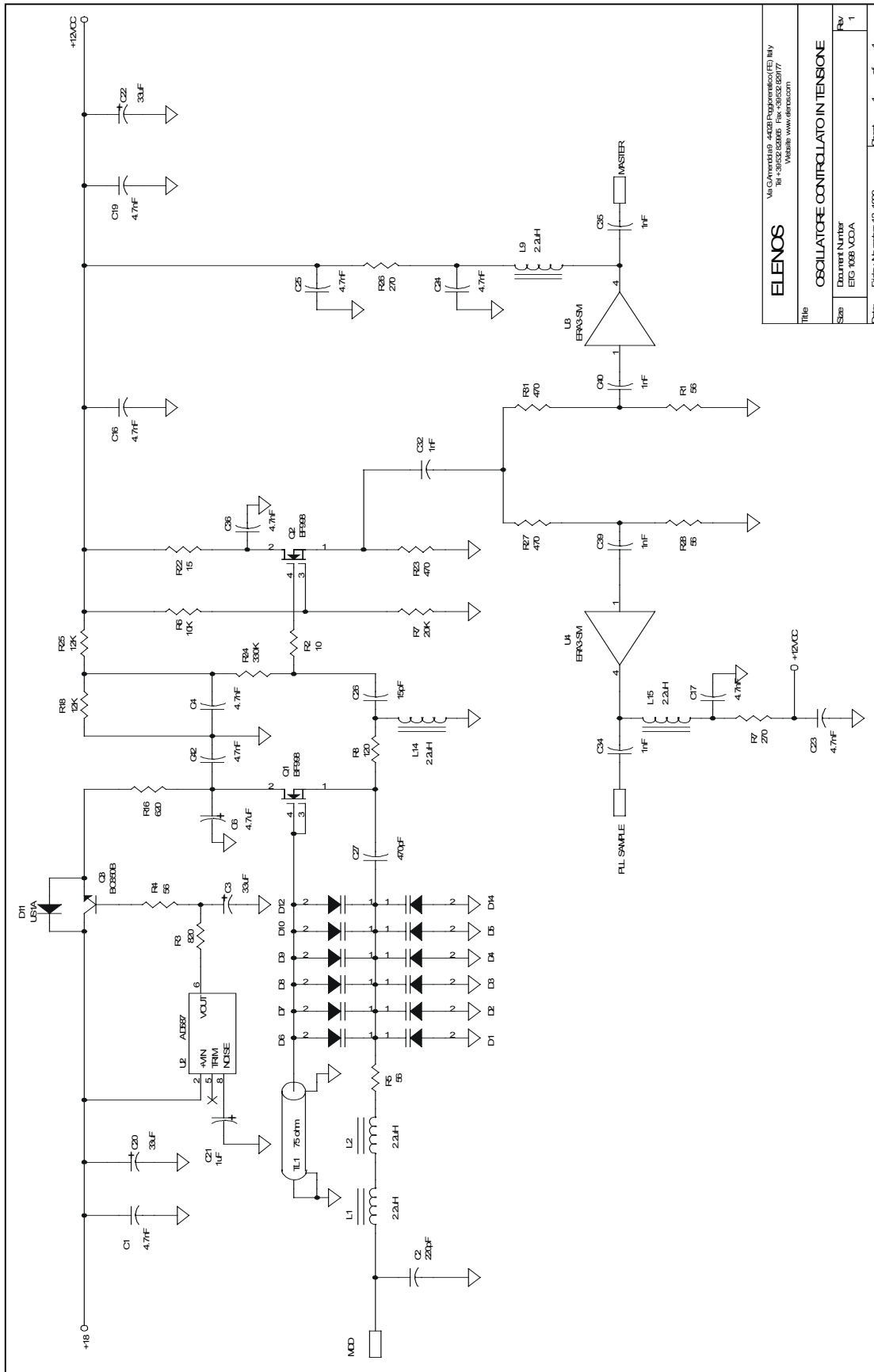

VCO assembly drawing

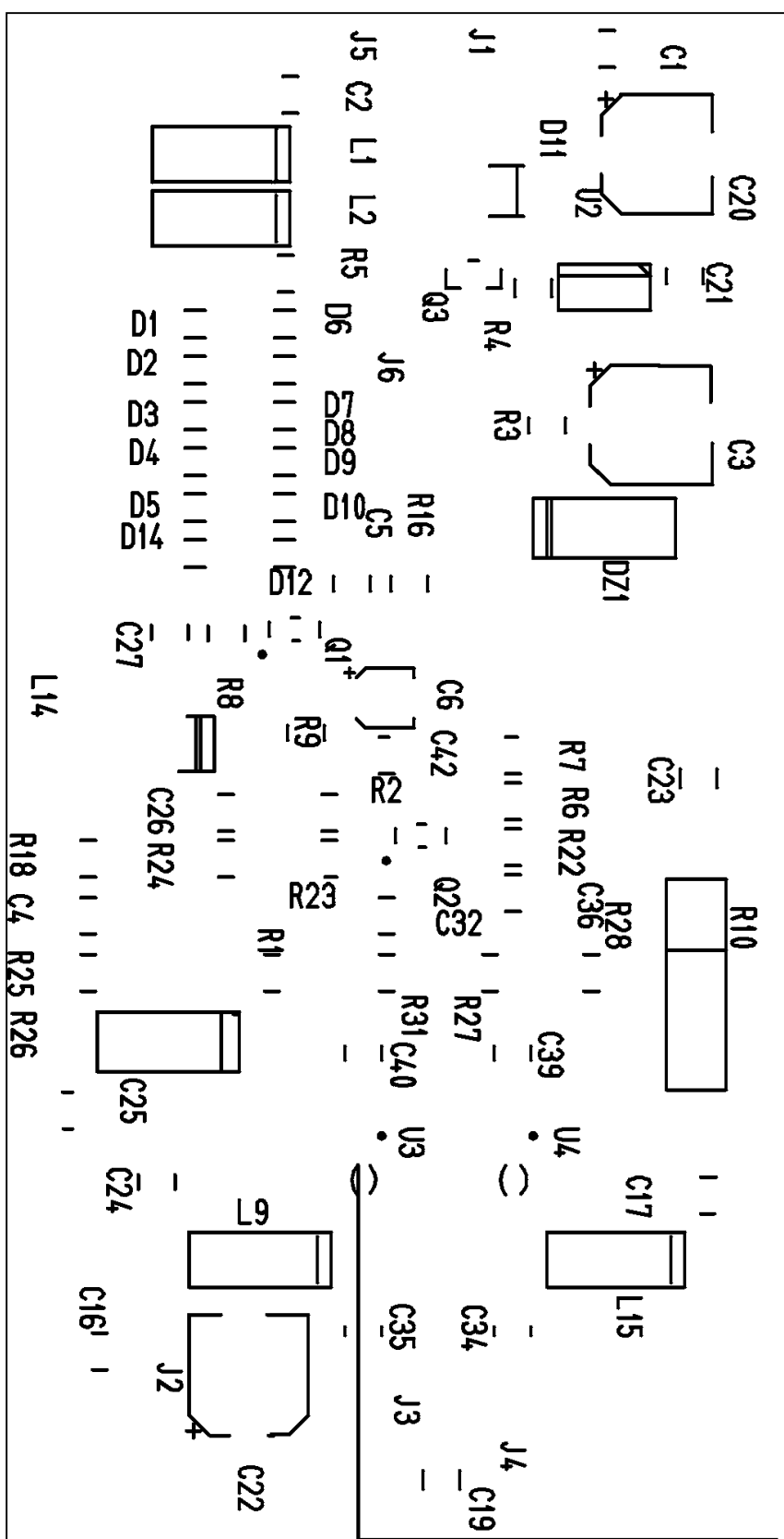

PLL circuit diagram

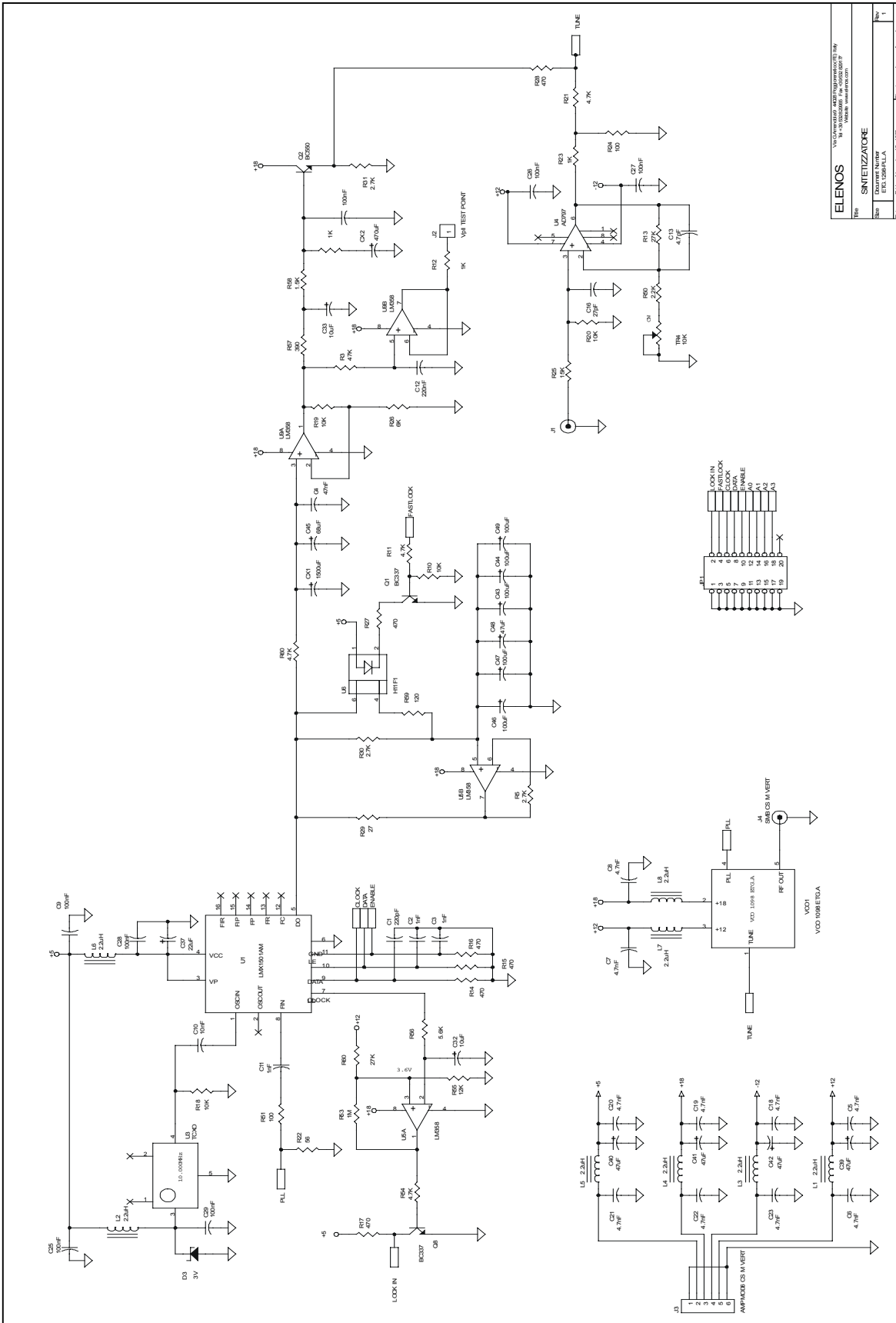

PLL assembly drawing

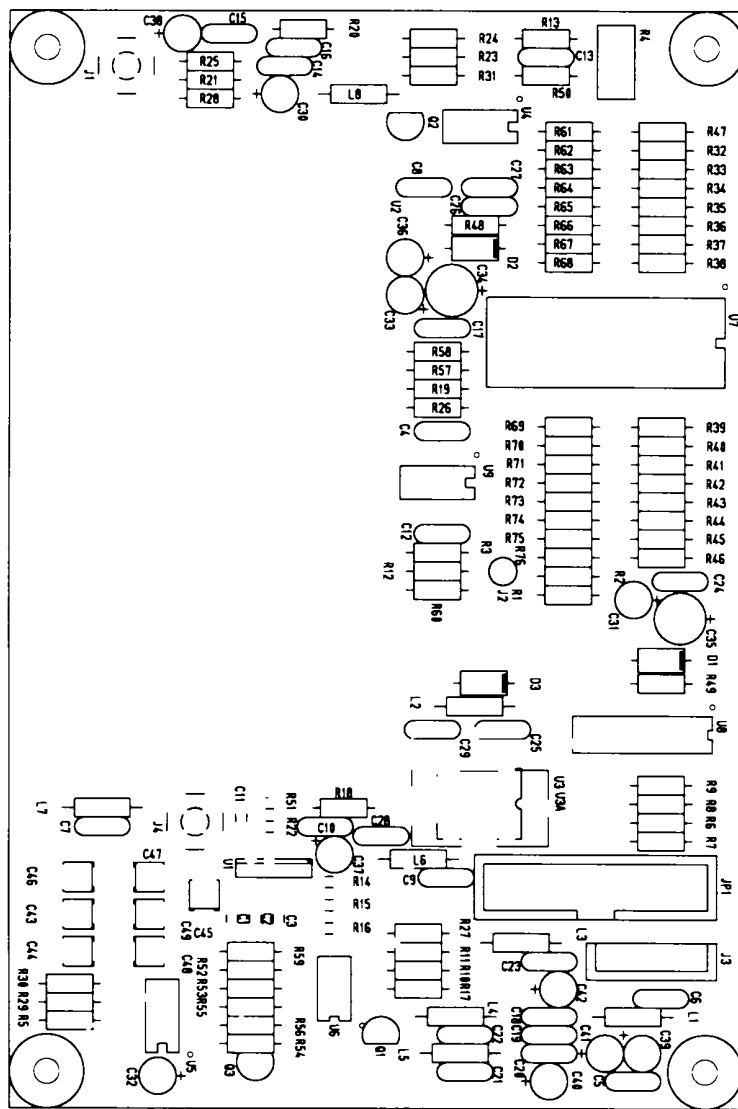

RF Output Filter circuit diagram

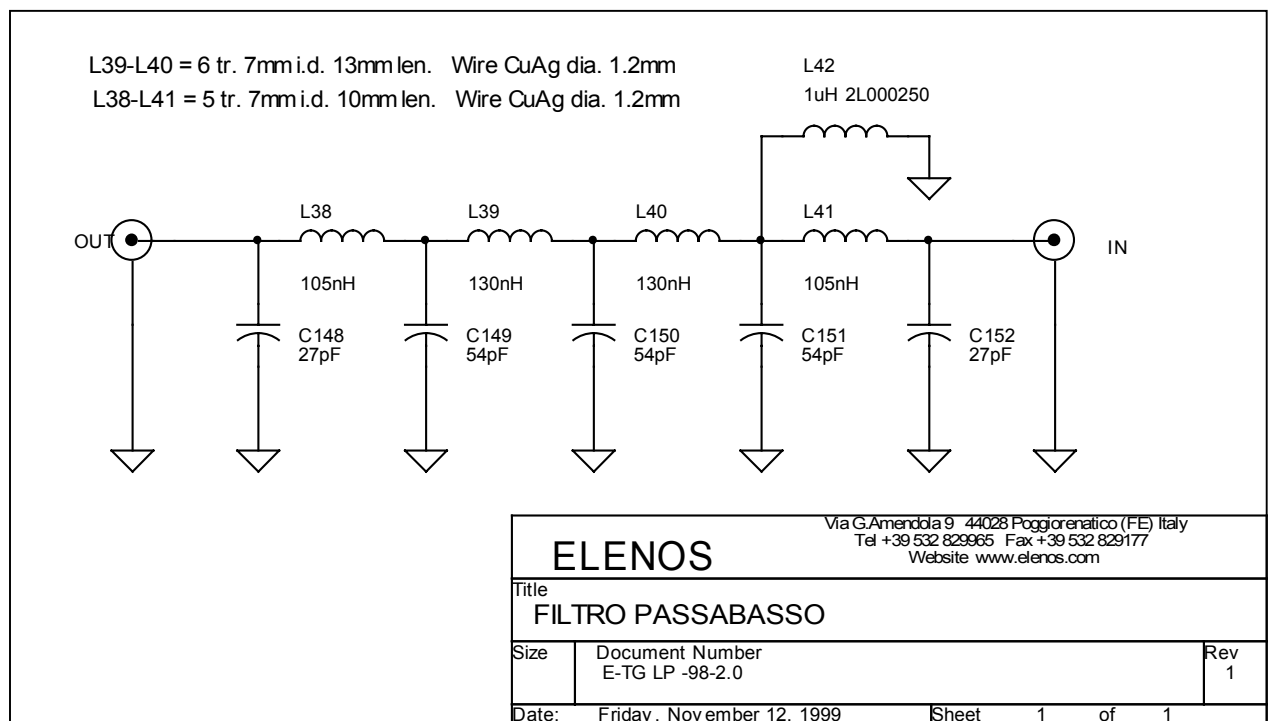

RF Output Filter assembly drawing

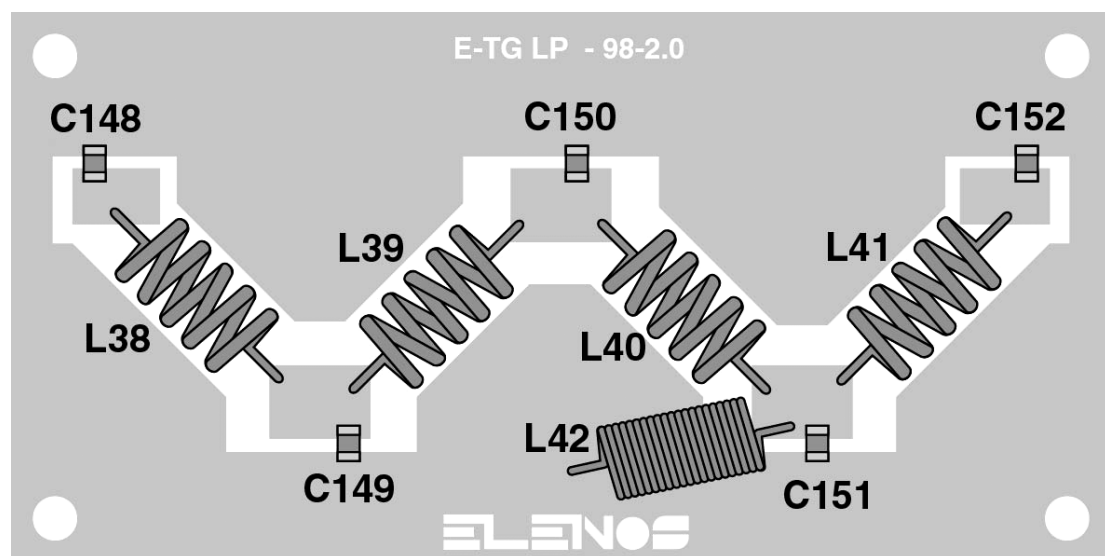

Output Amplifier circuit diagram

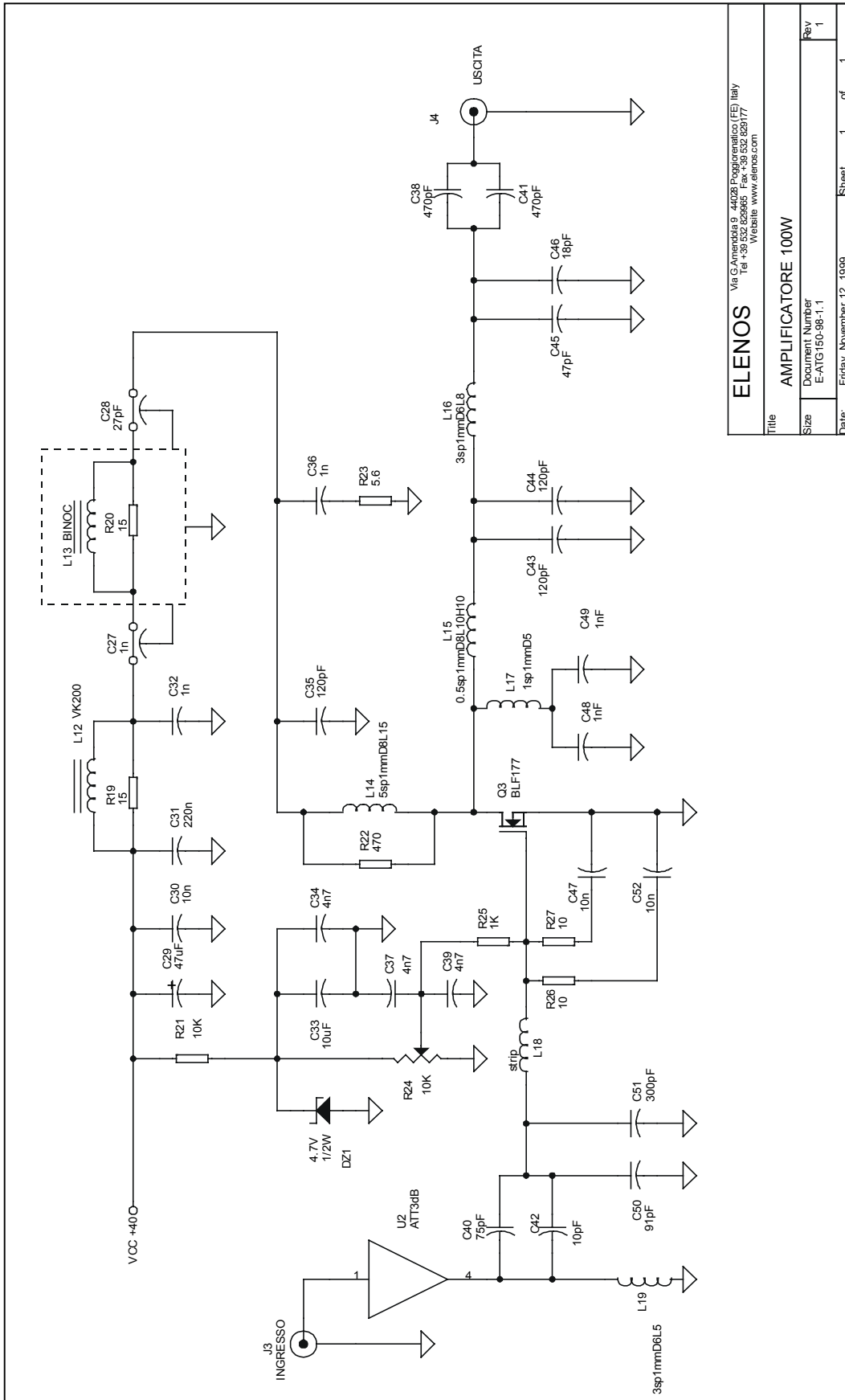

Title ELENOS Via Garibaldi, 6 - 44029 Fontanafredda (FE) Italy Tel. +39 052 829685 Fax +39 052 829177 Website: www.elenos.com	
Document Number AMPLIFICATORE 100W	
Size E-ATG 150-98-1.1	Rev 1
Date Friday, November 12, 1999	Sheet 1 of 1

Output Amplifier assembly drawing

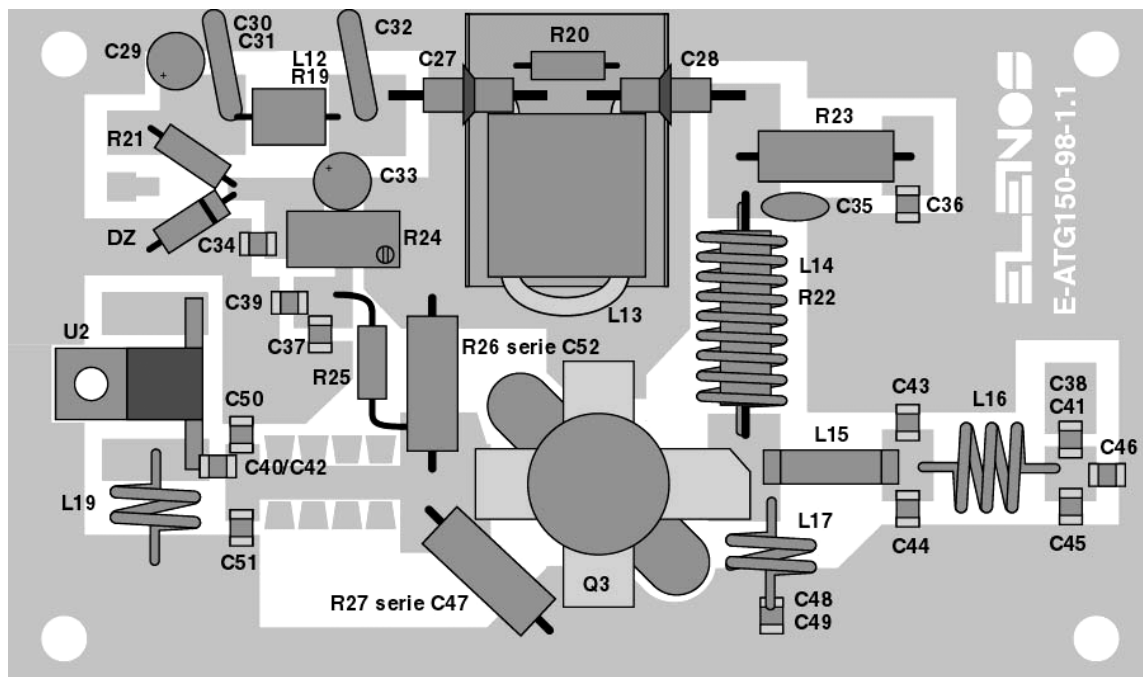

Driver circuit diagram

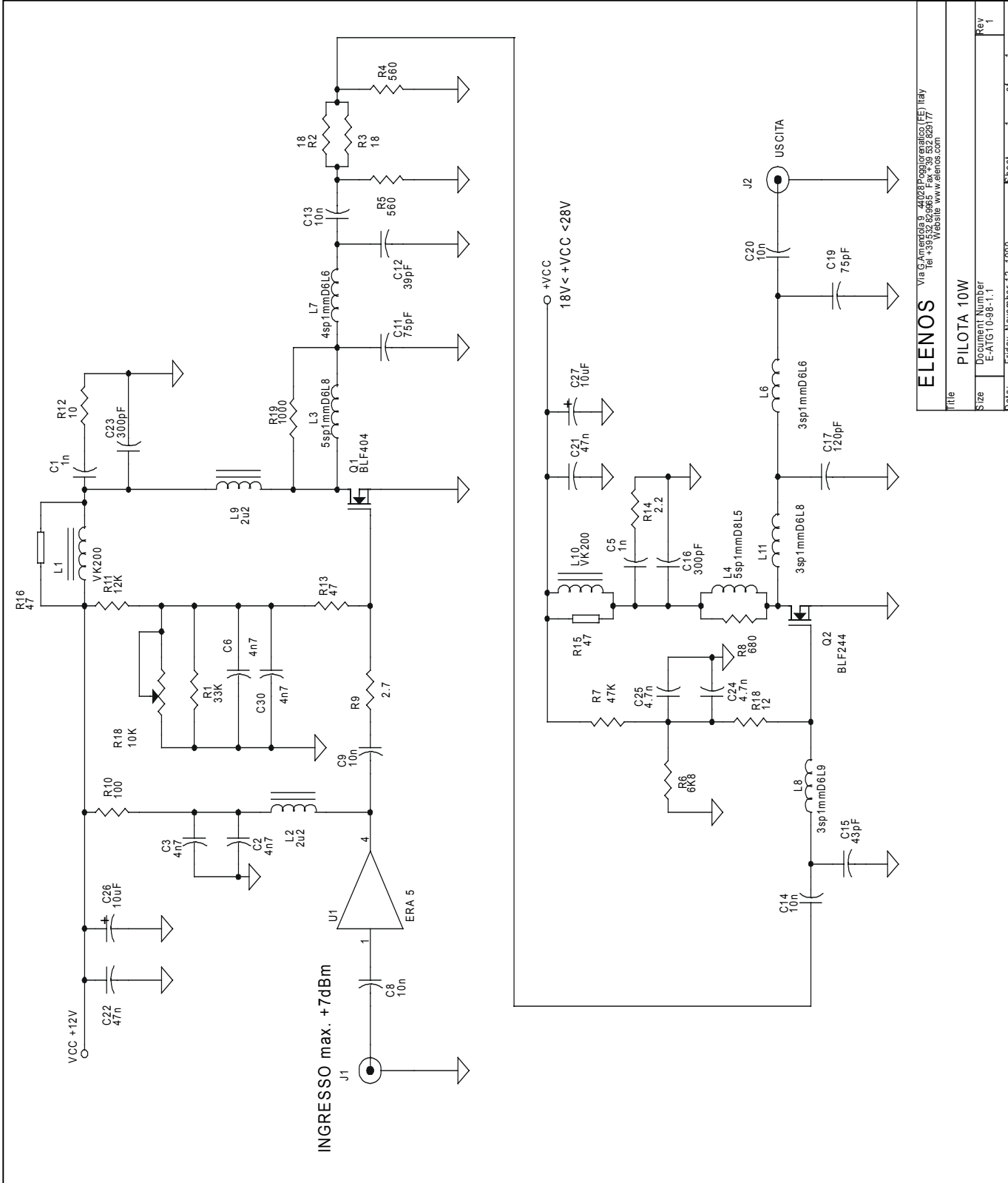

ELENOS Via G. Amendola, 1 - 02027 Poggibonsi (SI) Italy
 Tel. +39 0578 220000 Fax +39 0578 220017
 Website: www.eLENOS.com
PILOTA 10W
 Document Number
 E-ATG 10-98-1.1
 Date: Friday, November 12, 1999 Sheet 1 of 1
 Rev 1

Driver assembly drawing

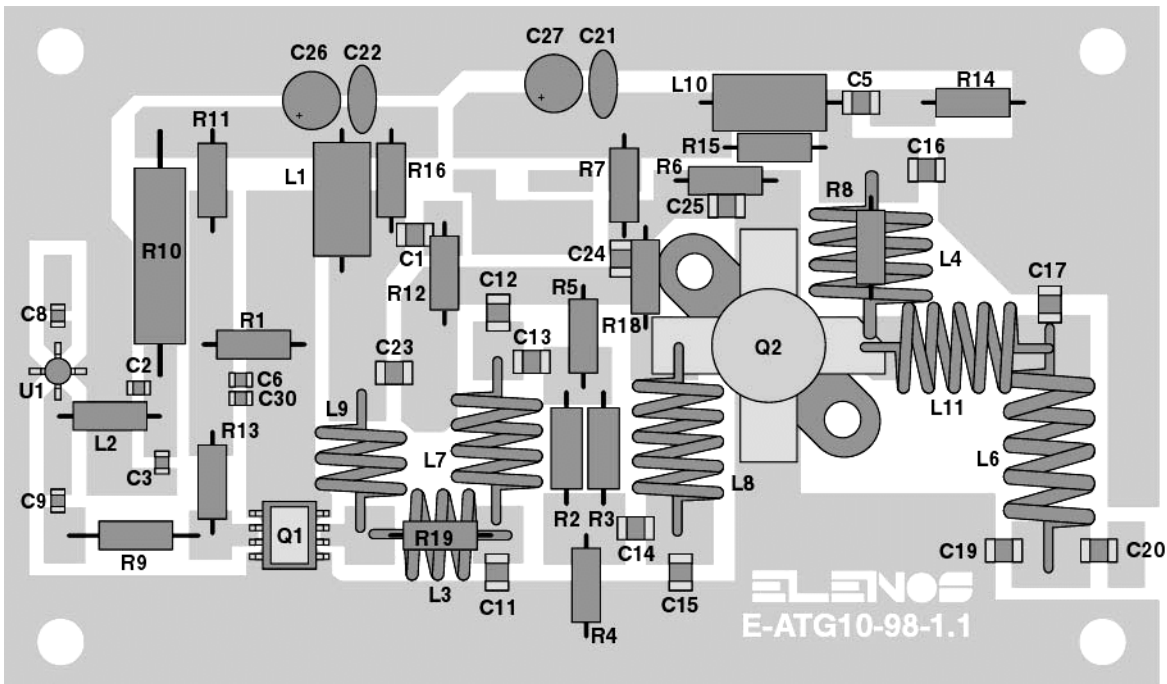

Directional coupler circuit diagram

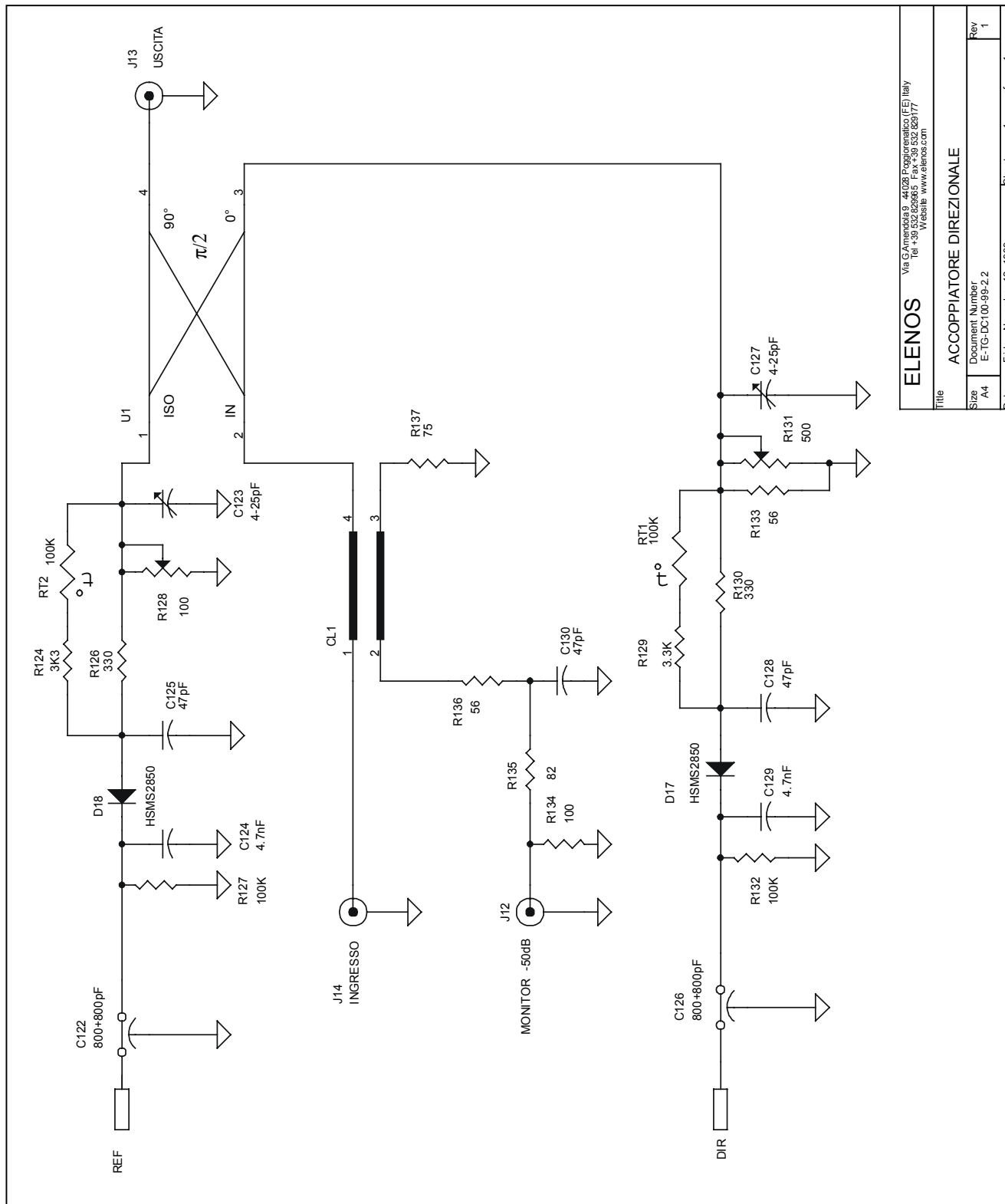

ELENOS		Via G. Amendola, 4028 Poggendorfino (FE) Italy	
Title		ACCOPPIATORE DIREZIONALE	
Size	A4	Document Number	E-10-DC100-99-2.2
Rev	1	Date	Friday, November 12, 1999
Sheet	1	of	1

Directional coupler assembly drawing

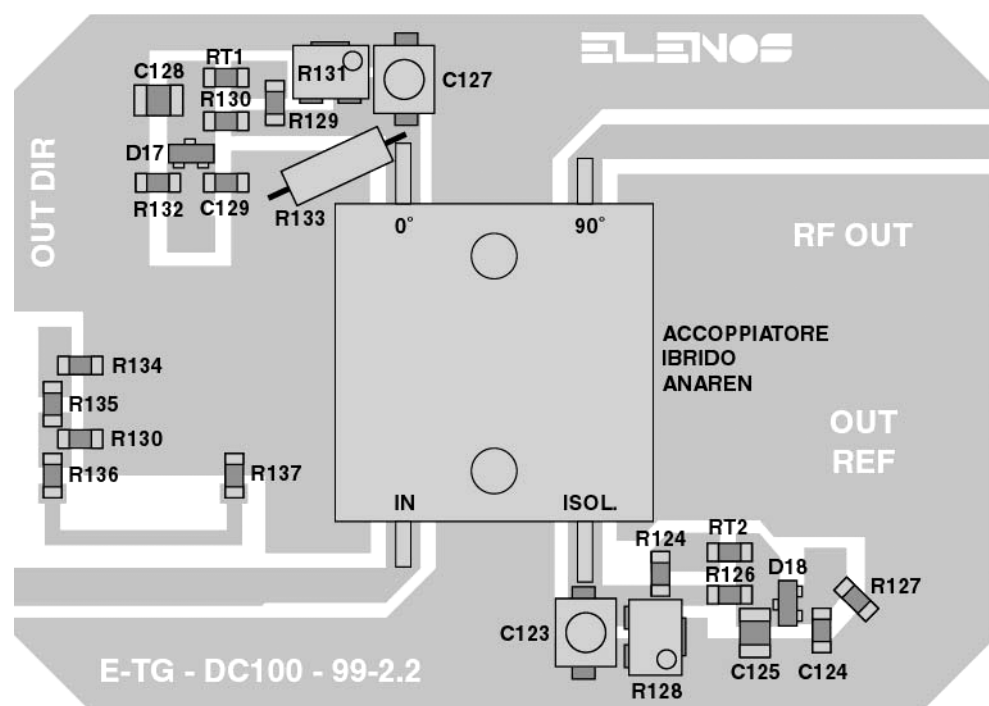

Directional coupler amplifier circuit diagram

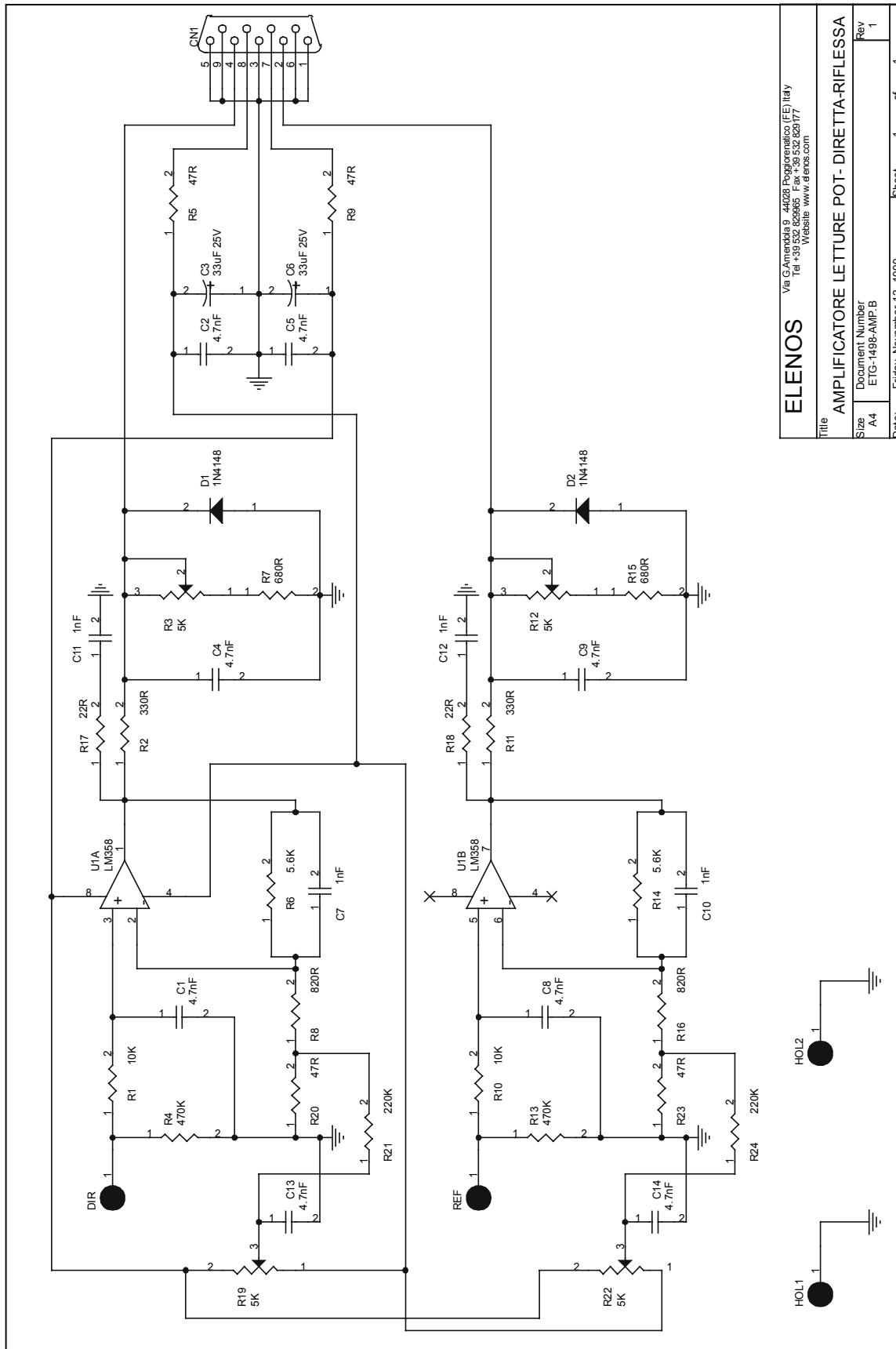

ELENOS		Via G. Amendola 9 - 44026 Poggendorfino (FE) Italy Tel +39 052 829665 - Fax +39 052 829177 Website: www.eleos.com	
Title AMPLIFICATORE LETTURE POT - DIRETTA-RIFLESSA			
Size	Document Number	Rev	
A4	ETG-1498-AMF-B	1	
Date:	Friday, November 12, 1999	Sheet	1 of 1

Directional coupler amplifier assembly drawing

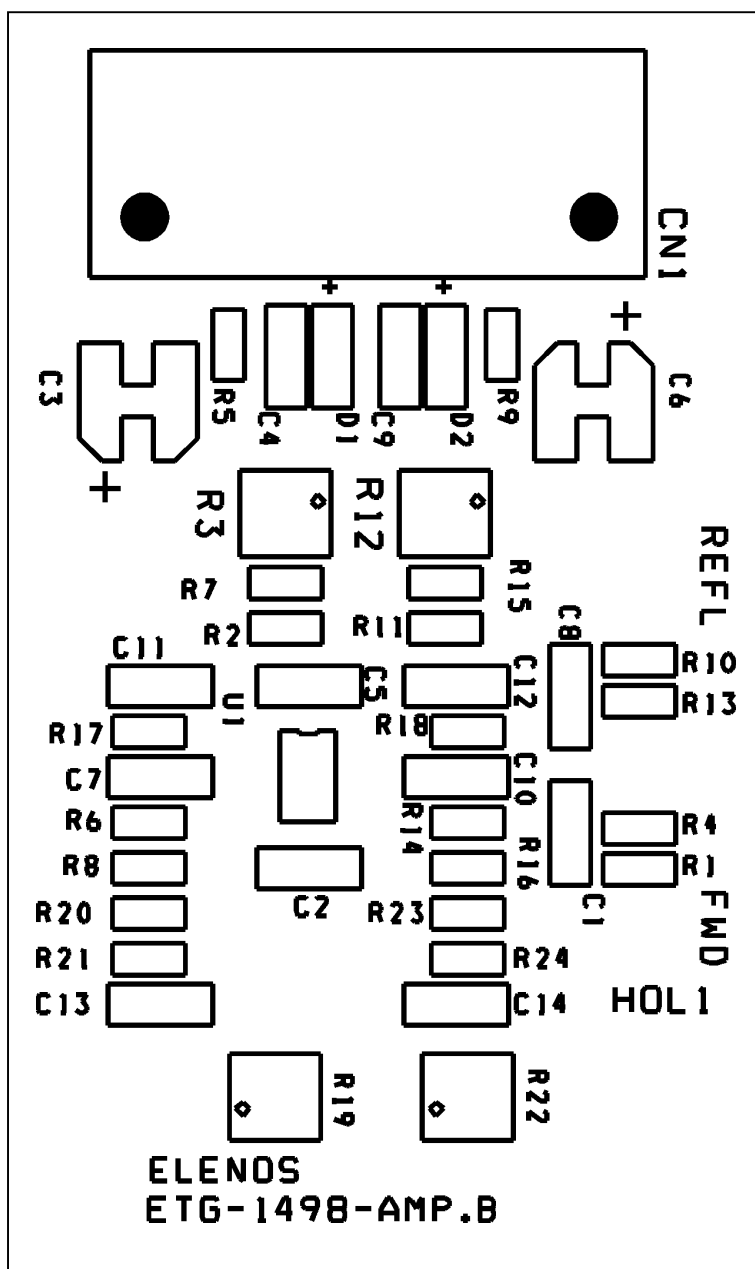

MPX Inputs Card circuit diagram

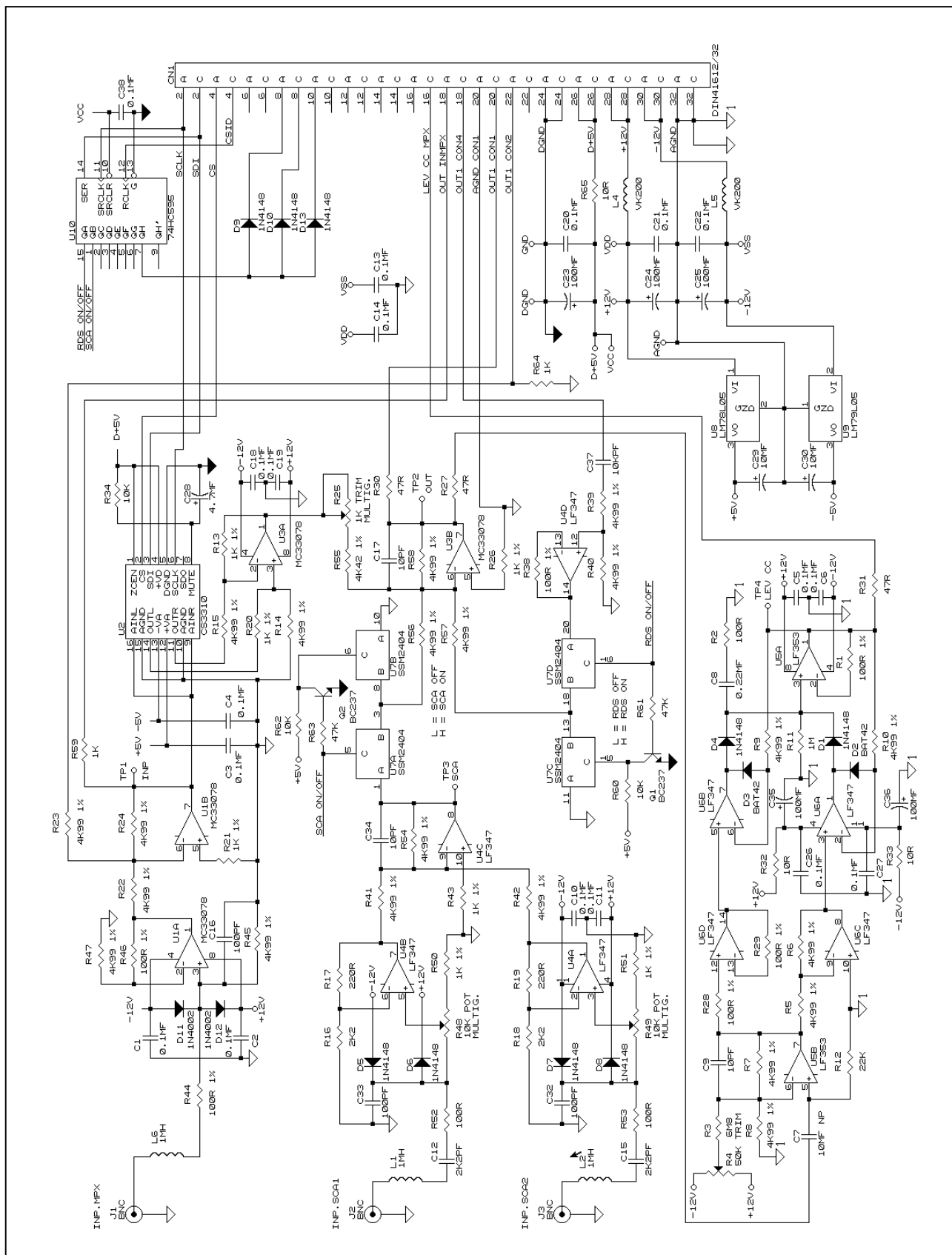

Optional Card BUS circuit diagram

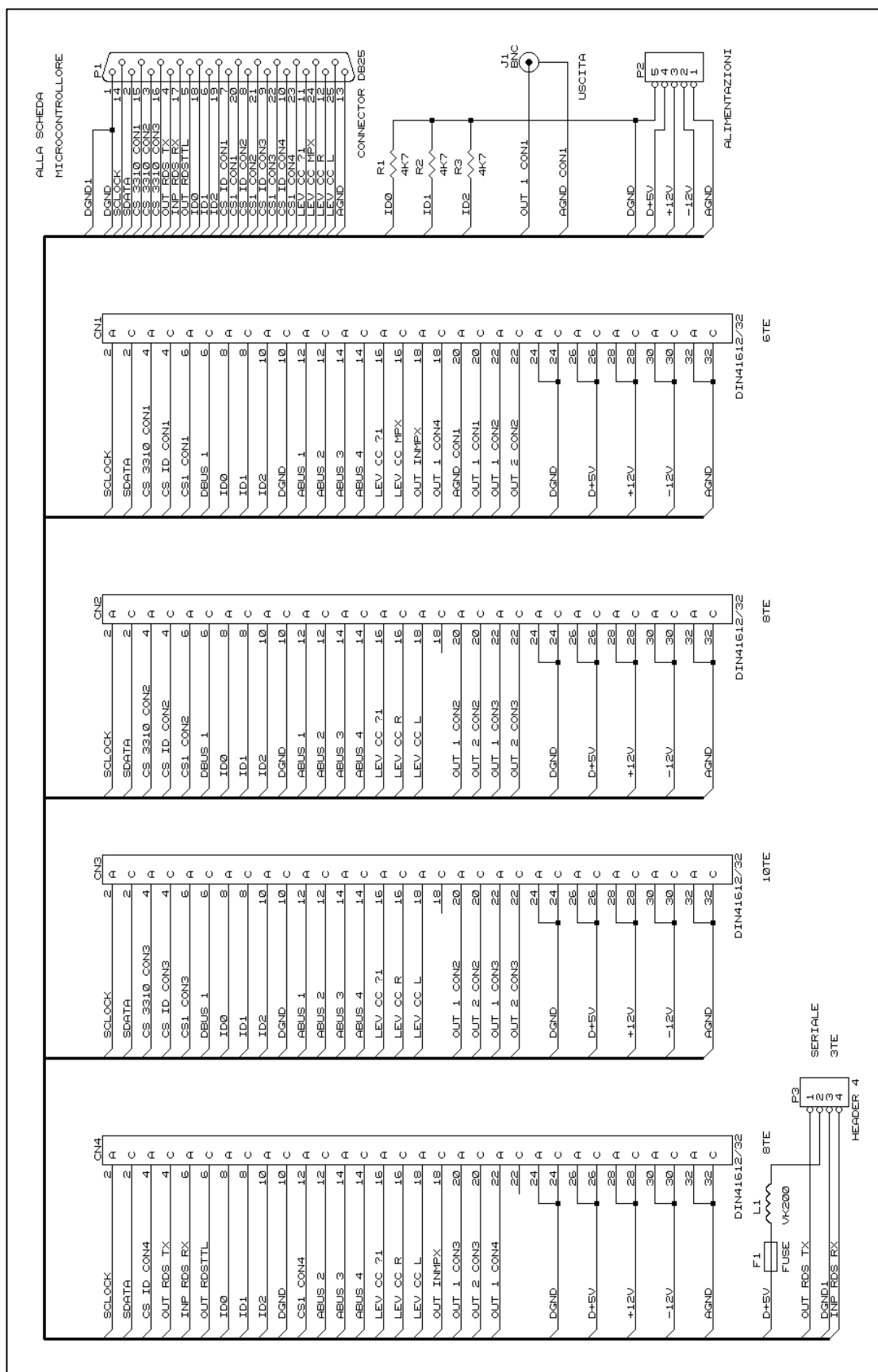

Card BUS assembly drawing

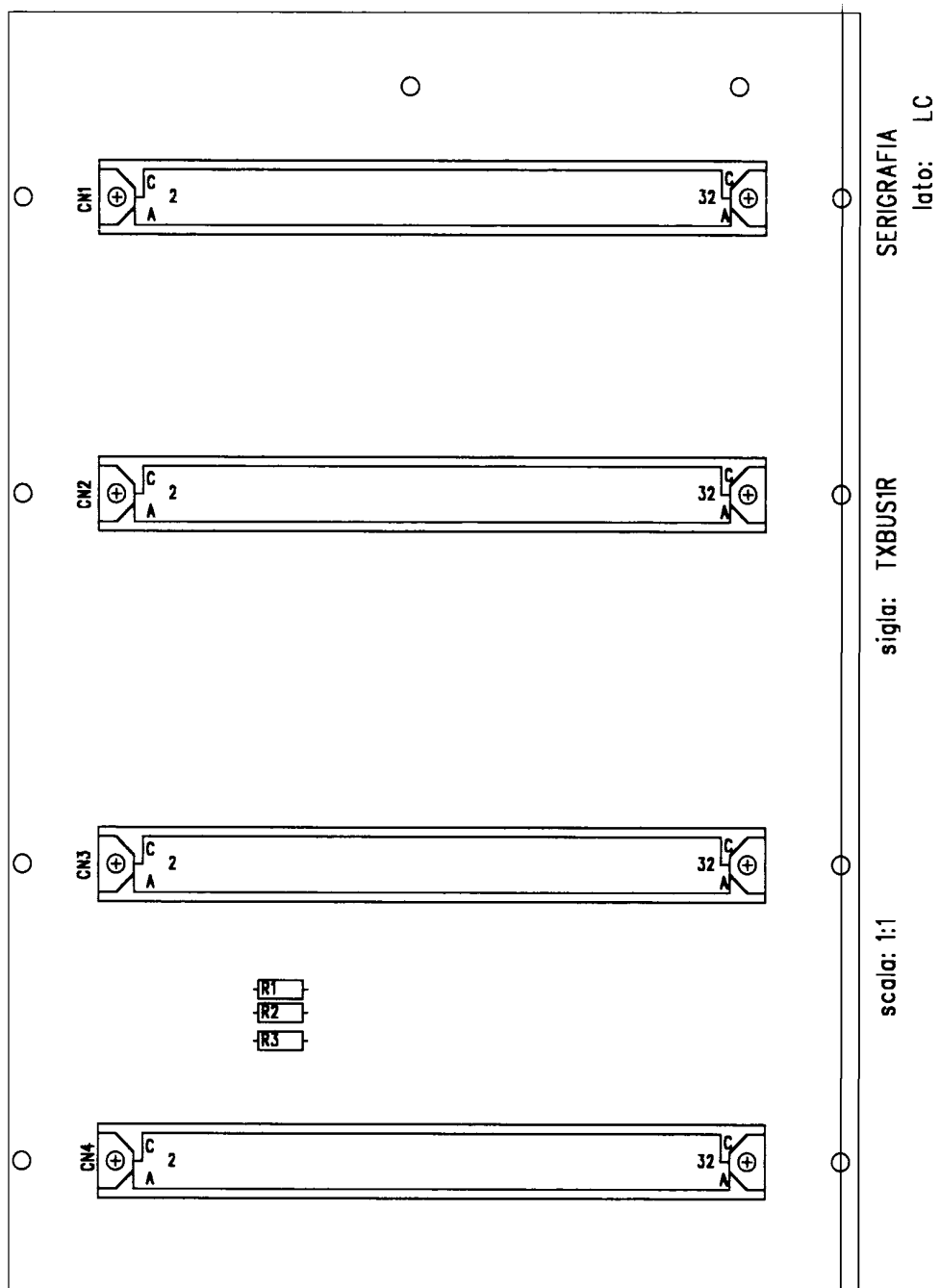

Stereo Input circuit diagram

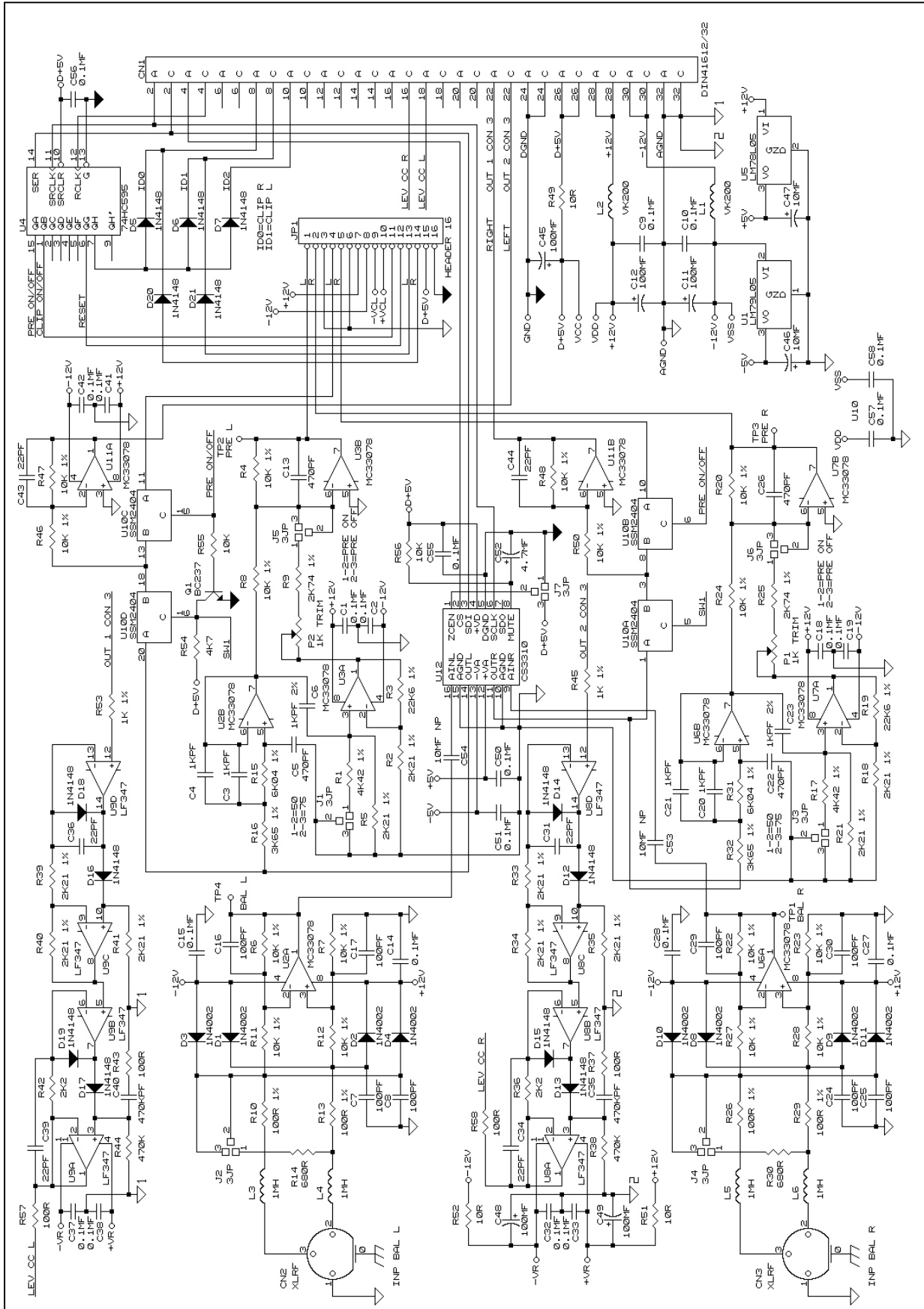

Stereo Input assembly drawing

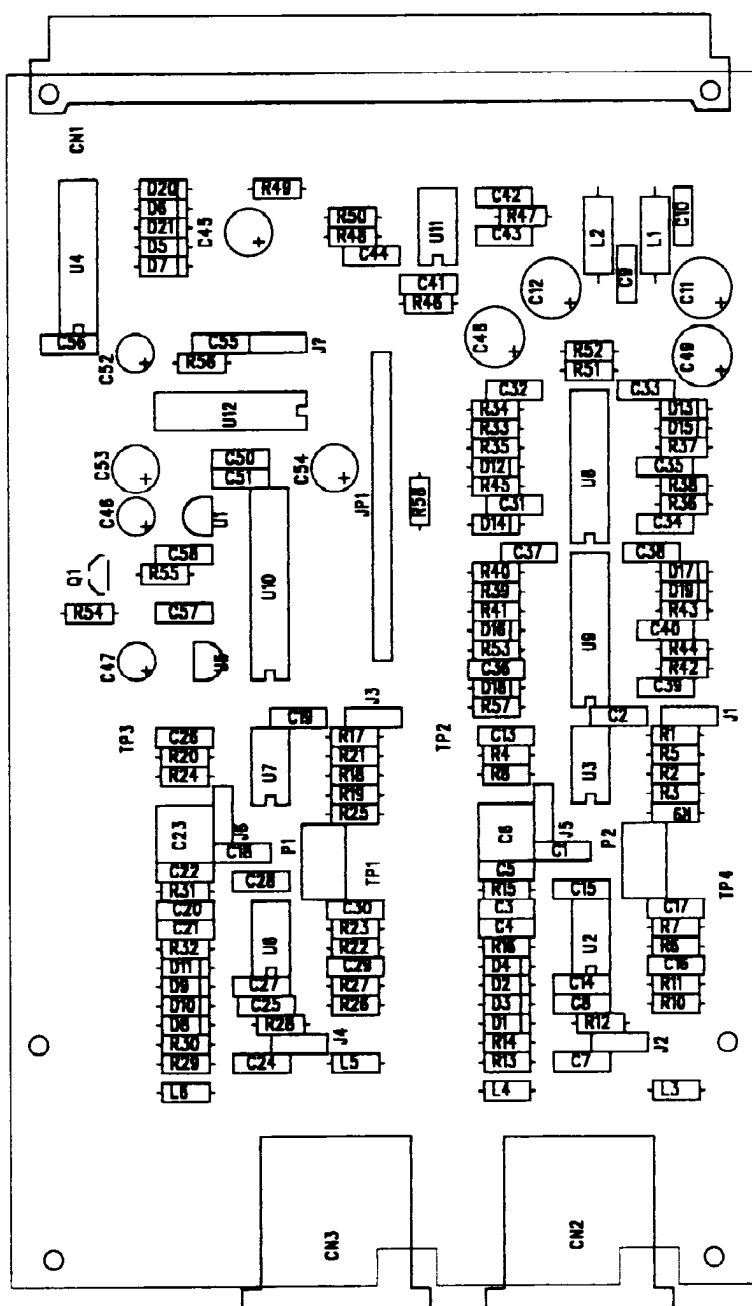

Clipper circuit diagram

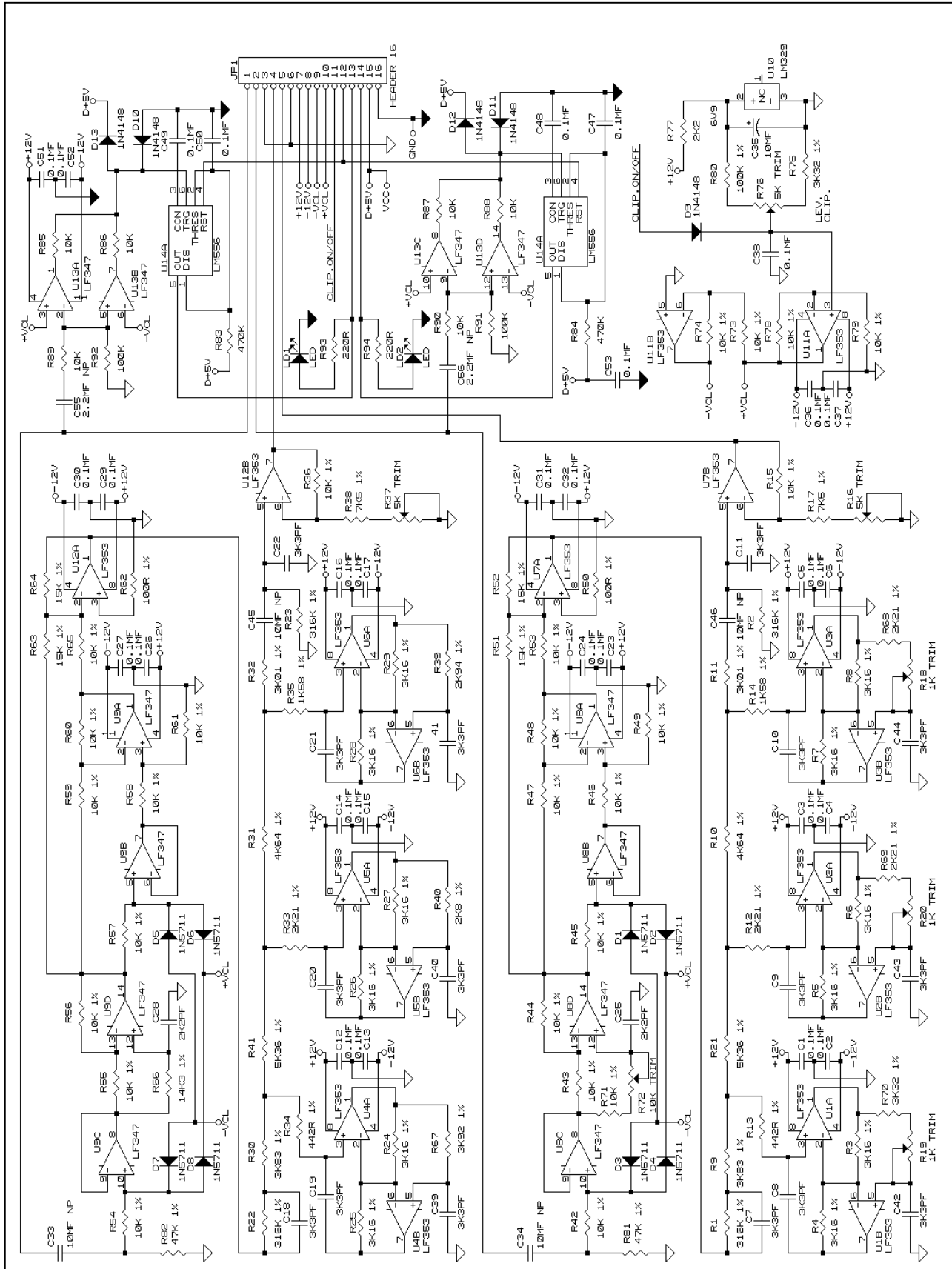

Clipper assembly drawing

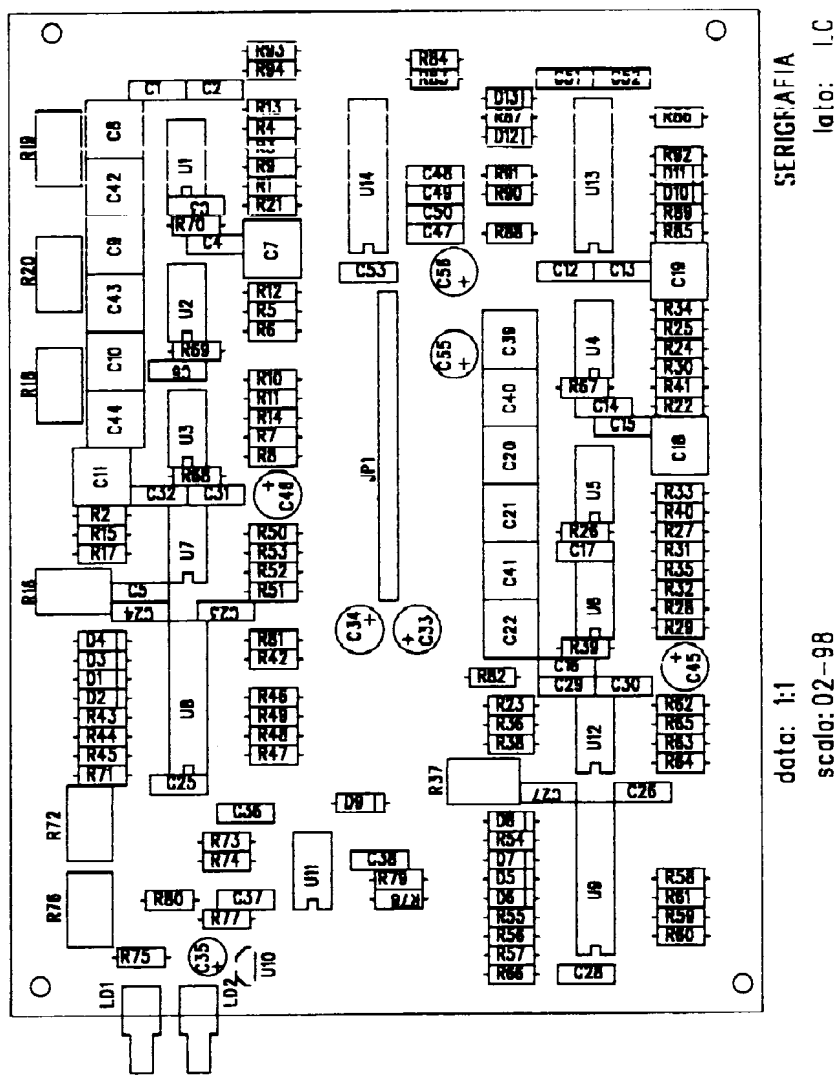

Mono Input circuit diagram

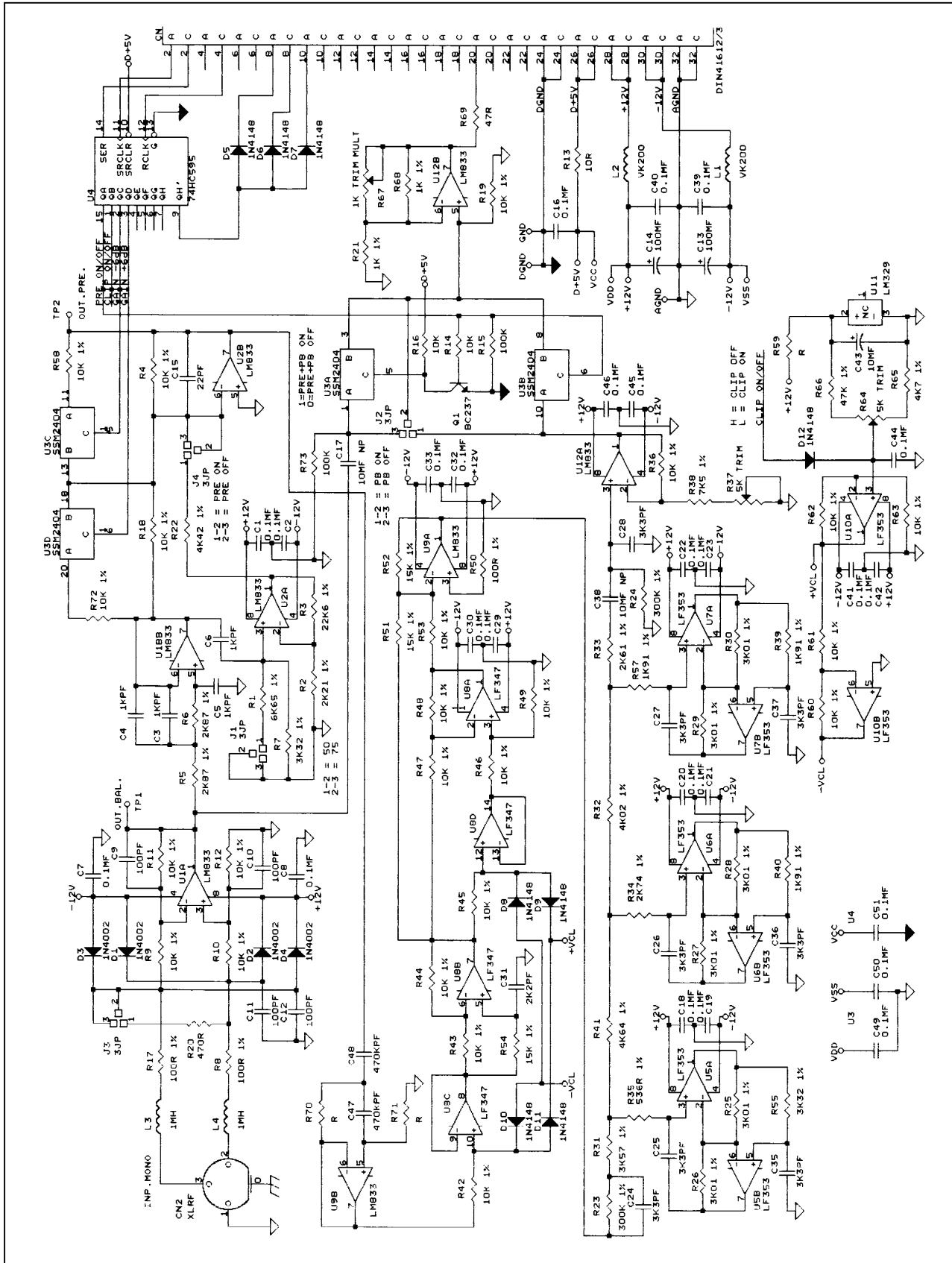

Mono Input assembly drawing

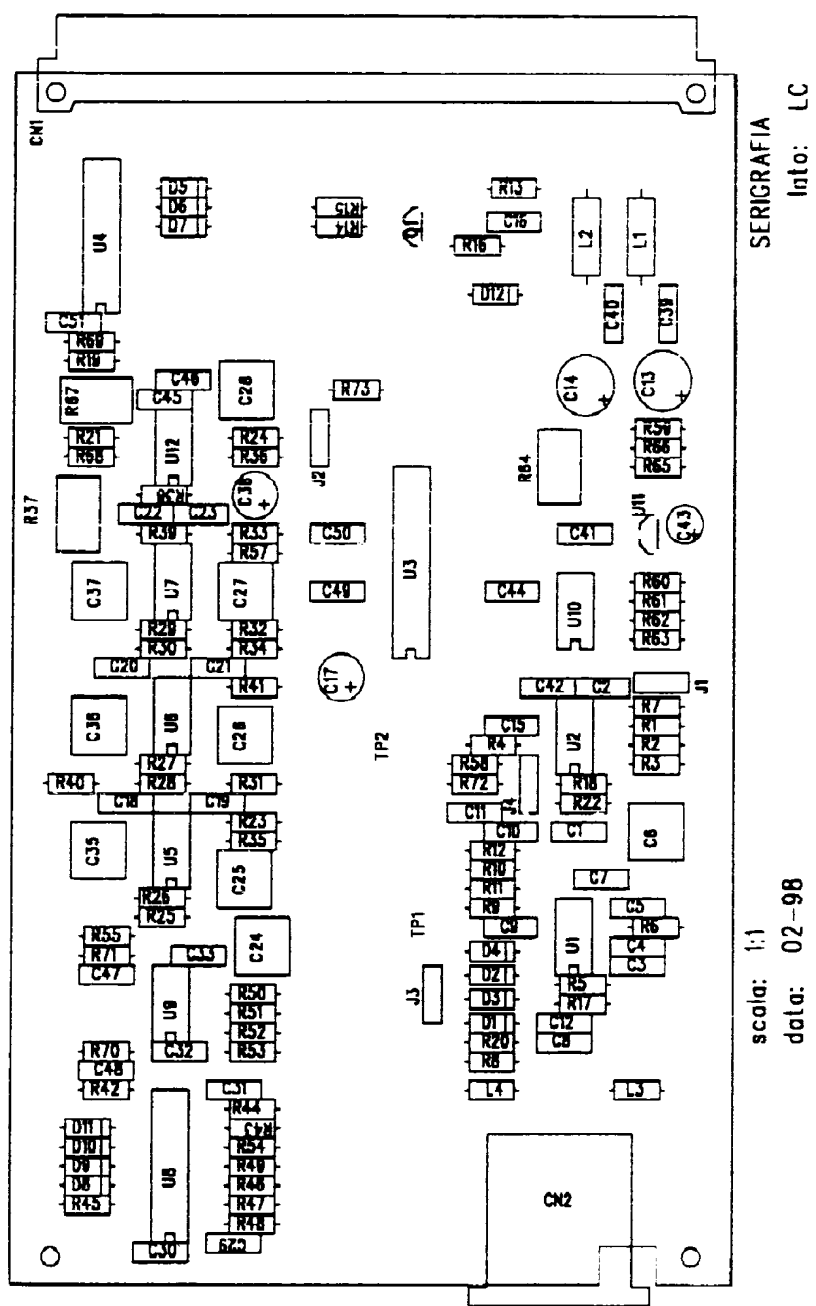

SERIGRAFIA
Info: LC

scala: 1:1
data: 02-98

Stereo Encoder (mpx generator) circuit diagram

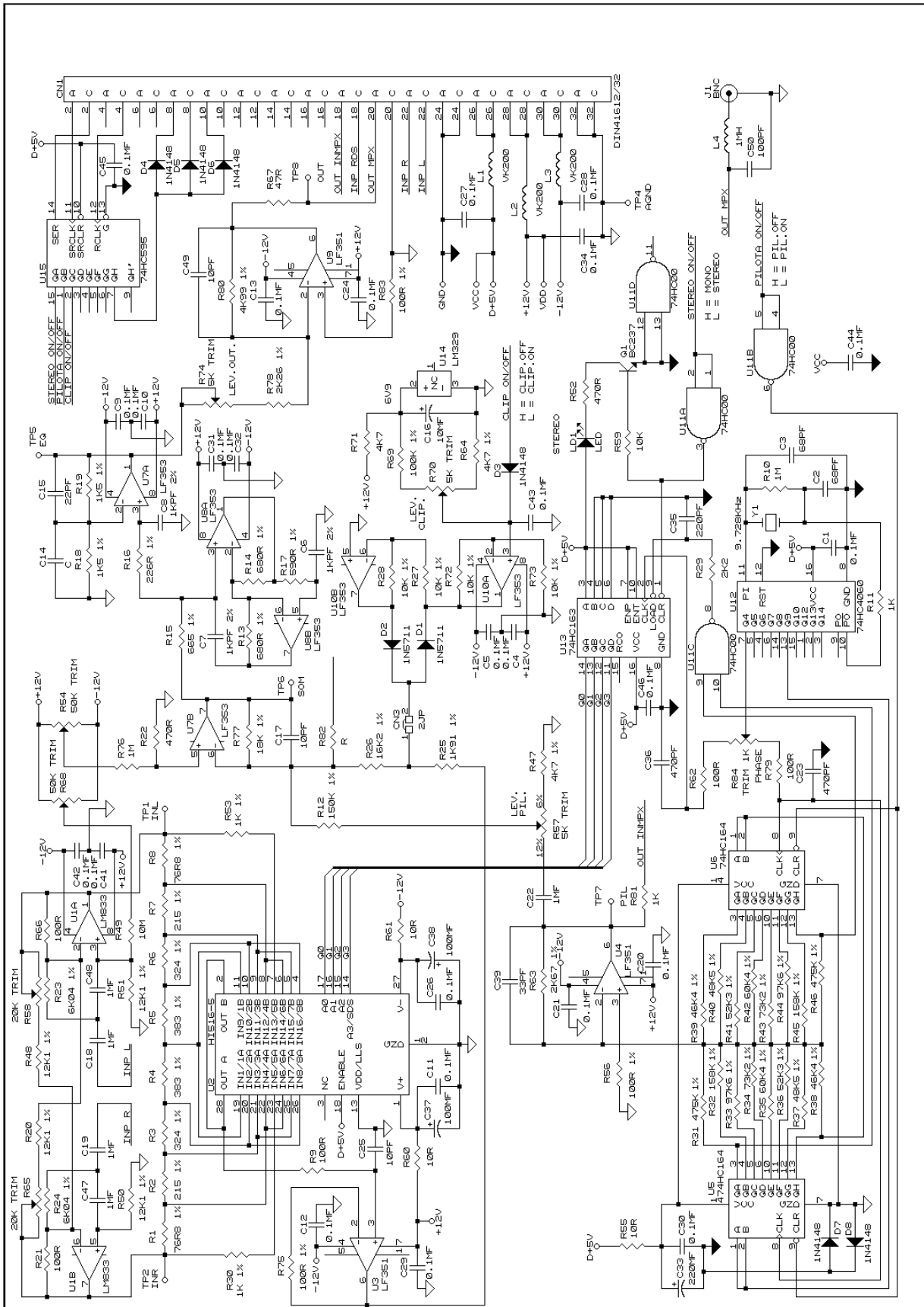

Stereo Encoder (mpx generator) assembly drawing

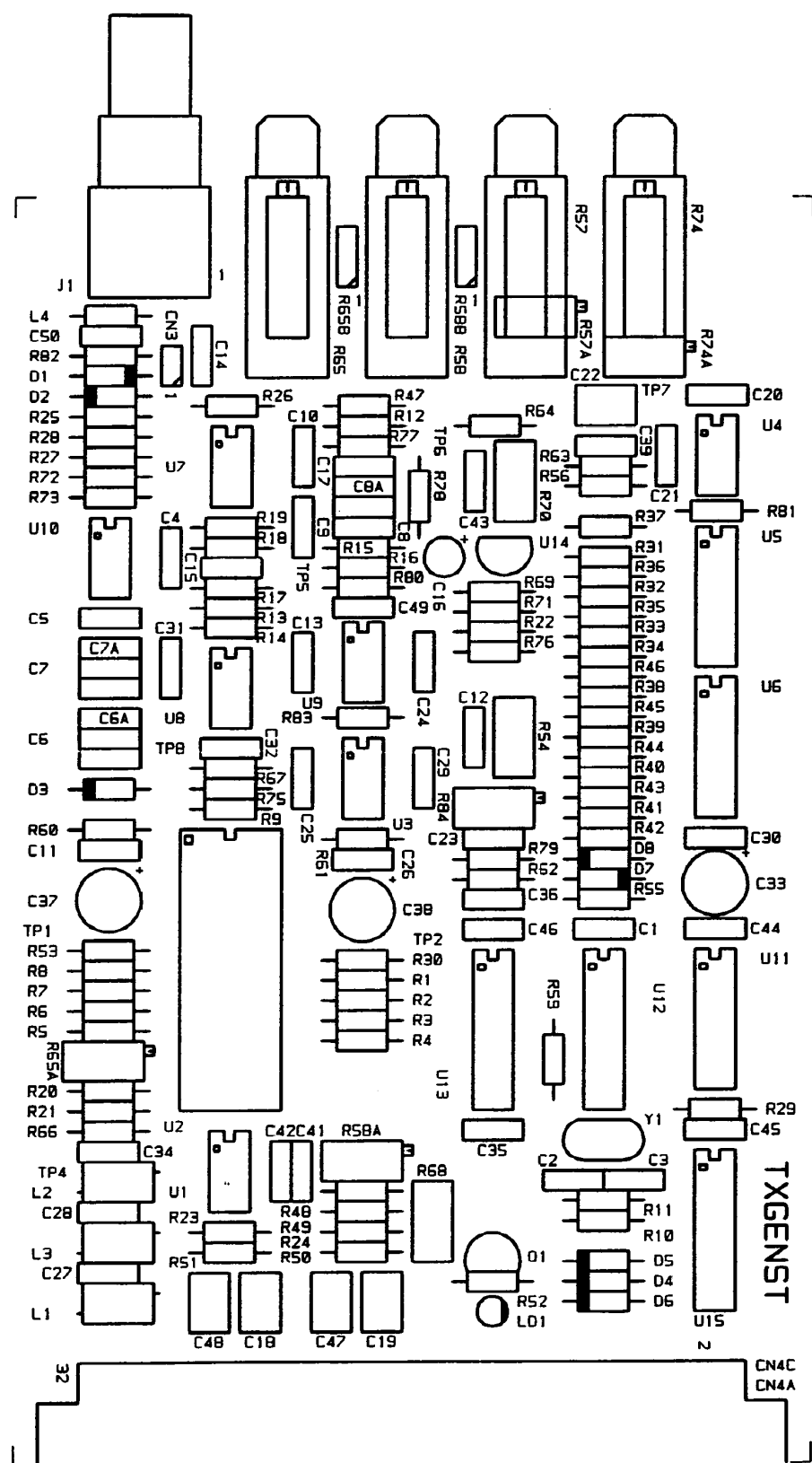

RDS Control circuit diagram

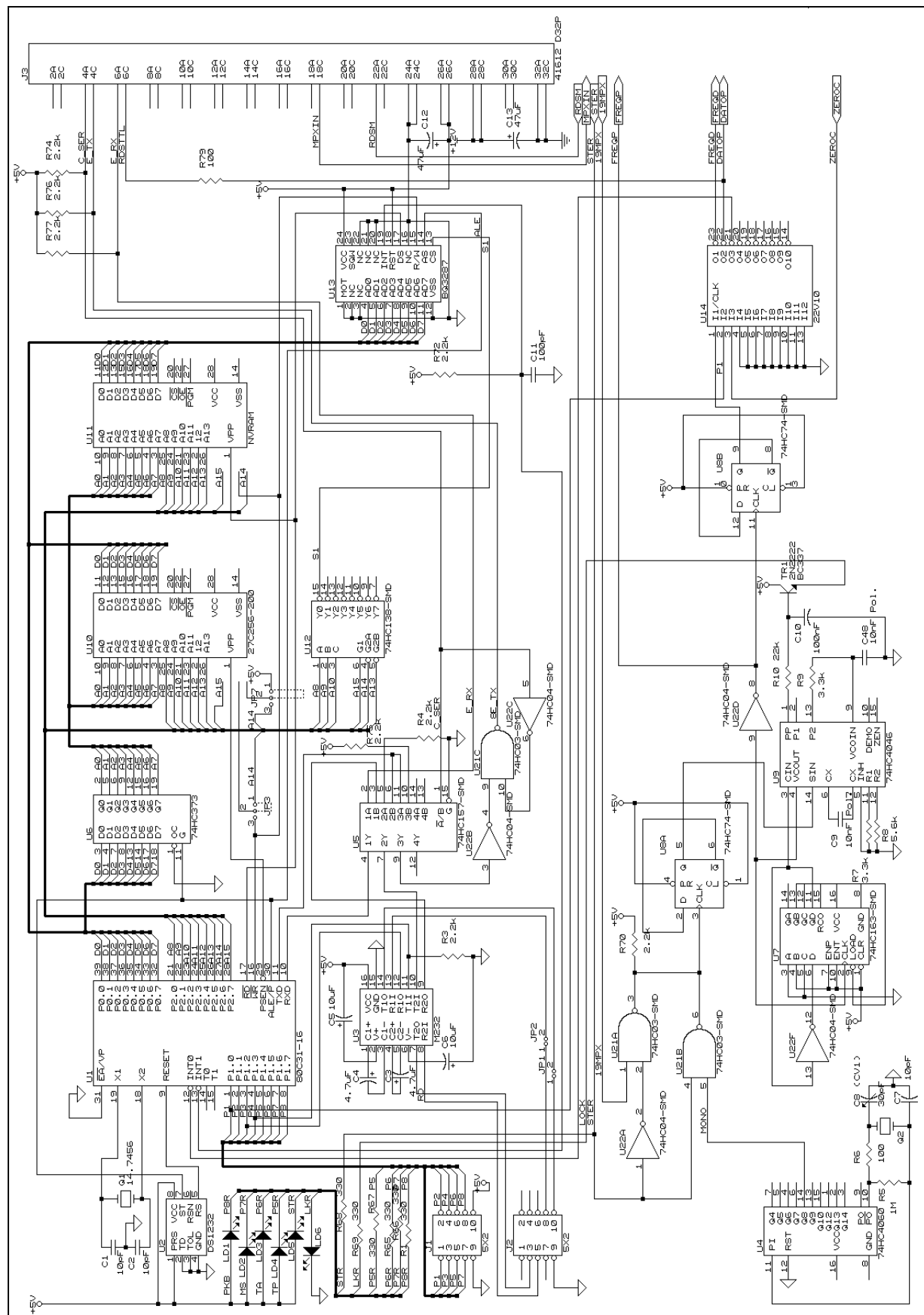

RDS card assembly drawing

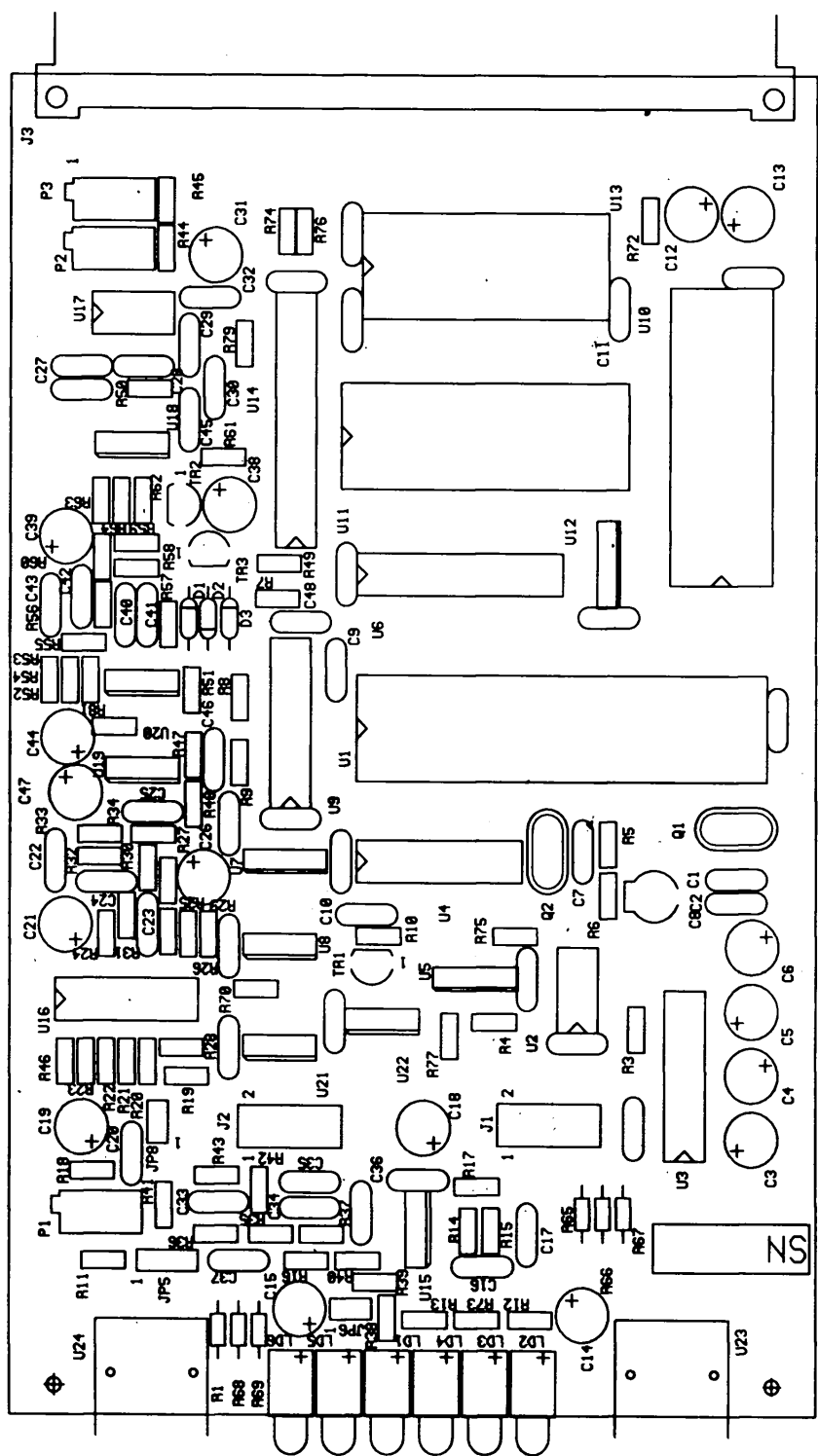

Cannon XLR wiring

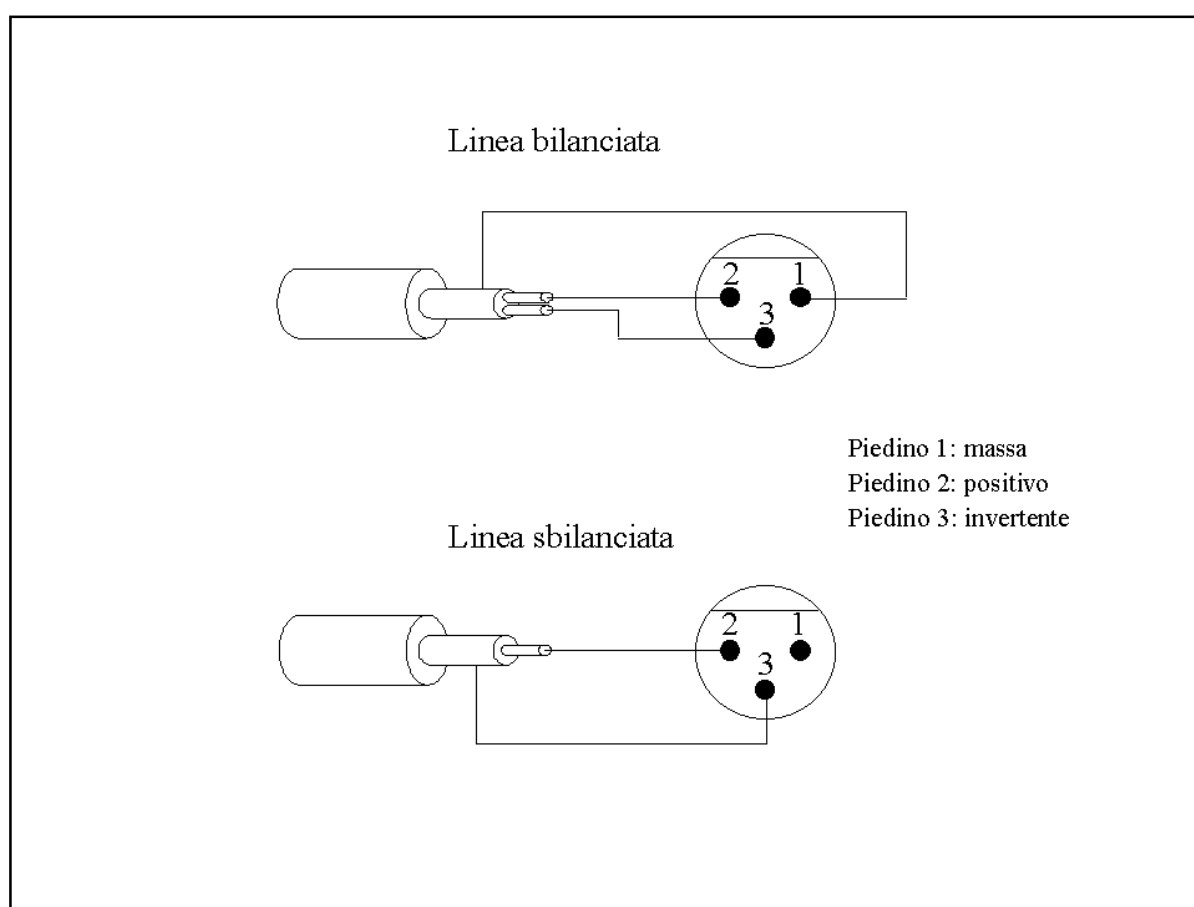

16 – GENERAL CONDITIONS OF SALE

The General Conditions of Sale which follow apply to all offers and sales made by Elenos to its customers. Purchasing products from Elenos will subject the purchaser to the General Conditions of Sale considered individually or as a whole.

OFFERS AND ORDERS

- Offers made by Elenos, whether verbal or written, are not binding.
- Orders must be made in writing.
- If a purchaser places an order, either verbally or by telephone, a written order must follow within one week.
- All orders received by Elenos are considered as accepted if confirmed in writing.

DELIVERIES

- Delivery times are indicative and non-binding upon Elenos. In the case of delayed delivery, the purchaser has no right to cancel the order, in total or in part, without express agreement in writing.
- Elenos is not obliged to compensate for direct or indirect damages as a consequence of late delivery or total or partial failure to deliver.

SHIPPING

- Goods are supplied ex-works Elenos and travel at the risk of the purchaser, even if transport is free of charge.

PRICES

- With the exception of contractual agreements, prices applied are those in use at the time of transport or delivery of the goods, and the prices are ex-works Elenos. The purchaser is liable for packing charges.
- Elenos reserves the right to change its price lists, without notice, in accordance with variations in the production costs of raw materials and currency exchange fluctuations.

PAYMENT CONDITIONS

- Payments must be made directly to the Elenos registered office in accordance with the terms and conditions agreed, even in the event of delayed arrival of the goods, or partial or total loss of the goods during transport. This holds also in the event that the goods are made available for the purchaser to collect who fails to do so.
- In the case of late payment, the purchaser is liable to pay interest charges to Elenos of 15% over and above the official annual bank interest rate, plus expenses.

GUARANTEE

- The guarantee period is 12 months from the date of shipment, unless otherwise agreed with Elenos S.r.l.
- The guarantee is extended to a period of twenty-four (24) months from the posting date of the registration card and the intervention recording card attached at the end of the present manual, which the buyer must send to ELENOS by registered mail.
- The guarantee does not cover freight or transport insurance costs.
- The guarantee is limited to any malfunction caused by defective components and/or incorrect assembly of such.
- The guarantee excludes all faults that are not the result of a defective product; these include shock damage, atmospheric phenomena, incorrect connection to other components, modifications or unauthorised repairs.
- Elenos extends all those original component manufacturer's guarantees, which are transferable, to the end-purchaser, in the event of claims made directly to Elenos. Elenos will not recognise any form of guarantee for any component defect which the manufacturer of the component attributes to electrical discharge, incorrect line voltage, wear and tear, tampering, negligence or abuse on the part of the user.

Note 1: Any modification or change made without express authorisation will automatically nullify the conditions of the guarantee described above!

Note 2: Verify that the consignment is complete at the time of delivery. No claims will be considered after 5 days from the date of delivery.

- The guarantee can only take force at the premises of Elenos or its authorised service centres.
- It is advisable, in the first instance, to contact the equipment re-seller, who is often able to repair the unit more quickly than the manufacturer. The re-seller frequently identifies installation errors.
- If your re-seller is not able to assist you, contact Elenos to explain the problem. If it is found necessary to return the product, Elenos will supply the authorisation with a returns number and all instructions required for the return of the goods.
- The shipment must be C.I.F. prepaid for return to the address specified by ELENOS.
- Pack and seal the equipment with care, preferably using the original packaging.
- The company will carry out repair work once it has ascertained that the conditions of the guarantee have been met. The company's decision is final in this respect. Ensure that a description of the problems encountered is supplied with the equipment.

In the case of a legitimate dispute, Elenos reserves the right to decide whether to concede a reduction in the sales price, or to change the non-functioning component free of charge.

The purchaser is obliged to observe all legal and safety requirements in respect of the operation of the equipment. Elenos cannot be held responsible for any damage, direct or indirect, caused to persons or property, through the use of the equipment supplied.

For the replacement of spare parts under warranty, specify the model and serial number as well as a description of the part and the part number, where known.

SUSPENSION OF DELIVERIES

- When any condition of supply is contravened, even in part, or there is any variation in the purchasing company's trading name, in its constitution or its commercial capacity, even in respect of third parties, Elenos reserves the right to suspend further deliveries.
- Independently of the above mentioned circumstances, the seller reserves the right to reduce its limits of exposure to the purchaser in the event of a change of general market conditions or any facts or circumstances such as would influence the normal business activities of Elenos.

CLAIMS AND DISPUTES

- The purchaser must examine the goods immediately on arrival and, in the event of any defects, must give written notice within eight days.
- Late claims will not be accepted.
- Claims will be rendered void, without exception, by law, in the event that payment has not been received for the goods in question.
- Elenos will accept claims for defective goods only if the purchaser has complied with the conditions of operation and storage and if notice of the claim is received within the given deadline.
- In the case of a legitimate dispute, Elenos reserves the right to decide whether to concede a reduction in the sales price, or to change the non-functioning component free of charge.
- All rights of compensation are excluded to the limits laid down by law.
- In the event that exclusion is not possible, the compensation for damages will be limited to the sale price of the non-functioning equipment.

EXEMPTION OF RESPONSIBILITY

- The purchaser is obliged to observe all legal and safety requirements in respect of the operation of the equipment.
- Elenos cannot be held responsible for any damage, direct or indirect, caused to persons or property, through the use of the equipment supplied.
- This also applies to industrial patent rights, which could impede the sale of the goods.

EXPORT BAN

- With the exception of a written agreement, the purchaser is prohibited from exporting goods supplied by Elenos or making goods available to persons or companies who will export them.

PLACE OF JURISDICTION

- In the event of legal disputes, the place of jurisdiction will be the Tribunal of Ferrara.

ELENOS S.r.l. BROADCASTING EQUIPMENT
Via G. Amendola 9 - 44028 Poggio Renatico (FE)
Tel. +39 0532 829 965 - Fax. +39 0532 829 177
E-mail: info@elenos.com Web Site: <http://www.elenos.com>

RETURN INFORMATION POST CARD

To obtain a two (2) years guarantee, mail the following registration card and the intervention recording card by registered mail. The guarantee will be extended starting from the mailing date of the card.

The extension to 2 years is also valid if, during the last month of the first year of guarantee, the intervention recording card on page 113 is faxed or sent by registered mail to ELENOS correctly filled in.

The post card must be filled in (in block letters) in every part and sent to:

ELENOS S.r.l.

Via G. Amendola 9 – 44028 Poggio Renatico (FE) – Italy

Note: If all required data are not sent, the guarantee will not be extended to 2 years

☐.....

Nome / Name:

Cognome (del cliente) / Surname (of the customer):

Azienda / Firm:

Apparecchio acquistato / Model purchased:

Indirizzo completo / Complete address:

E-MAIL:

Tipo di apparecchi collegati all'apparecchio ELENOS:

Machines connected to the ELENOS apparatus:

Timbro e firma del Cliente
Customer stamp and signature