

INSTRUCTIONS FOR USE AND ASSEMBLY OF THE FRB 6, 15 & 40 WATT AMPLIFIERS

Soldering the six, fifteen or forty watt amps is done best with a 25-30 watt pencil iron with a 1/16" tip. Solder larger components first. It is especially important is to avoid higher wattage irons on the transistor and small surface mount capacitors. Surface mounting of the larger components can be achieved best by melting some solder on the pad at the point where the component will go. Then heat the solder and place the component in position and let the solder grab that one lead. This will hold it in position so the other lead can be soldered. If needed, retouch the first lead with a bit more solder.

The mica capacitors should have the leads bent out 90 degrees, so that there is 3/16ths of an inch between the bend and the capacitor body. See the diagram on the parts placement drawing. The inductor coils have long leads that should be cut down to around 1/8 of an inch. Next, solder the remaining smaller components in a similar fashion. With coils made from enamelled wire, scrape the coating from the wire before soldering. It will not solder with coating on the wire. The small surface mount (SMT) capacitors require a light touch, do not overheat. With the soldering iron touching the pad, melt a small drop of solder where one side of the SMT capacitor will go. Then, using tweezers while heating that area of the pad, push the SMT capacitor into position, keeping it flat. Position is so is centered with one side connecting to the pad and the other side touching the ground area of the circuit board. Now, heat the ground area around the SMT capacitor and touch it with a bit of solder so it flows onto the lead of the SMT capacitor. When finished, scrape off and wipe away with an alcohol swab any rosin between the pads and the ground part of the board or other pads.

When mounting in a box, remember that the transistor needs to be bolted directly to the heat sink so cut a hole in your box large enough for the transistor to go through. The transistor should also get some silicone heat dispersing compound between the transistor and the sink. When using the brick enclosure mount the board to the bottom of the brick and the transistor to the flat portion, mounting holes have been drilled for this. Mount the circuit board first then the transistor which is soldered in place only after it has been mounted to the heat sink.

For the 40 watt transistor and amplifier Use the #4 bolts and 4-40 nuts supplied to mount the transistor to the heat sink. When the transistor is placed into position, put a ground lug under the head of each 4-40 bolt before inserting them into the heat sink so the lug will come to rest on the top of the mounting flange of the transistor. As the bolts are tightened down hold the ground lugs so they stay positioned on the ground area of the heat sink, do not let them touch any other pads. Do not overtighten the bolts, when you see a thin film of heat sink compound beginning to spread out from under the mounting flange, it is tight enough. Evenly tighten the bolts. Then solder the leads of the transistor to the pads and the solder lugs to the ground area.

For the 6 & 15 watt transistor, trim the leads to one half their original length. Position the transistor so it is very close to the board. If you are using the brick enclosure, a hole will have already been drilled for the mounting tab of the transistor. Use one #4 bolt and nut to mount the transistor to the heat sink, spread a thin film of heat sink compound on the bottom of the transistor first. Observe the same procedure above in regards to tightening of the bolt. Then solder the leads to their respective areas on the circuit board. The middle lead is soldered to the ground area.

At this point the amplifier should be ready for testing and tuning. Prior to applying any power to the unit check continuity with a DVM (digital volt meter) or something similar. First, check continuity between the positive voltage pad and ground, there should be no continuity. If there is, you have a short somewhere between voltage and ground, look for a solder bridge. Next, check between the RF output pad and ground, there should be no continuity. Look for where the short is if there is continuity. Then go to the rest of the pads on both the output side and the input side. Again there should be no connection between ground and those points. Finally check the RF input pad for the same condition.

Now that you have checked out the board for shorts it is time to prepare for dynamic testing and tuning. At this time you should have a working and tested 1 watt PLL exciter ready to go. Please note: the 6 watt amplifier requires only 200 milliwatts to drive it. Three resistors are provided to create an attenuation to reduce 1 watt or so of input power to 200 milliwatts. The RF output is connected from the

PLL transmitter to the input of the 6, 15 or 40 watt amplifier with about 6-8 inches of RG174 coaxial cable. Solder the center conductor to the RF input pad and the outer shield braid to ground. Hold the braid shield with needle nose pliers to prevent overheating the braid section which touches the insulation of the inner conductor. If overheated, it will melt into the inner conductor resulting in an output short. The other end should have already been attached to the PLL exciter.

Using a short cable of RG8x with PL259 plugs on both ends connect the output of the amplifier to the input of a power/SWR meter. Take another cable and connect the output of the meter to a 20 watt dummy load for the 6 or 15 watt amplifier and a 50-100 watt dummy load for the 40 watt amplifier (if you have an inline frequency counter connect it between the meter and dummy load). If you have a frequency counter with a probe, place the probe near the output of the transmitter next to the SO239 connector.

You are now ready to tune and test the amplifier. Be sure to set the PLL transmitter board on an insulated surface next to the amplifier enclosure. Attach power supply leads from the DC power source to both the amplifier and PLL transmitter. At least 18 gauge wire should be used for the connection from the power supply to the amplifier. Before applying power adjust the bias control to the minimum position. One lead of the 10K variable resistor is connected to ground, rotate the control all the way toward that lead. Use a plastic tuning tool for this or a plastic screwdriver. A tweak tool is available from FRB.

Now, apply power. You should see at least 1 watt for the 6 watt amplifier, 2-3 watts or so for the 15 watt amplifier and 10-12 watts for the 40 watt amplifier. Using the tweak stick, slowly increase the bias by turning the 10K variable resistor. You should see full power at some point, do not exceed 40 watts or 15 watts.

After completing the tuning and testing process your amplifier should be ready to go. Proceed to mount the PLL board on the metal plate which slides into the enclosure and permanently hook everything up. Run the positive voltage lead from the PLL board to the red banana jack and solder it in place. There should be enough slack to allowing sliding the metal plate back to expose the amplifier board beneath it. Do the same with the ground lead from the PLL board. Audio connections can now be made to the other end plate, follow the directions which come with the PLL board. Once everything is connected and in place, test the unit again for proper operation. Make sure the voltage and ground connections are correct before applying power. If everything checks out you can slide the lid into place and attach the audio input end plate and the remaining two screws at the output end plate as well.

When operating the unit be sure to have the heat sink fins pointing up, failure to do so might result in damage to the output transistor. A muffin fan blowing extra air on the unit will ensure a long life for the transistor especially in warm or hot conditions.

Finally, do not operate this unit on the air without a filter.

Assembly Instructions for the FRB 6 & 15 Watt FET FM Watt Amps

- 1.) Orient the circuit board with the diagram
- 2.) Use a narrow chisel tip 25-30 watt soldering iron for assembly
- 3.) All the small parts are taped onto one sheet of paper
- 4.) Begin assembly with the surface mount capacitors (SMT) (non-leaded components)
- 5.) Remove one component at a time from the paper, begin at the input side
- 6.) Create a small puddle of solder on the pad where the component is being placed
- 7.) Use a pair of tweezers to hold the capacitor in position
- 8.) Place the capacitor in the correct position as indicated by the diagram. Heat the pad and draw the solder puddle toward the SMT component so the solder flows onto metal lead area on the component
- 9.) **Do not overheat**, this will lead to failure of the component
- 10.) Go to the other side of the component which in many cases will be the ground plane of the circuit board.
- 11.) Heat the area next to the capacitor, apply solder & draw the puddle to the end of the capacitor
- 12.) Soldering surface mount components takes a bit of dexterity and skill. The resulting joint should look like this:



- 13.) Continue to solder the surface mount capacitors to the circuit
- 14.) After this, solder the leaded components to the board, start with the capacitors, **do not solder the transistor in, however.**
- 15.) Keep the leads short and form them like this:

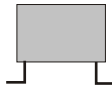

- 16.) When you get to the coils and chokes, form the leads like above and scrape the enamel from the ends of the red wires that will be soldered to the pads.
- 17.) Be sure to orient the 78L05 regulator properly, flat, marked side toward the center of the board.
- 18.) Observe correct orientation on the electrolytic capacitor, negative lead to ground area.
- 19.) The amplifier board is mounted to the heat sink with 4 #6 self tapping screws.
- 20.) Place the board flat on the heat sink (brick enclosures if ordered along with the amp kit come pre-drilled) and mark the hole locations with sharp tip marker (fine tip sharpie).
- 21.) Center punch the hole marks with a center punch (or a nail and hammer), this prevents the drill bit from walking.
- 22.) Drill out the mounting holes with a 1/8" drill bit.
- 23.) Place the amplifier board on the heat sink to check alignment of the mounting holes.
- 24.) Place the board down carefully and align the mounting holes with the holes in the heat sink.
- 25.) Take the #6 self tapping screws and insert them into the holes. Lightly tighten the screws.
- 26.) Trim the leads of the transistor to about 1/4 inch beyond the thick portion of the leads.
- 27.) Grasping the transistor by the mounting flange, place it against the board.
- 28.) With the transistor oriented properly, align the leads with the three pads.
- 29.) Position the transistor so that the three leads are perfectly centered on the circuit board traces

- 31.) The transistor leads should be slightly above the surface of the circuit board
- 32.) Hold the transistor flat in position and flat against the heat sink
- 33.) Mark the center of the flange mounting hole with a fine tip marker
- 34.) Remove the transistor from the board.
- 35.) Remove the board from the heat sink.
- 36.) Center punch the mounting hole for the transistor
- 37.) Drill out the hole with a 1/8" bit.
- 38.) Deburr the hole.
- 39.) Mount the board on the heat sink, do not tighten the screws all the way down just yet.
- 40.) Spread a thin film of heat sink compound on the bottom of the flange of the transistor
- 41.) Position the transistor per lines 27-30
- 42.) Take one 4-40 by 1/2" bolt and insert through the flange mounting hole.
- 43.) From the other side of the heat sink place 4-40 nuts on the bolts and finger tighten
- 44.) Check the alignment of the transistor per lines 27-30, it needs to be perfectly aligned
- 45.) You may have to wiggle the board or transistor slightly to achieve alignment.
- 46.) Check for proper alignment, tighten down the #6 screw.
- 47.) Lightly tighten down the transistor, do not over tighten, go back and forth from one bolt to the other.
- 48.) When you see the heat sink compound begin to squeeze out from the flange, it is tight enough.
- 49.) Now, solder the leads of the transistor to the areas they are contacting on the board
- 50.) Do not use too much solder.
- 51.) Puddle the solder first on the pad and then draw it toward the transistor lead.
- 52.) Apply the solder and let it flow between the pad and transistor lead. Then solder the copper tabs.
- 53.) Remove the solder flux from the pad areas with alcohol and a small stiff brush, an old toothbrush
- 54.) The next step is to connect the voltage and ground wires to the board
- 55.) Use #18 stranded insulated wire for these connections
- 56.) Measure the length needed to connect from the voltage pad of the circuit board to where the red banana socket is mounted on the panel
- 57.) Cut the red wire to length and strip about 1/4" of the insulation from the ends
- 58.) Route the wire so it runs parallel to the edge of the board, not across it
- 59.) Solder one end to the voltage pad and the other end to the tab on the red banana socket
- 60.) Repeat the process with the black wire.
- 61.) Solder one end to the banana jack and the other end to the circuit board ground area.
- 62.) The RF output pad is connected to the SO239 socket with a length of RG213 coaxial cable
- 63.) Carefully strip about 3/4 inch of the outer insulation from each end of the coax
- 64.) Unbraid the outer conductor from each end and twist into a tight wrap, then carefully strip about 1/4 inch from the end of the inner conductor - do not nick the inner conductor. Lightly tin both the inner conductors and braid shield wires.
- 65.) Puddle a bit of solder on the output pad of the circuit board, grasp the inner conductor of one end of the coax with a pair of needle nose pliers and solder it to the pad. Then grasp the braided shield wire with the pliers and solder it to the ground area next to the pad. Be sure that braid wire does not contact the output pad.
- 66.) Grasp the inner conductor of the other end of the coax with a pair of needle nose pliers and solder it to the center pin of the SO239 connector, some extra heat will be required. Then grasp the braid with the pliers and solder to the solder lug on the SO239 connector.

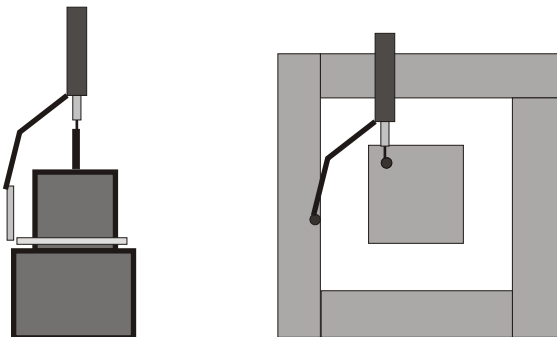

- 67.) The last remaining connection is to the input pad of the amplifier. The 6 & 15 and 15 watt amplifiers require only 200 milliwatts of drive. The three resistors shown on the diagram attenuate a nominal 1 watt input to 200 milliwatts. It is essential that you use the attenuator pad comprised of these resistors when using a 1 watt source.
- 66.) Usually the input will be coming from a 1 watt PLL exciter, do not exceed 1.5 watts.
- 68.) If you are using our brick enclosure, the PLL exciter will be mounted on a slide plate directly above the amplifier with its voltage leads connected to the red & black banana sockets.
- 69.) Use a short piece of RG174 coax to connect from the output of the 1 watt PLL to the input pad of the amplifier, same procedure as before.
- 70.) If you are using an external exciter to drive the amplifier, you will connect the input pad to the power input SO239 connector with a short piece of RG174 coax.
- 71.) Double check all the connections, use a continuity test to make sure there are no shorts on the input and output traces of the amplifier.
- 72.) Connect a dummy load of sufficient capacity (20 watts continuous) to the output connector of an RF power meter. Use a short coax jumper to make the connection.
- 73.) Connect the output of the amplifier to the input connector of the RF power meter.
- 74.) If you are using an external amplifier to drive the amplifier, connect it to the input of the amplifier.
- 75.) If you are using an internal PLL exciter, be sure it is working correctly and the output does not exceed 1.5 watts. Turn the 10K bias pot so that the wiper is at ground side.
- 76.) Once everything is connected properly it is time to test the amplifier.
- 77.) Connect your power supply, 12-14 volts DC - observe correct polarity.
- 78.) Turn on the power supply, be certain the unit is connected to the power meter & dummy load.
- 79.) With 13.8 volts DC and the bias turned down, the amplifier should put out about 10 watts
- 80.) If there is no output or the transistor is getting excessively hot, turn everything off and check all the connections - bad solder joints are the usual culprits.
- 81.) If everything is ok, then proceed to turn everything off.
- 82.) Turn the unit back on, and increase the bias voltage by turning the trimpot CW, you should be able to reach either 6 or 15 watts, do not go beyond 6 or 15 watts.
- 83.) When the amplifier is put into operation proper cooling is necessary. Be certain that the heat sink fins are point up and are not obstructed.

FRB 6 Watt FET FM Amplifier Parts List

C1 – 470 pf ceramic or mica capacitor	1
C2 – 27 pf 1206 surface mount capacitor	1
C3 – 150 pf 1206 surface mount capacitor	1
C4 – 82 pf 1206 surface mount capacitor	1
C5 – 33 pf 1206 surface mount capacitor	1
C6 – 100 pf mica capacitor	1
C7, C9, C11 - .001 uf monolithic capacitor	3
C8, C10, C12 - .1 uf monolithic capacitor	3
C13 – 47 uf electrolytic capacitor (observe correct polarity)	1
L1, L2 – 4 turns #18 wire, .25 diameter	2
L3 – 2 turns #18 wire, .25 diameter	1
L4 – 3 turns #18 wire, .25 diameter	1
L5 – ferrite bead on wire	1
L6 – wide band rf choke	1
IC1 – 78L05 voltage regulator	1
Q1 – RD06HFV1 FET RF transistor	1
R1 – 10K trimmer	1
R2 – 150 ohms ¼ watt resistor (brown, green, brown)	1
R3, R5 150 ohms ½ watt resistors (brown, green, brown)	2
R4 – 39 ohm ½ watt resistor (orange white black)	1
RF Connector, SO239	1
Banana Plugs, 1 red, 1 black	
Banana Sockets, 1 red, 1 black	
Coax, 8" RG174	2
Hookup wire, 8" twisted pair #24	1
Heat sink compound packet	1
Circuit Board	1
Bolts, #4 1/4" long	5
Lug terminal	1
Nuts, 4-40	5
#6 Self tapping screws	4

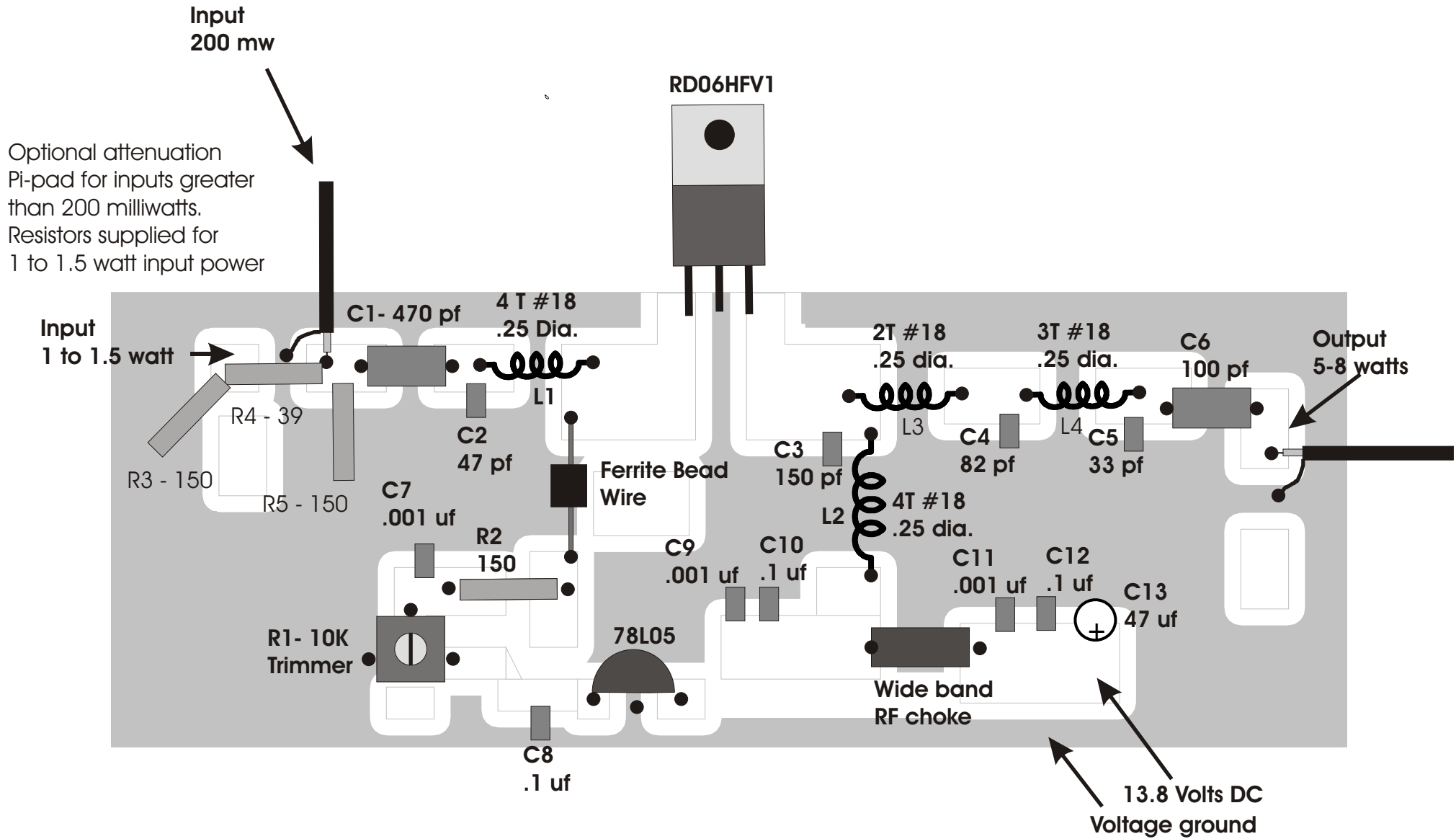

**Free Radio Berkeley
6 Watt FM FET Amplifier
10-14-2006**