

- NA 501 -

500W FM POWER AMPLIFIER

USER AND MAINTENANCE MANUAL

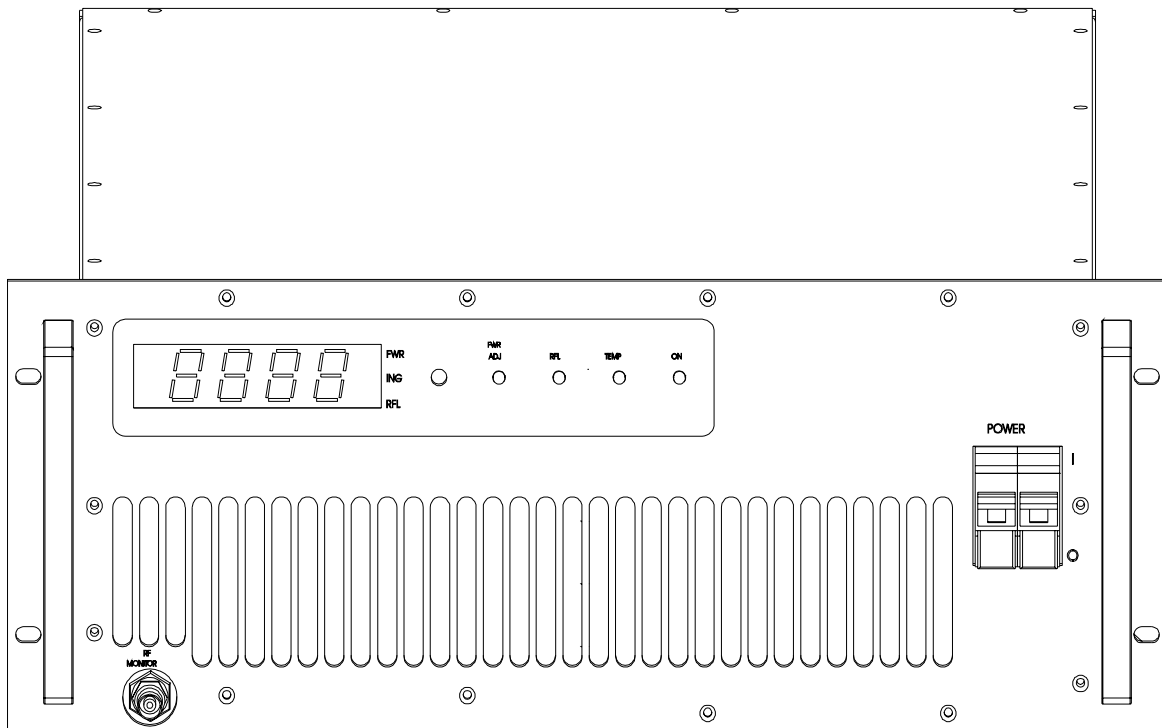

CONTENTS

1	GENERAL DESCRIPTION	3
2	TECHNICAL FEATURES	4
2.1	FRONT PANEL COMMANDS AND SIGNALLING	4
2.2	THE REAR PANEL AND THE CONNECTIONS	5
2.3	TECHNICAL SPECIFICATIONS	6
2.4	I/O REMOTE CONTROL SPECIFICATIONS	6
3	INSTALLATION AND USE	7
3.1	FOREWORD TO INSTALLATION	7
3.2	PLACING THE UNIT	8
3.3	WIRING INTO THE MAINS	9
3.4	ANTENNA CONNECTION	9
3.5	LF CONNECTION	10
3.6	OTHER RECOMMENDATIONS	10
3.7	OPERATION	12
3.8	POSSIBLE MALFUNCTIONS	13
4	SERVICE AND MAINTENANCE	14
5	Warranty	14
6	SERVICE MANUAL	15
6.1	SYSTEM DESCRIPTION	15
6.2	INTERNAL DESCRIPTION	16
7	REPAIR AND REPLACEMENT OF DAMAGED MODULES	21

DRAWINGS

A.1	NA 501 amplifier front & top internal view (D1067)	
	NA 501 amplifier, rear and bottom internal view (D1068B)	
A.2	NA 501, general electric diagram, ver. 220-240Vac (E0893)	
	NA 501, wiring diagram (E0895)	
	NA 501, power supply front-end (E1003)	
	SRFB1K0AL2, RF control display, RF controls & measures board and component layout (E0894)	
	SRFB1K5ALM, 48V/40A SMPS regulator module diagram and layout power and control section	
	NA 501, 500W RF amplifier assembly electric diagram (E0857)	
	SRFB1K0IN, 2-port RF input splitter diagram and layout (E0858)	
	SRFB1K0PB, 2-port RF output combiner & LPF diagram and layout (E0859)	
	SRFB500W, 500W amplifier module diagram and layout (E0764)	
	SRFB500W, 500W amplifier module - component layout	

NA 501

500W FM POWER AMPLIFIER

1 GENERAL DESCRIPTION

The NA 501 is a highly integrated broadband solid-state Mos-Fet FM amplifier of 500W rated power, fitted in a 4 unit 19" rack, which do not require any specific calibration to operate in the 87.5 ÷ 108 MHz frequency range.

Its compact size, high efficiency, wide mains range acceptance, low maintenance requirements and broadband construction, make this amplifier ideal in medium power repeaters, in unattended posts, in N+1 systems and as a reserve.

Its sturdy, modular mechanical and electrical construction guarantees a high MTBF and an easy maintenance. The modules are easily identifiable and inspectable with few interconnections each with the other, through multi-pole connectors.

The nominal RF output power is obtained over the full FM range with a mere 8W drive and is particularly stable against time, temperature and frequency variations being ALC regulated, with a front panel adjustment. The output power may be varied from a minimum level to the nominal level and the frequency varied over the full FM range, without retouching the drive power or any other adjustment than the ALC control.

The output stage has a reverse intermodulation figure, which is lower than standard bipolar construction, due to the all Mos-Fet design and approaches that of tube equipment.

A simple metering and alarm section completes the amplifier, permitting an easy check of the functioning with few, unambiguous readings. Power readings and control are externally available on a remote I/O port, for an external controller. A suitable one may be supplied on request to permit full remote control of the Unit from the studio or another service centre.

The whole assembly is designed in accordance with the CCIR, FCC and tighter international norms and conforms to the recent, strict **CE** requirements for EMI susceptance and emission.

This equipment complies in particular to ETSI EN300.384 and EN 300.447 Broadcast and EMI/EMC standards, EN60065 and EN60215 safety standards and FCC parts 73 & 74.

2

TECHNICAL FEATURES

2.1 FRONT PANEL COMMANDS AND SIGNALLING

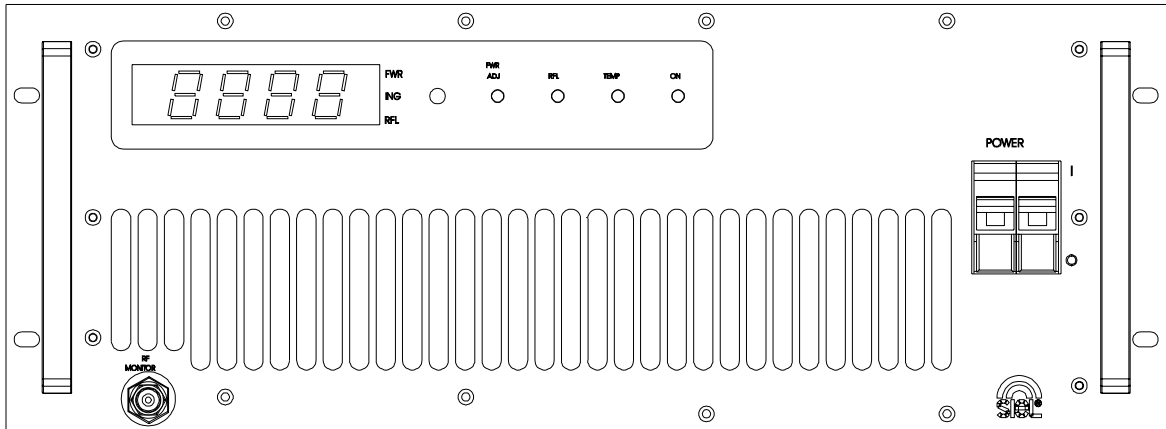

The front control panel carries the power on switch, the control meter, some alarm warning led's and a RF monitor connector. On the bottom side, a gridding on the panel permits the output of the ventilation air.

At the RF monitor output, BNC type, a sample of the output power is available which is attenuated 54dB typically (i.e. +6dBm @ 500W output). Even if this output is fairly flat vs. frequency, it is not suggested to use this for accurate harmonica analysis.

The switchable meter permits the reading of the most important operating parameters, i.e. the forward and reflected power (500W f.s.) and the regulated and unregulated power supply voltage (300Vdc f.s.).

The 2 led's light only in case of failure. The meaning of these led is summarised on the following table:

LED	MEANING
VSWR	High RF output reflected power (> 50-60 W)
TEMPERATURE	High internal temperature, probably due to high environment temperature or failure of the ventilation system.

Table 1: warning led meaning

2.2 THE REAR PANEL AND THE CONNECTIONS

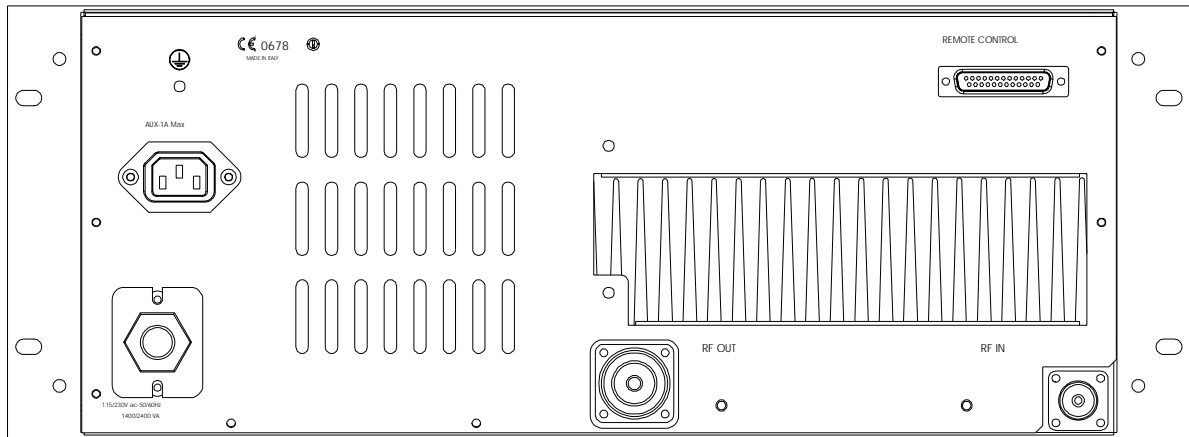

The rear panel allocates the RF power and the I/O ports in addition to the mains power cord and fuse, the earthing screw and an auxiliary mains socket on some models. The power cord is not removable. If it is required a longer cable than that provided in the factory (roughly 2 meters long), a suitable 3x 1.5 mm sq. power cord may easily replace the original one. The fuse has a different rating for 115 or 230V ac operation: be sure to adopt the right type for your mains network

The Antenna output is brought out on a type "N" connector, the input connector is also a "N" type. A remote I/O port is available on a SUBD 25 poles, female connector.

The exhaust air output opening must not be obstructed during operation: wide room must be provided during installation to permit a sustained ventilation air flux. It is not permitted to insert the equipment in a closed rack without a suitable external air extraction system.

An auxiliary IEC-320 female type mains outlet is provided, which is powered only when the amplifier is on, to supply the exciter. No fuses other than the general fuses (16A) are inserted on this line. Limit the power absorption from this outlet to low levels, i.e. 100W / 1A max.



Setting the mains voltage for 115 or 230V operation requires to gain access to the inner of the equipment, removing the top cover. Be sure to remove the power cord from mains to avoid direct exposure to hazardous mains voltage, which are always present on the fuses and the input board, even with power on switch in the off position.

2.3 TECHNICAL SPECIFICATIONS

@ 1kW RF output if not otherwise specified

- Frequency range: 87.5 ÷ 108 MHz
- RF input power 8W nom., 10 W max
- RF output power 500 W ±0.5 dB

- RF input/output impedance: 50 Ω
- RF input connector: N
- RF output connector: N
- RF monitor connector: BNC

- Harmonic and spurious emissions: < -70 dBc
- RF monitor attenuation: 54 dB, typ.

- Max total current handling capability on the auxiliary socket: 1A @ 230 Vac, 100Wmax, not fused

- Mains supply requirements: 115 / 230 Vac 50/60 Hz <950W (1250 VA)

- Operating temperature range: 0 ÷ +35 °C recommended, -10 ÷ +50 °C max

- Dimensions, not including the handles: 483 x 177 x 535 mm (W x H x L)
See drawings
- Weight: approx. 66Lbs (30 kg).

2.4 I/O REMOTE CONTROL SPECIFICATIONS

A remote I/O DB25 female connector, located on the rear panel, makes available 3 analog lines to permit remote control and surveillance of the equipment as detailed:

Pin	Line	Range/use
1,3,21	ground	common
9	Reflected Power	0÷5V vs. 0÷550Wout Zo=10kΩ (4 V typ. @ 500W)
10	Forward Power	0÷5V vs. 0÷550Wout Zo=10kΩ (4 V typ. @ 500W)
13	Power control	External RF output control. 0-5V to full scale, low impedance

The remote I/O signal and control DB25 female connector, on the rear panel

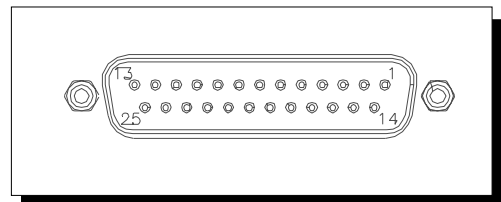

3

INSTALLATION AND USE

3.1 FOREWORD TO INSTALLATION

Although in most cases no special instruments are required, have skilled personnel install the Unit. To make best use of the Unit's capabilities and prevent damage to the unit, comply with the recommendations throughout this manual.

When in doubt, or if any technical problems should arise during the installation procedure, Nicom strongly recommend the Unit not to be tampered with in any way by unskilled personnel and will be glad to supply qualified after-sale service.

As a rule, the user should not have access to the inside of the Unit for normal installation and use. Tampering with the factory settings makes the warranty void and might also affect Unit' performance, causing costly damage.



NO ADJUSTMENT OR INTERNAL PRESETTING IS REQUIRED FOR NORMAL OPERATIONS. THE UNIT SHALL BE PROPERLY GROUNDED AND BE OPERATED WITH ALL THE COVERS CLOSED TO PREVENT ELECTRICAL HAZARDS IN OPERATION AND FULLY COMPLY WITH CE EMI AND SAFETY REQUIREMENTS.

NEVER TOUCH THE INSIDE OF THE UNIT WITHOUT FIRST DISCONNECTING IT FROM THE MAINS. DANGEROUS AC, DC AND RADIO-FREQUENCY VOLTAGES ARE PRESENT INSIDE AND BECOME ACCESSIBLE WHEN THE COVERS ARE REMOVED.

———— MAINS VOLTAGE MAY KILL ————

3.2 PLACING THE UNIT

Install Unit in a dry, sheltered but well-ventilated room away from dust, moisture, insects and vermin (mice).

Place Unit as close as possible to the antenna to prevent excessive power loss in the cables. If this is not feasible, use antenna cables of suitable cross-section.

Room size shall be such that the Unit can be placed in an upright position and that technical personnel can easily carry out routine or extraordinary maintenance. The minimum recommended size is 2.5m x 2m, and 2.2m high when there is no other broadcasting or support equipment nearby.

The room must be ventilated to ensure that the inside temperature never exceeds 35°C. Even if 45°C is the max. allowed temperature: it is anyway suggested not to approach to this limit.

This condition cannot generally be met when the exhaust cooling air is not pushed outside and is fed back into the room. This is even truer if more than one Unit is installed in the same location. An efficient ventilation system is thus required in the room. Air exchange in the room shall have a minimum flow-rate of 500 metres cubed per hour or more.

If the Unit is fitted in a rack system, the back door of the rack cannot usually be fixed in place. If a completely closed assembly is needed, a suitable ventilation extraction unit must equip the system. To aid air ducting, an optional flange may be retrofitted on the ventilation outlet to which a duct can be attached to convey hot air outside. In this case remember that the NA 501 internal fans are low-pressure units: some sort of external air extraction blower is than imperative on the exhaust air duct.

Vents in the walls and any other openings shall be fitted with a metal grating to keep rodents out, and with a dust filter. Make absolutely certain that no water can seep through the vents or the air exhaust duct or antenna-cable grommet, and that the floor cannot be flooded during heavy rainfall. If not impeded by proper air filtering, insects in some location may be conveyed in the internal heatsink, accumulating on it and finally obstructing it, causing overtemperature alarm.

Even moisture and/or dust, when contained in the air or in the room in excessive quantity, may cause condensation build-up in the amplifier. When the system is periodically switched on and off, this can trigger destructive electric arcs and short circuits and thus cause damage that is not covered by the guarantee.

3.3 WIRING INTO THE MAINS

The NA 501 is powered by a single-phase line. Mains capacity must be at least 2kVA and the nominal voltage is 230Vac. In some countries, where 115Vac is the norm, this voltage must be internally set in the factory or by skilled people before installation.

While the power supply regulator accepts a wide input voltage (190 ÷ 250 Vac), operation near the lower input voltage on high impedance lines must be avoided: if the line drops more than 10 volt at full load, the low line sense circuitry may trigger an oscillating turn-on/turn-off cycle, which is very dangerous. In this cases adopt an external line stabiliser.

The nominal mains input range (190 ÷ 250 Vac) is achieved when the primary side of the main transformer is wired to the 230 V tap. Two other taps, the first one slightly lower (220 V), the second higher (240 V), are available to adjust the input voltage range of ±10 V. In countries were a stable 240V is the norm, it is important to set this tap on the transformer. In this case the allowed voltage range window must be shifted higher to avoid nuisance trip at occasional higher mains voltage. See proper section in the service section of this manual.

To ensure proper operation and comply with the safety regulations, efficient earthing is required. Use the yellow/green lead in the power cable. The cable's neutral lead is blue. Never connect the earth to the mains' neutral lead.

The cable connecting the NA 501 mains input terminal block to the external board should consist of leads of adequate cross-section. Recommended values are 1.5 to 2.5 mm squared.

Do never switch the Unit on without antenna connection, even when no RF drive is on.

3.4 ANTENNA CONNECTION

An "N" output connector is fitted at the back of the amplifier module. It is very important to check that the antenna, the connecting cables and the connectors are suitable for 500W.

The antenna coupler too, should be capable of adequate power; its input connector shall be "N"

3.5 LF CONNECTION

To maximally avoid earth loops, wire the modulation signal line directly on the exciter, with high quality shielded and preferably balanced cable. Ground the shield only on the exciter LF input

3.6 OTHER RECOMMENDATIONS

The ambient temperature shall range between -5°C and $+30^{\circ}\text{C}$ (35°C max. peak). It is advisable to hang a min.-max thermometer on the wall to display any variation.

Air conditioning at $20 \div 25^{\circ}\text{C}$ would obviously be the best solution, but installation and operating costs are generally excessive. Thermal isolation and efficient ventilation with a thermostat-controlled blower are generally the most advantageous solution.

Mains fluctuation and electric discharges due to the weather or nearby industrial machinery may cause significant trouble, especially in mountain areas and in places close to industrial areas. In such cases, it is advisable if not indispensable, to install a protector, and insulating transformer or possibly an electromechanical mains voltage regulator. NICOM can provide all these accessories on request.

Since the total cost of the plant, inclusive of broadcasting equipment, antenna system and installation, is rather high, a certain percentage of the budget should be estimated for buying and installing suitable protection and conditioning facilities as described above.

Depending on location, the share of total cost should be around $20 \div 30\%$; with this expenditure, however, the machinery will operate under optimum conditions, its useful lifespan will increase and, above all, the incidence of accidental breakdowns due to ambient or mains trouble will be reduced.



!! WARNING !!

OPERATION WITHOUT THE ANTENNA OR WITH A FAULTY ANTENNA CONNECTION MAY CAUSE DEGRADATION AND POSSIBLE DESTRUCTION OF THE FINAL STAGE. THIS FAILURE IS NOT COVERED BY THE WARRANTY.

AVOID TO USE TOO POWERFUL EXCITERS. AN INPUT POWER HIGHER THAN 12W MAY PERMANENTLY DAMAGE THE RF TRANSISTOR CAUSING A COSTLY DAMAGE, WHICH IS NOT COVERED BY THE WARRANTY. A STABLE AND PROPERLY REGULATED 20÷25W EXCITER, LIKE NICOM'S NT20 or NT30 ARE THE BEST CHOICE.

NA 501 driven by a typical NICOM exciter generates a very clean RF output. Nevertheless if any strong RF signal, coming from nearby transmitters is coupled to the antenna, it may cause intermodulation in the output transistors and generate spurias. In this case a tuned output filter may be required to remove the problem.

It is mandatory to provide adequate ventilation to the Unit to maintain its internal temperature as low as possible, in the recommended range 5 ÷ 25°C. Even if the Unit may sustain 45°C, and occasionally slightly higher temperatures, its life expectancy will be impaired by high temperature.

As general rule the life expectancy may be halved by each 10°C increase in ambient temperature, over 30°C.

3.7 OPERATION

Check that the antenna, the subsequent power amplifier or a suitable dummy load is connected to the amplifier RF output. If the NA 501 drives a tuned tube amplifier, check that the input of the power amplifier is already tuned on the wanted frequency. Control that the power cords are correctly connected to the amplifier and its driver and both the Unit are off. Before connecting to the amplifier, control that the exciter power is set at zero or a very low level ($<1\text{W}$) and the frequency is correctly set. Check that the exciter output signal is fed to amplifier input, then:

- 1) Switch-on the power-on switch on the NA 501:
 - the switch will glow red.
 - Internal blowers will start.
 - No led should light on.
 - No RF output power should be present.
- 2) Properly position the meter switch to observe the RF output increasing on the amplifier.
- 3) Switch-on the power-on switch on the exciter
- 4) Slowly raise the drive power to the required level, i.e. $8 \div 10\text{W}$.
 - The RF output power should rise from zero to the nominal 500 Watt, if the output power adjustment is set to maximum on the amplifier front panel.
 - No led should light on.
 - As a general rule, the input power must be 20% higher than the minimum level required to the full output power (i.e. 8W if 10W are enough to obtain 500W on the output).
- 5) Control and note for future reference the correct reading of the operating parameters through the internal instrumentation, which must indicate the following values:
 - FORWARD POWER: up to 500W
 - REFLECTED POWER: $< 50\text{ W}$, typ. $0 \div 20\text{W}$
 - REGULATED VOLTAGE: 48V (300V meter range)
 - UNREGULATED VOLTAGE: $140\text{V} \pm 15\%$

Some amplifiers do not permit to read the regulated and unregulated voltage on the internal meter.

The installation of the amplifier is thereby completed. A spectrum analysis is now advisable to assure no spurious products due to internal or external causes (i.e. reverse intermodulation on the final stage) are generated. Nicom wishes you success in your work and remind you that they are always available for further information or to tackle any specific problem.

3.8 POSSIBLE MALFUNCTIONS

No led alarm must be on during regular functioning: following is a list of possible malfunctions causes.

"VSWR" led on

This led turns on when the reflected output power exceeds the 40-50 W threshold. In this case, do not operate the system and check antenna, relevant wiring and connectors.

When the Unit is connected to a successive amplifier, re-tune the latter's input to obtain the smallest reflected power.

This light should never turn on; it might however flash briefly at low power when firstly tuning the input of an NA 501-driven tube amplifier or a cavity band-pass filter.

"Temperature" led on

This led turns on when the internal temperature is excessive. Reduce environment temperature and increase room ventilation. In this case, it is important that the hot air released by the Unit be exhausted.

Control regular functioning of the internal ventilation fans and clean any externally applied dust filter, if any.

4

SERVICE AND MAINTENANCE

Since the NA 501 is cooled by air, it is subject to clogging by dust. Because of the high-quality materials used in their manufacture, if it is installed as set forth under "INSTALLATION AND USE," it will not require special maintenance for quite some time.

A regular service routine, mainly to remove internal dust is suggested over a 6 month to a year rate. Take present that 90% of the air circulation is restricted to the main internal ventilation channel and do not affect the components. Regularly change the ventilation fan, especially in higher temperature environments. A 2-year rate may be prudential: always use the same high quality, ball bearing fan type.

After a few years of continuous service, it is recommended that the Unit be overhauled in the factory or in a specialised laboratory, where the characteristics can be checked against the initial ones and recalibration can be made when needed.

It is also especially important that the power supply be over-hauled when the Unit has been working at high temperatures, over $30 \div 35^{\circ}\text{C}$.

Never change or cause the original settings to be changed when the necessary, complex testing equipment and standard calibration procedure are not available.

5

WARRANTY

Like all NICOM's solid state equipment, the NA 501 carries a 2-year Warranty on all its components with the exclusion of the final RF power module, which may be damaged by faulty output connections.

This warranty is null and void if the Unit is tampered with or if failure is due to improper use, wrong installation or external causes, such as mains overvoltage.

This warranty covers work done exclusively in our laboratories and in those of our agreed representatives.

The goods shall be delivered carriage prepaid to the laboratory and shall be returned freight forward.

This warranty does not cover any consequential damage due to non-operation or faulty operation.

6

SERVICE MANUAL

6.1 SYSTEM DESCRIPTION

3 basic sections compose the NA 501: the RF amplifier box, the power supply and the control and metering section.

The RF section comprises 1x 500W amplifier modules connected through strip-line combiners. All the RF transistors are Mos-Fet type. A low-pass filter with directional coupler completes the section, which is completely screened by a metal box, to comply with EMI requirements. A fully planar design permits an immediate access and inspection to the 2 internal modules.

The power supply comprises a mains transformer, whose output is rectified and filtered and a highly efficient Switch-Mode Power Supply regulator.

The RF control section is built on one small board. It performs RF AGC and protection control; providing metering and an interface to the external I/O port. Both direct and reflected power are displayed and provided as proportional analog signal at the Remote I/O port. Through this port is possible as well to command the RF output power, overcoming the internal front panel regulation.

6.2

INTERNAL DESCRIPTION

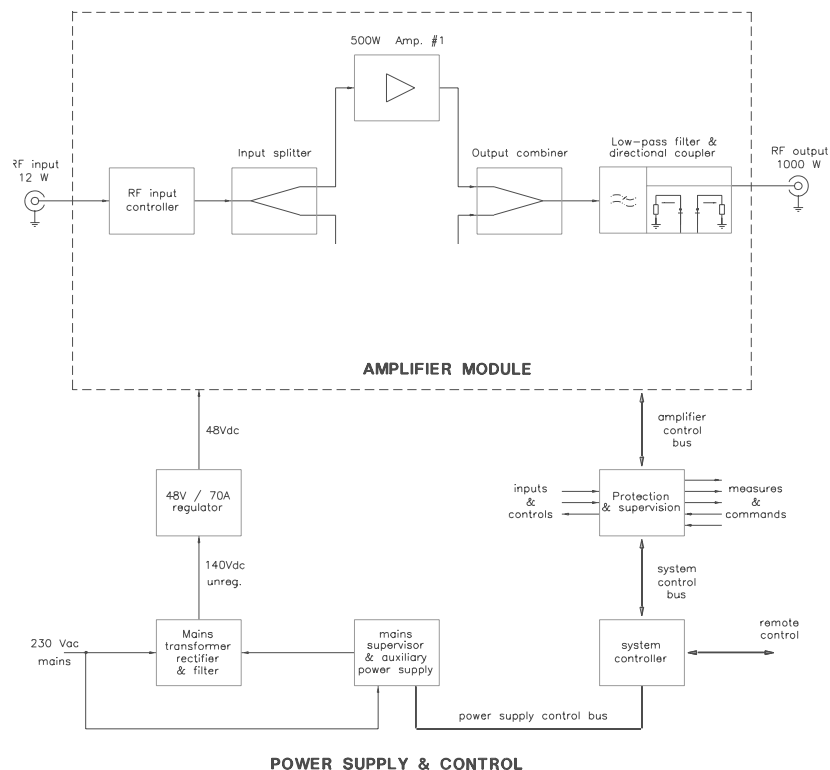

NA 501: Block diagram

The NA 501 amplifier comprises 6 internal different modules/boards plus some spare components, as can be seen in the drawing of the inner contents and in the "General wiring diagram"; both comprised in this manual:

- The power supply transformer, rectifier and capacitor
- The Switch Mode Power Supply regulator
- The RF control and measure board
- The input RF power splitter
- The 500W RF power amplifier module
- The output RF combiner, Low-Pass Filter and coupler

For the detailed description of each module on the following pages, always refer to the corresponding electrical diagram, in the relevant section of the manual.



THIS SECTION IS ONLY AIMED TO GENERAL KNOWLEDGE OF THE UNIT AND FOR SERVICE PURPOSE BY SKILLED PERSONNEL. AS EXPLAINED IN THE PREVIOUS SECTIONS, INTERNAL ADJUSTMENTS ARE NOT REQUIRED DURING NORMAL OPERATION. TAMPERING WITH INTERNAL SETTINGS VOIDS THE WARRANTY, MAY HARM THE UNIT AND JEOPARDIZE THE GUARANTEED PERFORMANCE.

IN ADDITION, MANY MODULES ARE TOO MUCH SPECIALIZED AND DIFFICULT TO REPAIR EVEN BY SKILLED TECHNICIANS AND MUST BE REPLACED IN CASE OF NEED BY BRAND NEW ONES AND POSSIBLY RETURNED BACK TO FACTORY TO VERIFY IF THEY CAN BE REPAIRED.

ANY INSPECTION ON THE MODULES DESCRIBED ABOVE MUST BE EXECUTED WITH THE TOP COVER REMOVED AND OFTEN WITH THE OPERATING UNIT CONNECTED TO THE MAINS. ALTHOUGH MOSTLY OF THE PARTS UNDER VOLTAGE ARE INSULATED AND ARE NOT EASILY ACCESSIBLE, THIS EXPOSES TO THE RISK OF ACCIDENTAL CONTACT WITH THE MAINS VOLTAGE. TO AVOID IT, ALWAYS USE INSULATED TOOLS AND NEVER TOUCH THE SUPPLY TRANSFORMER, THE MAINS SWITCH OR THE MAINS SOCKET WITH MAINS CONNECTED. NEVER OPERATE THE EQUIPMENT WITH THE COVERS REMOVED. REMOVAL OF THE BOTTOM RF COVER MAY LEAD TO IMPROPER FUNCTIONING OF ANY ELECTRONIC MEASURING METER DUE TO HIGH RF FIELD.

--- MAINS VOLTAGE MAY KILL! ---

6.3 The power supply components

The power supply components, other than the boards below described, are very few: mainly the power transformer with a power relay, a bridge rectifier and a power capacitor, which delivers the raw rectified dc power to the SMPS regulator module.

The unregulated dc voltage, nominally 140 Vdc, may range 120 ÷ 170 V. The primary tap on the power transformer is factory set on the 230V input, allowing a mains range approximately 200 ÷ 250 Vac. Should the mains voltage be 240Vac nominally, it is suggested to change the transformer tap to that voltage. If the mains voltage is a stable 215 ÷ 225 Vac, the transformer tap may be left as factory set. Only if there are frequent occasional drops of mains input below 195V and consequent system stops, it is suggested to lower the input tap to 220V.

To do that, the power cord must be disconnected from the mains, the top cover must be removed and the transformer voltage terminals may be accessed.

An USA version is provided with a somewhat different transformer and general wiring (see the appropriate electrical diagram and internal layout). In this version, some jumpers must be preset on the equipment's internal terminal board TB1 to provide 115 or 230Vac operation, if not factory wired. In details these settings are:

220 Vac	1/P3 to 3/P4
115 Vac	3/P3 to 3/P4 and 1/P3 to 1/P4

6.4 The Switch Mode Power Supply regulator

This module performs an efficient regulation of the raw dc input, nominally 140V ±15% to a lower 48V ±1%. Being its efficiency very high, very little heat is produced in the regulation process. The nominal current capability of the regulator is much higher than requested, and approaches 40A @ 48V.

A control I/O connector on an upper daughter board permits a remote control of the regulator

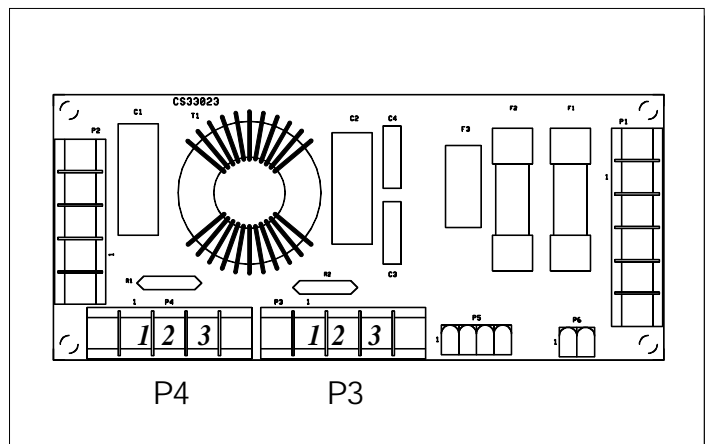

NA 501:
Positioning of the power supply
internal terminal board

by the Unit controller, i.e. output on/stand-by, current and voltage monitoring, status prompting and alert.

A fast 80A semiconductor-grade protection fuse is screwed on the board: it may be fused by the crowbar protection in case of switching transistor damage. If this happens a first attempt to replace the fuse may be accomplished, after having verified the integrity of the power transistors. Usually something is broken so causing the fuse blow-up.

Reparation of this module in the field is very difficult if any component other than the fuse and/or a power transistor failed. It is suggested to substitute the module with a new one and send back the damaged unit to the factory for inspection and possible reparation.

6.5 The RF control and measure board

This small board carries all the circuitry to control and protect the RF amplifier stage. Let us consider its various loops.

Two identical buffers, IC4a and IC3a, insulate and amplify the direct and reflected signal detected on the RF output coupler, with different gain. The main direct power regulator loop is built around the subsequent IC4d op-amp, which compares the sensed signal with the preset power level on RT5. Adjusting this trimmer, the RF output power may be varied to values different from that factory preset. Never exceed a safe 500W on RF output, even if the amplifier is usually able to easily threpass this limit, to have some safety margin. The output of IC4d constitutes the AGC line, which is buffered by IC5 to drive the RF transistor gates. Both the two sections of IC5 are in parallel to increase the current capability of the external AGC line.

The reflected power protection is managed by IC3c, which compares the reflected sensed signal to a fixed threshold, which is set to 40/50W, as determined by R35 and R36. The output of IC3 adds on the internal AGC line though D14. The action of this circuit is proportional: i.e. the output power is continuously decreased till the fraction which is reflected back no more exceeds the safe maximum level. There is no RF complete switch off even with severe load mismatch.

Both direct and reflected signal lines are conveyed to the remote connector through insulating 10kohm resistors

The temperature protection on the output stage is performed by IC4b, which trips when the temperature sense line crosses its preset threshold, completely disabling the RF output. The temperature sensor is mounted on the heatsink, near the RF transistors, and is constituted by a precise PTC resistors, which varies its resistance accordingly to the temperature.

On this board a small negative rectifier and a regulator (TR5) provides the negative bias to completely disable the RF power, if needed. The positive regulator TR4 derives the positive 11.3V board supply from the +48V regulated line.

6.6 The input RF power splitter

The purpose of this simple board is mainly to divide the input RF drive power in two identical signals, one for each power amplifier module, providing a good insulation between each output port (>20 dB, typ. 23 dB minimum on the whole FM band).

This is done by a Wilkinson type printed coupler, followed by the balancing resistor array R21 ÷ R24.

A directional coupler senses the input RF level and RT1 is regulated to provide the overdrive protection circuit trip at the right maximum input level. The board supports also the direct (or forward) and reflected detector sensitivity trimmers, whose input comes from the output board.

Two additional lines support the RF module bias (or AGC) line and the temperature sensing PTC thermistor.

6.7 The RF power amplifier module

This module is built around a couple of "Gemini type" Mos-fet transistors each one forming a 300W push-pull amplifier.

Discrete Wilkinson-type couplers equip both the input and the output module section, doing the job of dividing and recombining the input and output signals, providing a suitable insulation between the transistors.

A small balancing resistor R1 is mounted on the input splitter, while a much bigger resistor R14 is mounted in the output combiner.

A group of C, R and L RF decoupler and dampening components are mounted on the positive supply line of each amplifier, plus a small value resistor, R12 and R13, for possible separate current detection of each supply leg.

The gate bias is separately adjusted through R15 and R16 on each section. Do not tamper the factory bias preset values!

The full power output of the whole module exceeds 600W, to provide some room for coupling losses on the combining stages of higher power amplifiers, like the same NA 501.

6.8 The output RF power combiner, LPF and coupler

This module is symmetric to the input power splitter and is another printed Wilkinson coupler, whose power management capability is obviously much higher than the input board. In this case the power balancing resistors are high power devices, whose centre connection is referred to ground through an inductor, which discharges any static electricity on the antenna up to a relevant amount of power.

The power combiner is followed by a printed low-pass filter, which attenuates the harmonic products generated by the amplifiers.

3 directional sample lines derive two rectified voltages proportional to the direct and reflected output power and a RF signal for external monitoring purposes.

The NA 501 is a high reliability Unit, as much effort was done in the design and development stage to assure the maximum reasonable working margin for each part. Nevertheless, as all Unit which works 24 hours a day for years, some failures are possible, especially in those environments which over-stress the Unit, like hot or dusty or moist places, or subjected to wide mains fluctuations or static discharges and things like that.

In the event of any failure an appropriate analysis must be done to avoid subsequent failures due to faulty ambient conditions. A often underestimate cause of failure is simply a too high ambient temperature or insufficient ventilation. Improving the ambient and system ventilation as suggested in the installation paragraph of this manual, usually fix the problem.

Other obvious causes may be dust clogging and ventilator fan failure. A regular service and maintenance routine will avoid these sources of problems and it is suggested to change the ventilator each two years, even if no damage is still visible, especially at high ambient temperature.

No air pipe must be attached to the ventilator fan output for air ducting, if an external extracting fan is not installed in that system.

In any case, if the amplifier fails, some work must be done on the Unit to fix the problem. With the appropriate spare parts, most of repairing work may be done on site, without need of special tools and often without need of any solder joint.

Not much needs to be said about the general boards and components changing: virtually all of them may be changed in few minutes, without retouching the adjustments. Most of them are immediately accessible or needs a minimum of dislocation of other components and plates. Only the RF boards need a deeper look.

RF boards are delicate modules, which contains some parts as flanged power transistors and resistors which must separately be screwed on the supporting heatsink and may be easily damaged by improper handling. These boards are the 500 W power amplifier modules and the RF output combiner.

Repairs of these modules are usually made in the factory or in a specialised laboratory, if possible at all. If the p.c. board is damaged perhaps only the costly RF active devices may be recovered. Nevertheless, very often this is worthless because, in case of major damages, these parts are internally electrically damaged or degraded.

Repair of the RF modules requires too, at the end of the reparation, a full check of the module's working parameters in a dummy fixture or in a test assembly which are not available even in most specialised laboratories. For these reasons repairs of the modules, specially the higher power amplifiers, is discouraged at the most and the broken one must be replaced by new parts with the

same identical characteristics, fully tested at the factory.

To replace the modules avoiding as much as possible to damage the new part or the old transistors, if not already broken, carefully follow the subsequent steps:

- 1) Remove the amplifier cabinet from the rack, after having disconnected from its rear connectors the RF input and output cables, the power supply and the control cables. Disconnect also the ground cable from its screw.
- 2) To investigate on the damaged parts or to test the reparation, it may be required to externally connect the removed cables and the RF output load to the amplifier assembly in manner to permit inner inspection of the top and bottom of the Unit. If the latter is placed on a small stand aside of the main rack, the internal cables are usually long enough to permit the connections, avoiding extension cables.
- 3) Open the bottom cover of the cabinet and remove the screen from the damaged module(s), if any.
- 4) If the damage is not immediately visible, it may be helpful to measure the currents sunk by each 300W sub-module amplifier. To this aim a low ohmic value shunt resistor is inserted in series to the 48V power supply of the module's subsections (R12 and R13, 10m Ω). To measure the current sunk, the amplifier assembly must be completely connected and powered with and without RF. A sensitive, RF proof, digital voltmeter must be used to measure the voltage across the shunt resistors, which vary from nearly 1 mV at no load to 100 mV at full power.
Take care: most of low quality digital or analog meters are not able to do this reading, because they are affected by the high RF field and their reading is completely meaningless!
WARNING: great care must be paid not to accidentally short-circuit the resistor leads to the ground with the voltmeter probe tips, during the measurements!
- 5) When properly functioning at full power, each module 300W subsection will sink 8 ÷ 10 Amperes, i.e. 80 ÷ 100 mV across the shunt resistor. The absorption must be balanced $\pm 10\%$ around the mean value on each amplifier. A lower or higher value may mean a module failure.
- 6) Remove the power supply cable screwed on a centre terminal in the board and the small bias cable.
- 7) Unscrew the input and output RF connections, at the module opposite sides.
- 8) Carefully unscrew the RF transistor flanges from the heatsink base-plate. This operation, if not properly done, may mechanically over-stress the transistor, cracking the internal delicate beryllium-oxide ceramic which supports the active silicon dies and determine unrecoverable

damage of the device.

CAUTION: beryllium-oxide is toxic and must not be thrown with domestic refuse but in specialised toxic material disposals. No special handling precaution must be paid when the transistors or power resistors are not mechanically broken, apart those deriving from the handling of mechanically fragile (and very costly) devices. If the transistor or resistor flange is broken, avoid to get in touch with it and the brittle white exposed internal ceramic or inhaling dust of it. Dispose the transistor or the entire broken module as previously described.

- 9) Make a note of the position and the length and remove the threaded screen spacers and the board fixing screws.
- 10) Remove the broken module and clean the supporting heatsink base-plate before mounting the new one.
- 11) Smear thin heat-conductive silicon grease below the flanges of the power transistors and resistors of the new module, before mounting it.
- 12) Position the new module, placing the threaded spacers and screws over the p.c. board avoiding to tighten them. When all the screws are placed, control the correct alignment of the transistors and resistors fixing holes and tighten the screws and spacers.
- 13) Insert the proper screws and washers, if any, across the transistors and resistors and carefully tighten them in several, alternate steps.
- 14) Reconnect the power supply and bias cables to the module.
- 15) Turn-on the whole amplifier fully connected to the supporting power and control rack without RF power, with RF load connected and driver exciter off. Enable the equipment, with the exciter still off.
- 16) Measure the bias current of the two transistors on the module, as explained on previous paragraphs 4 and 5. They were factory adjusted to 100 mA (1mV).
- 17) If the currents are off the range $50 \div 200$ mA ($0.5 \div 2$ mV), carefully retouch the bias trimmers on the board. A small clockwise rotation increases the bias current.
- 18) Reduce the output set power to a low value, acting on the front panel power set trimmer and turn on the exciter power.
- 19) Slowly increase the power-set and measure the balance of the current drained by each module at half level and at full power. Verify the limits written in paragraph 5.

20) Turn off the equipment, reassemble the screening covers and the bottom panel of the Unit and reposition it in its working location with full connections.

21) Perform a limited period of test at full power, i.e. $500 \div 550$ W and then reduce power at maximum nominal working level, i.e. no more than 500 W.

NA 501 AMPLIFIER - FRONT & TOP INTERNAL VIEW

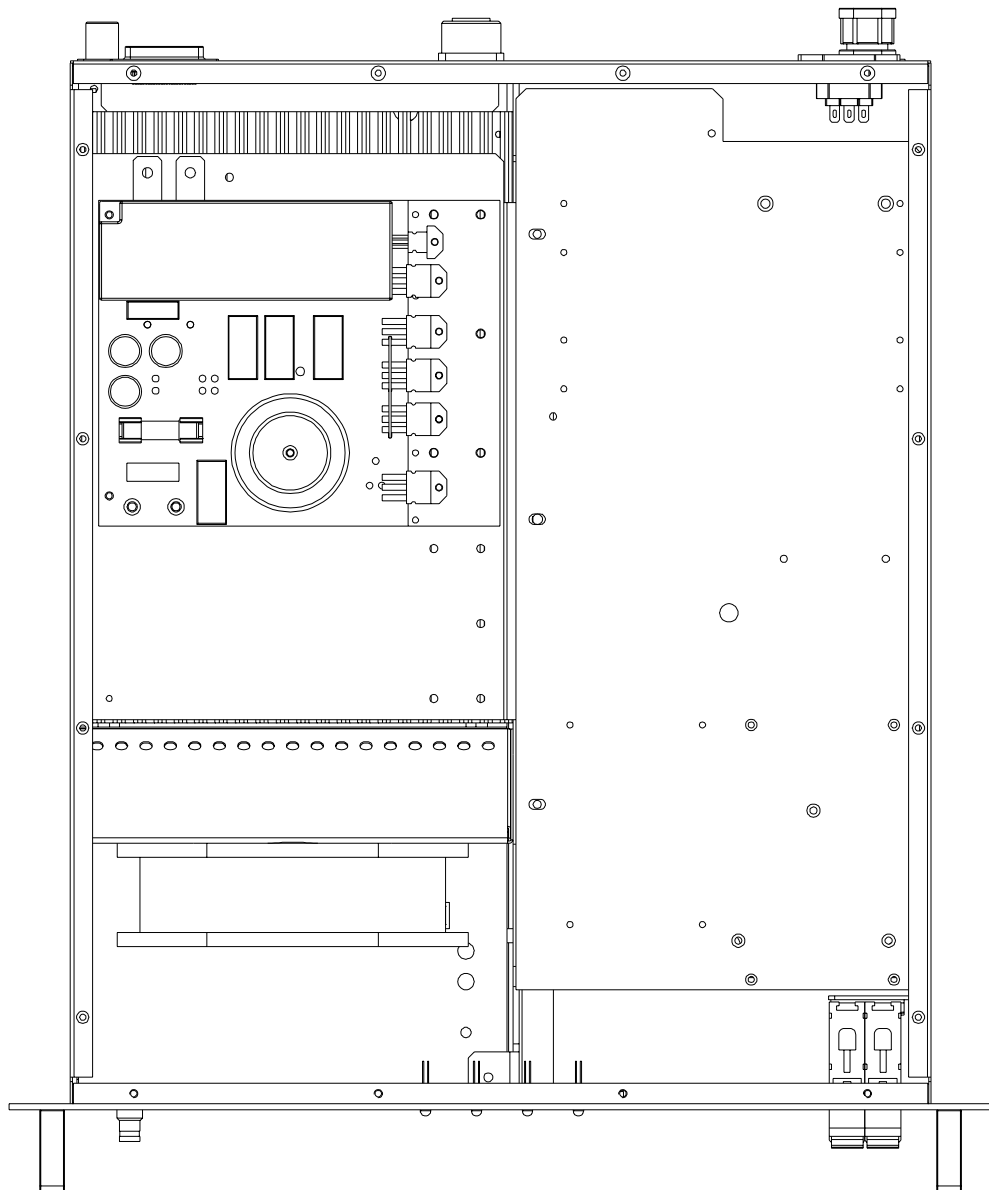
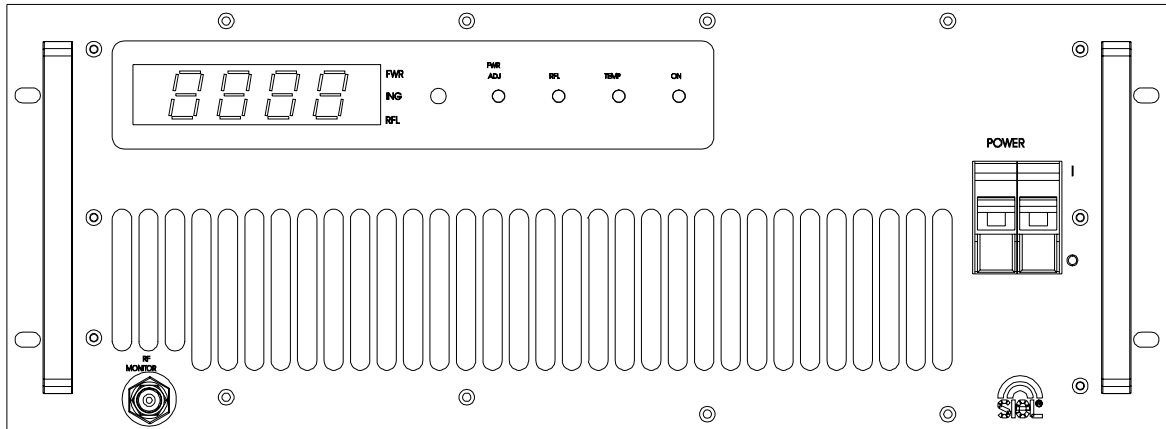

NA 501 AMPLIFIER - REAR & BOTTOM INTERNAL VIEW

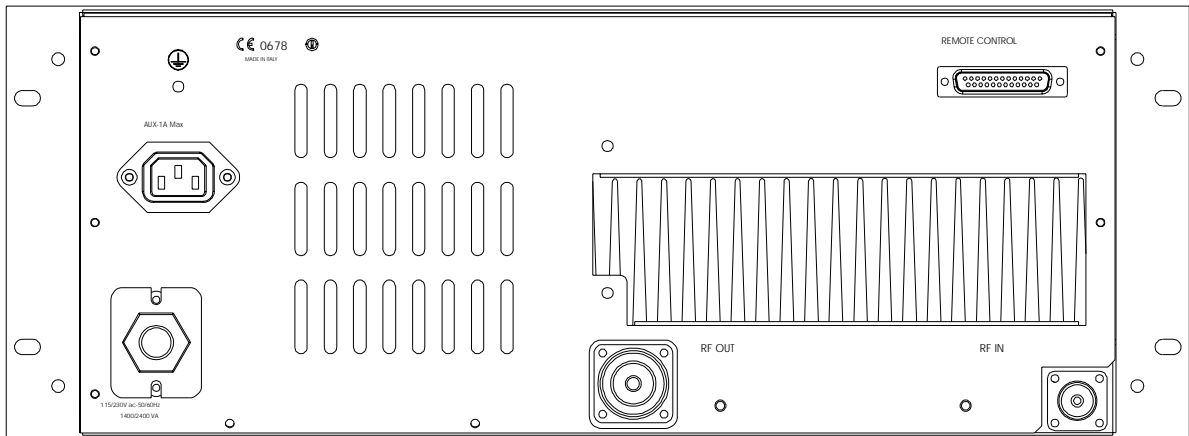
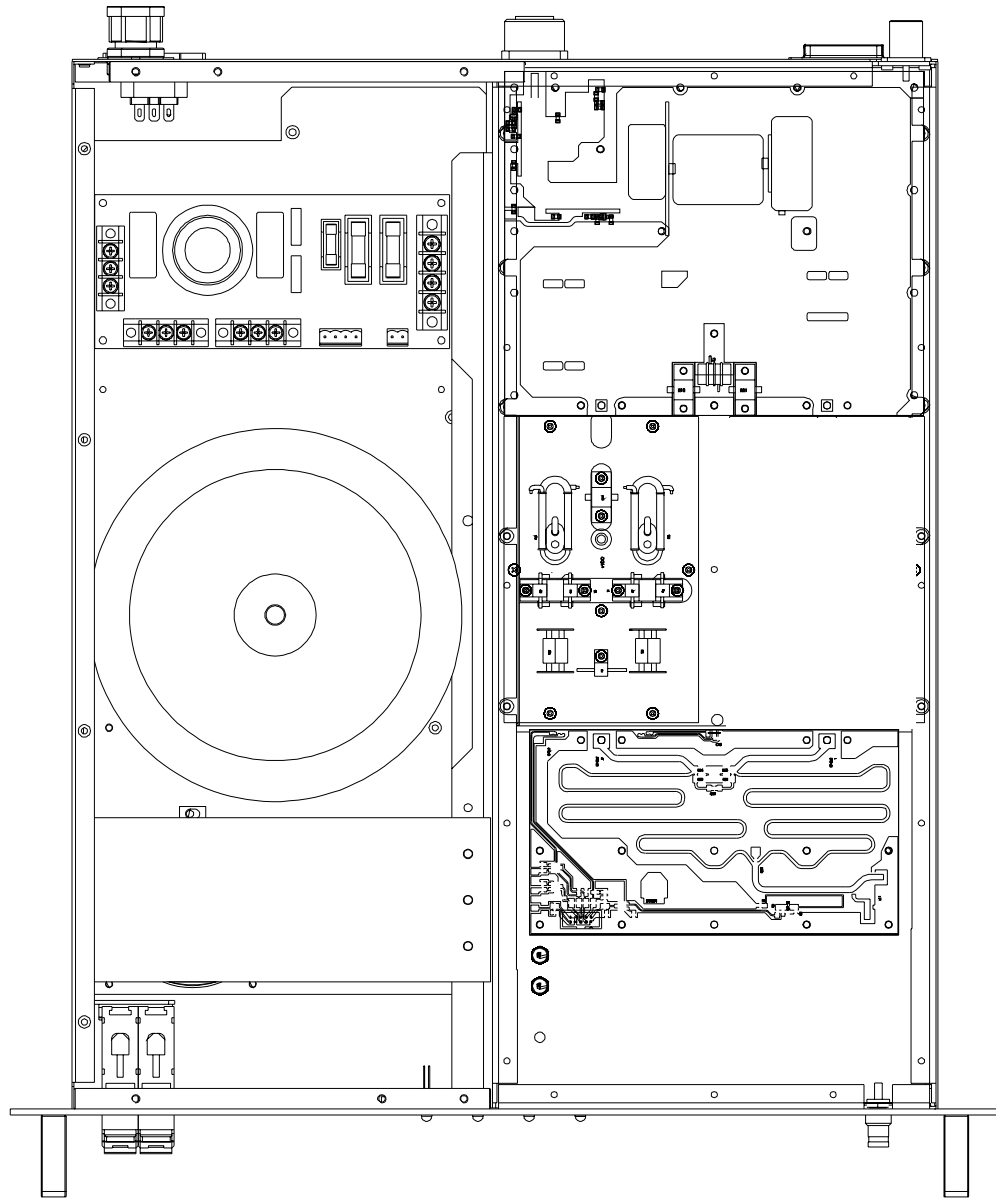

NA 501SM AMPLIFIER - ELECTRICAL DIAGRAM (220-240Vac) CONTROLS & MEASURES BOARD

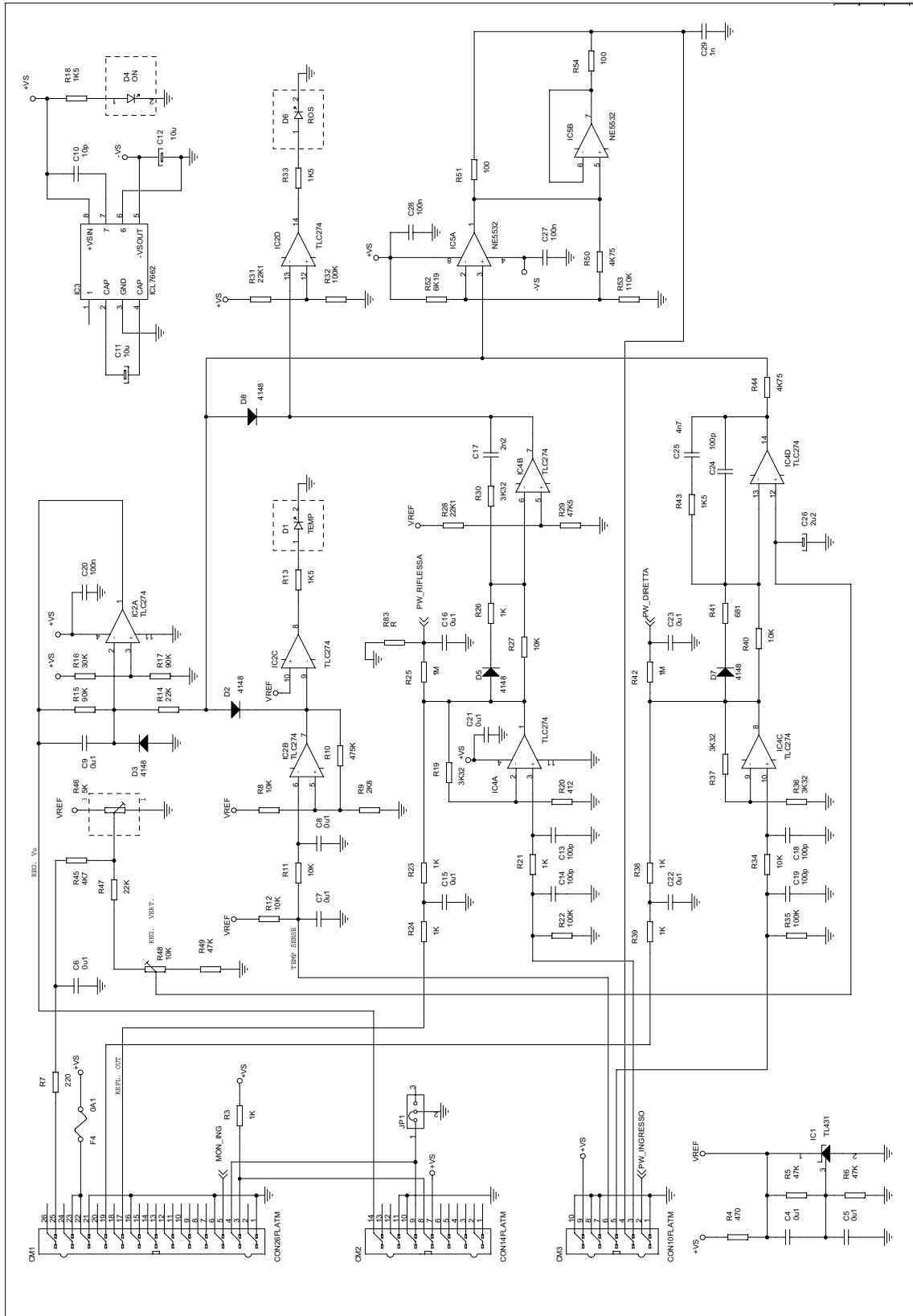

NA 501 - WIRING DIAGRAM

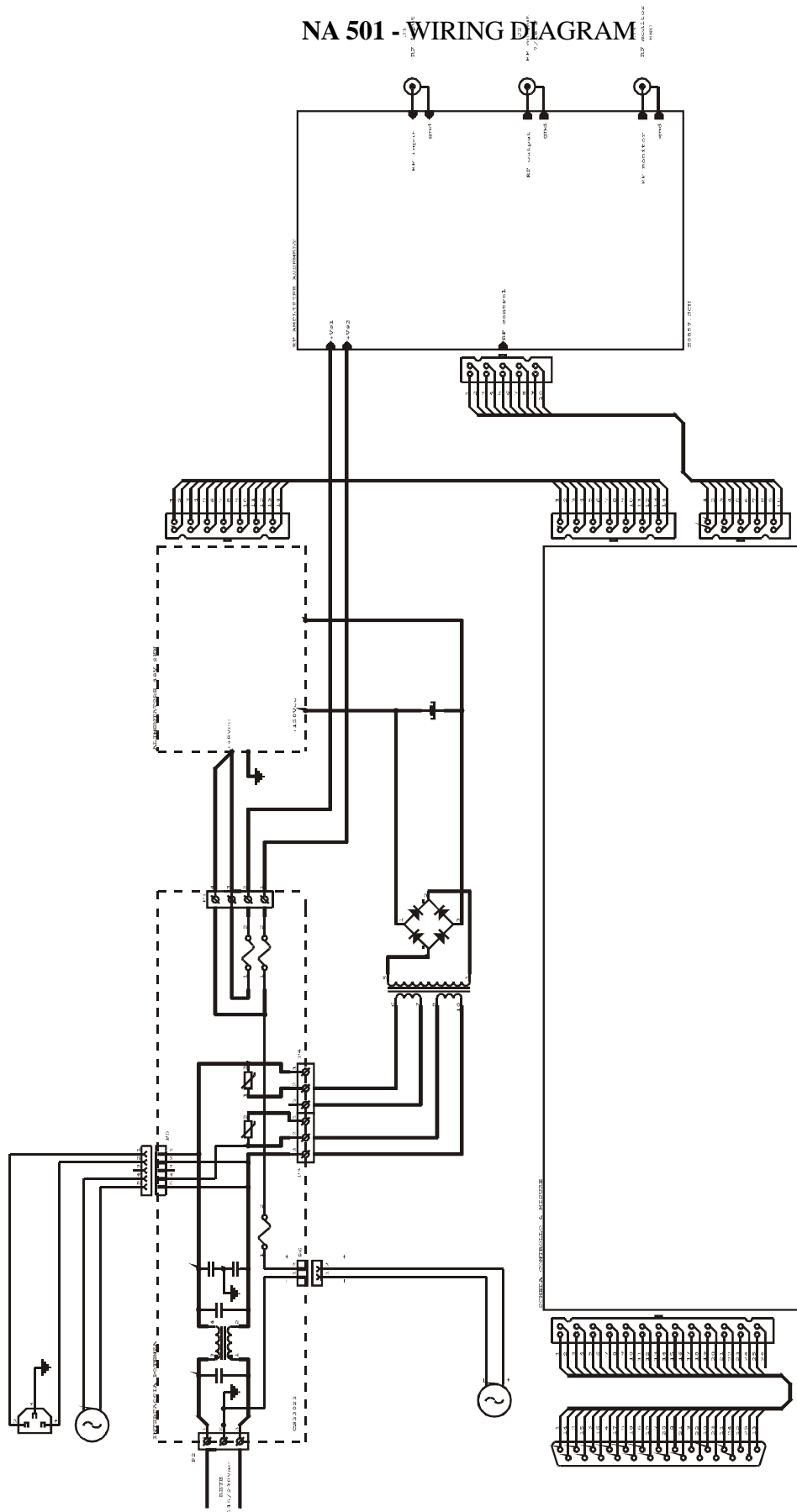

NA 501 AMPLIFIER - POWER SUPPLY FRONT-END

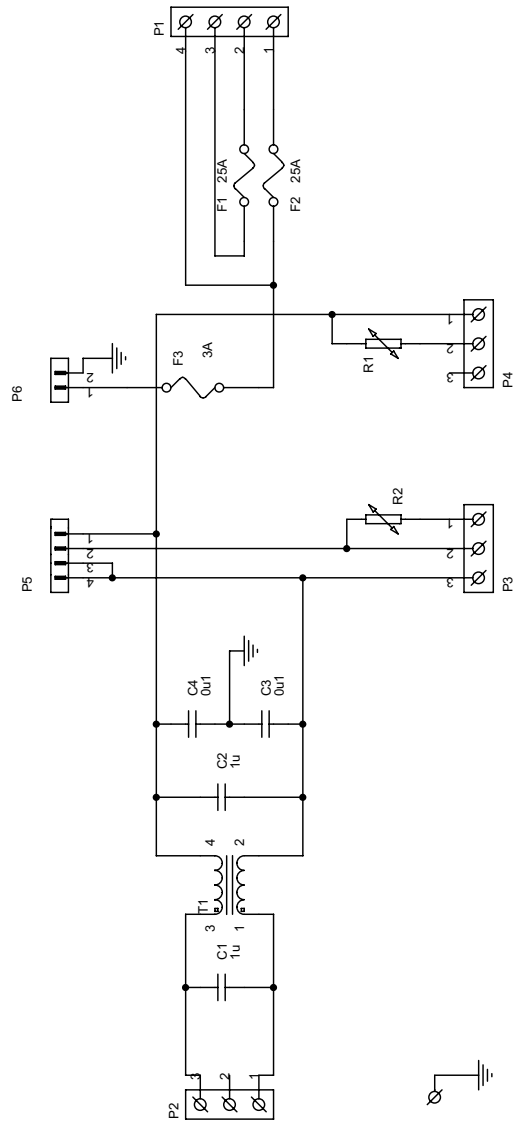

SRFB1K0AL2 - RF CONTROL DISPLAY- ELECTRICAL DIAGRAM

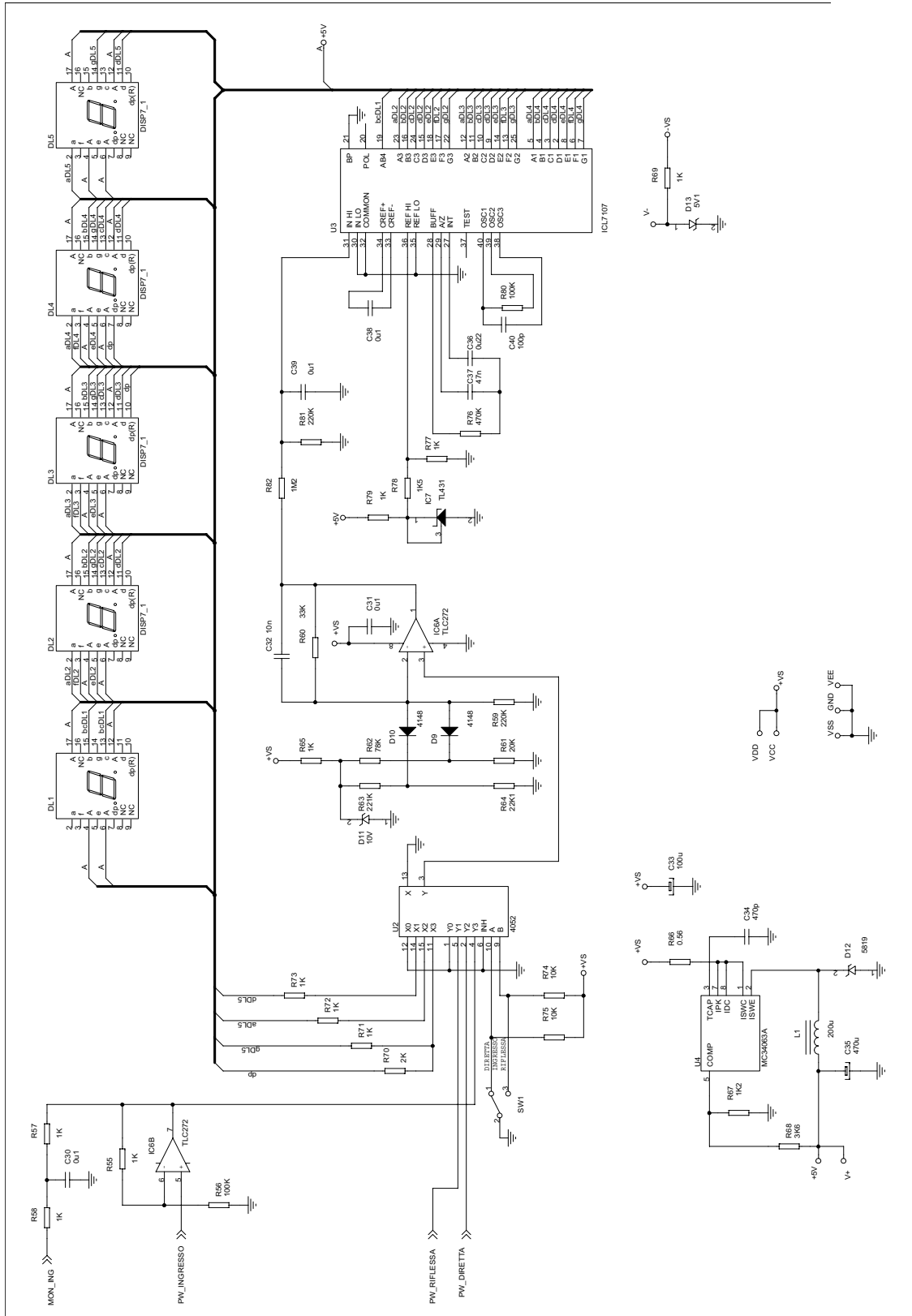

SRFB1K0AL2 - RF CONTROLS & MEASURES BOARD COMPONENT LAYOUT

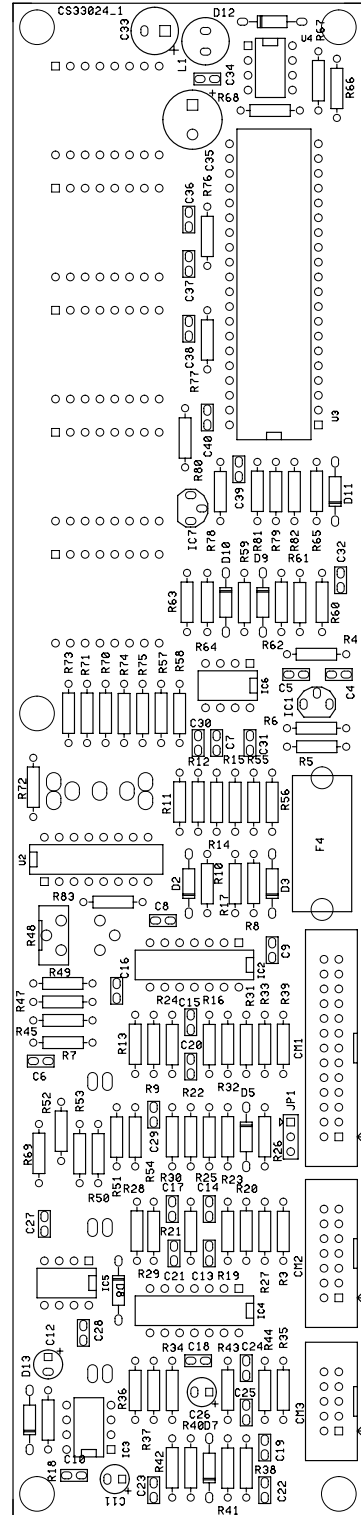
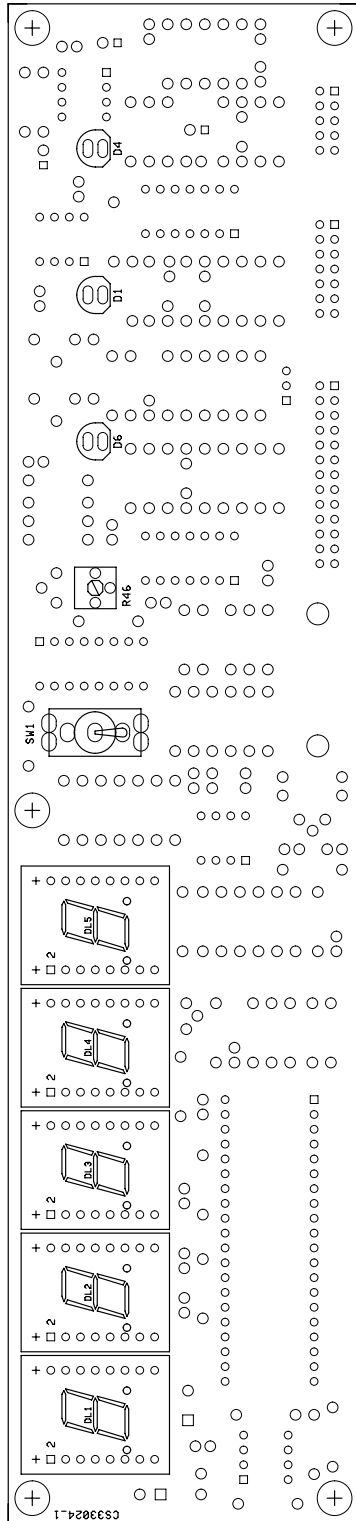

**SRFB1K5ALM - 48V/40A SMPS REGULATOR
ELECTRICAL DIAGRAM - POWER SECTION**

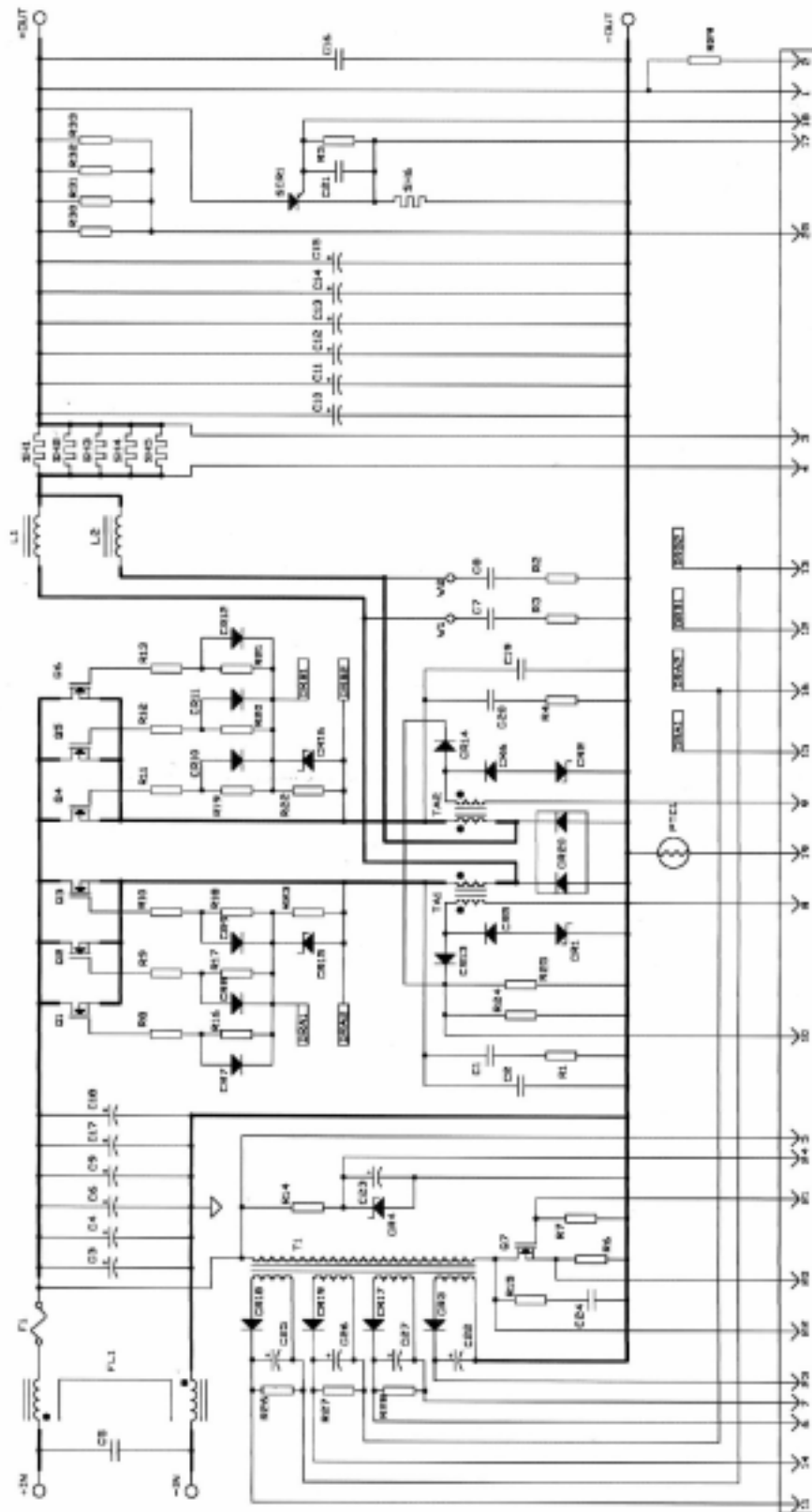

**SRFB1K5ALM - 48V/40A SMPS REGULATOR
ELECTRICAL DIAGRAM - CONTROL SECTION**

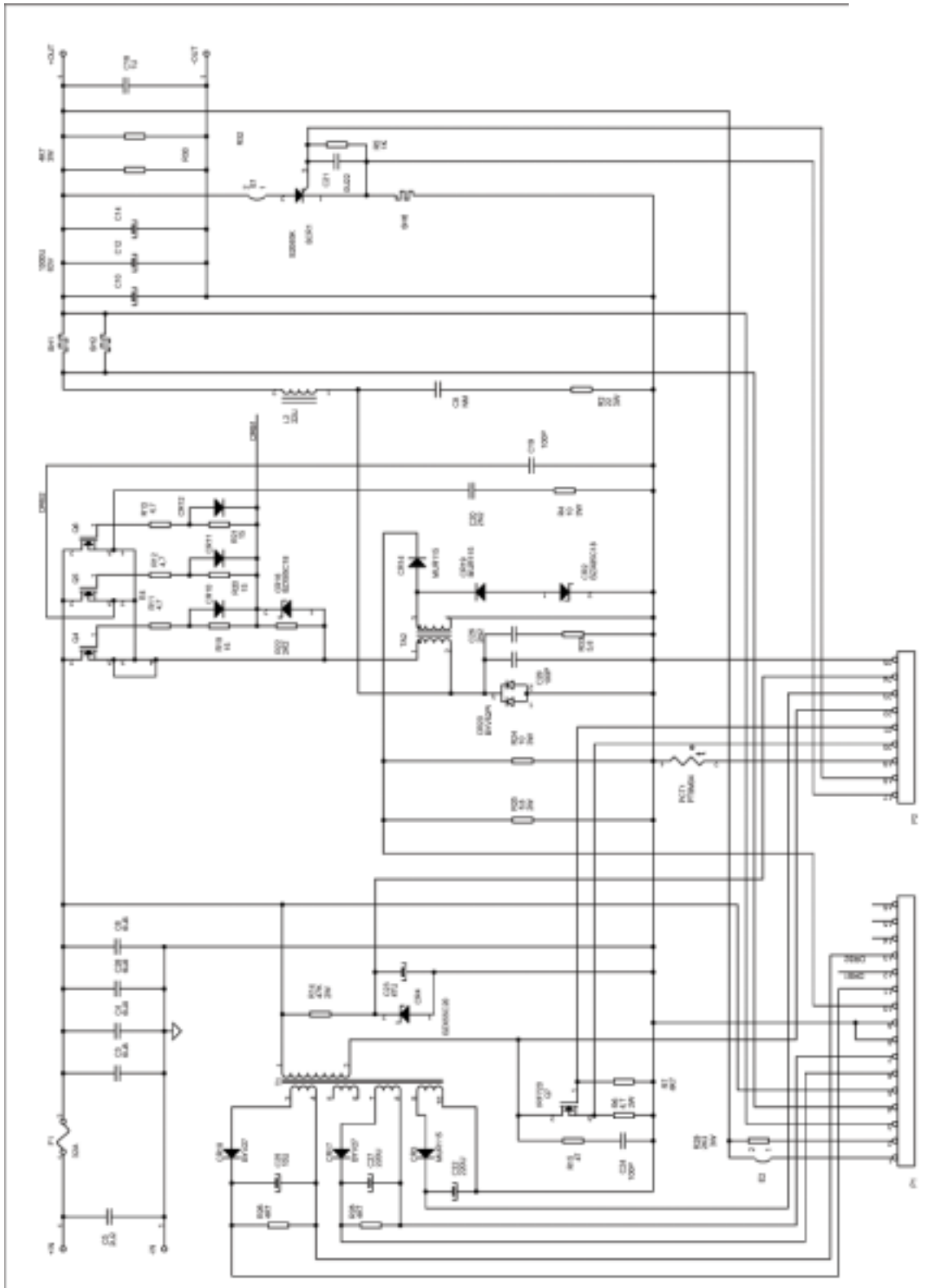

**SRFB1K5ALM - 48V/40A SMPS REGULATOR
COMPONENT LAYOUT - POWER SECTION**

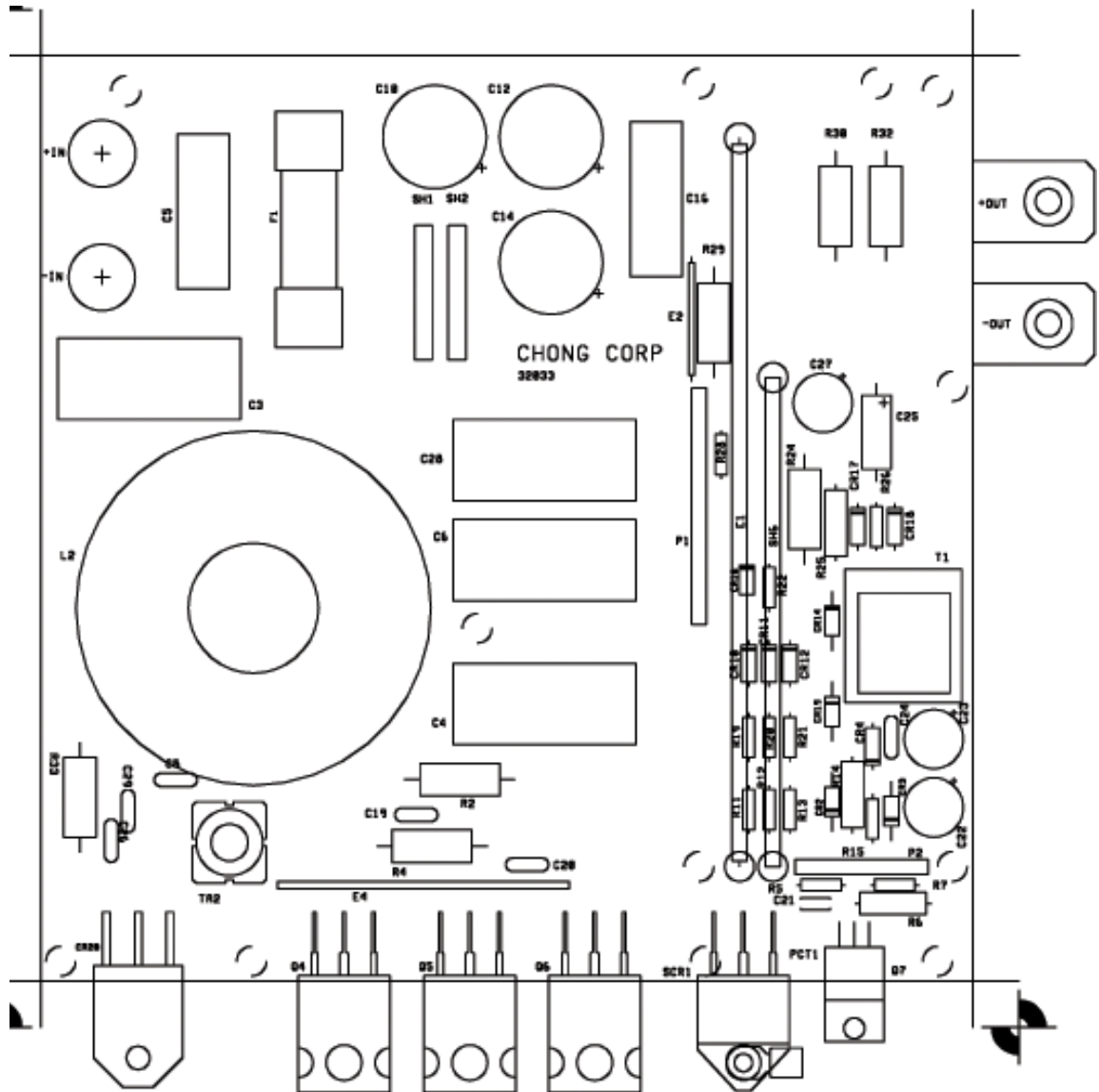

**SRFB1K5ALM - 48V/40A SMPS REGULATOR
COMPONENT LAYOUT - CONTROL SECTION**

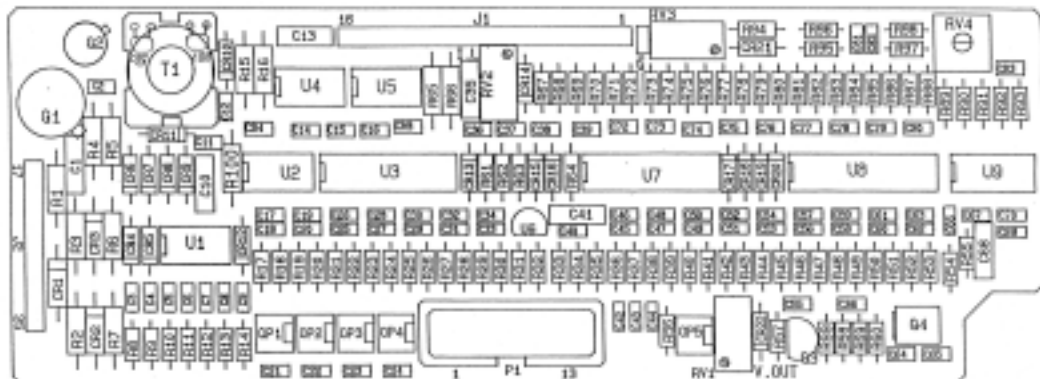

NA 501SM RF AMPLIFIER ASSEMBLY - ELECTRICAL DIAGRAM

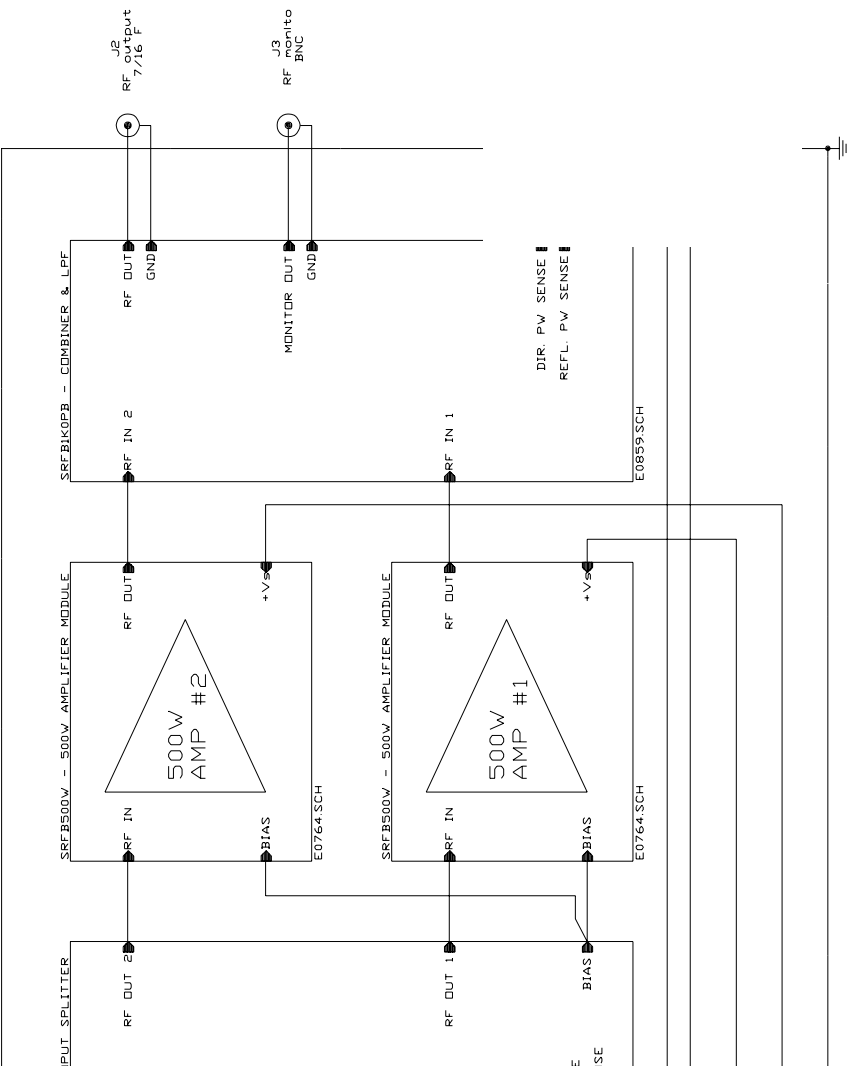

SRFB1K0IN - 2-PORT RF INPUT SPLITTER ELECTRICAL DIAGRAM

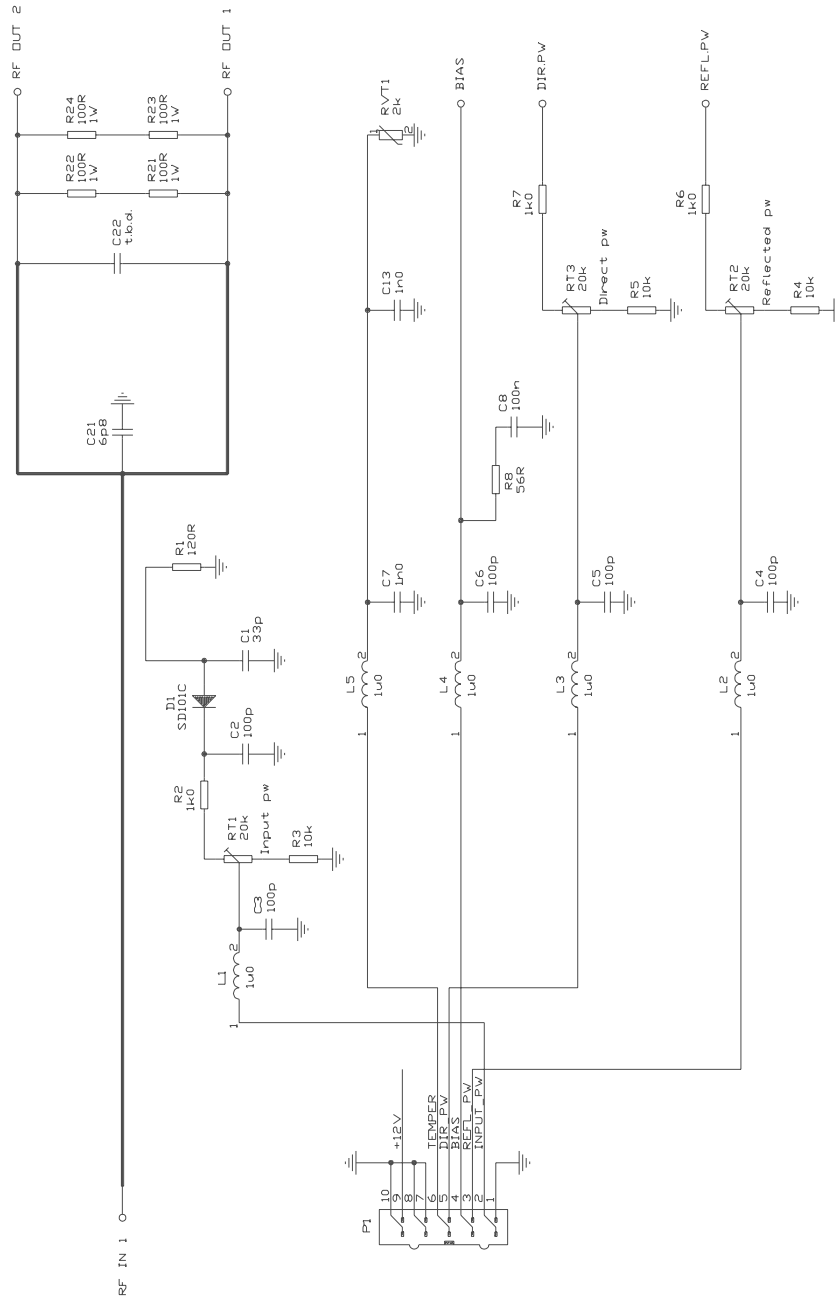

SRFB1K0PB - 2-PORT RF OUTPUT COMBINER & LPF ELECTRICAL DIAGRAM

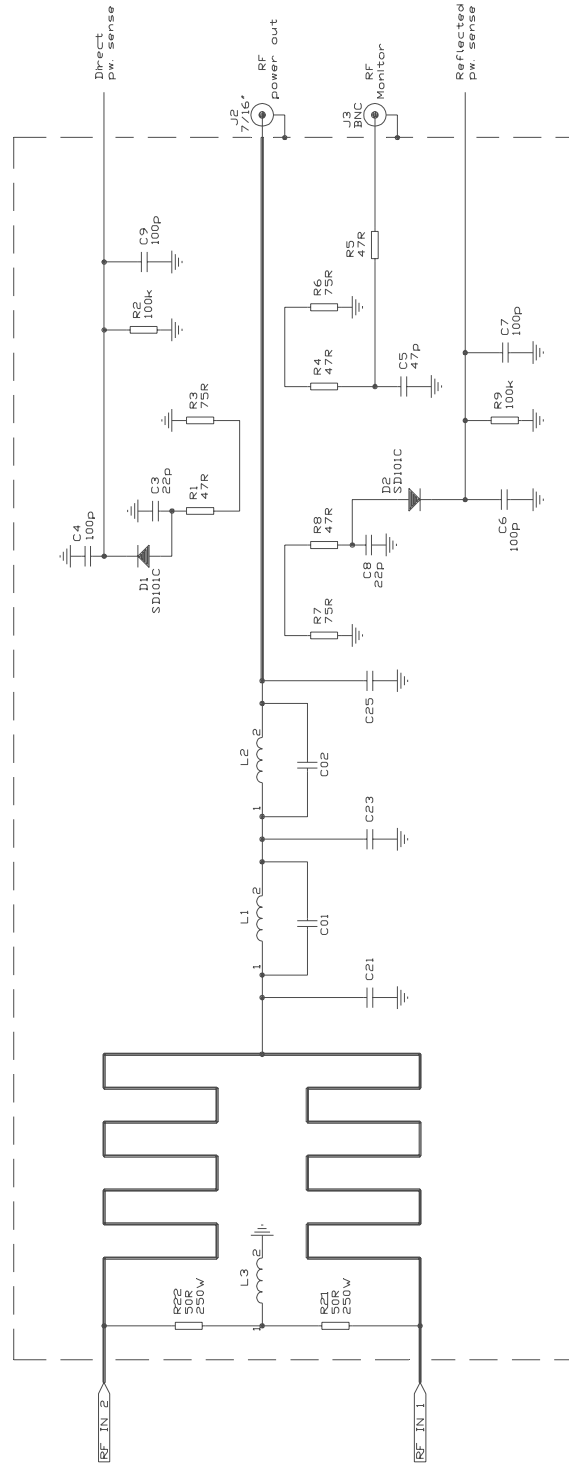

SRFB500W - 500W AMPLIFIER MODULE ELECTRICAL DIAGRAM

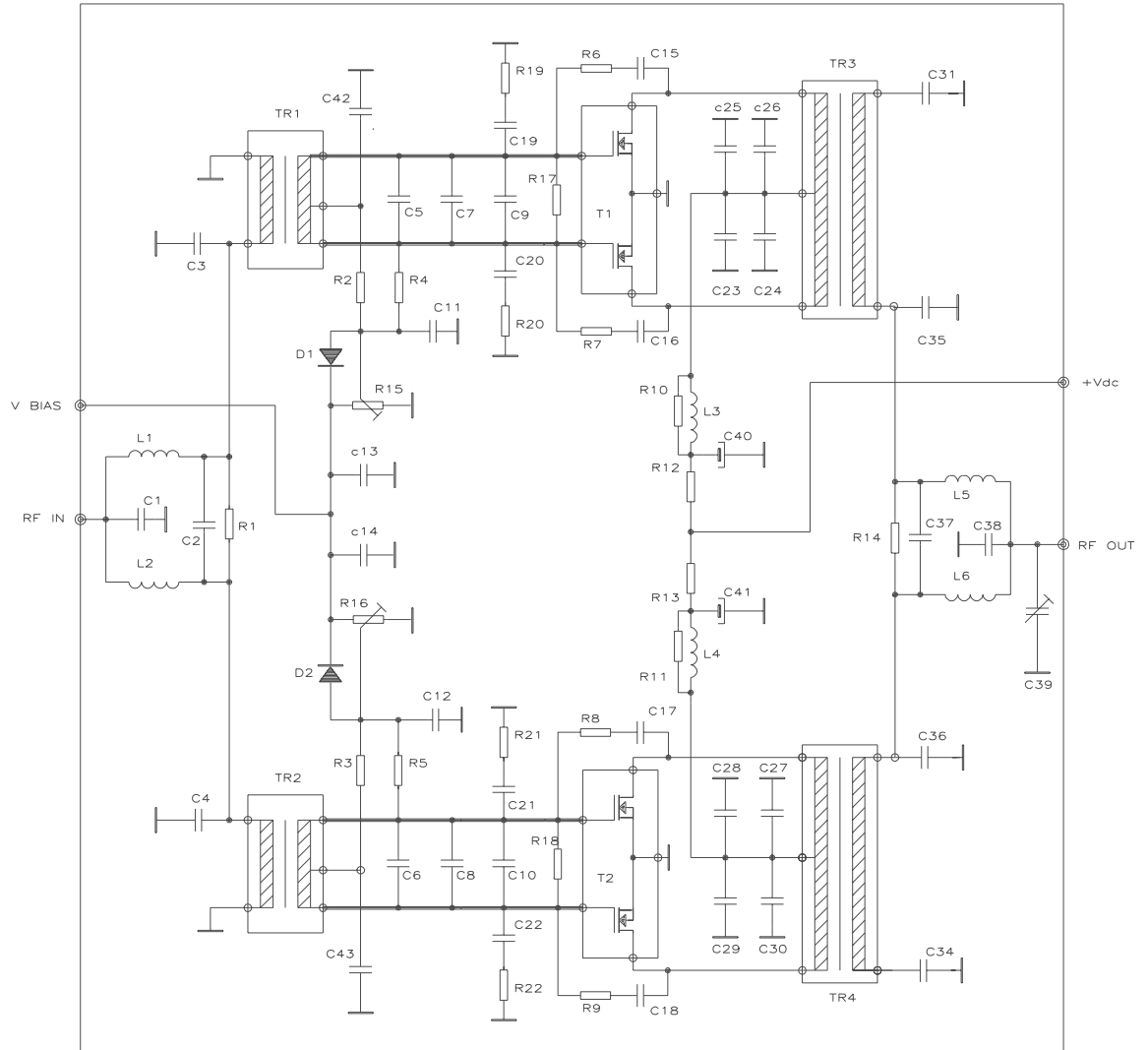

**SRFB500W - 500W AMPLIFIER MODULE
COMPONENT LAYOUT**

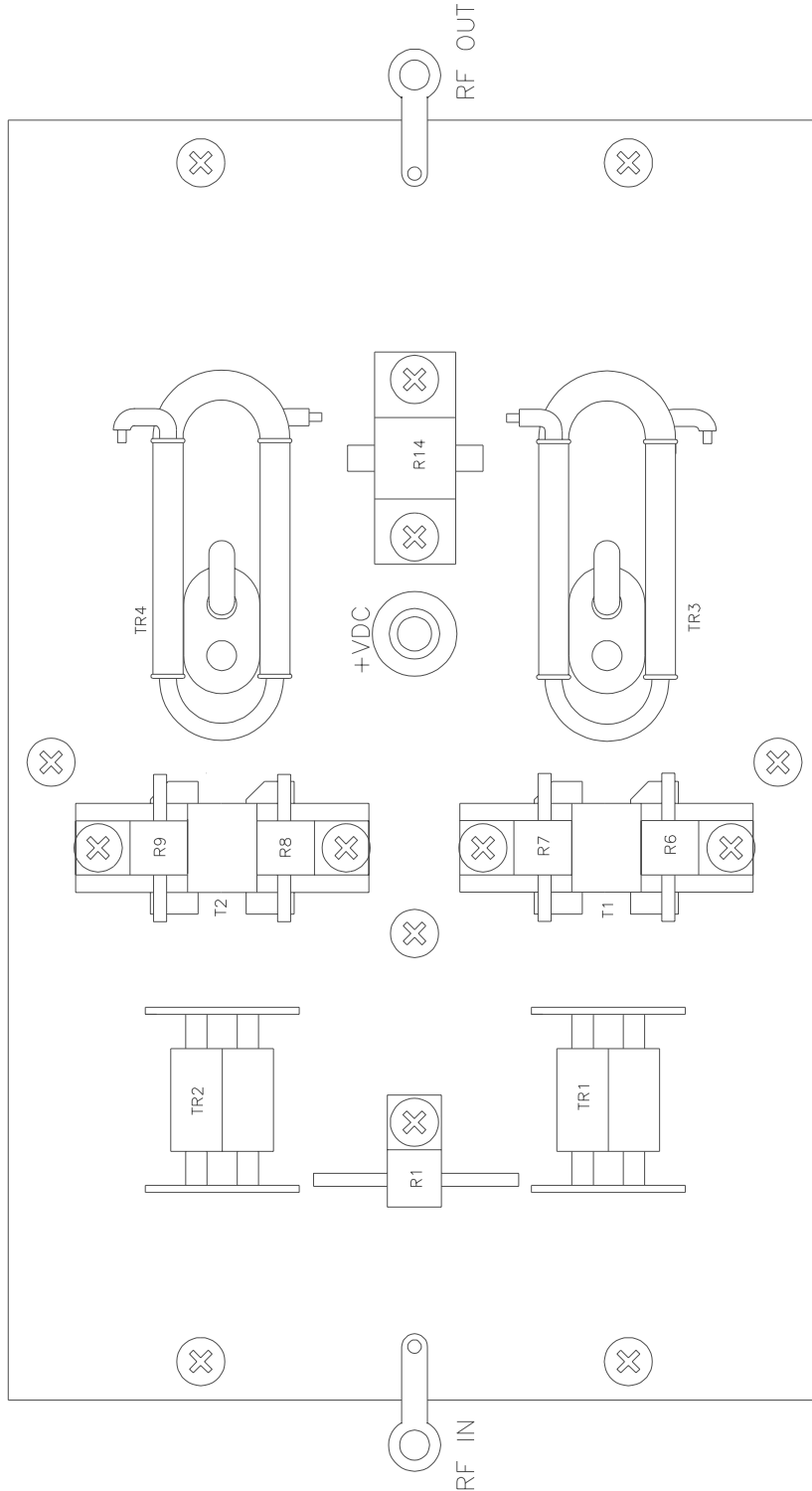

SRFB1K0AL2 – RF CONTROLS AND MEASURES BOARD

REF.	DESCRIPTION	Q.TY
C24	CAPACITOR CERAMIC 100pF 2% 100V NP0 P5	1
C25	CAPACITOR CERAMIC 100pF 2% 100V NP0 P5	1
C26	CAPACITOR CERAMIC 100pF 2% 100V NP0 P5	1
C27	CAPACITOR CERAMIC 100pF 2% 100V NP0 P5	1
C31	CAPACITOR CERAMIC 100pF 2% 100V NP0 P5	1
C15	CAPACITOR CERAMIC 1nF 5% 50V P2,5 TC	1
C16	CAPACITOR CERAMIC 1nF 5% 50V P2,5 TC	1
C17	CAPACITOR CERAMIC 1nF 5% 50V P2,5 TC	1
C18	CAPACITOR CERAMIC 1nF 5% 50V P2,5 TC	1
C19	CAPACITOR CERAMIC 1nF 5% 50V P2,5 TC	1
C20	CAPACITOR CERAMIC 1nF 5% 50V P2,5 TC	1
C21	CAPACITOR CERAMIC 1nF 5% 50V P2,5 TC	1
C22	CAPACITOR CERAMIC 1nF 5% 50V P2,5 TC	1
C23	CAPACITOR CERAMIC 1nF 5% 50V P2,5 TC	1
C28	CAPACITOR CERAMIC 1nF 5% 50V P2,5 TC	1
C41	CAPACITOR CERAMIC 1nF 5% 50V P2,5 TC	1
C39	CAPACITOR ELECTROLITC VERT.105°C 100µF 25V D8	1
C5	CAPACITOR ELECTROLITC VERT.105°C 220µF 35V D10	1
C40	CAPACITOR POLYESTER 1,0nF 10% 100V P5	1
C33	CAPACITOR POLYESTER 2,2nF 10% 100V P5	1
C30	CAPACITOR POLYESTER 4,7nF 10% 100V P5	1
C36	CAPACITOR POLYESTER 100nF 10% 63V P5	1
C37	CAPACITOR POLYESTER 100nF 10% 63V P5	1
C43	CAPACITOR POLYESTER 470nF 10% 63V P5	1
C29	CAPACITOR TANTALIUM 2,2 µF 25V P5	1
C38	CAPACITOR TANTALIUM 4,7µF 16V P5	1
C47	CAPACITOR TANTALIUM 4,7µF 16V P5	1
D17	DIODE RECTIFIER 1N4004 SI 1A 400V	1
D13,	DIODE SIGNAL 1N4148 SI DO 35	3
D14,	DIODE SIGNAL 1N4148 SI DO 35	1
D15	DIODE SIGNAL 1N4148 SI DO 35	1
D16	DIODE SD103A SI SCHOTTKY RECT. 40V 0,5A	1
D4	DIODE ZENER 1068 400mW 6,8V DO 35	1
D5	DIODE ZENER 1112 400mW 12V DO 35	1
IC5	INTEGRATED CIRC. NE5532 DIP8 2-LOW NOISE OP.AMP	1
IC3	INTEGRATED CIRC. TLC274 DIP14 4-LCMOS OP.AMP	1
IC4	INTEGRATED CIRC. TLC274 DIP14 4-LCMOS OP.AMP	1
P1 12 POLES	PIN STRIP 2,54 M 6x6 DIR.20o40 POLES	18
P2 5 POLES	PIN STRIP 2,54 M 6x6 DIR.20o40 POLES	18
R16	RESISTOR RS2F/100 10.0 OHM 1/2W 1%	1
R5	RESISTOR RS2F/475 47.5 OHM 1/2W 1%	1
R57	RESISTOR RS2F0100 100 OHM 1/2W 1%	1
R58	RESISTOR RS2F0100 100 OHM 1/2W 1%	1
R31	RESISTOR RS2F0412 412 OHM 1/2W 1%	1
R61	RESISTOR RS2F0619 619 OHM 1/2W 1%	1
R62	RESISTOR RS2F0619 619 OHM 1/2W 1%	1
R33	RESISTOR RS2F0681 681 OHM 1/2W 1%	1
R34	RESISTOR RS2F1100 1.00K OHM 1/2W 1%	1
R45	RESISTOR RS2F1150 1.50K OHM 1/2W 1%	1
R47	RESISTOR RS2F1150 1.50K OHM 1/2W 1%	1
R48	RESISTOR RS2F1150 1.50K OHM 1/2W 1%	1
R3	RESISTOR RS2F1182 1.82K OHM 1/2W 1%	1

R52	RESISTOR RS2F1280	2.80K OHM	1/2W	1%	1
R29	RESISTOR RS2F1332	3.32K OHM	1/2W	1%	1
R30	RESISTOR RS2F1332	3.32K OHM	1/2W	1%	1
R32	RESISTOR RS2F1332	3.32K OHM	1/2W	1%	1
R38	RESISTOR RS2F1332	3.32K OHM	1/2W	1%	1
R23	RESISTOR RS2F1475	4.75K OHM	1/2W	1%	1
R24	RESISTOR RS2F1475	4.75K OHM	1/2W	1%	1
R46	RESISTOR RS2F1475	4.75K OHM	1/2W	1%	1
R56	RESISTOR RS2F1475	4.75K OHM	1/2W	1%	1
R54	RESISTOR RS2F1619	6.19K OHM	1/2W	1%	1
R25	RESISTOR RS2F2100	10.0K OHM	1/2W	1%	1
R26	RESISTOR RS2F2100	10.0K OHM	1/2W	1%	1
R37	RESISTOR RS2F2100	10.0K OHM	1/2W	1%	1
R43	RESISTOR RS2F2100	10.0K OHM	1/2W	1%	1
R49	RESISTOR RS2F2100	10.0K OHM	1/2W	1%	1
R50	RESISTOR RS2F2100	10.0K OHM	1/2W	1%	1
R51	RESISTOR RS2F2100	10.0K OHM	1/2W	1%	1
R59	RESISTOR RS2F2100	10.0K OHM	1/2W	1%	1
R60	RESISTOR RS2F2100	10.0K OHM	1/2W	1%	1
R22	RESISTOR RS2F2110	11.0K OHM	1/2W	1%	1
R2	RESISTOR RS2F2140	14.0K OHM	1/2W	1%	1
R35	RESISTOR RS2F2221	22.1K OHM	1/2W	1%	1
R39	RESISTOR RS2F2221	22.1K OHM	1/2W	1%	1
R28	RESISTOR RS2F2332	33.2K OHM	1/2W	1%	1
R36	RESISTOR RS2F2475	47.5K OHM	1/2W	1%	1
R40	RESISTOR RS2F3100	100K OHM	1/2W	1%	1
R55	RESISTOR RS2F3110	110K OHM	1/2W	1%	1
R27	RESISTOR RS2F3221	221K OHM	1/2W	1%	1
R53	RESISTOR RS2F3475	475K OHM	1/2W	1%	1
RT1	TRIMMER HORIZ. CERAM. RES. Q10	110-1K OHM			1
RT3	TRIMMER HORIZ. CERAM. RES. Q10	210-10K OHM			1
RT4	TRIMMER HORIZ. CERAM. RES. Q10	210-10K OHM			1
RT5	TRIMMER HORIZ. CERAM. RES. Q10	310-100K OH			1
TR4	TRANSISTOR 2N1711 TO5	60V 1A NPN GEN.P			1
TR5	TRANSISTOR BC556B TO92	65V.1A PNP GEN.P			1
for TR4	TRANSISTOR SPACER TO5	4mm NYLON			1
for IC5	SOCKET DIL08 LOW PROFILE	- I=7,62			1
for IC3, IC4	SOCKET DIL14 LOW PROFILE	- I=7,62			1
for IC3, IC4	SOCKET DIL14 LOW PROFILE	- I=7,62			1

SRFB1K0IN – 2-PORT INPUT SPLITTER

REF.	DESCRIPTION	Q.TY
	RFB1001 INPUT SPLITTER BOARD	
C21	CAPACITOR CHIP CERAM. 1206 6,8pF 5% 100V NP0	1
C1	CAPACITOR CHIP CERAM. 1206 33pF 5% 100V NP0	1
C2	CAPACITOR CHIP CERAM. 1206 100pF 5% 100V NP0	1
C3	CAPACITOR CHIP CERAM. 1206 100pF 5% 100V NP0	1
C4	CAPACITOR CHIP CERAM. 1206 100pF 5% 100V NP0	1
C5	CAPACITOR CHIP CERAM. 1206 100pF 5% 100V NP0	1
C6	CAPACITOR CHIP CERAM. 1206 100pF 5% 100V NP0	1
C7	CAPACITOR CHIP CERAM. 1206 1,0nF 10% 100V NP0	1
C13	CAPACITOR CHIP CERAM. 1206 1,0nF 10% 100V NP0	1
C8	CAPACITOR CHIP CERAM. 1206 100nF 10% 50V X7R	1
D1	DIODE BAT54S SOT23 DUAL SCHOTTKY .2A/30	1
L1	INDUCTOR CHIP 1210 1.0UH LO-Q	1
L2	INDUCTOR CHIP 1210 1.0UH LO-Q	1
L3	INDUCTOR CHIP 1210 1.0UH LO-Q	1
L4	INDUCTOR CHIP 1210 1.0UH LO-Q	1
L5	INDUCTOR CHIP 1210 1.0UH LO-Q	1
P1	MALE CONNECTOR C.S. FLAT CABLE 10p	1
R8	RESISTOR CHIP 1206 56 OHM 1/4W 1%	1
R1	RESISTOR CHIP 1206 120 OHM 1/4W 1%	1
R2	RESISTOR CHIP 1206 1.0K OHM 1/4W 1%	1
R6	RESISTOR CHIP 1206 1.0K OHM 1/4W 1%	1
R7	RESISTOR CHIP 1206 1.0K OHM 1/4W 1%	1
R3	RESISTOR CHIP 1206 10K OHM 1/4W 1%	1
R4	RESISTOR CHIP 1206 10K OHM 1/4W 1%	1
R5	RESISTOR CHIP 1206 10K OHM 1/4W 1%	1
R21	RESISTOR CHIP 2512 100 OHM 1W 5%	1
R22	RESISTOR CHIP 2512 100 OHM 1W 5%	1
R23	RESISTOR CHIP 2512 100 OHM 1W 5%	1
R24	RESISTOR CHIP 2512 100 OHM 1W 5%	1
RT1	TRIMMER RES.CERMET SMD 5x5 20k OHM G4BT	1
RT2	TRIMMER RES.CERMET SMD 5x5 20k OHM G4BT	1
RT3	TRIMMER RES.CERMET SMD 5x5 20k OHM G4BT	1
RVT1	RESISTOR PTC TO92 2,kOHM 25°C 1% 64-52-54	1

SRFB1K5ALM – 48V/70A SMPS REGULATOR CONTROL SECTION

REF.	DESCRIPTION	Q.ty
C 1	CAPACITOR, CERAMIC M.S. 0,22MF 50V P.5.08 X7R	1
C 7	CAPACITOR, CERAMIC M.S. 470PF 50V P.2.54 NPO	1
C59	CAPACITOR, CERAMIC M.S. 470PF 50V P.2.54 NPO	1
C86	CAPACITOR, CERAMIC M.S. 470PF 50V P.2.54 NPO	1
C2	CAPACITOR, CERAMIC M.S. 10000PF 50V P.2.54 X7R-	1
C3	CAPACITOR, CERAMIC M.S. 10000PF 50V P.2.54 X7R-	1
C4	CAPACITOR, CERAMIC M.S. 10000PF 50V P.2.54 X7R-	1
C9	CAPACITOR, CERAMIC M.S. 10000PF 50V P.2.54 X7R-	1
C15	CAPACITOR, CERAMIC M.S. 10000PF 50V P.2.54 X7R-	1
C25	CAPACITOR, CERAMIC M.S. 10000PF 50V P.2.54 X7R-	1
C26	CAPACITOR, CERAMIC M.S. 10000PF 50V P.2.54 X7R-	1
C29	CAPACITOR, CERAMIC M.S. 10000PF 50V P.2.54 X7R-	1
C32	CAPACITOR, CERAMIC M.S. 10000PF 50V P.2.54 X7R-	1
C39	CAPACITOR, CERAMIC M.S. 10000PF 50V P.2.54 X7R-	1
C40	CAPACITOR, CERAMIC M.S. 10000PF 50V P.2.54 X7R-	1
C42	CAPACITOR, CERAMIC M.S. 10000PF 50V P.2.54 X7R-	1
C43	CAPACITOR, CERAMIC M.S. 10000PF 50V P.2.54 X7R-	1
C45	CAPACITOR, CERAMIC M.S. 10000PF 50V P.2.54 X7R-	1
C51	CAPACITOR, CERAMIC M.S. 10000PF 50V P.2.54 X7R-	1
C55	CAPACITOR, CERAMIC M.S. 10000PF 50V P.2.54 X7R-	1
C56	CAPACITOR, CERAMIC M.S. 10000PF 50V P.2.54 X7R-	1
C57	CAPACITOR, CERAMIC M.S. 10000PF 50V P.2.54 X7R-	1
C71	CAPACITOR, CERAMIC M.S. 10000PF 50V P.2.54 X7R-	1
C73	CAPACITOR, CERAMIC M.S. 10000PF 50V P.2.54 X7R-	1
C76	CAPACITOR, CERAMIC M.S. 10000PF 50V P.2.54 X7R-	1
C77	CAPACITOR, CERAMIC M.S. 10000PF 50V P.2.54 X7R-	1
C81	CAPACITOR, CERAMIC M.S. 10000PF 50V P.2.54 X7R-	1
C82	CAPACITOR, CERAMIC M.S. 10000PF 50V P.2.54 X7R-	1
C 5	CAPACITOR, CERAMIC M.S. 1000PF 50V P.2.54 NPO	1
C14	CAPACITOR, CERAMIC M.S. 1000PF 50V P.2.54 NPO	1
C20	CAPACITOR, CERAMIC M.S. 1000PF 50V P.2.54 NPO	1
C21	CAPACITOR, CERAMIC M.S. 1000PF 50V P.2.54 NPO	1
C22	CAPACITOR, CERAMIC M.S. 1000PF 50V P.2.54 NPO	1
C23	CAPACITOR, CERAMIC M.S. 1000PF 50V P.2.54 NPO	1
C24	CAPACITOR, CERAMIC M.S. 1000PF 50V P.2.54 NPO	1
C28	CAPACITOR, CERAMIC M.S. 1000PF 50V P.2.54 NPO	1
C31	CAPACITOR, CERAMIC M.S. 1000PF 50V P.2.54 NPO	1
C33	CAPACITOR, CERAMIC M.S. 1000PF 50V P.2.54 NPO	1
C34	CAPACITOR, CERAMIC M.S. 1000PF 50V P.2.54 NPO	1
C36	CAPACITOR, CERAMIC M.S. 1000PF 50V P.2.54 NPO	1
C44	CAPACITOR, CERAMIC M.S. 1000PF 50V P.2.54 NPO	1
C52	CAPACITOR, CERAMIC M.S. 1000PF 50V P.2.54 NPO	1
C58	CAPACITOR, CERAMIC M.S. 1000PF 50V P.2.54 NPO	1
C65	CAPACITOR, CERAMIC M.S. 1000PF 50V P.2.54 NPO	1
C67	CAPACITOR, CERAMIC M.S. 1000PF 50V P.2.54 NPO	1
C70	CAPACITOR, CERAMIC M.S. 1000PF 50V P.2.54 NPO	1
C80	CAPACITOR, CERAMIC M.S. 1000PF 50V P.2.54 NPO	1
C83	CAPACITOR, CERAMIC M.S. 1000PF 50V P.2.54 NPO	1
C6	CAPACITOR, CERAMIC M.S. 100PF 50V P.2.54 NPO	1

C16	CAPACITOR, CERAMIC M.S. 100PF 50V P.2.54 NPO	1
C17	CAPACITOR, CERAMIC M.S. 100PF 50V P.2.54 NPO	1
C27	CAPACITOR, CERAMIC M.S. 100PF 50V P.2.54 NPO	1
C30	CAPACITOR, CERAMIC M.S. 100PF 50V P.2.54 NPO	1
C37	CAPACITOR, CERAMIC M.S. 100PF 50V P.2.54 NPO	1
C46	CAPACITOR, CERAMIC M.S. 100PF 50V P.2.54 NPO	1
C48	CAPACITOR, CERAMIC M.S. 100PF 50V P.2.54 NPO	1
C49	CAPACITOR, CERAMIC M.S. 100PF 50V P.2.54 NPO	1
C50	CAPACITOR, CERAMIC M.S. 100PF 50V P.2.54 NPO	1
C60	CAPACITOR, CERAMIC M.S. 100PF 50V P.2.54 NPO	1
C61	CAPACITOR, CERAMIC M.S. 100PF 50V P.2.54 NPO	1
C62	CAPACITOR, CERAMIC M.S. 100PF 50V P.2.54 NPO	1
C69	CAPACITOR, CERAMIC M.S. 100PF 50V P.2.54 NPO	1
C72	CAPACITOR, CERAMIC M.S. 100PF 50V P.2.54 NPO	1
C74	CAPACITOR, CERAMIC M.S. 100PF 50V P.2.54 NPO	1
C78	CAPACITOR, CERAMIC M.S. 100PF 50V P.2.54 NPO	1
C8	CAPACITOR, CERAMIC M.S. 2200PF 50V P.2.54 NPO	1
C63	CAPACITOR, CERAMIC M.S. 2200PF 50V P.2.54 NPO	1
C79	CAPACITOR, CERAMIC M.S. 2200PF 50V P.2.54 NPO	3
C10	CAPACITOR, CERAMIC M.S. 1MF 50V P.5.08 Z5U	1
C13	CAPACITOR, CERAMIC M.S. 1MF 50V P.5.08 Z5U	1
C35	CAPACITOR, CERAMIC M.S. 1MF 50V P.5.08 Z5U	1
C41	CAPACITOR, CERAMIC M.S. 1MF 50V P.5.08 Z5U	1
C68	CAPACITOR, CERAMIC M.S. 1MF 50V P.5.08 Z5U	1
C38	CAPACITOR, CERAMIC M.S. 1MF 50V P.5.08 X7R	1
C47	CAPACITOR, CERAMIC M.S. 1MF 50V P.5.08 X7R	1
C53	CAPACITOR, CERAMIC M.S. 1MF 50V P.5.08 X7R	1
C54	CAPACITOR, CERAMIC M.S. 1MF 50V P.5.08 X7R	1
C66	CAPACITOR, CERAMIC M.S. 1MF 50V P.5.08 X7R	1
C75	CAPACITOR, CERAMIC M.S. 1MF 50V P.5.08 X7R	1
CR1	DIODE BZX55C16	1
CR2	DIODE BZX55C4V7	1
CR17	DIODE BZX55C4V7	1
CR3	DIODE BZX55C33	1
CR4	DIODE BAV21	1
CR13	DIODE BAV21	1
CR15	DIODE BAV21	1
CR16	DIODE BAV21	1
CR22	DIODE BAV21	1
CR5	DIODE BZX55C18	1
CR12	DIODE SCHOTTKY BAT43/BAT48	1
CR14	DIODE SCHOTTKY BAT43/BAT48	1
CR18	DIODE SCHOTTKY BAT43/BAT48	1
CR19	DIODE SCHOTTKY BAT43/BAT48	1
CR20	DIODE SCHOTTKY BAT43/BAT48	1
CR21	DIODE BZX55C15	1
OP1	I.C.SFH 610A-3	1
OP2	I.C.SFH 610A-3	1
OP3	I.C.SFH 610A-3	1
O4	I.C.SFH 610A-3	1
OP5	I.C.SFH 610A-3	1
CS1	PRINTED CIRCUIT	1
P1	CONNECTOR STRAIGHT 16P. 2,54 L.P.	1
P2	CONNECTOR STRAIGHT 9P. 2.54 L.P.	1
P3	CONNECTOR FLAT 2x7WAYS STRAIGHT 2,54 L.P.	1
Q1	BC 327	1
Q2	BC 337	1

Q3	BC 337	1
Q4	MOSFET IRDFD9120	1
R1	RESISTOR S.M. 220 1/2W P.10	1
R2	RESISTOR S.M. 220 1/2W P.10	1
R3	RESISTOR S.M. 220 1/2W P.10	1
R4	RESISTOR S.M. 330 1/2W P.10	1
R5	RESISTOR S.M. 330 1/2W P.10	1
R6	RESISTOR S.M. 1K 1/2W P.10	1
R 7	RESISTOR S.M. 1K 1/2W P.10	1
R8	RESISTOR S.M. 470 1/4W P.6.35	1
R12	RESISTOR S.M. 470 1/4W P.6.35	1
R34	RESISTOR S.M. 470 1/4W P.6.35	1
R9	RESISTOR S.M. 11K 1/4W P.6.35	1
R10	RESISTOR S.M. 220K 1/4W P.6.35	1
R90	RESISTOR S.M. 220K 1/4W P.6.35	1
R91	RESISTOR S.M. 220K 1/4W P.6.35	1
R11	RESISTOR S.M. 2K2 1/4W P.6.35	1
R23	RESISTOR S.M. 2K2 1/4W P.6.35	1
R25	RESISTOR S.M. 2K2 1/4W P.6.35	1
R26	RESISTOR S.M. 2K2 1/4W P.6.35	1
R27	RESISTOR S.M. 2K2 1/4W P.6.35	1
R32	RESISTOR S.M. 2K2 1/4W P.6.35	1
R52	RESISTOR S.M. 2K2 1/4W P.6.35	1
R55	RESISTOR S.M. 2K2 1/4W P.6.35	1
R62	RESISTOR S.M. 2K2 1/4W P.6.35	1
R64	RESISTOR S.M. 2K2 1/4W P.6.35	1
R77	RESISTOR S.M. 2K2 1/4W P.6.35	1
R100	RESISTOR S.M. 2K2 1/4W P.6.35	1
R13	RESISTOR S.M. 27 1/4W P.6.35	1
R 14	RESISTOR S.M. 9K1 1/4W P.6.35	1
R15	RESISTOR S.M. 100 1W 1% P.10	1
R66	RESISTOR S.M. 100 1W 1% P.10	1
R17	RESISTOR S.M. 1K2 1/4W P.6.35	1
R18	RESISTOR S.M. 1K2 1/4W P.6.35	1
19	RESISTOR S.M. 1K2 1/4W P.6.35	1
R21	RESISTOR S.M. 1K2 1/4W P.6.35	1
R20	RESISTOR S.M. 3K3 1/4W P.6.35	1
R99	RESISTOR S.M. 3K3 1/4W P.6.35	1
R22	RESISTOR S.M. 2K7 1/4W P.6.35	1
R40	RESISTOR S.M. 2K7 1/4W P.6.35	1
R24	RESISTOR S.M.470K 1/4W P.6.35	1
R48	RESISTOR S.M.470K 1/4W P.6.35	1
R81	RESISTOR S.M.470K 1/4W P.6.35	1
R28	RESISTOR S.M. 2M2 1/4W P.6.35	1
R29	RESISTOR S.M. 1K 1/4W P.6.35	1
R49	RESISTOR S.M. 1K 1/4W P.6.35	1
R56	RESISTOR S.M. 1K 1/4W P.6.35	1
R57	RESISTOR S.M. 1K 1/4W P.6.35	1
R70	RESISTOR S.M. 1K 1/4W P.6.35	1
R71	RESISTOR S.M. 1K 1/4W P.6.35	1
R72	RESISTOR S.M. 1K 1/4W P.6.35	1
R 92	RESISTOR S.M. 1K 1/4W P.6.35	1
R 93	RESISTOR S.M. 1K 1/4W P.6.35	1
R 30	RESISTOR S.M. 5K1 1/4W P.6.35	1
R31	RESISTOR S.M. 1K6 1/4W P.6.35	1
R33	RESISTOR S.M. 75 1/4W P.6.35	5
R37	RESISTOR S.M. 43K 1/4W P.6.35	1

R38	RESISTOR S.M. 4K3 1/4W P.6.35	1
R44	RESISTOR S.M. 4K7 1/4W P.6.35	1
R59	RESISTOR S.M. 4K7 1/4W P.6.35	1
R44	RESISTOR S.M. 4K7 1/4W P.6.35	1
R75	RESISTOR S.M. 4K7 1/4W P.6.35	1
R76	RESISTOR S.M. 4K7 1/4W P.6.35	1
R84	RESISTOR S.M. 4K7 1/4W P.6.35	1
R85	RESISTOR S.M. 4K7 1/4W P.6.35	1
R36	RESISTOR S.M. 22K 1/4W P.6.35	1
R46	RESISTOR S.M. 22K 1/4W P.6.35	1
R53	RESISTOR S.M. 22K 1/4W P.6.35	1
R35	RESISTOR S.M. 220 1/4W P.6.35	1
R39	RESISTOR S.M. 22 1/4W P.6.35	1
R60	RESISTOR S.M. 22 1/4W P.6.35	1
R41	RESISTOR S.M. 10K 1/4W P.6.35	1
R54	RESISTOR S.M. 10K 1/4W P.6.35	1
R87	RESISTOR S.M. 10K 1/4W P.6.35	1
R42	RESISTOR S.M. 100K 1/4W P.6.35	1
R51	RESISTOR S.M. 100K 1/4W P.6.35	1
R68	RESISTOR S.M. 100K 1/4W P.6.35	1
R82	RESISTOR S.M. 100K 1/4W P.6.35	1
R83	RESISTOR S.M. 100K 1/4W P.6.35	1
R43	RESISTOR S.M. 7K5 1/4W P.6.35	1
R45	RESISTOR S.M. 27K 1/4W P.6.35	1
R61	RESISTOR S.M. 27K 1/4W P.6.35	1
R47	RESISTOR S.M. 1K5 1/4W P.6.35	1
R50	RESISTOR S.M. 510 1/4W P.6.35	1
R58	RESISTOR S.M. 8K2 1/4W P.6.35	1
R63	RESISTOR S.M. 270K 1/4W P.7.5	1
R67	RESISTOR S.M. 82K 1/4W P.6.35	1
R69	RESISTOR S.M. 91 1/4W P.6.35	1
R73	RESISTOR S.M. 180 1/4W P.6.35	1
R74	RESISTOR S.M. 47K 1/4W P.6.35	1
R78	RESISTOR S.M. 2K 1/4W P.6.35	1
R79	RESISTOR S.M. 68K 1/4W P.6.35	1
R80	RESISTOR S.M. 1M 1/4W P.6.35	1
R86	RESISTOR S.M. 15K 1/4W P.6.35	1
R88	RESISTOR S.M. 6K2 1/4W P.6.35	1
R89	RESISTOR S.M. 330 1/4W P.6.35	1
R94	RESISTOR S.M. 150 1/4W P.6.35	1
R95	RESISTOR S.M. 3K3 1/4W 0,25% 25PPM P.6.35*	1
R96	RESISTOR S.M. 3K3 1/4W 0,25% 25PPM P.6.35*	1
R97	RESISTOR S.M. 15K 1/4W 0,25% 25PPM P.6.35*	1
R98	RESISTOR S.M. 15K 1/4W 0,25% 25PPM P.6.35*	1
-	SPACER FOR TO-5	1
-	SPACER FOR TO-18	1
RV1	TRIMMER 10K CERMET 10T 64Y	1
RV2	TRIMMER 50R CERMET 10T 64Y	1
RV3	TRIMMER 100R CERMET 10T 64Y	1
RV4	TRIMMER 20K CERMET 1T 3362P	1
U1	UC3844	1
U3	I.C. LP339N	1
U4	HCPL-3120	1
U5	HCPL-3120	1
U6	I.C. LM336BZ5.0	1
U7	I.C. LM2902N	1
U8	I.C. UC3846N	1

SRFB1K5ALM 48V/70A SMPS REGULATOR		
POWER SECTION		
REF.	DESCRIPTION	Q.ty
C1	CAPACITOR, CERAMIC 2,2NF 1KV P.5.08	1
C20	CAPACITOR, CERAMIC 2,2NF 1KV P.5.08	1
C2	CAPACITOR, CERAMIC 100PF 1KV P.5.08	1
C19	CAPACITOR, CERAMIC 100PF 1KV P.5.08	1
C24	CAPACITOR, CERAMIC 100PF 1KV P.5.08	1
C5	CAPACITOR, POLY. 2,2MF 250V P.22.5 MKT1822	1
C16	CAPACITOR, POLY. 1MF 250V P.22.5 MKT1822	1
C21	CAPACITOR, CER. M.S. 0,22MF 100V P.5,08 X7R1	1
C3	CAPACITOR, ELECTROLITIC VERT. 1000MF 200V P.10 35x35	1
C4	CAPACITOR, ELECTROLITIC VERT. 1000MF 200V P.10 35x35	1
C6	CAPACITOR, ELECTROLITIC VERT. 1000MF 200V P.10 35x35	1
C9	CAPACITOR, ELECTROLITIC VERT. 1000MF 200V P.10 35x35	1
C17	CAPACITOR, ELECTROLITIC VERT. 1000MF 200V P.10 35x35	1
C18	CAPACITOR, ELECTROLITIC VERT. 1000MF 200V P.10 35x35	1
C10	CAPACITOR, ELECTROLITIC VERT. 1000MF 63V P.7,5 18x30 SXE	1
C11	CAPACITOR, ELECTROLITIC VERT. 1000MF 63V P.7,5 18x30 SXE	1
C12	CAPACITOR, ELECTROLITIC VERT. 1000MF 63V P.7,5 18x30 SXE	1
C13	CAPACITOR, ELECTROLITIC VERT. 1000MF 63V P.7,5 18x30 SXE	1
C14	CAPACITOR, ELECTROLITIC VERT. 1000MF 63V P.7,5 18x30 SXE	1
C15	CAPACITOR, ELECTROLITIC VERT. 1000MF 63V P.7,5 18x30 SXE	1
C22	CAPACITOR, ELECTROLITIC VERT. 220MF 25V P.5,08	1
C27	CAPACITOR, ELECTROLITIC VERT. 220MF 25V P.5,08	1
C23	CAPACITOR, ELECTROLITIC VERT. 47MF 63V P.3,5 LXF	1
C25	CAPACITOR, ELECTROLITIC AX. 10MF 40/63V P.17,5	1
C26	CAPACITOR, ELECTROLITIC AX. 10MF 40/63V P.17,5	1
C7	OMITTED	1
C8	OMITTED	1
CR1	DIODE ZENER BZX85C18	1
CR2	DIODE ZENER BZX85C18	1
CR15	DIODE ZENER BZX85C18	1
CR16	DIODE ZENER BZX85C18	1
CR3	DIODE MUR115/BYV27-200	1
CR5	DIODE MUR115/BYV27-200	1
CR6	DIODE MUR115/BYV27-200	1
CR13	DIODE MUR115/BYV27-200	1
CR14	DIODE MUR115/BYV27-200	5
CR4	DIODE ZENER BZX55C20	1
CR7	DIODE BYV10-40/1N5819	1
CR8	DIODE BYV10-40/1N5819	1
CR9	DIODE BYV10-40/1N5819	1
CR10	DIODE BYV10-40/1N5819	1
CR11	DIODE BYV10-40/1N5819	1
CR12	DIODE BYV10-40/1N5819	6
CR17	DIODE BYV27-200	1
CR18	DIODE BYV27-200	1
CR19	DIODE BYV27-200	1
CR20	DIODE BYV255-V200	1
DT1	HEATSINK	1
E1	TEFZER WIRE D2,5mm	13cm
E2	SHEATHED WIRE JUMPER	1
E3	OUTPUT BAR	1
E4	OUTPUT BAR	1
E5	BUS BAR PART. C W.0089	1

E6	BUS BAR PART. D W.0089	1
E7	BUS BAR PART. E W.0089	1
E8	BUS BAR PART. F W.0089	1
E9	BUS BAR PART. G W.0089	2
E10	BUS BAR PART. H W.0089	1
F1	FUSE, SUPER FAST L350-80/80LET	1
FL1	FILTER INDUCTOR	1
L1	INDUCTOR 22uH D46	1
L2	INDUCTOR 22uH D46	1
CS1	PRINTED CIRCUIT	1
P1	STRAIGHT CONNECTOR 16P, 2.54 L.P.	1
P2	STRAIGHT CONNECTOR 9P, 2.54 L.P.	1
PTC1	PTH9M04-BD/471TS2F333	1
Q1	MOSFET IRFP250	1
Q2	MOSFET IRFP250	1
Q3	MOSFET IRFP250	1
Q4	MOSFET IRFP250	1
Q5	MOSFET IRFP250	1
Q6	MOSFET IRFP250	1
Q7	MOSFET IRF720	1
R1	RESISTOR MET. OXIDE 22 3W 5% p.20	1
R2	RESISTOR MET. OXIDE 22 3W 5% p.20	1
R4	RESISTOR MET. OXIDE 10 3W 5% p.20	1
R24	RESISTOR MET. OXIDE 10 3W 5% p.20	1
R5	RESISTOR S.M. 1K 1/2W	1
R6	RESISTOR MET. OXIDE 4,7 2W 5% p.15	1
R7	RESISTOR S.M. 4K7 1/2W	1
R26	RESISTOR S.M. 4K7 1/2W	1
R27	RESISTOR S.M. 4K7 1/2W	1
R28	RESISTOR S.M. 4K7 1/2W	1
R8	RESISTOR S.M. 4,7 1/2W	1
R9	RESISTOR S.M. 4,7 1/2W	1
R10	RESISTOR S.M. 4,7 1/2W	1
R11	RESISTOR S.M. 4,7 1/2W	1
R12	RESISTOR S.M. 4,7 1/2W	1
R13	RESISTOR S.M. 4,7 1/2W	1
R 14	RESISTOR MET. OXIDE 47K 2W 5% P.17,5	1
R 15	RESISTOR S.M. 47 1/2W	1
R16	RESISTOR S.M. 151/2W	1
R17	RESISTOR S.M. 151/2W	1
R18	RESISTOR S.M. 151/2W	1
R19	RESISTOR S.M. 151/2W	1
R20	RESISTOR S.M. 151/2W	1
R21	RESISTOR S.M. 151/2W	1
R22	RESISTOR S.M. 2K2 1/2W	1
R23	RESISTOR S.M. 2K2 1/2W	1
R 25	RESISTOR MET. OXIDE 6,8 2W 2% P.20	1
R 29	RESISTOR MET. OXIDE 2K2 3W 5% P.22.5	1
R30	RESISTOR MET. OXIDE 4K7 3W 5% P.22.5	1
R31	RESISTOR MET. OXIDE 4K7 3W 5% P.22.5	1
R32	RESISTOR MET. OXIDE 4K7 3W 5% P.22.5	1
,R33	RESISTOR MET. OXIDE 4K7 3W 5% P.22.5	1
R 3	OMITTED	1
SCR1	SCR S2065K	1
SH1	LOW OHM WIRE RESISTOR D3mm L=23	1
SH2	LOW OHM WIRE RESISTOR D3mm L=23	1
SH3	LOW OHM WIRE RESISTOR D3mm L=23	1

SH4	LOW OHM WIRE RESISTOR D3mm L=23	1
SH 5	LOW OHM WIRE RESISTOR D3mm L=23	1
SH6	LOW OHM WIRE RESISTOR D3mm L=88mm	1
T1	TRANSFORMER	1
TA1	TRANSFORMER	1
TA2	TRANSFORMER	1

SRFB1K0PB2 – 2 PORT RF OUTPUT COMBINER & LPF

REF.	DESCRIPTION	Q.TY
C2	AUXILIARY PRINTED CIRCUIT	1
C1	AUXILIARY PRINTED CIRCUIT	1
C3	CAPACITOR CHIP CERAM. 1206 33pF 5% 100V NP0	1
C8	CAPACITOR CHIP CERAM. 1206 33pF 5% 100V NP0	1
C5	CAPACITOR CHIP CERAM. 1206 47pF 5% 100V NP0	1
C4	CAPACITOR CHIP CERAM. 1206 220pF 5% 100V NP0	1
C6	CAPACITOR CHIP CERAM. 1206 220pF 5% 100V NP0	1
C7	CAPACITOR CHIP CERAM. 1206 220pF 5% 100V NP0	1
C9	CAPACITOR CHIP CERAM. 1206 220pF 5% 100V NP0	1
D1	DIODE BAT54S SOT23 DUAL SCHOTTKY .2A/30	1
D2	DIODE BAT54S SOT23 DUAL SCHOTTKY .2A/30	1
L1	RF LINE	1
L2	INDUCTOR TOROIDAL FERRITE F2 D16x8sp10	1
R5	RESISTOR CHIP 1206 18 OHM 1/4W 1%	1
R6	RESISTOR CHIP 1206 120 OHM 1/4W 1%	1
R3	RESISTOR CHIP 1206 150 OHM 1/4W 1%	1
R7	RESISTOR CHIP 1206 150 OHM 1/4W 1%	1
R14	RESISTOR CHIP 1206 270 OHM 1/4W 1%	1
R4	RESISTOR CHIP 1206 330 OHM 1/4W 1%	1
R12	RESISTOR CHIP 1206 1.0K OHM 1/4W 1%	1
R13	RESISTOR CHIP 1206 1.0K OHM 1/4W 1%	1
R10	RESISTOR FLANGED 250W 50 OHM	1
R11	RESISTOR FLANGED 250W 50 OHM	1

SRFB500W – 500W AMPLIFIER MODULE			
REF.	DESCRIPTION	Q.ty	MANUFACTURER
C1	CAPACITOR SMD 33pF 100V COG	1	
C2	CAPACITOR, SMD 10pF 100V COG	1	
C3	CAPACITOR, SMD 22pF 100V COG	1	
C4	CAPACITOR, SMD 22pF 100V COG	1	
C5	CAPACITOR, SMD 100pF 200V COG	1	
C6	CAPACITOR, SMD 100pF 200V COG	1	
C7	CAPACITOR, SMD 100pF 200V COG	1	
C8	CAPACITOR, SMD 100pF 200V COG	1	
C9	CAPACITOR, CER NP0 47pF 100V	1	
C10	CAPACITOR, CER NP0 47pF 100V	1	
C11	CAPACITOR, SMD 1nF 100V COG	1	
C12	CAPACITOR, SMD 1nF 100V COG	1	
C13	CAPACITOR, SMD 1nF 100V COG	1	
C14	CAPACITOR, SMD 1nF 100V COG	1	
C16	CAPACITOR, CERAMIC 470pF 100V	1	
C16	CAPACITOR, CERAMIC 470pF 100V	1	
C17	CAPACITOR, CERAMIC 470pF 100V	1	
C18	CAPACITOR, CERAMIC 470pF 100V	1	

C19	CAPACITOR, SMD 1nF 100V COG	1	
C20	CAPACITOR, SMD 1nF 100V COG	1	
C21	CAPACITOR, SMD 1nF 100V COG	1	
C22	CAPACITOR, SMD 1nF 100V COG	1	
C23	CAPACITOR, PORCELAIN 470pF 10% 200V C17	1	
C24	CAPACITOR, PORCELAIN 470pF 10% 200V C17	1	
C25	CAPACITOR, PORCELAIN 470pF 10% 200V C17	1	
C26	CAPACITOR, PORCELAIN 470pF 10% 200V C17	1	
C27	CAPACITOR, PORCELAIN 470pF 10% 200V C17	1	
C28	CAPACITOR, PORCELAIN 470pF 10% 200V C17	1	
C29	CAPACITOR, PORCELAIN 470pF 10% 200V C17	1	
C30	CAPACITOR, PORCELAIN 470pF 10% 200V C17	1	
C31	CAPACITOR, PORCELAIN 47pF 5% 500V C17	1	
C32	CAPACITOR, PORCELAIN 47pF 5% 500V C17	1	
C35	CAPACITOR, PORCELAIN 15pF 5% 500V C17	1	
C36	CAPACITOR, PORCELAIN 15pF 5% 500V C17	1	
C37	CAPACITOR, PORCELAIN 10pF 5% 500V C17	1	
C38	CAPACITOR, PORCELAIN 10pF 5% 500V C17	1	
C 39	CAPACITIVE TRIMMER 2-18pF	1	
C40	CAPACITOR, ELETTR. RD 100uF 63V	1	
C41	CAPACITOR, ELETTR. RD 100uF 63V	1	
C42	CAPACITOR, SMD 1nF 100V COG	1	
C43	CAPACITOR, SMD 1nF 100V COG	1	
D1	DIODE 1N4148	1	
D2	DIODE 1N4148	1	
L1	INDUCTOR 4 SPIRE d6 FILO d0,8	1	SIEL
L2	INDUCTOR 4 SPIRE d6 FILO d0,8	1	
L3	INDUCTOR 3 SPIRE SU R2W FILO d1	1	SIEL
L4	INDUCTOR 3 SPIRE SU R2W FILO d1	1	
L5	INDUCTOR 3,5 SPIRE d10,5 FILO d2	1	SIEL
L6	INDUCTOR 3,5 SPIRE d10,5 FILO d2	1	
R1	RESISTOR KDI 100 Ohm 20W	1	
R2	RESISTOR SMD 1206 22 Ohm 1/4 W	1	
R3	RESISTOR SMD 1206 22 Ohm 1/4 W	1	
R4	RESISTOR SMD 1206 22 Ohm 1/4 W	1	
R5	RESISTOR SMD 1206 22 Ohm 1/4 W	1	
R6	RESISTOR RF 200 Ohm 20W 5%	1	
R7	RESISTOR RF 200 Ohm 20W 5%	1	
R8	RESISTOR RF 200 Ohm 20W 5%	1	
R9	RESISTOR RF 200 Ohm 20W 5%	1	
R10	RESISTOR METAL OXIDE 10 Ohm 2W	1	
R11	RESISTOR METAL OXIDE 10 Ohm 2W	1	
R12	RESISTOR 0,01 Ohm 5W 5%	1	
R13	RESISTOR 0,01 Ohm 5W 5%	1	
R14	RESISTOR KDI 100 Ohm 250W	1	
R15	RESISTIVE TRIMMER 20T VERT 5 kOhm 3/8"	1	
R16	RESISTIVE TRIMMER 20T VERT 5 kOhm 3/8"	1	
R17	RESISTOR METAL OXIDE 1 Ohm 2W 5%	1	
R18	RESISTOR METAL OXIDE 1 Ohm 2W 5%	1	
R19	RESISTOR SMD 1206 51 Ohm 1/4W	1	
R20	RESISTOR SMD 1206 51 Ohm 1/4W	1	
R2	RESISTOR SMD 1206 51 Ohm 1/4W	1	
R22	RESISTOR SMD 1206 51 Ohm 1/4W	1	
T1	MOSFET BLF278 300W	1	
T2	MOSFET BLF278 300W	1	
TR1	VHF INPUT TRANSFORMER	1	SIEL
TR2	VHF INPUT TRANSFORMER	1	

TR3	VHF OUTPUT TRANSFORMER	1	SIEL
TR4	VHF OUTPUT TRANSFORMER	1	
Z 1	BRASS M4 TC STUD	1	
Z 1	400W RF AMPLIFIER PCB	1	