

# EXB500

87.5 ÷ 108 MHz FM 500W TRANSMITTER

## USER AND MAINTENANCE MANUAL

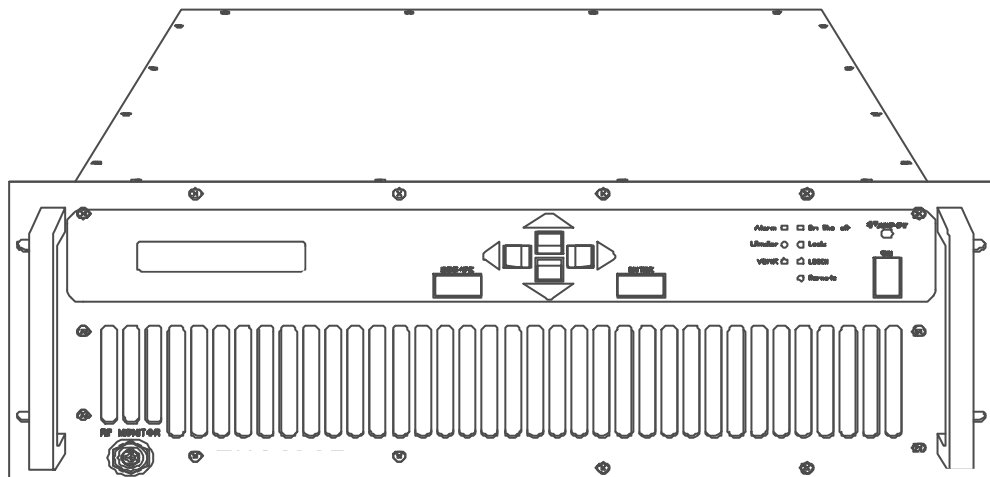

SOFRATEC BROADCAST EQUIPMENT

WWW.sofratec.com - e-mail : info@sofratec.com Tel: +33 4 93 01 99 99 Fax: +33 4 93 01 99 71

Rev. 1.0 - 03/02

## CONTENTS

<b>1</b>	<b>INTRODUCTION .....</b>	<b>3</b>
<b>2</b>	<b>GENERAL DESCRIPTION .....</b>	<b>4</b>
<b>3</b>	<b>TECHNICAL FEATURES .....</b>	<b>5</b>
<b>4</b>	<b>TECHNICAL SPECIFICATIONS .....</b>	<b>7</b>
<b>5</b>	<b>INSTALLATION AND USE .....</b>	<b>8</b>
5.1	FOREWORD TO INSTALLATION .....	8
5.2	PLACING THE APPARATUS .....	9
5.3	WIRING INTO THE MAINS .....	9
5.4	SYSTEM CONNECTION .....	11
5.5	LF CONNECTION AND PRESETS .....	12
5.6	OPERATION .....	17
<b>6</b>	<b>COMMANDS AND PROGRAMMING .....</b>	<b>20</b>
6.1	PASSWORD ORGANISATION .....	20
6.2	FACTORY DEFAULT PASSWORDS .....	21
6.3	MENU AND COMMANDS DESCRIPTION .....	21
<b>7</b>	<b>SERVICE AND MAINTENANCE .....</b>	<b>32</b>
<b>8</b>	<b>GUARANTEE .....</b>	<b>32</b>
<b>9</b>	<b>SERVICE MANUAL .....</b>	<b>33</b>
9.1	INTERNAL DESCRIPTION .....	33

### DRAWINGS

- A.1 EXB500, top & front assembly view  
EXB500, rear & bottom assembly view
- A.2 EXB500, general electric diagram (E0908)  
EXB500, exciter assembly electric diagram (E0909)  
SEXC25AL5, auxiliary power regulator board (E0805A)  
SEXC25CON, cpu controller and display board (E0838)  
SEXC1K05IN, input & interface board (E0911)  
SEXC25MB, lf and rf control mainboard (E0837)  
SEXC23COD2, stereo encoder board (E0868)  
SEXC25MOD, FM exciter board (E0839)  
ASEXC25AM5, 25W FM RF driver amplifier (E0691)  
EXB500SM, 500W RF amplifier assembly (E0857)  
SRFB1K5ALM, 48V/70A SMPS regulator module

## **EXB500**

### **87.5 ÷ 108 MHz FM 500W TRANSMITTER**

#### **INTRODUCTION**

The EXB500 series transmitters are the result of experience gained by SOFRATEC during years of producing FM broadcast equipment, transmitters, stl and stereo encoders.

These transmitters were specifically designed to comply with the latest international standards and the requirements of advanced broadcasters, meeting tighter specifications than usually required, at an affordable cost.

Great care went into producing a Hi-Fi-quality modulated signal, with low residual noise and distortion. The RF signal is also free from spurious and harmonic components to a higher degree than required by CCIR, European, USA and most other national standards.

To obtain this outstanding performance, SOFRATEC strongly recommend to rely on qualified personnel to install and verify the equipment which makes up the radio station, i.e. the transmitter, the possible stl and power amplifier, the corresponding antennas, cables and connectors. This will assure to achieve the best performance and stability in time.

To this aim, SOFRATEC especially recommend that their equipment should not be tampered with by unskilled personnel and its after-sale service is available to customers for any technical problem. Before proceeding to installation, please carefully read at least the general installation part of this manual, to gain confidence with the equipment.

The transmitters are very stable and changes to the internal pre-setting other than frequency and few other options are not usually required but, if they are, once again they must be done by skilled personnel, with proper instrumentation and service documentation. Improperly tampering with the settings may harm the apparatus or jeopardize the guaranteed performance.

**THIS EQUIPMENT COMPLIES WITH ALL RELEVANT  EMI/EMC AND SAFETY REQUIREMENTS, ETSI EN300384, ETS300447 AND EN60215 STANDARDS.**

**NO INTERNAL ADJUSTMENT OR PRESETTING IS REQUIRED DURING NORMAL OPERATIONS. THE APPARATUS SHALL BE PROPERLY EARTHED AND BE OPERATED WITH ALL THE COVERS CLOSED TO PREVENT ELECTRICAL HAZARDS AND COMPLY WITH EMC STANDARDS.**

**———— MAINS VOLTAGE MAY KILL ————**

SOFRATEC BROADCAST EQUIPMENT

WWW.sofratec.com - e-mail : info@sofratec.com Tel: +33 4 93 01 99 99 Fax: +33 4 93 01 99 71

## GENERAL DESCRIPTION

The EXB500 is a 500W rated, direct-synthesis, FM-modulated transmitter. Being digitally controlled, it is extensively on field programmable by front panel or remotely in every respect: frequency, power, channel sensitivity, preemphasis, functioning mode (mono, stereo, external mpx), clock and date and many other parameters without adjusting or substituting any part. A powerful 3-levels password management permits a very high degree of security and privacy as may be required in different situations. The apparatus requires little or no maintenance and its simple modular layout facilitates stage testing and servicing.

As imposed by various national standards, these transmitters incorporate sophisticated low-pass audio filters on mono and stereo channels, and a sharp acting modulation limiter, which is usually set at a peak deviation slightly higher than 75 kHz. Its intervention may nevertheless be avoided, if required, pre-setting its threshold at a deviation higher than 150 kHz.

Output frequency is phase-locked to a temperature-compensated crystal oscillator, which ensures superior precision and stability. A very low noise, low distortion VCO produces a harmonic-free, spurious-free signal. A lock control circuit inhibits the presence of power on the output until the apparatus is on the right frequency, when turning on.

To lower the noise threshold further, the low-frequency inputs are fitted with balanced input circuitry. The input level is precisely adjustable over a broad range, by means of a 0.5dB stepwise variable attenuators. The transmitter has an auxiliary input, specifically designed for RDS and SCA encoders. A modulation output permits to control other transmitters or STL's with the same internally processed high-quality mpx signal.

The alphanumeric display permits easy and accurate metering, adjustment and continuous monitoring of modulation levels, power, operation and internal parameters. All these information may be externally available on the same RS232 I/O port that may be used to remotely control the transmitter. In addition to the serial I/O, some signals (RF power, On the air state, Disable line) are available on a parallel I/O socket for easy interfacing with others analog controllers or supervisory systems.

A top-quality stereo encoder may be factory installed as option and even retrofitted in the field in a second time, requiring minimum technical skill. The powerful internal software and monitoring functions recognise its presence and enable its functions.

The RF power amplifier employs a broadband design and has plenty of reserve: the output power is feedback controlled for increased stability till higher than nominal level. High reflected power is limited to prevent output stage degradation; direct power is accordingly continuously reduced so as not to exceed the reflected power safety level. A sturdy telecom-grade high efficiency switch-mode power supply permits operation in a very wide and noisy mains environment.

The temperature alarm circuitry reduce the output power in case of high internal or ambient temperature, trying to continue to stay on the air in spite of the adverse conditions.

SOFRATEC BROADCAST EQUIPMENT

WWW.sofratec.com - e-mail : info@sofratec.com Tel: +33 4 93 01 99 99 Fax: +33 4 93 01 99 71

## TECHNICAL FEATURES

### FRONT PANEL COMMANDS AND SIGNALLING

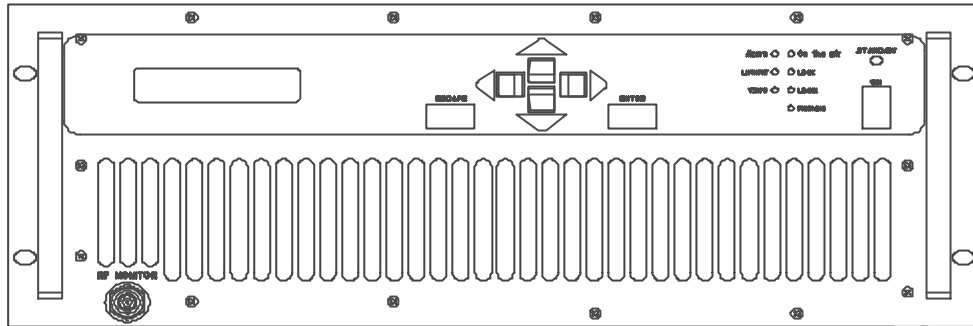

The EXB500 front panel is clean and easy to control. The wide alphanumeric display and the control keyboard permit a simple self-explanatory menu-driven navigation through the various options.

Great care was taken in the design of the software to allow natural feeling with the controls to permit operation and programming in every respect of the apparatus without needing to extensively read the user-manual.

The password management, hides some functions and prevents tampering with the most critical options and data to unauthorised people.

The on/stand-by key do not power off the apparatus, which is still locked on frequency and ready to transmit as soon the key is pushed or a remote command is sent.

Some leds signal at a glance proper functioning and warning states.

## REAR PANEL CONNECTORS

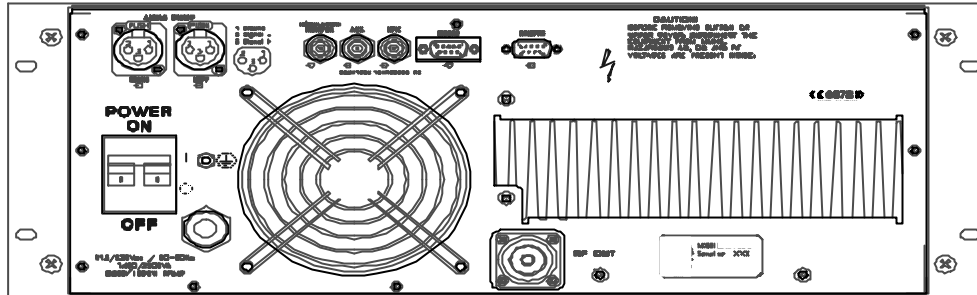

All transmitter inputs and outputs are allocated on the rear panel. They are:

- The audio channels input sockets on balanced female XLR-type connectors
- The wide-band external processed / stereo or composite signal input on a grounded unbalanced BNC connector
- The frequency limited (20k÷100kHz) auxiliary channel input on a grounded, unbalanced BNC connector
- The If modulation output for monitoring, RDS external synchronisation or re-broadcasting purpose, BNC-type
- The inverted wired RS232 DB9 female remote serial control port
- The parallel control port, DB9 male type
- The RF antenna connector, N-type

Note that:

- The hot centre-pin on the "EXTERNAL" BNC input is physically in parallel with the signal + input (pin 3) on the mono/right channel XLR socket. For this reason both connectors cannot be used at the same time.

On the left side of the panel it is located the mains power switch, the power cord and an earth screw for system earthing in addition to the ground conductor on the cord. The power switch trips if an overcurrent condition should occur.

**Please note that the transmitter is usually factory pre-set for 220-240 Vac nominal mains voltage. If requested, 110-120 Vac range must be internally set on the mains transformer board.**

SOFRATEC BROADCAST EQUIPMENT

WWW.sofratec.com - e-mail : info@sofratec.com Tel: +33 4 93 01 99 99 Fax: +33 4 93 01 99 71

## TECHNICAL SPECIFICATIONS

- Frequency range: 87.5÷108 MHz
- Modulation: FM, 75 kHz peak dev.  
180kF3E mono  
256kF3E stereo
- Synthesis step: 10/100 kHz
- Frequency error: <200 Hz
- Frequency drift: <250 Hz over temperature  
<100 Hz/year
- RF output power: 200 ÷ 500W
- Max allowable reflected power: 100W
- RF harmonic products: <-67 dBc, -72 dBc typ.
- RF spurious products: <-85 dBc, -95 dBc typ.
- RF output impedance: 50 ohm
- RF output connector: 7/16"
- Audio/mpx input level: -3.5 ÷ +12.5 dBm  
@ ±75 kHz deviation
- Audio/mpx input impedance: 10 k ohm / 600 ohm  
bal/unbalanced, select.
- Common mode input rejection:  
>50 dB >60 typ. (20 ÷ 15000 Hz)
- Audio input connectors: female XLR type
- Aux channel input level:  
-12.5 ÷ +3.5 dBm @ ±7.5 kHz dev.  
-24 ÷ -8 dBm @ ±2 kHz dev.
- Aux channel input impedance: 10 k ohm
- Linear and aux input connectors: BNC
- Mpx output level: 0 ÷ +10 dBm @ ±75 kHz dev.
- Preemphasis time constant: 0 / 50 / 75 µs ±2%
- S/N ratio, mono:  
≥76 dB 86 typ.(30÷20000Hz)  
≥75 dB 81 typ.(CCIR)
- S/N ratio, stereo: ≥72 dB 77 typ. (30÷20000Hz)  
≥68 dB 72 typ. CCIR
- Modulation distortion:  
<0.05% 0.02% typ. @ 75 kHz dev.  
<0.2% ≤0.05% typ. @ 150 kHz dev.  
(limiter threshold > 150 kHz)
- Stereo crosstalk:  
<-50 dB with external encoder  
<-60 dB (100 ÷ 5000 Hz)  
<-50 dB (30 ÷ 15000 Hz)  
with internal encoder
- Audio channel freq. response:  
30 Hz ÷ 15 kHz ±0.1dB
- Out of band filter reject.: >50 dB @ F≥19 kHz
- Deviation limiter: adjust. between 0 and > +7 dB
- Composite input freq. response:  
10 Hz ÷ 100 kHz ±0.1dB
- Aux input frequency response:  
10 ÷ 100 kHz ±0.2 dB
- I/O lines: RF disable, Direct pw, On the air, Alarm  
RS232 for monitoring and control
- Mains supply requirements:  
115 / 230 Vac ±15% 50/60 Hz  
2400 VA / 1800W @ 1000 Wout
- Operating temperature range: 0 ÷ 35 °C recomm.  
-10 ÷ 45 °C max
- Dimensions without handles: 19" 4 un. std. rack  
483 x 177 x 535mm
- Weight: approx. 30 kg.

## CHECK, PROTECTION AND CONTROL SYSTEMS

Block against emission on spurious frequencies

Reflected power

Modulation limiter

High internal or external temperature

Real-time clock and date, with battery back-up

SOFRATEC BROADCAST EQUIPMENT

WWW.sofratec.com - e-mail : info@sofratec.com Tel: +33 4 93 01 99 99 Fax: +33 4 93 01 99 71

## INSTALLATION AND USE

### FOREWORD TO INSTALLATION

Although in most cases no special instruments are required, have skilled personnel install the apparatus. To make best use of the apparatus's capabilities and prevent damage to the unit, comply with the recommendations throughout this manual.

When in doubt, or if any technical problems should arise during the installation procedure, SOFRATEC strongly recommend the apparatus not be tampered with in any way by unskilled personnel and will be glad to supply qualified after-sale service.

The EXB500 has many features of a hi-fi apparatus and should be installed and audio-wired with the same care, avoiding earth loops as much as possible. When these conditions are met, the transmitter performs superbly.

As a rule, the user should not have access to the inside of the apparatus for normal installation and use. Tampering with the factory settings makes the guarantee null and void and might also affect apparatus' performance, causing costly damage.

Before proceeding further, make sure that mains voltage corresponds to the factory-set value (usually 220/240 Vac). In case it differs, jumpers must be internally set on the mains supply termination board of the apparatus as described further on the manual. **This must be done by skilled technicians.**



**WARNING !**

NO ADJUSTMENT OR INTERNAL PRESETTING IS REQUIRED FOR NORMAL OPERATIONS. THE APPARATUS SHALL BE PROPERLY EARTHED AND BE OPERATED WITH ALL THE COVERS CLOSED TO PREVENT ELECTRICAL HAZARDS IN OPERATION AND FULLY COMPLY WITH CE EMI AND SAFETY REQUIREMENTS.

NEVER TOUCH THE INSIDE OF THE APPARATUS WITHOUT FIRST DISCONNECTING IT FROM THE MAINS. DANGEROUS AC, DC AND RADIO-FREQUENCY VOLTAGES ARE PRESENT INSIDE AND BECOME ACCESSIBLE WHEN THE COVERS ARE REMOVED.

**———— MAINS VOLTAGE MAY KILL ————**

SOFRATEC BROADCAST EQUIPMENT

WWW.sofratec.com - e-mail : info@sofratec.com Tel: +33 4 93 01 99 99 Fax: +33 4 93 01 99 71



## **PLACING THE APPARATUS**

Install apparatus in a dry, sheltered but well-ventilated room away from dust, moisture, insects and vermin (mice). Place apparatus as close as possible to the antenna to prevent excessive power loss in the cables. If this is not feasible, use antenna cables of suitable cross-section.

Room size shall be such that the apparatus can be placed in an upright position and that technical personnel can easily carry out routine or extraordinary maintenance. The minimum recommended size is 2.5m x 2m, and 2.2m high when there is no other broadcasting or support equipment nearby.

For the best results the operating temperature must be comprised in the +10 ÷ +35 °C range. Higher temperatures up to +45 °C, while allowed in the specifications, are not recommended as they will reduce the life of the apparatus.

This conditions cannot generally be met when the exhaust cooling air is not ducted outside and is fed back into the room. This is even truer if more than one apparatus is installed in the same location. An efficient ventilation system is thus required in the room. Air exchange in the room shall have a minimum flow-rate of 500 metres cubed per hour or more.

If the apparatus is fitted in a rack system, the back door of the rack cannot usually be fixed in place. If a completely closed assembly is needed, a suitable ventilation extraction unit must equip the system. To aid air ducting, an optional flange may be retrofitted on the ventilation outlet to which a duct can be attached to convey hot air outside. In this case remember that the EXB500 internal fans are low-pressure units: some sort of external air extraction blower is than imperative on the exhaust air duct.

Vents in the walls and any other openings shall be fitted with a metal grating to keep rodents out, and with a dust filter. Make absolutely certain that no water can seep through the vents or the air exhaust duct or antenna-cable grommet, and that the floor cannot be flooded during heavy rainfall. If not impeded by proper air filtering, insects in some location may be conveyed in the internal heatsink, accumulating on it and finally obstructing it, causing overtemperature alarm.

Even moisture and/or dust, when contained in the air or in the room in excessive quantity, may cause condensation build-up in the amplifier. When the system is periodically switched on and off, this can trigger destructive electric arcs and short circuits and thus cause damage that is not covered by the guarantee.

## **WIRING INTO THE MAINS**

The transmitter is powered by a single-phase line. Mains capacity must be at least 3kVA and the nominal voltage is 230Vac. In some countries, where 115Vac is the norm, this voltage must be internally set in the factory or by skilled people before installation. When both the the mains voltages are available, always prefer the higher one, to decrease the power loss on the mains line.

SOFRATEC BROADCAST EQUIPMENT

WWW.sofratec.com - e-mail : info@sofratec.com Tel: +33 4 93 01 99 99 Fax: +33 4 93 01 99 71

Whilst the power supply regulator accepts a wide input voltage (190 ÷ 250 Vac), operation near the lower input voltage on high impedance lines must be avoided: if the line drops more than 10 volt at full load, the low line sense circuitry may trigger an oscillating turn-on / turn-off cycle, which is very dangerous. In this cases adopt an external line stabiliser.

To allow nominal 115V mains operation (100 ÷ 130 Vac), some jumpers must properly be set on the input transformer terminal board, internally in the apparatus. To do that, the power cord must be disconnected from the mains, the top cover must be removed and the transformer voltage terminals must be accessed.

With reference to the general electrical diagram in the proper section of the diagram and the local internal layout, as below shown, preset the jumpers according the following table:

Jumper/wire	115Vac	230Vac
JP1	TB1-A3 to A6	TB1-A3 to A4
JP2	TB1-B4 to B3	TB1-B4 to B1

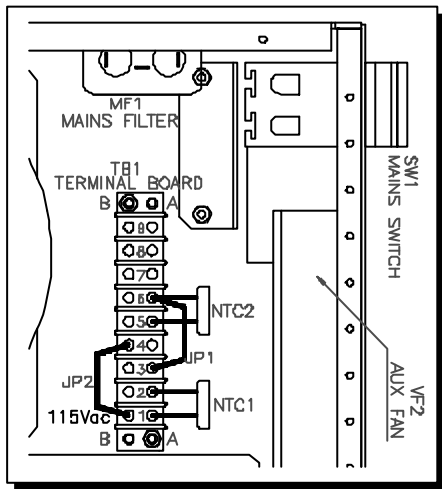

115Vac Terminal board arrangement

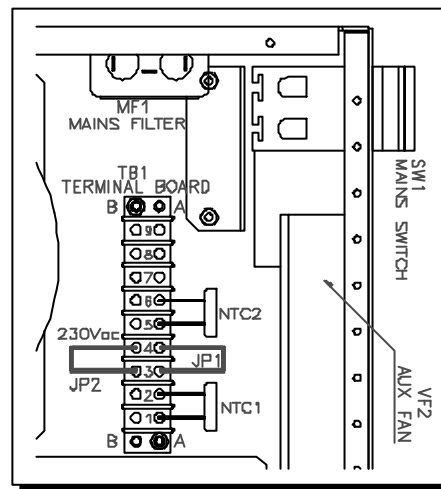

230Vac Terminal board arrangement

To ensure proper operation and comply with the safety regulations, efficient earthing is required. Use the yellow/green lead in the power cable. The cable's neutral lead is blue. Never connect the earth to the mains' neutral lead.

The cable connecting the EXB500 mains input terminal block to the external board should consist of leads of adequate cross-section. Recommended values are 1.5 to 2.5 mm squared for 230Vac operation and 2.5 to 4 mm squared for 115Vac.

Do never switch the apparatus on without antenna connection, even when no RF drive is on.

SOFRATEC BROADCAST EQUIPMENT

WWW.sofratec.com - e-mail : info@sofratec.com Tel: +33 4 93 01 99 99 Fax: +33 4 93 01 99 71

## SYSTEM CONNECTION

- 1) Connect the N-type output connector, marked "RF OUT" to the antenna or successive RF amplifier with top-grade 50-ohm shielded cable.  
Low-attenuation type cable must be used for antenna connection: in this case we suggest Celflex or similar 1/2" cable. Bigger cables must be connected with smaller section pig-tails, to avoid mechanical stress on the output connector.
- 2) Connect the LF inputs as required for operation and detailed in the following chapters for various situations. If needed wire the serial and/or parallel remote control I/O ports as required, or jump this step to a subsequent moment.
- 3) Switch-off the mains rear switch and connect the transmitter to mains and ground system.
- 4) Before turning on the transmitter in the system, pre-set if possible frequency and power separately on a dummy load, to avoid system problems at the first turn-on of the equipment. Refer to the appropriate programming section of this manual for the procedure, if not known.
- 5) Turn-on the rear panel mains switch, then push-on the front panel on/stand-by switch to operate the transmitter and check that:
  - All leds and the display briefly light on and off for the initial check.
  - The yellow "STAND-BY" led turns off, correspondingly turning on the "ON" green led on the cap of the stand-by switch.
  - The green "Local" led must light immediately and the upper green "Lock" led must also light up after some seconds, when the frequency is locked.
  - When locked the RF power will rapidly increase to the pre-set level in a mild ramped mode
  - When the preset power is reached, the "On the air" led will light completely, if the power is set >50W. Till that moment it will turn off and on, signalling the RF power is on but not correct.



The apparatus is now functioning in the pre-set mode, delivers power and can be accessed to be programmed or simply to monitor its functions with the keyboard and the front panel display.

The first request at the turn-on will be entering the password for the required level of authorisation/security. The apparatus is factory pre-set with the first 2 levels disabled: this will permit to set most of

SOFRATEC BROADCAST EQUIPMENT

WWW.sofratec.com - e-mail : info@sofratec.com Tel: +33 4 93 01 99 99 Fax: +33 4 93 01 99 71

the operating parameters, including power, frequency, input levels, clock and date. Some more critical parameters will require the upper 3rd level: be sure to know it if you need this access.

In case the passwords are disabled as factory preset, repeatedly press "ESCAPE" key to access to keyboard functions

THE TRANSMITTER WILL ALWAYS TURN-ON IN THE SAME STATE AS IT WAS IN THE LAST TIME IT WAS TURNED OFF FROM MAINS, I.E. POWER, FREQUENCY AND EVEN ON OR STAND-BY CONDITION. AS SOON YOU TURN-ON THE REAR PANEL MAINS SWITCH BE PROMPT TO THAT, EVEN WHEN JUST FACTORY DELIVERED.

- 6) The first task to manage when turning on the apparatus as factory delivered is to set-up the passwords. At least the 3rd (the highest) level must be **immediately** changed: if any unauthorised people change it or you loose it, there is no way to change it for security reasons and the apparatus may become unmanageable. **Gaining again access to the apparatus will require factory reprogramming or changing of the internal CPU.**

For this reason be sure to write down and keep it **immediately** in a secure place: **there is no way to read it** after you have programmed down and confirmed.

For practically any parameters that may require some setting in the field, the 2nd level password is enough and may be used for any standard service requirement. The main purpose of the existence of the 3rd level is a security assurance for the user if he loses control on the lower password levels.

- 7) If not already done, adjust frequency and RF power as required and check reflected power on the transmitter display. To this aim search for RF power menu and read the corresponding value of direct and reflected output power.

For proper operation, the reflected power reading should typically be less than 10% of the direct power value, 100W max. Any higher reading may indicate that the antenna or the output connectors are not properly connected or functioning.

- 8) Check and/or set clock and data and all transmission parameters as required, i.e. channel sensitivity and deviation, mono/stereo, preemphasis etc. Refer to the appropriate section of the manual.

## LF CONNECTION AND PRESETS

### **LF wiring and impedance selection**

EXB500 supports balanced or unbalanced signals with selectable input impedance.

The audio inputs are basically balanced and have selectable 600/10k ohm resistive impedance, factory pre-set at 10k ohm. They can be connected to the balanced output of a professional mixer or to the unbalanced one of a cheaper unit without appreciable degradation.



BNC connector, marked "MPX", which is internally parallel wired with the "RIGHT" channel connector: for this reason it is not possible to connect signals to these two connectors at the same time. Higher impedance position is 5 kohm in this case too.

Connect this input with a 50-ohm (RG58) cable for a few metres' distance; if the distance exceeds several tens of metres, use 75-ohm (RG59) or 92-ohm (RG62) cables.

The auxiliary-channel connector is also of the grounded BNC female type. Use 50-ohm (RG58) or 75-ohm (RG59) cables to connect to the driver. The same applies to the monitor "MODULATION" output, if needed

### **Pre-emphasis setting**

Low frequency mono and stereo channel signals have to be adequately "pre-emphasised". Standard preemphasis time constant is 50 and 75 $\mu$ s, the former being usually factory pre-set. Check whether this is correct for your country (it is usually correct for any European country and most of the Pacific and South American areas). It is not correct for USA standards, which require 75 $\mu$ s.

If above correction is needed, simply set it on the "mode" frame of the transmitter menu, which also includes mono/stereo operation and frequency. See appropriate section further on in this manual.

### **LF input level range, setting and requirements**

In the following paragraph we will refer to 0 dBm as the audio signal which produce 1mW on 600 ohm, i.e. a 775 mVrms / 2200 mVpp sine. Irrespective of the impedance and the non-sinus form of the signal, we will continue to assume 0 dBm as a LF signal whose peak is + (or -) 1100 mV.

In the same way, when talking of the modulation, we will generally assume 0 dB as the signal which produces 100% maximum allowed modulation, i.e. 75 kHz deviation.

There is no absolute worldwide standard regarding LF peak level as modulation signal for a transmitter, nor for the mean deviation. Many Broadcasters use 0 or +6 dBm as LF peak level for 100% modulation, USA often uses +10 dBm.

Many European countries specify +6dBm for 40 kHz deviation (which is assumed to be a "mean" modulation). This allows for 5.5 dB headroom to 75 kHz (max) deviation, i.e. +11.5 dBm for 100% modulation.

A higher level minimise system and ambient noise. A level too high may over-stress the input circuitry of the transmitter, reducing the dynamic distortion-free range over the nominal level (headroom). It may also be costly to produce with the required quality.

For this reason SOFRATEC recommend, whenever possible, to adopt +6 ÷ +11.5 dBm as nominal peak level for audio modulation purpose.

SOFRATEC BROADCAST EQUIPMENT

WWW.sofratec.com - e-mail : info@sofratec.com Tel: +33 4 93 01 99 99 Fax: +33 4 93 01 99 71

EXCXXX5 transmitter series allow an input LF level on the main channel/s ranging  $-3.5 \div +12.5$  dBm to be set for 100% modulation, with almost no difference in modulation performances, if high quality signal is provided. Even at the higher level, at least +6 dB headroom is additionally allowed: i.e. up to 150 kHz deviation, with no distortion. Obviously this deviation is not allowed by any broadcast standard and the limiter threshold in this case should be set at its maximum to permit undistorted performance.

The auxiliary channel's level ranges  $-12 \div +4$  dBm to produce 10% modulation, i.e. 7.5kHz deviation. Consequently typical input levels for an SCA-type signal (10% max. admissible deviation) are  $0.2 \div 1.0 V_{\text{rms}} / 566 \div 2830 \text{ mV}_{\text{pp}}$ , when the input is set between -11.5 and +2.5 dB. All the same, an RDS-type signal could be accommodated in the  $0.052 \div 0.33 V_{\text{rms}} / 150 \div 930 \text{ mV}_{\text{pp}}$  level range, to produce the standard peak deviation of 2 kHz, as above. In case a higher deviation is required for RDS (some broadcast authorities set it to 3 or even 4 kHz deviation instead of 2kHz standard) a higher signal level or sensitivity preset is needed.

Regulating the nominal input level for 0 dB modulation on the transmitter is an easy task. From the proper menu field it may be seen varying the modulation in real-time with the level adjustment, in 0,5dB steps. The modulation is reported as deviation in kHz and in dB, referred to 75kHz.

In this field, the reported deviation includes any other auxiliary signal as pilot tone, when in stereo, and RDS or SCA signals contemporary applied. To measure only the audio channel signal, go to the Left/Right level menu

The auxiliary channel level is equally easy to set, being measured in dB and in kHz. Remember that, in this case, 0dB corresponds to 7.5kHz deviation, i.e. 10% max allowed total modulation. The typical level for RDS so being -11.5dB for 2 kHz deviation. This menu field accounts only for deviation due to auxiliary signal. To see the added effect on the total deviation, go to the MPX menu.

Due to the inherent characteristics of the RDS signal and the measuring sampling, the reading is slow to stabilise in case of sudden level variations and tends sometimes to slightly flicker in few tenths of a dB. Allow enough time to stabilise and take the higher deviation reported as the right one.

The transmitter's internal limiter is of the peak-clipping type; this means that as soon as it cuts in, modulation distortion increases sharply. For this reason, the modulation signal should be kept under control to prevent intervention of the limiter. Do not over-estimate this problem: occasional action of the limiter is mostly unperceivable.

The cut-in limiter threshold, when enabled, is factory pre-set to +2.5 dB (100 kHz peak value). It may be set from 0 dB (75 kHz) up to +7.1 dB (170 kHz). This threshold value is mostly specified in the various national standards, and tolerance to short over-modulating peaks varies from country to country. Some countries do not permit the user to disable the limiter or change the level. Note that the limiter action begins slightly after the pre-set level, with no action at all till that. The difference between the threshold level and hard clipping is some 0.5dB.

In any case, the modulation peak value that is internationally admitted for FM is 75 kHz for peaks that are not extremely short. For this reason, the limiter's cut-in threshold should never be too high. It

SOFRATEC BROADCAST EQUIPMENT

WWW.sofratec.com - e-mail : info@sofratec.com Tel: +33 4 93 01 99 99 Fax: +33 4 93 01 99 71

is highly recommended to use an external multi-band limiter to optimise modulation, with higher tolerance for any audio-signal peaks. Such devices momentarily reduce the amplifier circuits' gain if the threshold is exceeded and prevent severe, significant distortion.

Any external compressor, limiter or audio meter must be frequency compensated with the same time constant of the pre-emphasis to modulate or monitor deviation properly.

Therefore the audio level shall be constantly and correctly monitored and adjusted to prevent, as much as possible, the internal limiter from cutting in. On the other hand, the audio level should be as high as possible, to achieve the best signal/noise ratio on reception.

The tendency to over-process audio signals is common in many local broadcasting stations: some sort of processing is advisable and we recommend using a top grade multiband compressor, but not to compress the signal too much as this impairs the original dynamics.

The audio response of the EXC105 transmitter is extremely flat, without any perceivable loss on low and high audio frequency: for this reason large frequency alterations of the audio signal supplied by using a so-called "frequency equaliser," are not advisable. An increase of the low and high frequency contents of the audio signal by more than a few dB can cause general degradation of modulation dynamics and improper functioning of the limiter.

### **RS232 port**

The RS232 port manages only Tx, Rx and Return data signals, with no handshake. Being the two former signals inverted wired to the port, it needs a simple straight wired serial cable with appropriate connectors to connect to a PC. Usually a female DB9 or DB25 female goes to the PC port and a male DB9 connector at the transmitter end. Appropriate software is needed for communication. Do not connect the cable with either transmitter or PC on.

### **Parallel REMOTE port**

This port accommodates some lines for simple direct control / monitor on a DB9 male connector. They are:

- Pin 1, 5, 8 *Ground*.
- Pin 2, *On The Air*: a +12V/10k $\Omega$  signals that the transmitter deliver substantial RF power.
- Pin 3, *Direct power*: a signal proportional to direct power is present, with a pseudo square law. Range is 0-5Vdc / 1k $\Omega$  impedance. On EXB500 5V stands for 1500W.
- Pin 6, *RF enable*: a shorted circuit to ground disables RF. signal level  $\approx$  +10V/1mA.
- Pin 7, *Alarm*: logic low signal means alarm. Correct functioning is signalled by +12V/10k $\Omega$ . Maximum current sinking capability <10mA.



## OPERATION

### **Mono Broadcasting, from a monophonic audio source through main mono channel:**

- 1) Wire the "right" (or mono) input connector to the corresponding audio source as described in the "system connection" section. No connection to the "left" channel input is needed. The signal runs through the channel processor and is 15-kHz filtered and pre-emphasised.
- 2) Select the "MODE" command menu (cf. relevant section on the manual) and select "MONO R" operating mode. Confirm or change also 50 or 75 $\mu$ s preemphasis as required.

### **Mono Broadcasting, from a stereophonic audio source through the optional internal stereo-encoder:**

- 1) Wire both the "left" and "right" input connector to the corresponding audio source as required for stereo transmission. The audio signals will run through the channel processors and will be 15-kHz filtered and pre-emphasised on both channels. The internal stereo-encoder will blend the stereo input source to transmit in mono. In this case the transmitter is already preset for stereo operation if needed, simply reversing transmission mode to "stereo".
- 2) Select the "MODE" command menu and select "MONO L+R" operating mode. Confirm or change also 50 or 75 $\mu$ s preemphasis as required.

Note that it is possible, acting on the internal stereo-encoder, to blend the left and right channel or select only one of them, without changing the modulation sensitivity. Refer to the stereo-encoder description to do that.

### **Mono or Stereo Broadcasting from a Radio-Link Receiver or an External Encoder:**

- 1) In this case, the signal is already multiplexed and pre-emphasised. Use the "MPX" If input. The signal skips the coding and filtering stage and therefore is not pre-emphasised.
- 2) Select the "MODE" command menu and select "EXT MPX" operating mode. While it is anyway advisable to select the proper preemphasis time-constant as required for your country, in this position this selection is not influent.

### **Stereo Broadcasting from a stereophonic audio source through the optional internal stereo-encoder:**

- 1) Wire the XLR-type modulation input connectors, marked "Left" (channel) and "Right" (channel), to the output of the two channels from the mixer or stereo source. They will be internally 15-kHz

SOFRATEC BROADCAST EQUIPMENT

WWW.sofratec.com - e-mail : info@sofratec.com Tel: +33 4 93 01 99 99 Fax: +33 4 93 01 99 71

filtered and pre-emphasised

- 2) Select the "MODE" command menu and select "STEREO" operating mode. Confirm or change 50 or 75 $\mu$ s preemphasis as required.

#### **Operation with a RDS or SCA Encoder:**

- 1) Wire the BNC-type "Aux" connector to the output of the RDS or SCA Encoder. If the internal optional stereo-encoder is used, wire the "MODULATION" BNC output to the pilot-tone synchronisation input of the RDS encoder, if present.
- 2) Select the "AUX" command menu and push "ENTER" to vary the channel sensitivity. Adjust both transmitter sensitivity and/or the level of the external generator for the deviation required, as explained in the previous manual sections. Consider that 0dB modulation reading (not the input level) in this field means 10% total modulation or 7.5kHz deviation, i.e. the standard setting for a SCA auxiliary channel. In the case of RDS, a reading of -11.5dB or 2kHz is the correct value of modulation.
- 3) Total modulation and deviation may be read in the "MPX" display field, with the addition of any other composite signal contemporary present.

#### **Modulation Adjustment with broadcast signal:**

Check the overall modulation level for adequacy, as follows:

- 1) Select the display menu field "MPX": the total modulation will be displayed, both in dB and as deviation in kHz. An analog moving bar and a digital peak reading are contemporary shown.
- 2) Send a sufficiently constant musical signal to modulator input, check that the measure hovers around 0 dBm and moves higher during signal peak only and by no more than 1 or 2 dB. For any other reading, adjust the mixer's "MASTER" volume until the above conditions are obtained. The red "Limiter" alarm LED should never or rarely light up, as this would indicate distortion.

If the limiter is set just above 75 kHz, the red LED will light up above 0dB and the modulation measured will never show a much greater value. Factory pre-set is 100 kHz (+2.5 dB).

#### **Check of Pilot tone on Stereophonic Transmission:**

In case of internal stereo-encoder, no allowance is externally provided to change the pilot tone level, which is internally pre-set for 9-10% of modulation, i.e. -21  $\div$  -20dB or 7  $\div$  7.5kHz deviation. In case the stereo multiplex signal it is provided by a separate external stereo-encoder, it must be measured in

absence of audio modulation and any other auxiliary signal as below described:

- 1) Disconnect any signal from the external stereo-encoder input and any RDS or SCA signal.
- 2) Select the display menu field "MPX" and check the pilot tone, which must be now the only signal present. The standard level is that previously stated, i.e. 9-10% or -21 ÷ -20dB, and may be adjusted accordingly on the external stereo-encoder to suit the request.
- 3) Reconnect any previously disconnected signal as done.

**Very low power level transmission:**

EXB500 transmitter is not suggested for use at power levels less than 250W and definitely not specified at <100 Watt, as with some power and frequency combinations (usually at less than 20 Watt), some sub-harmonic and/or spurious signals may be generated and the power level stability is not so good as at higher power. In addition it may be dangerous to use a transmitter which may generate a very higher power level if improperly set.

So were low power level transmission was imperative, preset it very carefully and pre-set also the maximum output power which may be adjusted by main regulation: the software permits to adjust the max RF output level (cfr. relevant section in the manual). Carefully verify with a spectrum analyser that the transmitter is correctly functioning at and just below the operating power.

The installation of the transmitter is thereby completed. Many other monitoring and control facilities are provided by the internal display and software and are remotely accessible. Navigation through the menu driven software is suggested and encouraged to gain confidence with the options: no extensive training is needed for the most common options. Nevertheless some options are hidden for security purpose and require always the password. Read the relevant section of the manual to know all possible functions which are provided and pre-settable.

SOFRATEC wishes you success in your work and remind you that they are always available for further information or to tackle any specific problem.

**OPERATION WITHOUT THE ANTENNA OR WITH A FAULTY ANTENNA CONNECTION MAY CAUSE DEGRADATION AND POSSIBLE DESTRUCTION OF THE FINAL STAGE. THIS FAILURE IS NOT COVERED BY THE GUARANTEE.**

SOFRATEC BROADCAST EQUIPMENT

WWW.sofratec.com - e-mail : info@sofratec.com Tel: +33 4 93 01 99 99 Fax: +33 4 93 01 99 71

## COMMANDS AND PROGRAMMING

The transmitter permits exhaustive control of all transmission parameters and complete programmability and monitoring facilities through the various software controls via the front panel keyboard and display. The same functions are remotely addressable with proper software, which is not included as a standard option other than some simple demo programs.

For a description of remote capability see the proper section on the manual. In this section we will examine the front panel menu-driven operational capability.

## PASSWORD ORGANISATION

The password organisation is set in 3 security levels, each with its own password. A higher level permits to change the lower levels authorisations and passwords.

The password is composed by 4 alphanumeric characters, including extended capital and lower case ones and several special symbols. We suggest using a wide range of characters as the security level raises, to increase the possible combinations. No password is ever shown: it is always masked by dummy characters as "..." or "\*\*\*\*". Nevertheless it may be always changed with the higher level authorisation. Here is the purpose of each level:

Level 1: Lower security level. It is needed to access to most of the monitoring and control menu fields, not permitting to alter or programming any operating parameter. It is set to "off" state as default, permitting to anybody to navigate freely through transmitter's monitoring menu information. SOFRATEC suggests leaving it in this state if a high privacy level is not needed.

If set to "on" it will show the default menu field #00 (c.r. menu tree), requiring password for any other information or pre-set. Failure to insert a correct password of any level will impede any other access to the commands for the time-out length (usually 3 minutes).

No change to the functioning mode is done in case of incorrect password input. No information is available on the display regarding the transmitter functioning.

Level 2: Service level. This password is needed for any functioning set-up as frequency and power, sensitivities, clock and date etc. Its use is reserved to service technicians who need wide access to the transmitter presets and functions.

While the default factory state is "off", SOFRATEC suggests changing the default state and password immediately at the first power on, to prevent to unauthorised people to tamper with transmitter commands, if the default word is known or the state is set to "off".

Level 3: Highest security level. It is always "on" by default and reset anyway to "on" after the display time-out, for security purpose. Its knowledge is deserved only to **very few** people and must be immediately registered after setup and kept in a secure place: **there is no way to read**

it after you have setup and confirmed on the transmitter.

This password must be **immediately** changed at the first pre-set of the apparatus: if any unauthorised people tampers with it or you loose it, there is no way to change it if you do not know the correct word for security reasons and the apparatus may become unmanageable. **Gaining again access to the apparatus will require factory reprogramming or changing the internal CPU.**

For practically any parameters that may require some setting in the field, the 2nd level password is enough and may be used for any standard service requirement. The main purpose of the existence of the 3rd level is a security assurance for the user if he loses control on the lower password levels.

Only very few critical parameters, like limiter permission or control require this password, as in some countries this functions are not allowed to be freely chosen.

### FACTORY DEFAULT PASSWORDS

These are the factory default password:

Level 1:	<b>P001</b>
Level 2:	<b>P002</b>
Level 3:	<b>ABCD</b>

For what previously said, be sure to change at least the 3rd and possibly the 2nd level as soon as you receive and turn on the apparatus.

For security purpose the 3rd level password may be factory changed from the default value before the transmitter is shipped, in consequence of a specific final customer request.

### MENU AND COMMANDS DESCRIPTION

The hierarchical tree of the menu is depicted in the following table, with a small number near the left side of each field for easy reference. In the following pages we will examine each menu field and option.

All of the first column fields require the first level password authorisation to be navigated. Similarly practically all the second column fields require the second level authorisation, as some in the third column. The third level is required only by some functions in this last column.

Navigation through the menu fields is quite straightforward and natural, with the direction key. "Up" and "down" key vertically scroll the fields, while the "left" and "right" key horizontally scroll the menu. Moving to the right may be impeded by the password permission, while returning to left is always possible.

SOFRATEC BROADCAST EQUIPMENT

The "enter" key changes from scrolling to programming mode, if allowed in the field. Another push



EXB500 - USER AND MAINTENANCE MANUAL - rev.1.0 - 03/02

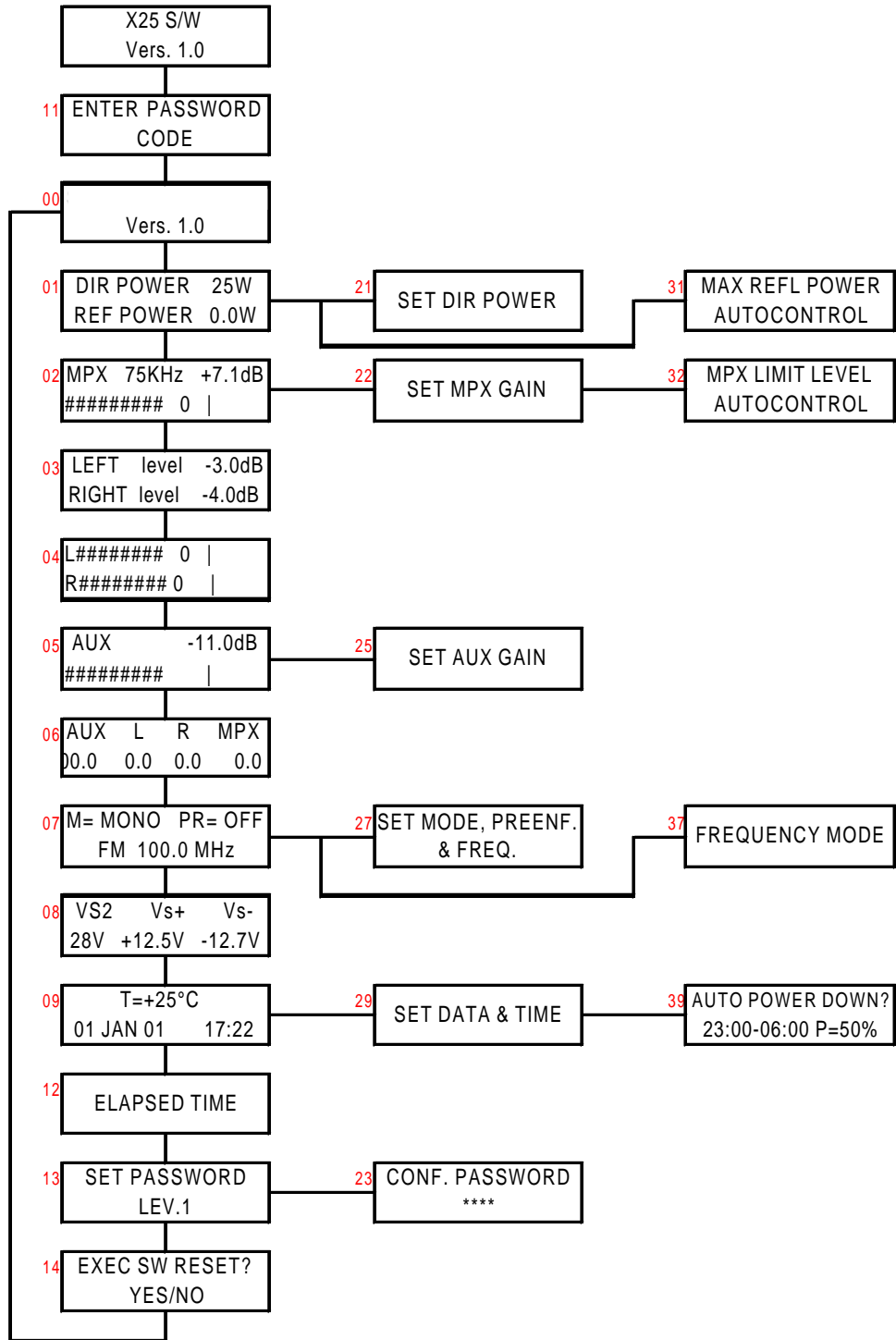

SOFRATEC BROADCAST EQUIPMENT

WWW.sofratec.com - e-mail : info@sofratec.com Tel: +33 4 93 01 99 99 Fax: +33 4 93 01 99 71

on the "enter" key will confirm the input data. When in program mode, the up and down keys will change the character, while the left and right key will move the cursor on the field. Pushing on the "escape" key will abort the input while repeated escape commands will reset the menu field to the default one (#00).

A local input time-out will automatically escape the command mode resetting input data if this is not confirmed in 60 seconds after the last variation.

Few minutes of experiments will enable most users to gain confidence with control keys and menu and to be able to access all main features of the transmitter, without any previous training.

Anyway it is impossible to discover hidden functions without the proper password permission.

Hierarchical menu tree

SOFRATEC BROADCAST EQUIPMENT

WWW.sofratec.com - e-mail : info@sofratec.com Tel: +33 4 93 01 99 99 Fax: +33 4 93 01 99 71



**Start menu**

The start menu field is the unnumbered one on the top of the menu tree. It is shown only when the apparatus is turned on from mains or software reset. It will show the software version and the initialization step, when all the leds and the display will be turned on and off for testing purpose. Any subsequent key input will turn this menu field to the next, which requests a valid password code.

**Menu #11: Initial Password**

**ENTER PASSWORD**  
.....

This field requests to input a valid password code. When the input is confirmed by the "enter" key, the word will be compared with the memorised passwords table and, if recognised, the corresponding security level will be allowed. If the password is incorrect or the input is terminated by an "escape", the password will be signalled as invalid and the security level allowed will be that actually in memory, i.e. 0 (no permission at all), 1 or 2.

If the security level is pre-set to "off" for the 1st and the 2nd level as factory pre-set, there is no need to input any password to freely navigate in the menu tree and to change most parameters.

When the password is recognised as valid and the corresponding level is displayed, press on escape key will turn on the default menu field #00.

**Menu #00: Default Message**

**SOFRATEC - 1 -**  
**X25 SW rev. 1.0**

This field shows the default message and the software release. It is the field that will be initially set or to which it will return back after repeated escape commands.

If authorised by the 3rd level permission, going in the command mode pushing "enter", will permit to edit the first row of this field with a custom 20 characters long message e.g. the following organisation name:

**NORTH-WEST RADIO**  
**X25 SW rev. 1.0**

**Menu #01: Direct & Reflected Power**

```
Dir Power: 1002 W
Refl Power: 26 W
```

This field shows the direct and reflected power actually delivered.

Going in the command mode, with the 2nd level password authorisation, will permit to set a new direct RF output power. See menu #21.

**Menu #02: Multiplex Signal Level (Output Modulation)**

```
MPX 75.0kHz + 0.0dB
##### 0 |
```

This field shows the actual peak modulation in dB referred to 75kHz and as deviation in kHz. A pseudo-analog moving bar will contemporary change according with the modulation, leaving a peak mark at its end for 1 or 2 seconds. A vertical bar (|) on this line marks the 0dB position.

Command mode, with the 2nd level password authorization, permits to set LF input channel sensitivity. See menu #22.

Right key instead permits to access to limiter setup and threshold. See menu #32.

**Menu #03: Left & Right Signal Level in dB**

```
LEFT level - 3.0dB
RIGHT level - 4.5dB
```

This field shows the actual left and right peak modulation in dB referred to 75kHz.

The reading is adequately accurate with real audio signals. Some steady state test tone especially at very low audio frequency may beat with the discrete ADC conversion sometimes producing reading uncertainty (*aliasing*). In this case the MPX level reading will anyway produce correct overall modulation measure.

**Menu #04: Left & Right Signal Level as analog moving bar**



This field shows the actual left and right peak modulation as two moving bars. A vertical line marks 0dB position and the same considerations as in the previous menu are still valid.

**Menu #05: Auxiliary Signal Level Modulation (SCA, RDS)**

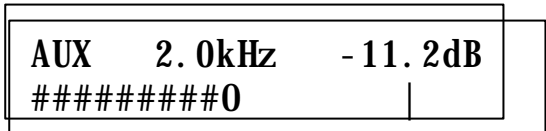

This field shows the actual modulation due to an auxiliary SCA or RDS signal in dB referred to 7.5kHz or 10% of max peak modulation. Usual level for SCA signal is 0dB (7.5kHz) while standard RDS modulation needs to be set at -11.5dB (2kHz).

Command mode, with the 2nd level password authorization, permits to set auxiliary input channel sensitivity. See menu #25.

**Menu #06: Aux, Left, Right and Mpx level in dB**

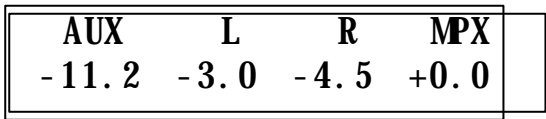

This field contemporary summarise the actual modulation in dB due auxiliary, left, right and multiplex signal as seen in their own menu fields.

**Menu #07: Transmission Modes and Frequency**

**STEREO PR=50us**  
**FM 102.43 MHz**

This field shows the transmission mode, i.e. "EXTMPX", "MONOR", "STEREO", "MONOL+R", the latter 2 modes allowed and automatically recognised only if the optional stereo-encoder board is internally present. It also displays the preemphasis time constant and the transmission frequency.

Entering in command mode, with the 2nd level password authorisation, permits to set every of this transmission parameters. See menu #27.

Pushing "right" key will allow access to change the frequency step between 10 and 100kHz. See menu #37.

**Menu #08: Internal Voltages**

This field shows the internal regulated voltages. In the EXB500 Vs2 is comprised between +18 and +22V, depending on factory adjustment. Vs+ is +12.5±0.3V, Vs- is -13.0V (+1/-3V). A marked difference from these values, may indicate mis-fuctioning.

<b>Vs2</b>	<b>Vs+</b>	<b>Vs-</b>
<b>+20.2V</b>	<b>+12.4V</b>	<b>-12.9V</b>

**Menu #09: Temperature, Data and Clock**

<b>T(A/H):</b>	<b>+30°C</b>	<b>+40°C</b>
<b>01 JAN 02</b>	<b>17:22:10</b>	

This field shows the internal temperature, the actual data and clock. To set data and clock it is required to go in command mode, with the 2nd level password authorisation. See menu #29.

Two temperature sensors read the ambient (A) and the output stage heatsink (H) temperature. The ambient temperature is really that of the exhaust ventilation air and it is taken just behind the front panel. It is usually 2 - 3 °C higher than the external temperature at full output power: i.e. nearly +47 °C assuming an external temperature of +45 °C (the maximum allowed).

The heatsink temperature is usually 10 -13°C higher than the ambient, at maximum power.

Being the maximum allowed temperature limit +45°C, the transmitter progressively reduces its output power when the ambient temperature is reported higher than 55°C or the heathsink is higher than 65°C. There is 5°C overtemperature range in which the equipment is allowed to work at reduced performance. In addition, the equipment may reliably work in an ambient which is even 10°C higher

SOFRATEC BROADCAST EQUIPMENT

WWW.sofratec.com - e-mail : info@sofratec.com Tel: +33 4 93 01 99 99 Fax: +33 4 93 01 99 71

than the maximum nominal range, at less than maximum output power or for reduced lengths of time.

Take present that the higher the ambient temperature, the lower the MTBF. As rule of thumb the life is halved each 10 °C the temperature is increased. Assuming 10 years operating life at +25°C, which is not unrealistic, it may become 2.5 years at +45°C.

**Menu #12: Elapsed Time**

**ELAPSED TIME**  
**000356 HOURS**

This field shows the elapsed time whether the transmitter is on the air or in stand-by with the mains applied. There is no way to change the reading.

**Menu #13: Password Management**

**PASSWORD LEVEL X**  
**code=\*\*\*\* status=OFF**

This field shows the password status and permits to change the code and/or the status in command mode, when in possession of the necessary level authorisation for that level or a higher one. No code is ever shown and no access is permitted to a level higher than the current authorisation.

If the password is unknown, lost or tamperers changed it, it is possible to change status and code when in possession of the higher password. In this case the lower level password code must be changed and confirmed: no possibility still being to know what was the old password. This means that it is always possible to change the 1st or 2nd level password, even if they are unknown, if respectively the 2nd or 3rd level password are correctly set.

If the code or the status is changed, it is always required to confirm the correct password for that level.

In case a lower password permission is actually set in regard to the needed action, it is possible to input the higher level password either performing a software reset, if permitted, or turning off and on the mains voltage through the rear mains switch or an external switch.

The 3rd level authorisation, when set, will stay valid only till a display time-out is performed, i.e. usually 3 minutes after the last command. Simply navigating through the menu or performing some action will prolong the time-out.

If the password status is set to on for the level 1, a hung-up follows after the time-out. This is intentional to prevent unauthorised people from browsing the transmitter parameter. Transmitter performance will be unaffected by this condition. Any attempt to access the transmitter will cause the password request: if an invalid password is entered, it needs to wait for the time-out to permit a new attempt or to remove the mains power to the apparatus, causing a hardware reset. Even in this case, the first request will be a valid password input.

#### **Menu #14: Software Reset**

<p><b>EXEC SOFTWARE RESET?</b> <b>NO</b></p>
--

This field permits to execute a software reset if in possession at least of level 1 password authorisation. The main purpose of this reset is permitting to input a new password level; its action is similar to turning off and on the mains to the apparatus. A software reset will lead to a small interruption of the RF output power which will be re-established in 1-2 seconds, while lock on frequency will not be lost. No transmission or sensitivity parameter is lost in consequence of software or hardware reset.

To execute a software reset the "ENTER" key must be pressed twice

#### **Menu #21: Output Power Set**

<p><b>Dir Power:</b> <input type="text" value="990"/> <b>W</b></p> <p><b>Refl Power:</b> <input type="text" value="22"/> <b>W</b></p>
---

This field derives from #01, in command mode. The direct power value blinks and acting on up and down keys the numeric value varies. The output power will vary in real time. Confirming the final value with an "enter" will write the new setting in the non-volatile memory of the apparatus. Escaping will abort the change. A local time-out will automatically escape the input if not confirmed in 30s from the last change.

**Menu #22: Multiplex, Left & Right Input Level Set**

<b>MPX 75.0kHz + 0.0dB</b> <b>Nom i nput = + 6.0dBm</b>
--

This field in command mode, with the 2nd level password authorisation, permits to set LF input channels sensitivity, i.e. multiplex, left and right channel. Take present that the multiplex and the right signals share the same channel and the sensitivity is set to the same value for both right (or multiplex) and left channel, with a differential error <0.2dB at any level. Allowed range is -3.5 ÷ +12.5 dBm.

The first line of the display shows the actual modulation, while the bottom line shows the input level for 100% modulation. Increasing the nominal input level will accordingly decrease the modulation.

**Menu #23: Password Confirmation**

<b>CONFIRM PASSWORD</b> .....
----------------------------------

This field is displayed when password code or mode is changed on menu #13. It requires to input the same password code as in the current level which is to be changed. Failure to do so will show the following message:

<b>INVALID PASSWORD!</b> .....
-----------------------------------

This display stops input mode for 5 second and than permits to exit (and possibly to try again) with the escape key.

**Menu #25: Auxiliary channel Input Level Set**

<b>AUX 2.0kHz -11.2dB</b> <b>Nom i nput = + 0.0dBm</b>
---

This field in command mode, with the 2nd level password authorisation, permits to set the auxiliary channels input sensitivity. Allowed range is -12 ÷ +4 dBm to produce 10% modulation, i.e. 7.5kHz deviation or 0dB in the upper line of the display.

**Menu #27: Mode, Preemphasis and Frequency Set**

STEREO	PR=50us
FM	102.43 MHz

In this field it is possible to set the transmission "modes" (MONO R, STEREO, MONO L+R, EXT MPX), the preemphasis time-constant (0, 25, 50 & 75 µs) and the frequency in step of 10 or 100kHz as pre-set on the menu #37. The access to this last menu is performed directly from the main frequency menu #07, pressing the "right" key.

Left and right keys change the input fields whilst the up and down keys change the various options or increase/decrease the frequency.

**Menu #29: Data and Time Set**

T(A/H):	+30°C	+36°C
01 JAN 02	17:22:10	

This field is the command mode display of menu #09, with the 2nd level password authorisation and permits to set data and time.

As in the last menu, the left and right keys change the input fields while the up and down keys increase/decrease the date and time.

**Menu #31: Maximum Reflected Power Set**

This field permits to set the maximum reflected power level. Default value is nearly 90W and in any case this power is hardware limited to 100/120W for security reason.

Auto Control on the lower line is not operative and could be absent in other software releases.

Refl. Pw limit	87 W
Auto Control	OFF

**Menu #32: Limiter Set**

This field, with the 2nd level authorisation, permits to set the limiter action. The right/left keys toggle limiter on and off. The up/down keys vary the threshold level.

Auto Control on the lower line is not operative in some software releases. When it is, it will



dynamically reduce the input sensitivity to allow distortionless limiting if pre-set to ON. Even in this case it will be wise not to exceed the limiter threshold to avoid "pumping" effect on the modulation.

**MPX limit + 7.1dB**

**Auto Control  OFF**

**Menu #37: Frequency mode**

<b>FREQUENCY</b>	<b>MODE</b>
<b><input type="checkbox"/> 100kHz</b>	<b>/ <input type="checkbox"/> STEP</b>

This field, with the 3rd level authorisation, permits to set the frequency step variation between 100 and 10kHz.

**Menu #39: Power-down setup**

This field, with the 2nd level authorisation, permits to preset the "power-down" mode.

If this mode is on, the output power will be automatically decreased to the pre-set percentage in the time period set on the bottom line. The scaled power is approximate and must be tested and/or adjusted before final setup, if critical.

**AUTO POWER-DOWN  OFF**

**23:00 -  06:00 P= 50%**

## SERVICE AND MAINTENANCE

Since the EXB500 is forced-air cooled by an internal low-pressure fan, it is subjected to clogging by dust.

It is therefore recommended to install the apparatus in rooms that are not excessively dusty and sheltered from dust. Place apparatus above floor level on a stable stand/rack, in such a way to permit good ventilation. Depending on the environment it is suggested to internally clean the equipment with a soft brush or compressed air at fixed time intervals, from 6 to 12 months.

Other than this, because of the high-quality materials used in their manufacture, if it is installed as set forth under "INSTALLATION AND USE," it will not require special maintenance for quite some time.

After a few years of continuous service, it is recommended that the apparatus be overhauled in the factory or in a specialised laboratory, where the characteristics can be checked against the initial ones and re-calibration can be done when needed.

It is especially important that the power supply be over-hauled when the apparatus have been working at high temperatures, over 30 / 35 °C.

**Never change the internal calibrations to avoid altering the transmitter declared performances.**

## GUARANTEE

Like all SIEL's solid state equipment, this transmitter carries a one-year guarantee on all their components with the exclusion of the final RF power transistor, which may be damaged by faulty output connections.

This guarantee is null and void if the apparatus is tampered with or if failure is due to improper use, wrong installation or external causes, such as mains overvoltage or excessive moisture in the environment.

This guarantee covers work done exclusively in our laboratories and in those of our agreed representatives.

The goods shall be delivered carriage prepaid to the laboratory and shall be returned freight forward.

This guarantee does not cover any consequential damage due to non-operation or faulty operation.

## SERVICE MANUAL

### INTERNAL DESCRIPTION

The EXB500 transmitter comprise several internal modules, as can be seen in the drawing "General view" and in the "General wiring diagram", both comprised in this manual:

- The CPU controller and display board
- The LF and RF control main-board
- The stereo-encoder module (optional)
- The FM synthesiser module
- The RF driver amplifier
- The RF power amplifier array
- The main regulated power supply
- The auxiliary regulated power supply

For the detailed description of each module on the following pages, always refer to the corresponding electrical diagram, in the relevant section of the manual.



THIS SECTION IS ONLY AIMED TO GENERAL EXPLANATION, REFERENCE AND SERVICE PURPOSE BY SKILLED PERSONNEL. AS EXPLAINED IN THE PREVIOUS SECTIONS, INTERNAL ADJUSTMENTS ARE NOT REQUIRED DURING NORMAL OPERATION. TAMPERING WITH INTERNAL SETTINGS VOIDS THE WARRANTY, MAY HARM THE APPARATUS AND JEOPARDIZE THE GUARANTEED PERFORMANCE. COMPONENT VALUES SHOWN MAY VARY FOR PRODUCTION REQUIREMENTS.

DUE TO THE TECHNOLOGY USED, MOST MODULES AND ESPECIALLY THOSE IN SMT ARE NOT INTENDED TO BE REPAIRED IN CASE OF FAILURE AND MUST BE REPLACED WITH NEW ONES.

SOFRATEC BROADCAST EQUIPMENT

WWW.sofratec.com - e-mail : info@sofratec.com Tel: +33 4 93 01 99 99 Fax: +33 4 93 01 99 71

## THE CPU CONTROLLER AND DISPLAY

This circuit board is basically simple. It contains the CPU, the keyboard and few other circuits which we will briefly discuss.

The CPU has 3 digital 8-bit ports and an analog one. This latter is the interface with the analog signals that must be measured in the transmitter. A fast peak rectifier built around IC4 drives one of these analog lines. All audio or LF modulation plus some steady state signals are multiplexed to its input by IC3, so requiring only one peak rectifier and increasing the number of the analog channels. One analog channel reads the internal temperature through the TR3 sensor, while a second temperature input is performed by the line AN3, for the heathsink temperature sensing.

The simple specialised IC6 performs clock and date functions as a stand-alone unit, backed-up by a battery which keeps circuit active for a long time when the power is removed.

The keyboard switch array is sequentially scanned one hundred times in a second to determine if a key was pushed. IC5, a serial to parallel converter, drives the front-panel leds and the display backlighting with TR2.

The alphanumeric display is a separate module, connected to the board by a small flat-cable. 11 digital lines from the CPU drive this module. The internal board trimmer RT1 regulate the LCD contrast and may be used to change it for different situations. A separate power supply current for the backlight leds is provided by R41 and R42: these resistors become quite hot when the display is full on and their heat someway influence the internal temperature read by TR3.

No other regulation is provided on the board. The precision of the measurements is guaranteed by design by the precision of the components and the reference voltage source IC1.

## THE LF AND RF CONTROL AND PROCESS MAIN-BOARD

This is the most complex board in the transmitter and supports the LF input processing, with level adjustment, audio-pass filtering and limiting. It also carries the RF control section and the I/O interfaces and interconnects the various transmitter modules with flat-cables.

Its electrical diagram is splitted in two sheets for clarity purpose: they will be examined in sequence.

In the first diagram sheet are allocated the I/O interfaces, both the audio and the digital ports and the analog RF control. Let's start to briefly consider each block diagram.

In the upper left side of the diagram are located the audio channels amplifier/buffers made with 6 op-amp sections of IC1 and IC2. Two impedance selector jumpers for the audio channels leads the pack and a protection network made by resistors and diodes protects the inputs from occasional static discharges, as required for **CE** compliance. Four unity-gain active buffers follow and than two balanced to unbalanced signal converters, which drive the electronic attenuator in the 2nd sheet.

SOFRATEC BROADCAST EQUIPMENT

WWW.sofratec.com - e-mail : info@sofratec.com Tel: +33 4 93 01 99 99 Fax: +33 4 93 01 99 71

The last op-amp in IC2 (d), amplify the auxiliary channel input with a -0.1dB upper corner band >>200 kHz and drives the third channel of the electronic attenuator.

On the lower left of the diagram are the RS232 interface (IC5) and the parallel remote I/O active interface with its protection network, built around TR1, TR2 and TR3. A wired or pull-up makes the logic levels <1V as 0 and 10-12V for 1.

On the lower right section of the diagram it is located the RF power controller.

The RF direct and reflected power signals coming from the output directional coupler are amplified by IC3 in two symmetrical circuits.

The direct-power control circuit, built around IC4a continuously drives the RF output stage gain, varying the supply voltage to the RF driver transistor and the regulated voltage of the output transistor. The reflected-power limiting circuit IC4b only acts on the same loop when the IC3b output voltage is greater than the threshold set by the voltage on the R49/R50 network. A third and fourth section of IC4 filter and buffer the signal coming from the CPU and set the reference level for the output power loop. TR4 disable the RF output when the synthesiser is not locked on the correct frequency.

In the upper right section of the sheet it is shown the control bus connector to the CPU, which carries the digital control lines on the lower pins and the analog lines on the upper ones. From this connector comes the power supply too: only +12.5V and -12.5V are used in the board.

Let's now go to the second sheet of this diagram.

Beginning from the upper left side, we find IC8, which makes a 3-channel digitally controlled attenuator. It separately manages left, right and auxiliary channel, while the external multiplex signal is processed in the same channel as the right one. 3 buffers/amplifier follow each channel: IC7a, IC8a and IC12a. The output of the first two amplifiers drive the pre-emphasis stages, whose time constants can be digitally set at 0, 50 and 75µs, through the analog gates of IC9. A limiter stage follows, built around D8 and D9 diodes acting as clippers. By varying the limiter's reference voltage driven by the CPU through IC13a, the limiter threshold level +VI & -VI can be adjusted. RT4, if present, impose a ceiling to the limiter.

The signal is then sent to the stereo-encoder circuit's input sections if present. Contemporary the signal the signal on the mono right channel path is sent to a low-pass filter, consisting of the section built around IC10 and IC11, which attenuates the frequencies above 15 kHz, for operation in mono.

The switch IC14 selects the signal issuing from the non-pre-emphasised input section through R124 or from the pre-emphasis-and-filter section through R128 or from the stereo-encoder through R131. IC12b buffers the chosen signal and mix it with that issuing from the auxiliary channel. When required the diode D17 further limits the resulting total signal. The latter is then sent to the FM modulating/exciting circuit via IC12c buffer circuit and adjusted in level by RT6 as required. A separate section of IC12 separately buffers the modulation signal for monitoring purpose, and sends it to the modulation output connector.

SOFRATEC BROADCAST EQUIPMENT

WWW.sofratec.com - e-mail : info@sofratec.com Tel: +33 4 93 01 99 99 Fax: +33 4 93 01 99 71

IC15 deserialise the digital signal sent by the CPU to control the transmission channels with IC14 and preemphasis action with IC9. Two output lines from IC15 are used to latch the remote output lines "Failure" and "On the air".

### **THE STEREO-ENCODER MODULE**

The encoding circuit uses an 8-step switching technique, which ensures excellent performance with a relatively simple circuit. In addition, by this technique, the first harmonics that are associated with the resulting stereo multiplex signal are the 7th and 9th (266 and 342 kHz); this simplifies the design of the low-pass filter on this signal.

The audio signal is filtered beyond 15 kHz by the two precision active low-pass filters built around IC1 ÷ IC4. It is then buffered by IC3d and IC4c and applied to the encoding circuit comprised in IC8. Another higher frequency low-pass filter follows to remove higher order harmonic products. This filter too is made with highly precise active circuitry built around IC5 and IC6a, b. The latter section (c) of IC6 performs phase equalisation. The four analog switches comprised in IC7 permits to select the mono or the stereo-encoded signal and to slightly vary the encoder gain to adjust for the 90% audio modulation in stereo vs. 100% in mono. Two jumpers on BD1 permit to select either Left or Right or Left+Right channel for mono operation, with no output level change. As factory configured, both jumpers are installed, to mix Left and Right channel for "MONO L+R" operation.

Circuits IC10, IC11 make the encoder's time base; IC9 synthesizes the 19kHz pilot frequency, which is filtered and buffered by IC5a. A separate 1Vpp output is provided on J2 to drive carrier synchronisation on a possible external RDS generator.

### **THE SYNTHESISED OSCILLATOR**

It's a classical phase-locked-loop circuit with 10-kHz step synthesis across the entire FM band.

The very low-noise, fundamental-frequency VCO consists of a FET-oscillator transistor TR5, modulated by the varactor diode set D4÷D7, which also sets the operating frequency. The circuit is sensitivity compensated vs. carrier frequency variation so that its modulation gain varies less then 0.5 dB across the entire operating range.

Modulation distortion is typically lower than 0.03% with over 90 dB S/N ratio in the mono mode in the 30 - 20,000 Hz band.

The RF signal is buffered and amplified by three successive transistors TR6 ÷ TR8, from which is derived the feedback signal to the PLL and the drive signal for the output RF stage. This latter is composed by two small mosfet transistors TR9 and TR10 and attains some 900 mW output level (+29

dBm) over the full FM range. To correctly operate TR9 and TR10 require a gate bias voltage, which is factory pre-set by RT1.

The digital PLL circuit is entirely comprised in IC2, whose frequency reference is derived by a highly precise temperature compensated oscillator (TCXO1) running at 12.8MHz.

To correctly operate on the chosen frequency, IC2 must be serially programmed with complex data. This task is done by the transmitter CPU through 3 control lines.

IC1 either performs loop filtering from IC2 frequency comparator output to the varactor diodes and lock detection. Note that bias voltage is removed from output transistors through TR4 and TR3 to turn-off RF when the PLL is not locked on the right frequency. The control loop was designed to ensure that cross-talk added to stereo-composite signal is below -55 dB at 30 Hz, and is virtually not influent at just slightly higher frequencies.

### **THE RF DRIVER AMPLIFIER**

This stage is designed with one high gain mosfet RF power transistor, which has some 17 dB gain, in a broadband design.

A resistive input attenuator (R2, R3, R4), when present, enhances matching with the preceding stage and contributes to insulate the two stages. A broadband matching network feeds the transistor gate and the other one follows the transistor drain.

The available output power is well over 25W on the whole FM range, with 28V power supply. To limit that power up to nearly 20W, a lower power supply voltage is applied, usually 20V.

The transistor gate is biased by zener network and a resistive trimmer which adjusts the idle current of the transistor. RT1 is usually set so that to provide some 200mA drain current, with +12Vdc control voltage applied and no RF input. Varying the control voltage towards a negative supply progressively disables the amplifier transistor, so effectively acting as an AGC input.

In fact the power management circuit, in a closed loop driven by the output sense circuitry, varies this voltage. This will accordingly vary the output power to obtain the pre-set value and cope with alarm and start-up conditions.

The low-pass section and the directional coupler circuit shown in the electrical diagram and allowed in the board are not always present, because they are not needed for the driver.

## **THE RF POWER AMPLIFIER ARRAY**

This stage is designed with two 500W amplifier modules, coupled with an input splitter and an output combiner. A low-pass is incorporated in the latter together with a directional coupler.

The whole assembly is contained in a fully screened box, which may be accessed from the bottom of the transmitter, removing the bottom cover. A quick description of each stage follows.

### **The input RF power splitter**

The purpose of this simple board is mainly to divide the input RF drive power in two identical signals, one for each power amplifier module, providing a good insulation between each output port (>20 dB, typ. 23 dB minimum on the whole FM band).

This is done by a Wilkinson type printed coupler, followed by the balancing resistor array R21 ÷ R24.

A directional coupler senses the input RF level and RT1 is regulated to provide the overdrive protection circuit trip at the right maximum input level. The board supports also the direct (or forward) and reflected detector sensitivity trimmers, whose input comes from the output board.

Two additional lines support the RF module bias (or AGC) line and the temperature sensing PTC thermistor on the heatsink.

### **The RF power amplifier modules**

These modules are built around a couple of "Gemini type" Mos-fet transistors each one forming a 300W push-pull amplifier.

Discrete Wilkinson-type couplers equip both the input and the output module section, doing the job of dividing and recombining the input and output signals, providing a suitable insulation between the transistors.

A small balancing resistor R1 is mounted on the input splitter, while a much bigger resistor R14 is mounted in the output combiner.

A group of C, R and L RF decoupler and dampening components are mounted on the positive supply line of each amplifier, plus a small value resistor, R12 and R13, for possible separate current detection of each supply leg.

The gate bias is separately adjusted through R15 and R16 on each section. Do not tamper the factory bias preset values!



The full power output of the whole module exceeds 600W, to provide some room for coupling losses on the combining stages of higher power amplifiers, like the same EXB500.

### **The output RF power combiner, LPF and coupler**

This module is symmetric to the input power splitter and is another printed Wilkinson coupler, whose power management capability is obviously much higher than the input board. In this case the power balancing resistors are high power devices, whose centre connection is referred to ground through an inductor, which discharges any static electricity on the antenna up to a relevant amount of power.

The power combiner is followed by a printed low-pass filter, which attenuates the harmonic products generated by the amplifiers.

3 directional sample lines derive two rectified voltages proportional to the direct and reflected output power and a RF signal for external monitoring purposes.

## **THE MAIN POWER SUPPLY REGULATOR**

This module performs an efficient regulation of the raw dc input, nominally 140V  $\pm$ 15% to that much lower, needed by the RF output power modules, nominally 48V. Being its efficiency very high, very little heat is produced in the regulation process. The nominal current capability of the regulator is much higher than requested, and approaches 70A @ 48V.

A control I/O connector on an upper daughter board permits a remote control of the regulator by the apparatus controller, i.e. output on/stand-by, current and voltage monitoring, status prompting and alert.

The regulated voltage is dynamically varied by the ALC control with the output power, to maintain high efficiency at reduced power levels, proportionally decreasing the generated heat amount. The voltage varies in the range 30 to 48V, the higher one being measurable only when the apparatus is set at the maximum output power.

A fast 80A semiconductor-grade protection fuse is screwed on the board: it may be fused by the crowbar protection in case of switching transistor damage. If this happens a first attempt to replace the fuse may be accomplished, after having verified the integrity of the power transistors. Usually something is broken so causing the fuse blow-up.

Reparation of this module in the field is very difficult if any component other than the fuse and/or a power transistor failed. It is suggested to substitute the module with a new one and send back the damaged unit to the factory for inspection and possible reparation.

SOFRATEC BROADCAST EQUIPMENT

WWW.sofratec.com - e-mail : info@sofratec.com Tel: +33 4 93 01 99 99 Fax: +33 4 93 01 99 71

### **THE AUXILIARY POWER SUPPLY REGULATOR**

Even this small power supply regulator is a high-efficiency, low-voltage switch-mode type. Its input is derived by the main nominally regulated +48V.

The main switch-mode regulator is built around IC1, which controls the conduction duty-cycle of its internal series-pass power MOSFET to obtain a  $28.0 \pm 0.1\text{Vdc}$  regulated voltage. The oscillation frequency is fixed, nearly 100 kHz.

L1 and C26/C27 forms the main integration cell, which averages the pulsed voltage at IC1 output. A second filtering cell, L2, C28/C29 further removes high frequency noise contents from the main regulated output.

A 30V zener diode, D8, is in parallel with the main regulated output, for safety purpose. Should the internal switch transistor fail short, D8 would break-down blowing the series input fuse on the board, avoiding more costly overvoltage damages to the rest of the transmitter. It is imperative not to pass the nominal +28.0V (+0.1V max) on the main regulated output, to avoid overstress on this component and consequent failure. Nevertheless in this apparatus, the main regulated voltage is usually set to +20V and limited to 22-23V max, as needed by the RF driver amplifier to deliver 18 to 20W.

Another lower power switch-mode IC regulator derives the auxiliary regulated +12.5V voltage ( $\pm 0.5\text{V}/0.5\text{A}$ , average) and a loosely regulated  $-12.5 \pm 1\text{V}$

The efficiency of the whole circuitry is very high and manages a substantial amount of power versus mains voltage changes, dissipating little energy, so keeping overall temperature low with no extensive heatsinking, required by linear regulators.

**EXB500 TRANSMITTER - FRONT & TOP ASSEMBLY VIEW**

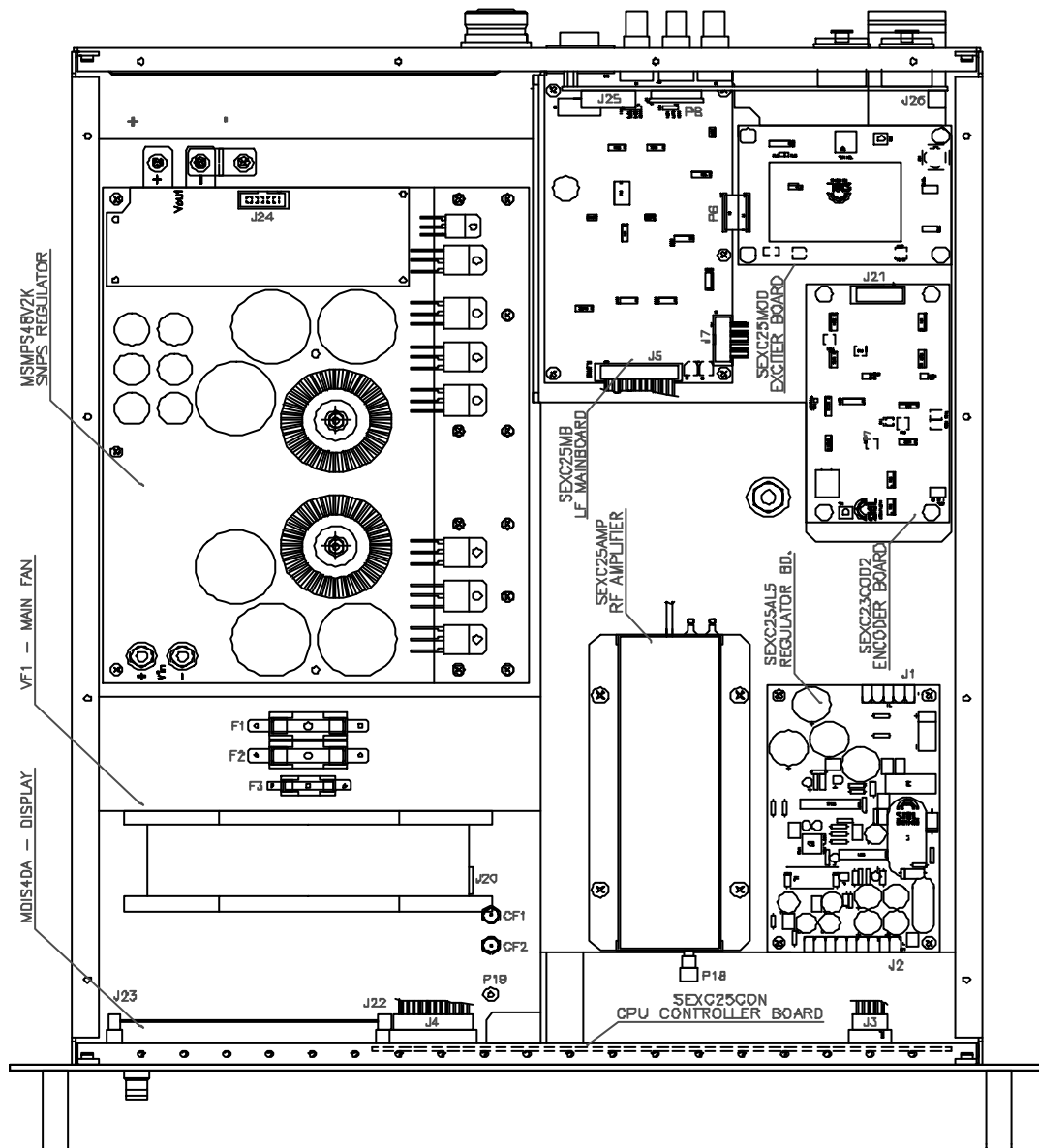
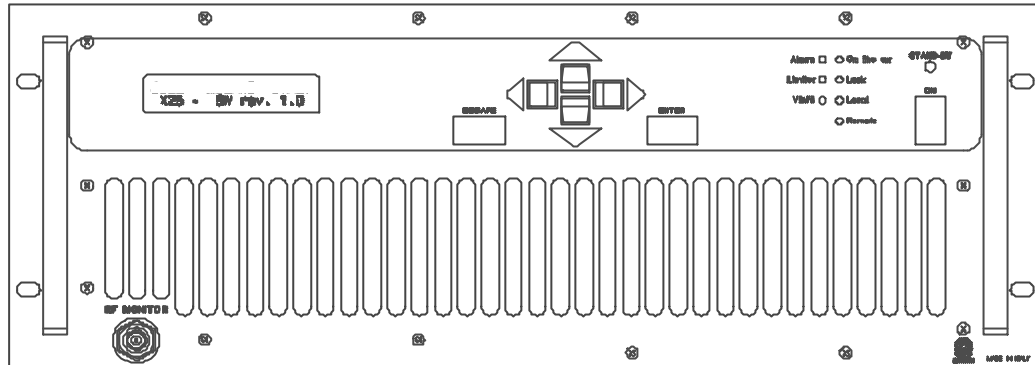

SOFRATEC BROADCAST EQUIPMENT

WWW.sofratec.com - e-mail : info@sofratec.com Tel: +33 4 93 01 99 99 Fax: +33 4 93 01 99 71

**EXB500 TRANSMITTER - REAR & BOTTOM INTERNAL VIEW**

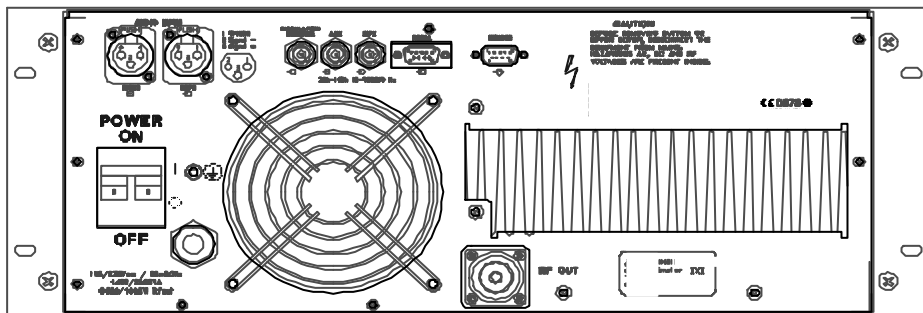
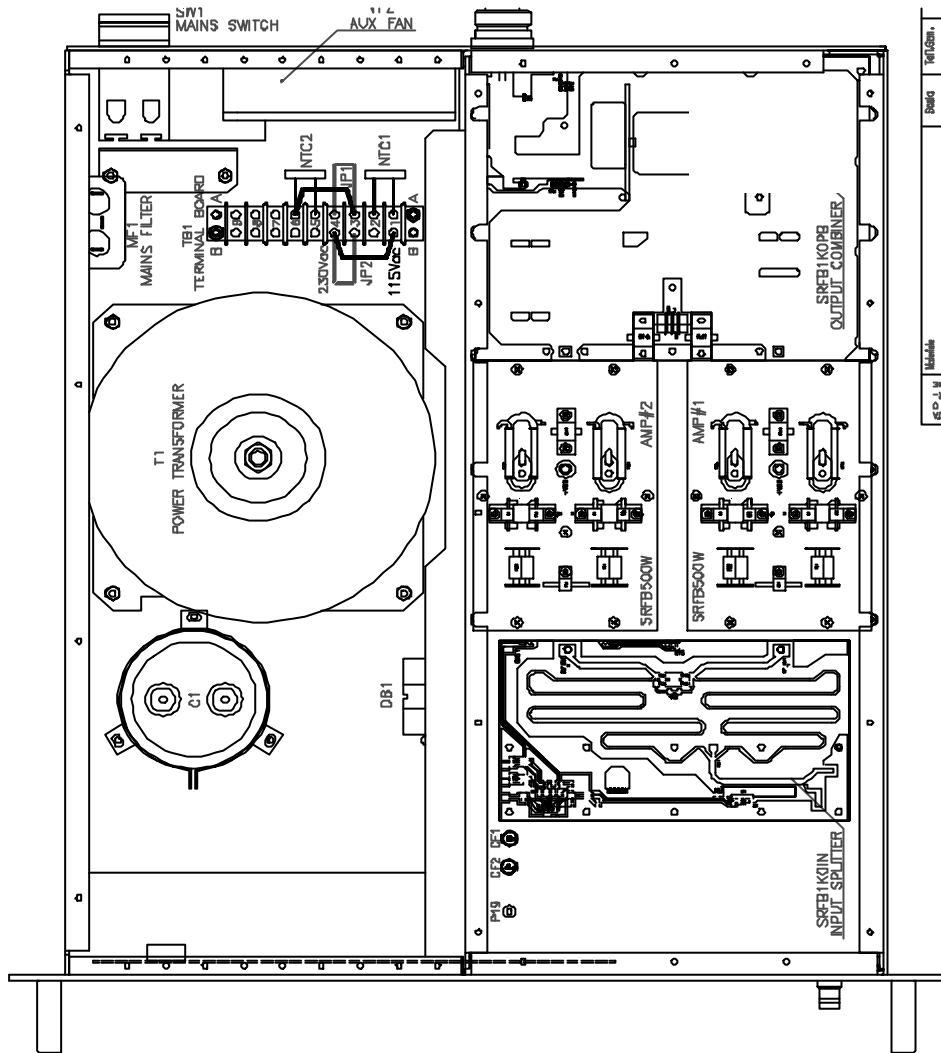

**EXB500 TRANSMITTER - GENERAL ELECTRICAL DIAGRAM**

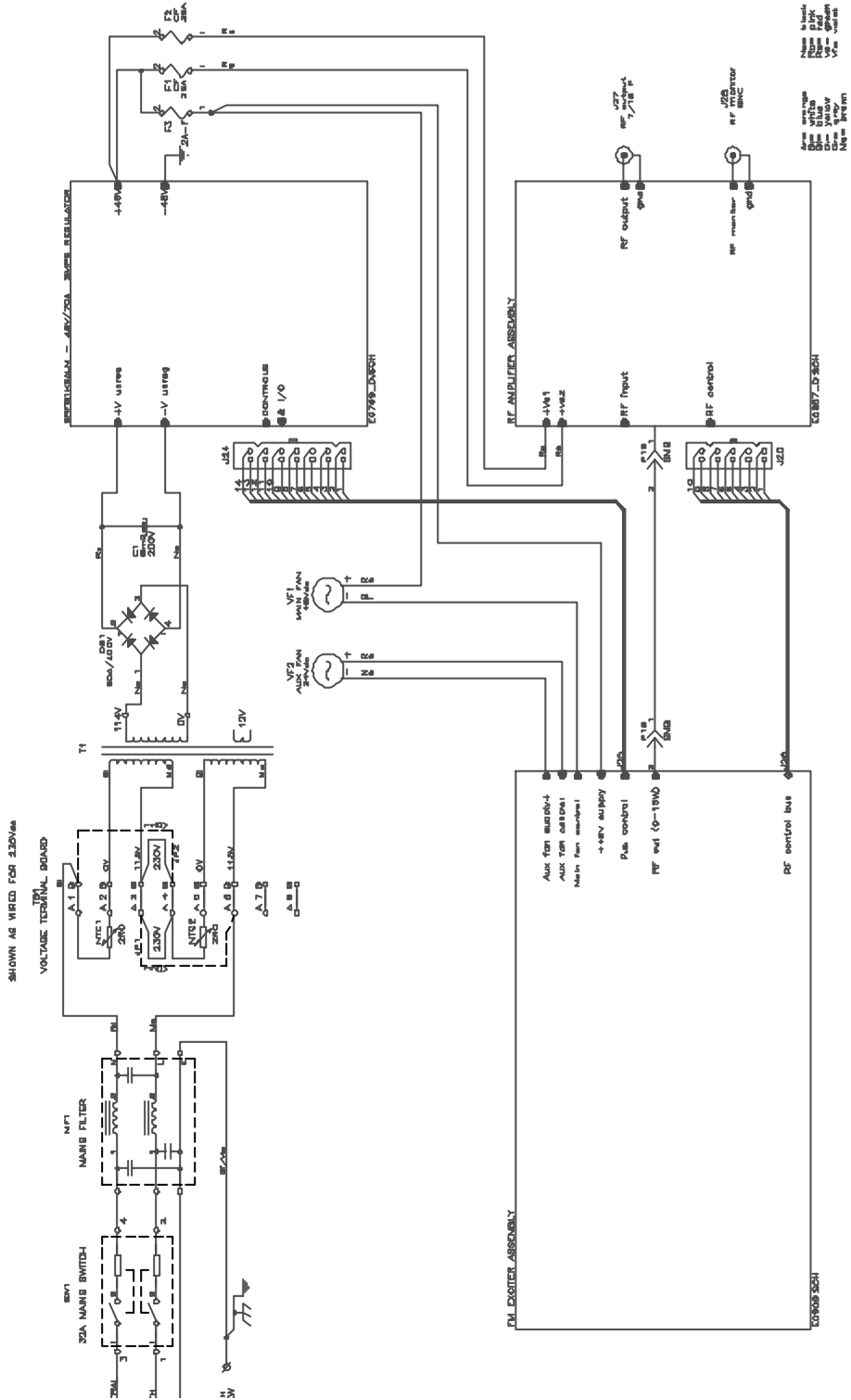

EXB500 TRANSMITTER - EXCITER ASSEMBLY ELECTRICAL DIAGRAM

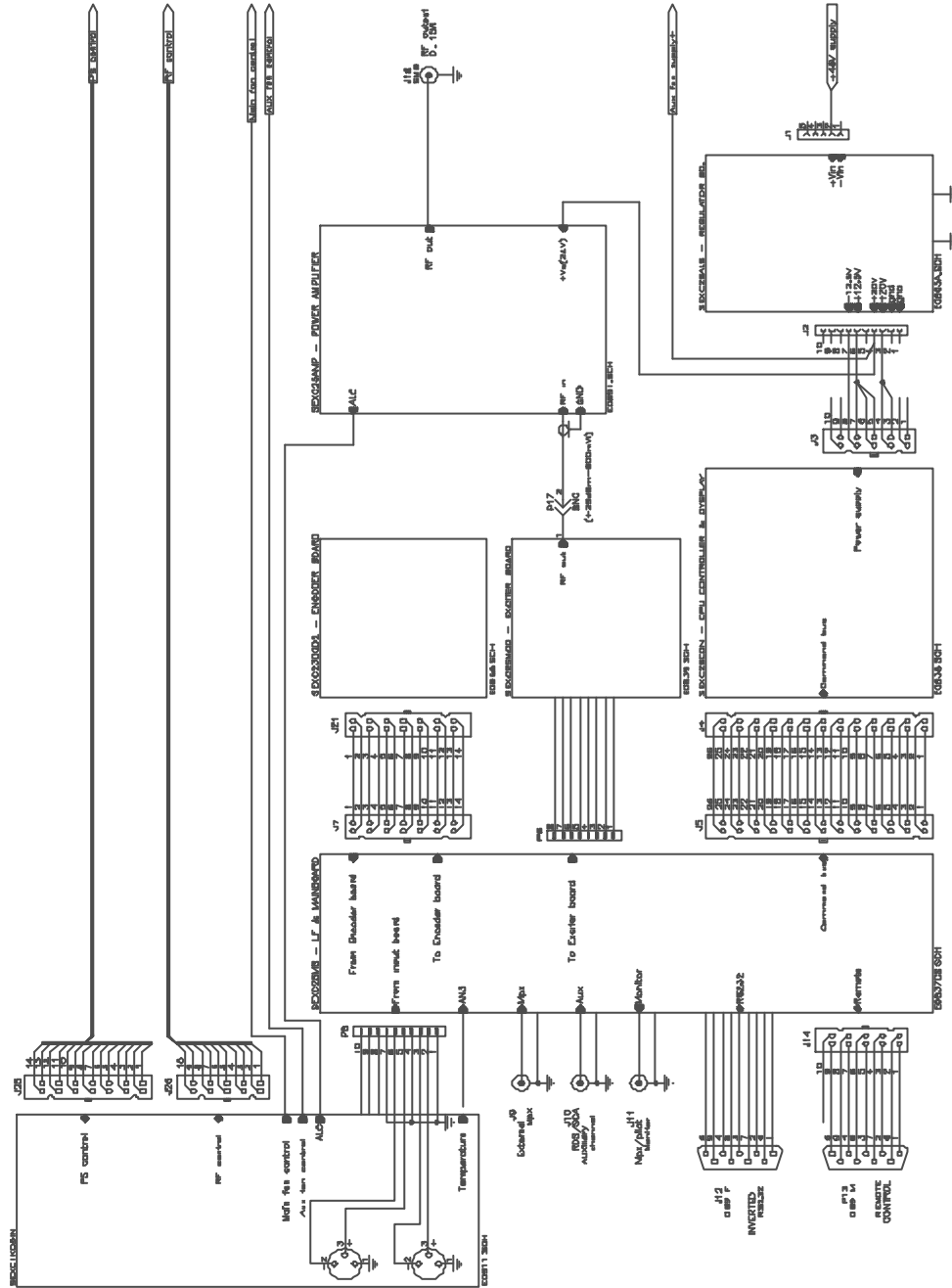

THE STEREO-ENCODER BOARD IS MOUNTED ONLY AS AN OPTION

**SEXC25A15 - AUXILIARY POWER REGULATOR BOARD**

**ELECTRICAL DIAGRAM**

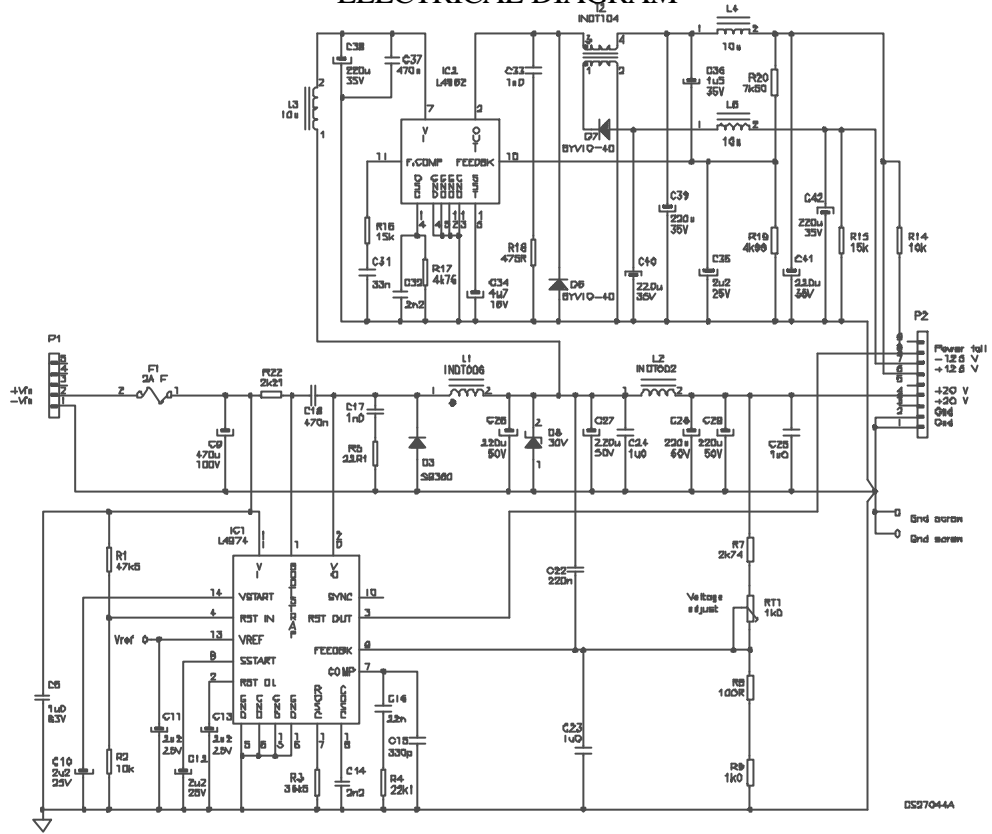

**TIPOGRAFIA DI COMPONENTI**

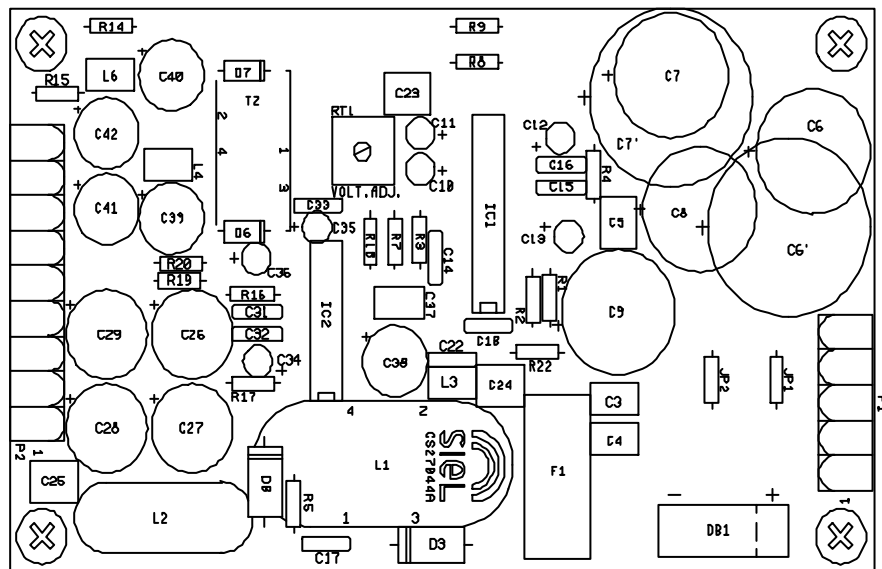

SOFRATEC BROADCAST EQUIPMENT

WWW.sofratec.com - e-mail : info@sofratec.com Tel: +33 4 93 01 99 99 Fax: +33 4 93 01 99 71

SEXC25CON - CPU CONTROLLER & DISPLAY BOARD ELECTRICAL DIAGRAM

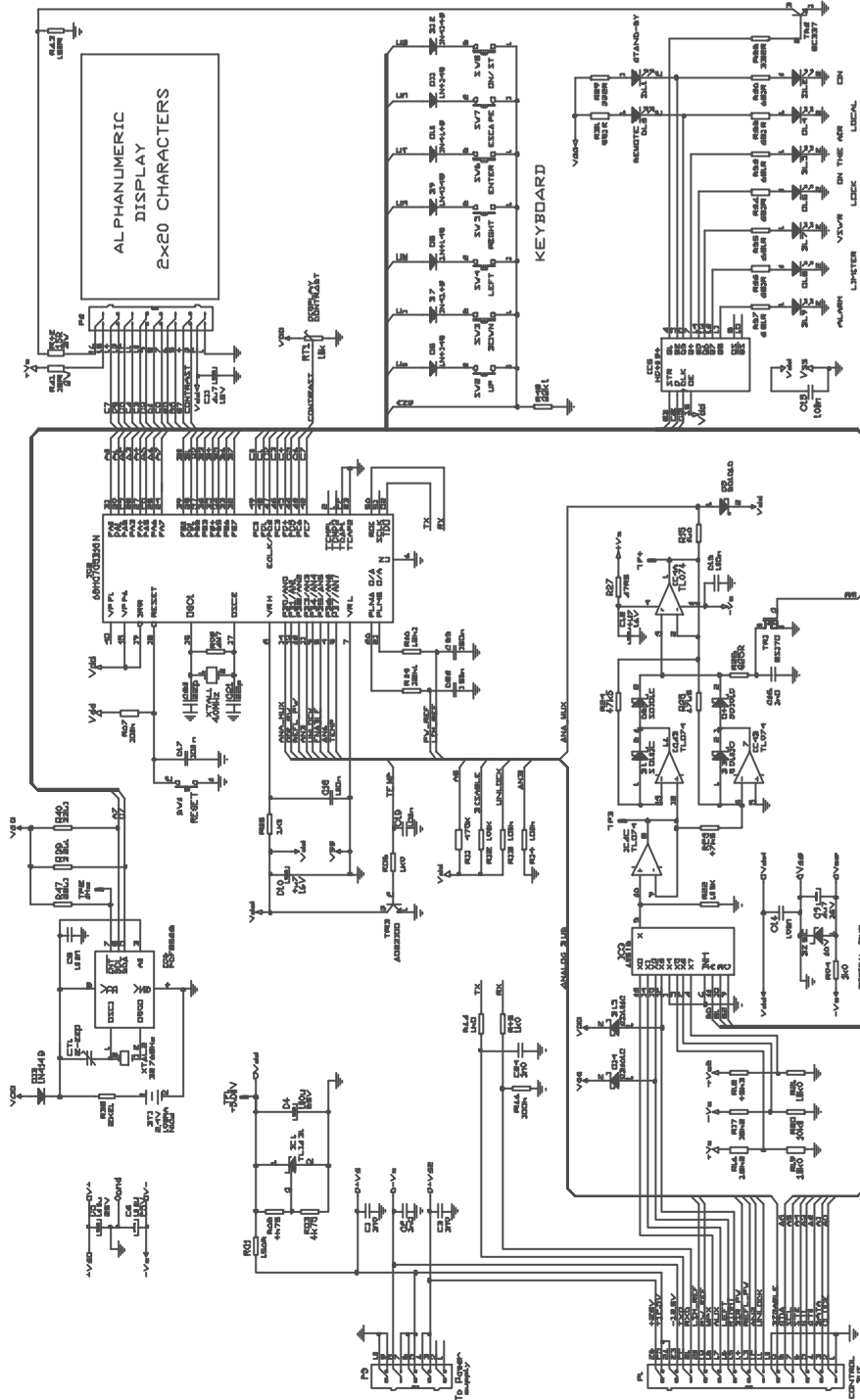

SOFRATEC BROADCAST EQUIPMENT

WWW.sofratec.com - e-mail : info@sofratec.com Tel: +33 4 93 01 99 99 Fax: +33 4 93 01 99 71



**SEXC25CON** - CPU CONTROLLER & DISPLAY BOARD  
COMPONENTS LAYOUT

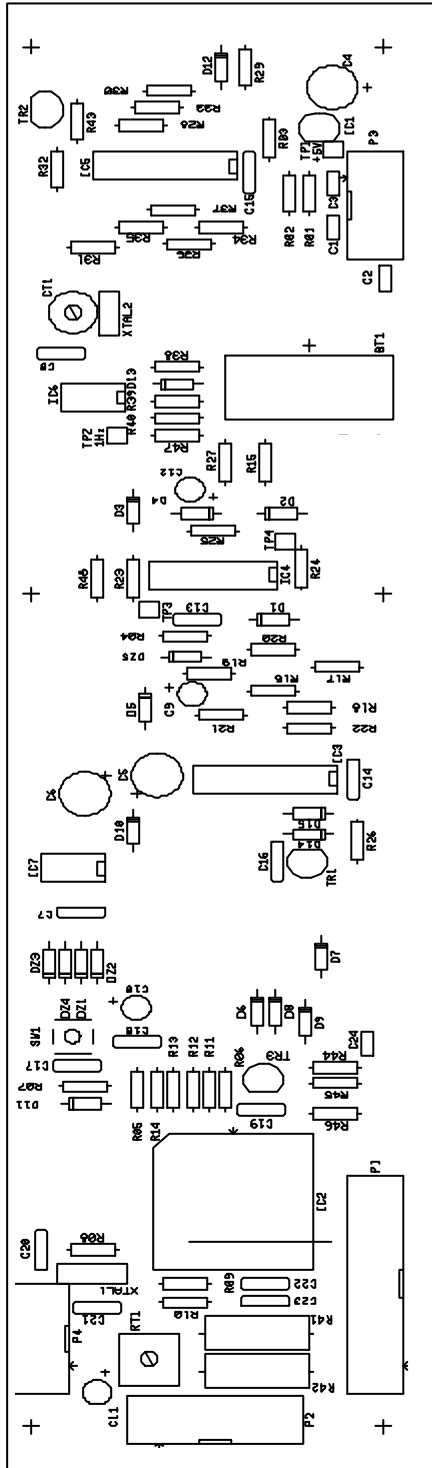

COMPONENT SIDE

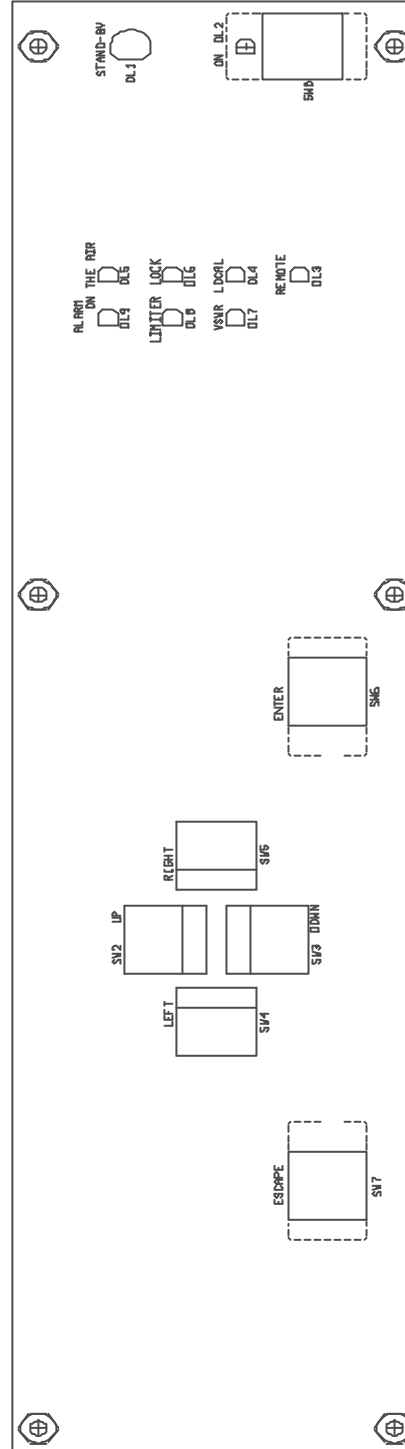

SOLDER SIDE

SOFRATEC BROADCAST EQUIPMENT

WWW.sofratec.com - e-mail : info@sofratec.com Tel: +33 4 93 01 99 99 Fax: +33 4 93 01 99 71

**SEXC1K05IN - INPUT & INTERFACE BOARD**

**ELECTRICAL DIAGRAM**

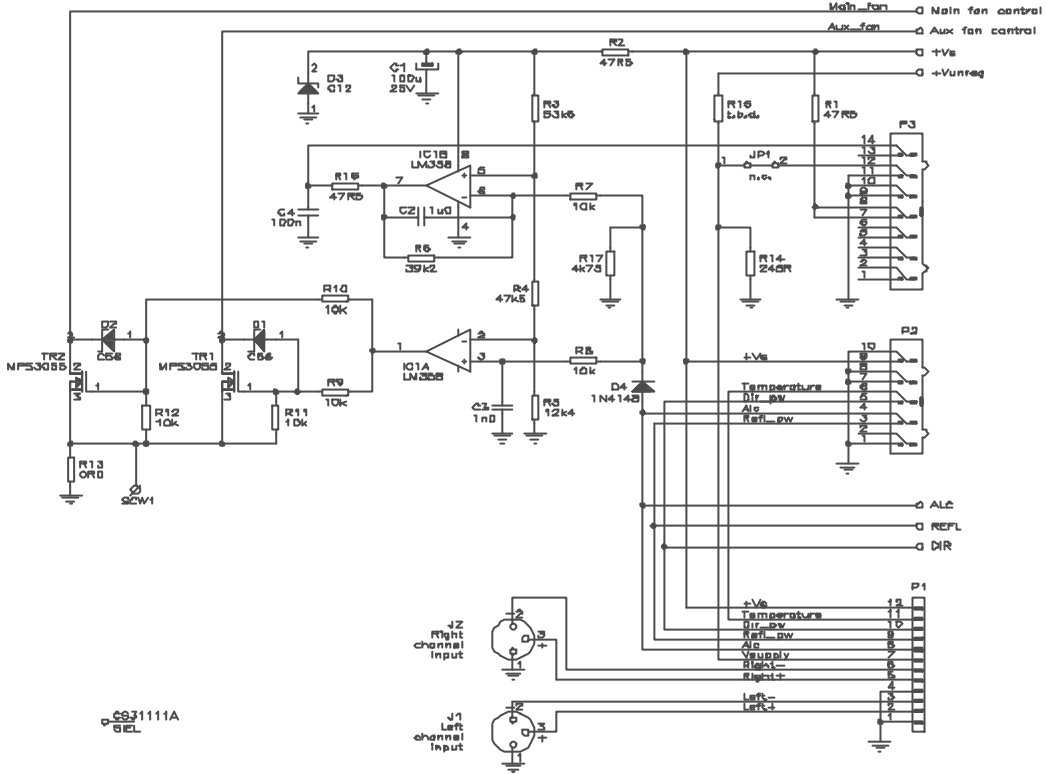

**TIPOGRAFIA DI COMPONENTI**

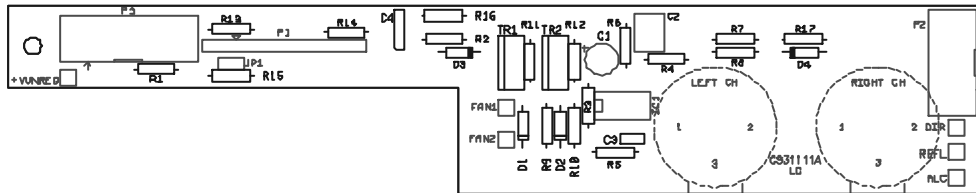

EXB500 - USER AND MAINTENANCE MANUAL - rev.1.0 - 03/02  
**SEXC25MB** - MAINBOARD / I/O & RF CONTROL SECTION  
 ELECTRICAL DIAGRAM - 1 of 2

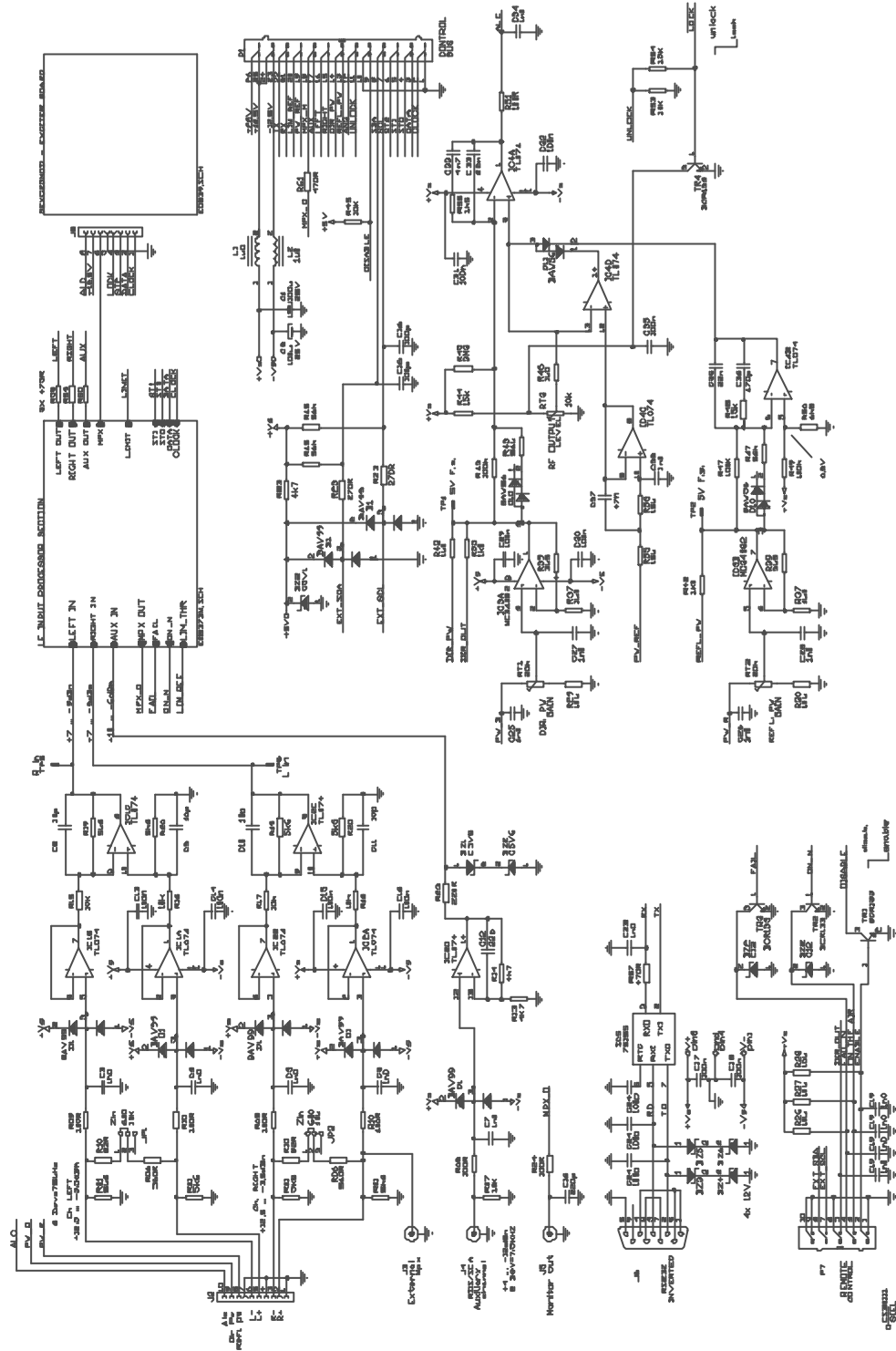

COMPONENTS MAY VARY DUE TO PRODUCTION ADJUSTMENTS

**SEXC25MB** - MAINBOARD / LF PROCESS SECTION  
ELECTRICAL DIAGRAM - 2 of 2

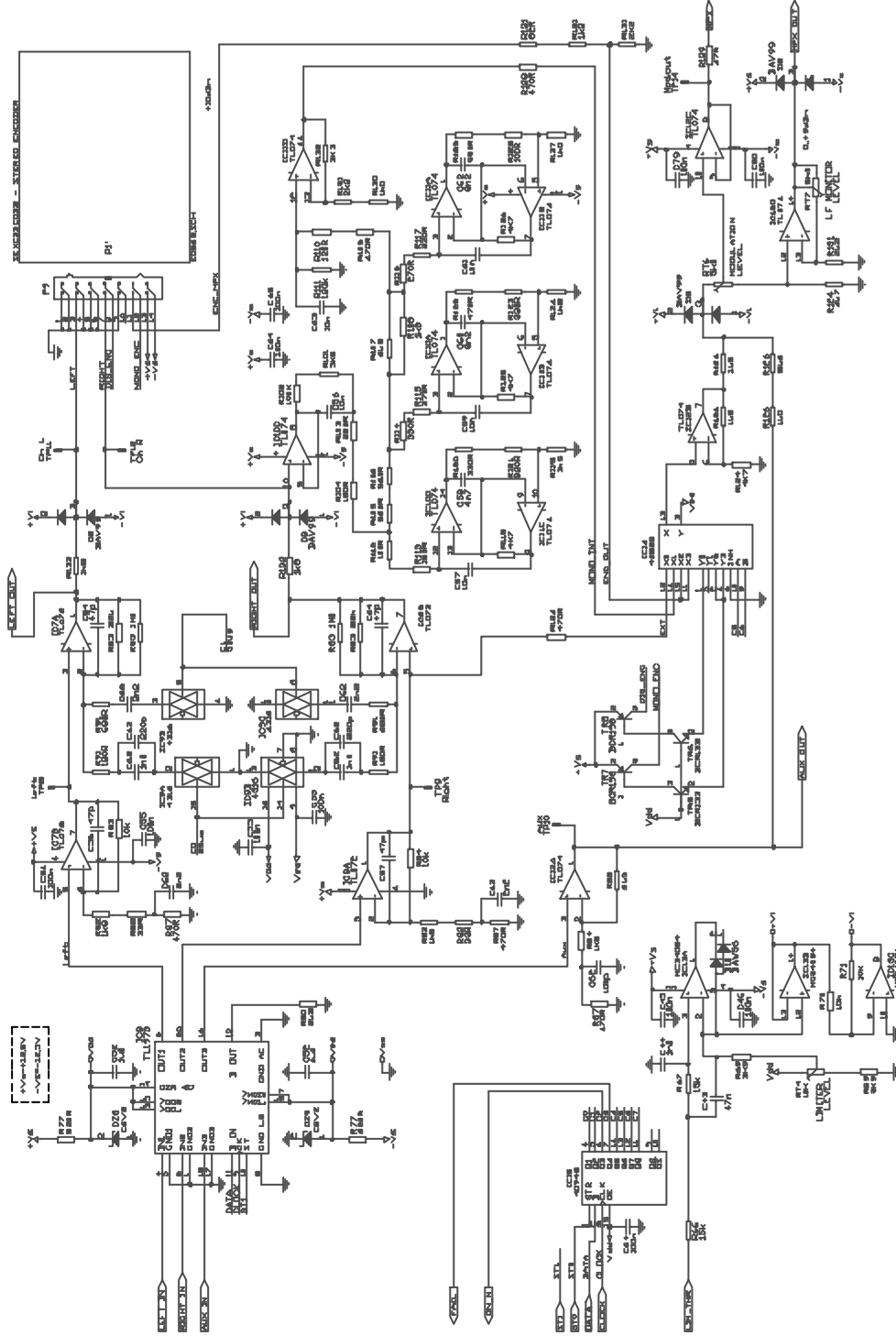

**SEXC25MB - MAINBOARD  
COMPONENT LAYOUT**

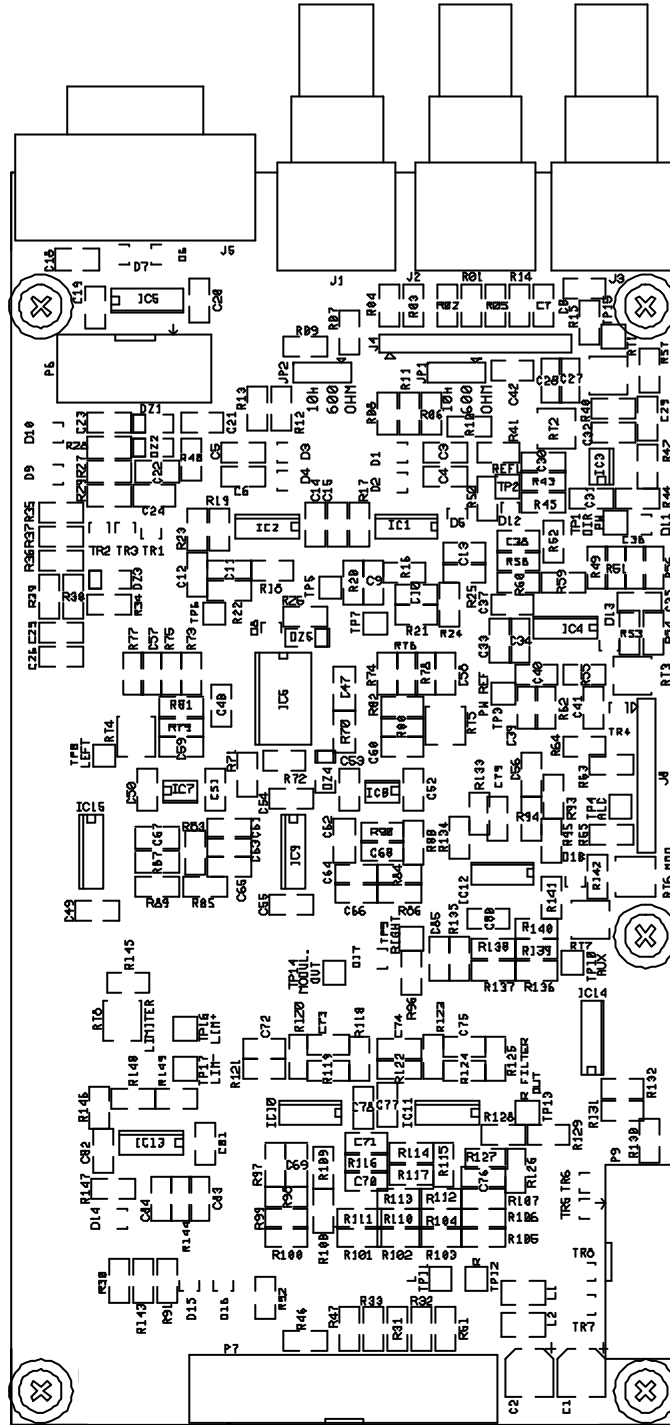

SOFRATEC BROADCAST EQUIPMENT

WWW.sofratec.com - e-mail : info@sofratec.com Tel: +33 4 93 01 99 99 Fax: +33 4 93 01 99 71

SEXC23COD2 - STEREO ENCODER BOARD - ELECTRICAL DIAGRAM

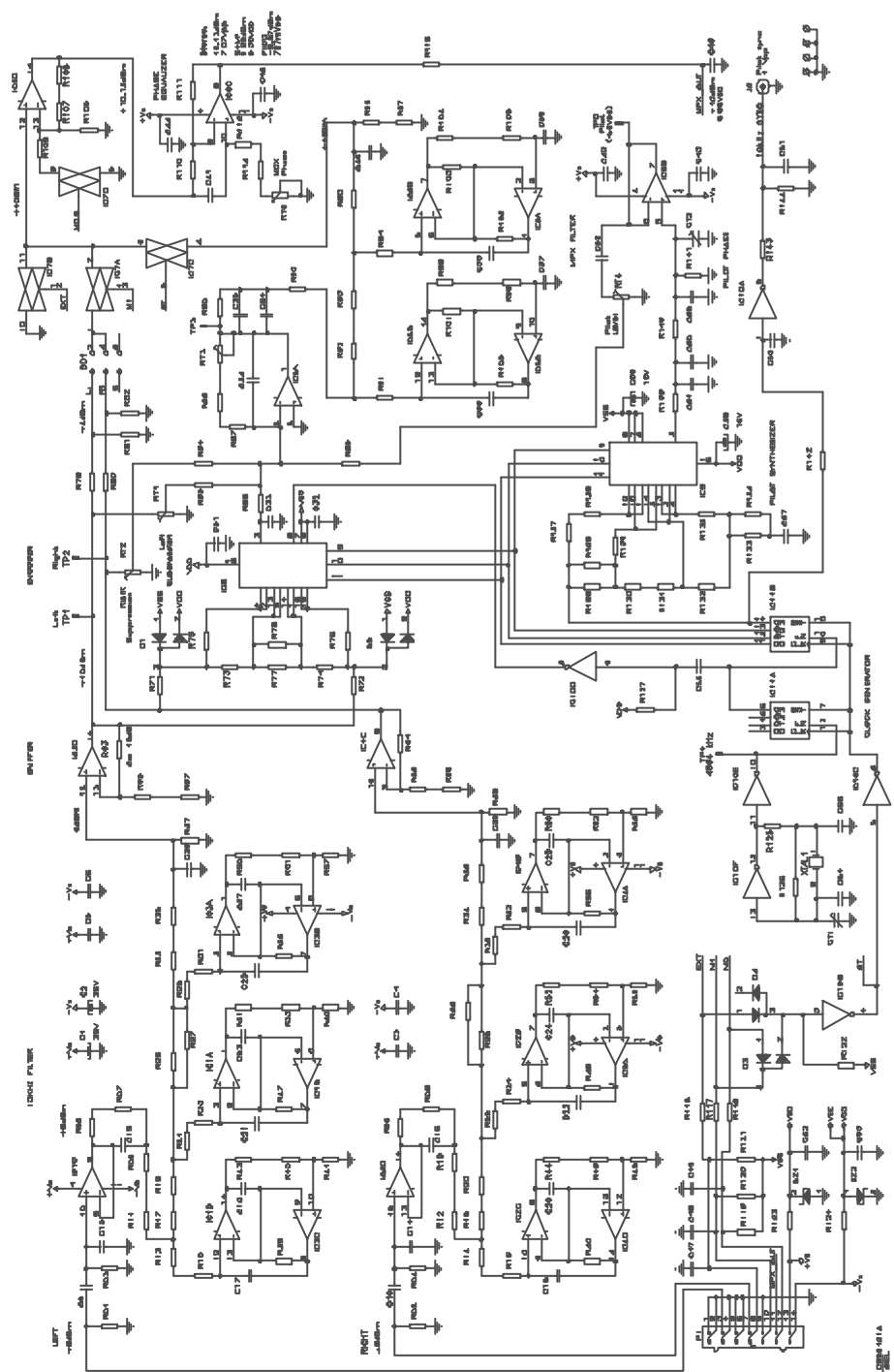

**SEXC23COD2 - STEREO ENCODER BOARD  
COMPONENT LAYOUT**



SOFRATEC BROADCAST EQUIPMENT

WWW.sofratec.com - e-mail : info@sofratec.com Tel: +33 4 93 01 99 99 Fax: +33 4 93 01 99 71

SEXC25MOD - FM EXCITER BOARD - ELECTRICAL DIAGRAM

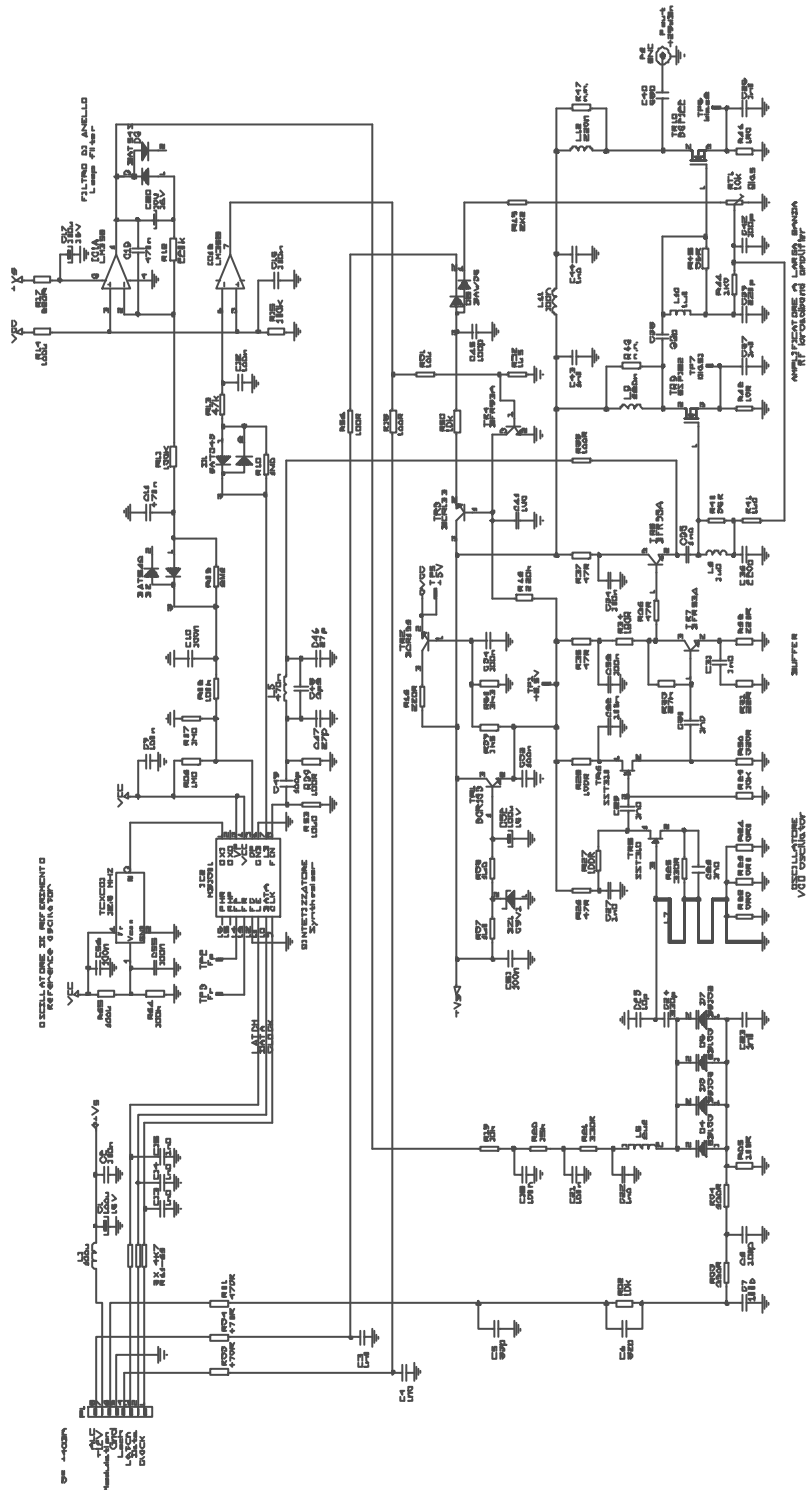

COMPONENTS MAY VARY DUE TO PRODUCTION ADJUSTMENTS



**SEXC25MOD - FM EXCITER BOARD - COMPONENT LAYOUT**

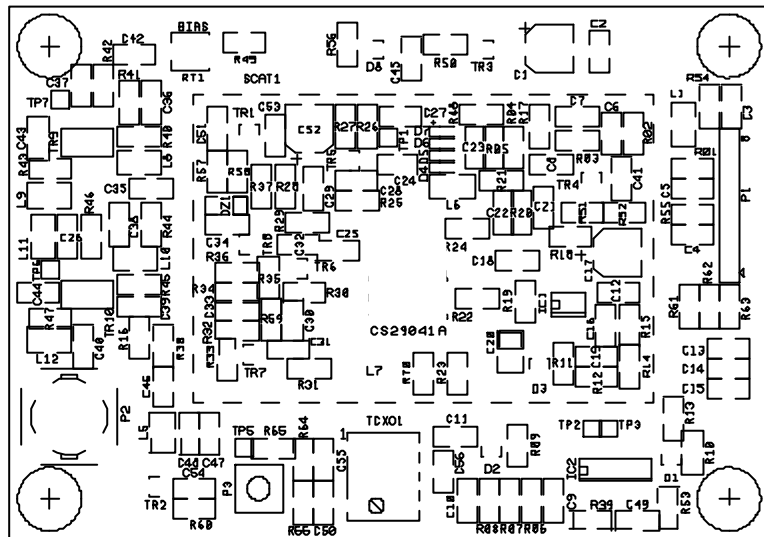

SOFRATEC BROADCAST EQUIPMENT

WWW.sofratec.com - e-mail : info@sofratec.com Tel: +33 4 93 01 99 99 Fax: +33 4 93 01 99 71

**ASEXC25AMP - FM 25W POWER AMPLIFIER**  
**ELECTRICAL DIAGRAM**

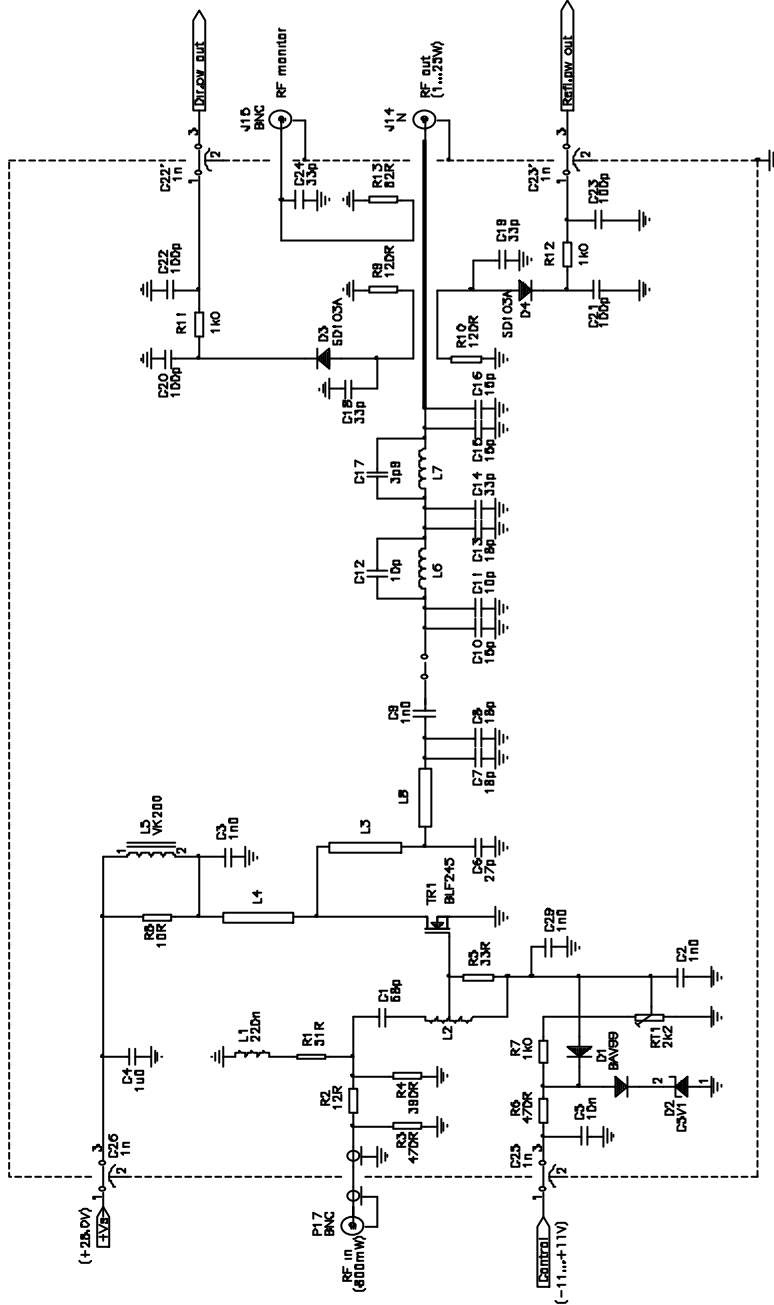

SOFRATEC BROADCAST EQUIPMENT

WWW.sofratec.com - e-mail : info@sofratec.com Tel: +33 4 93 01 99 99 Fax: +33 4 93 01 99 71

**ASEXC25AM5 - FM 25W POWER AMPLIFIER  
COMPONENT LAYOUT**

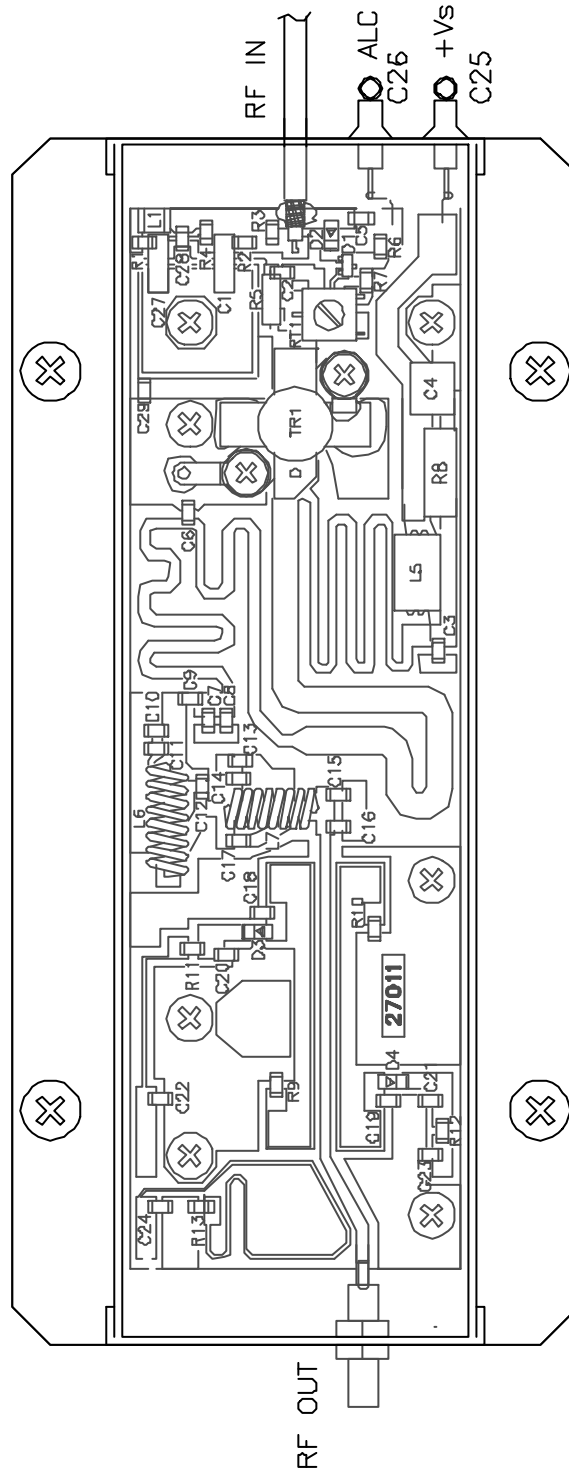

SOFRATEC BROADCAST EQUIPMENT

WWW.sofratec.com - e-mail : info@sofratec.com Tel: +33 4 93 01 99 99 Fax: +33 4 93 01 99 71

EXB500SM RF AMPLIFIER ASSEMBLY - ELECTRICAL DIAGRAM

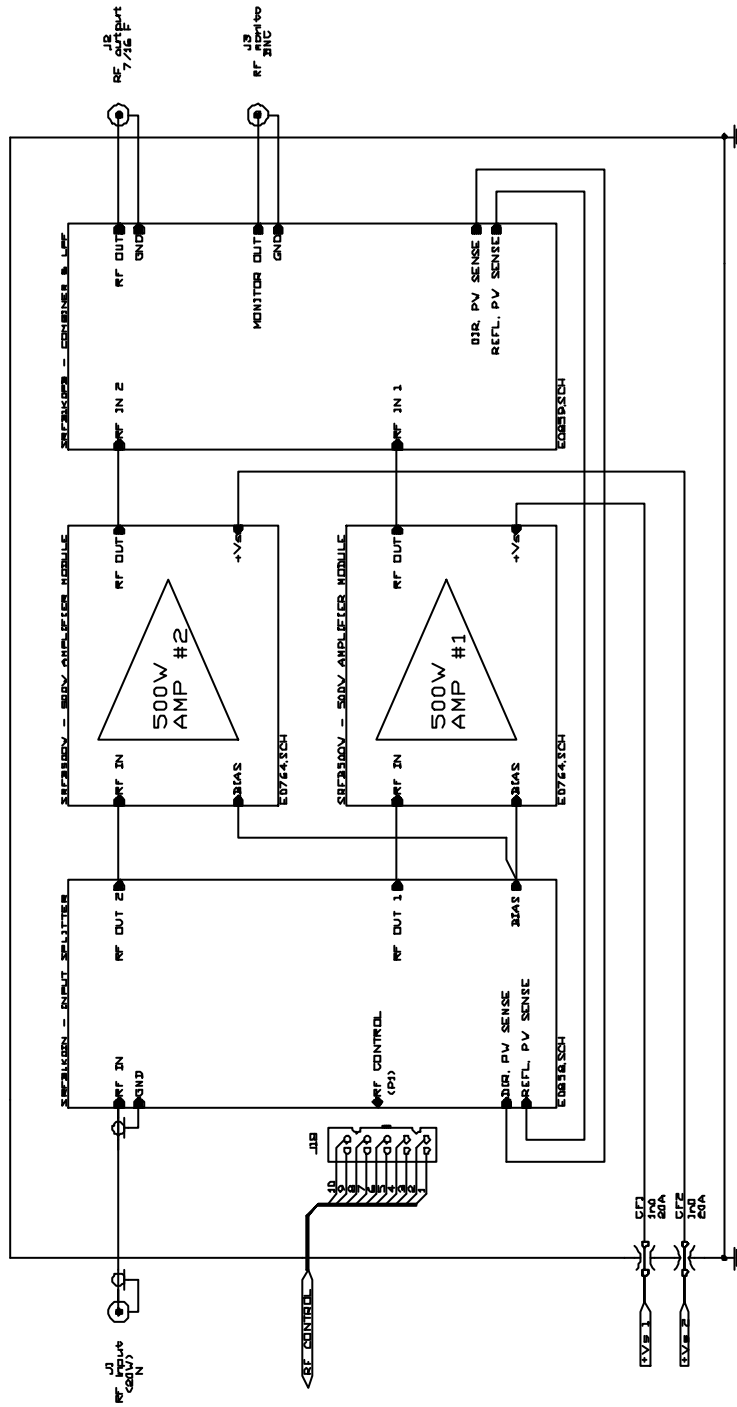

**SRFB1K0IN - 2-PORT RF INPUT SPLITTER  
ELECTRICAL DIAGRAM**

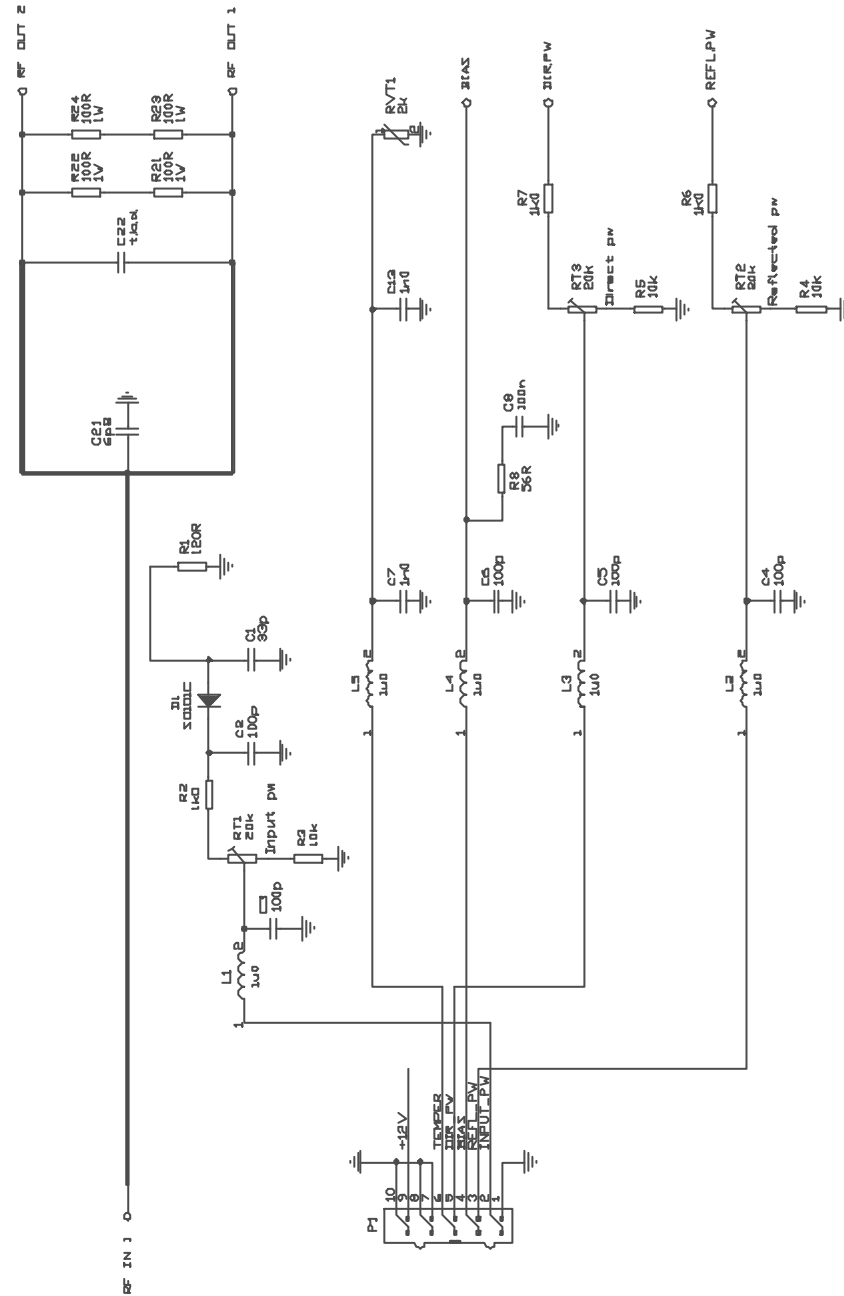

SOFRATEC BROADCAST EQUIPMENT

WWW.sofratec.com - e-mail : info@sofratec.com Tel: +33 4 93 01 99 99 Fax: +33 4 93 01 99 71

**SRFB1K0PB** - 2-PORT RF OUTPUT COMBINER & LPF  
ELECTRICAL DIAGRAM

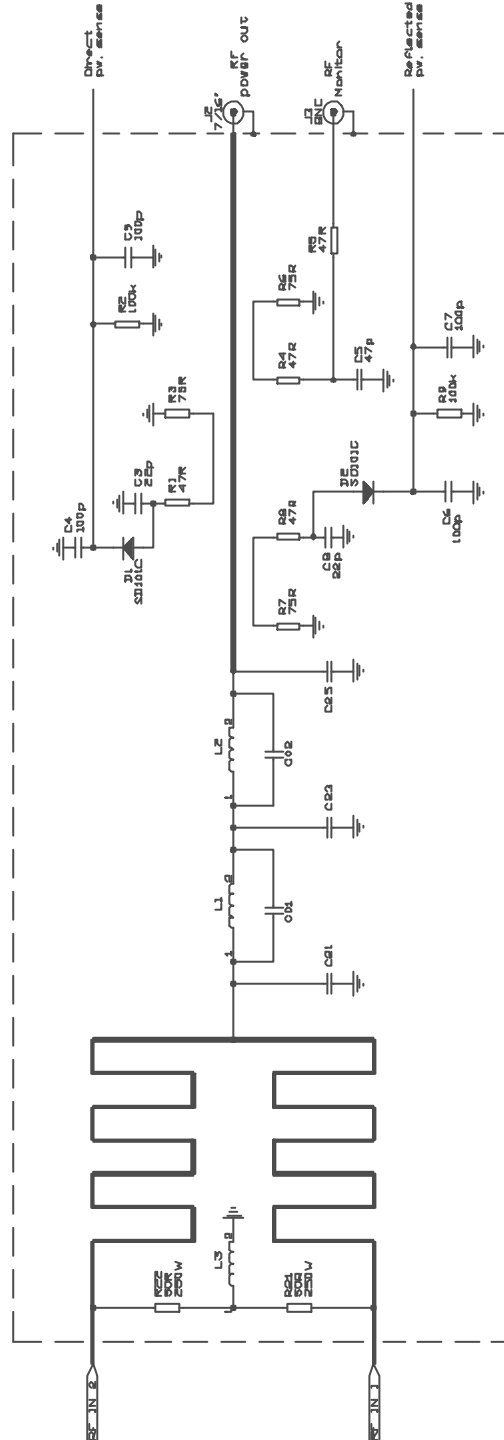

**SRFB500W - 500W AMPLIFIER MODULE**  
**ELECTRICAL DIAGRAM**

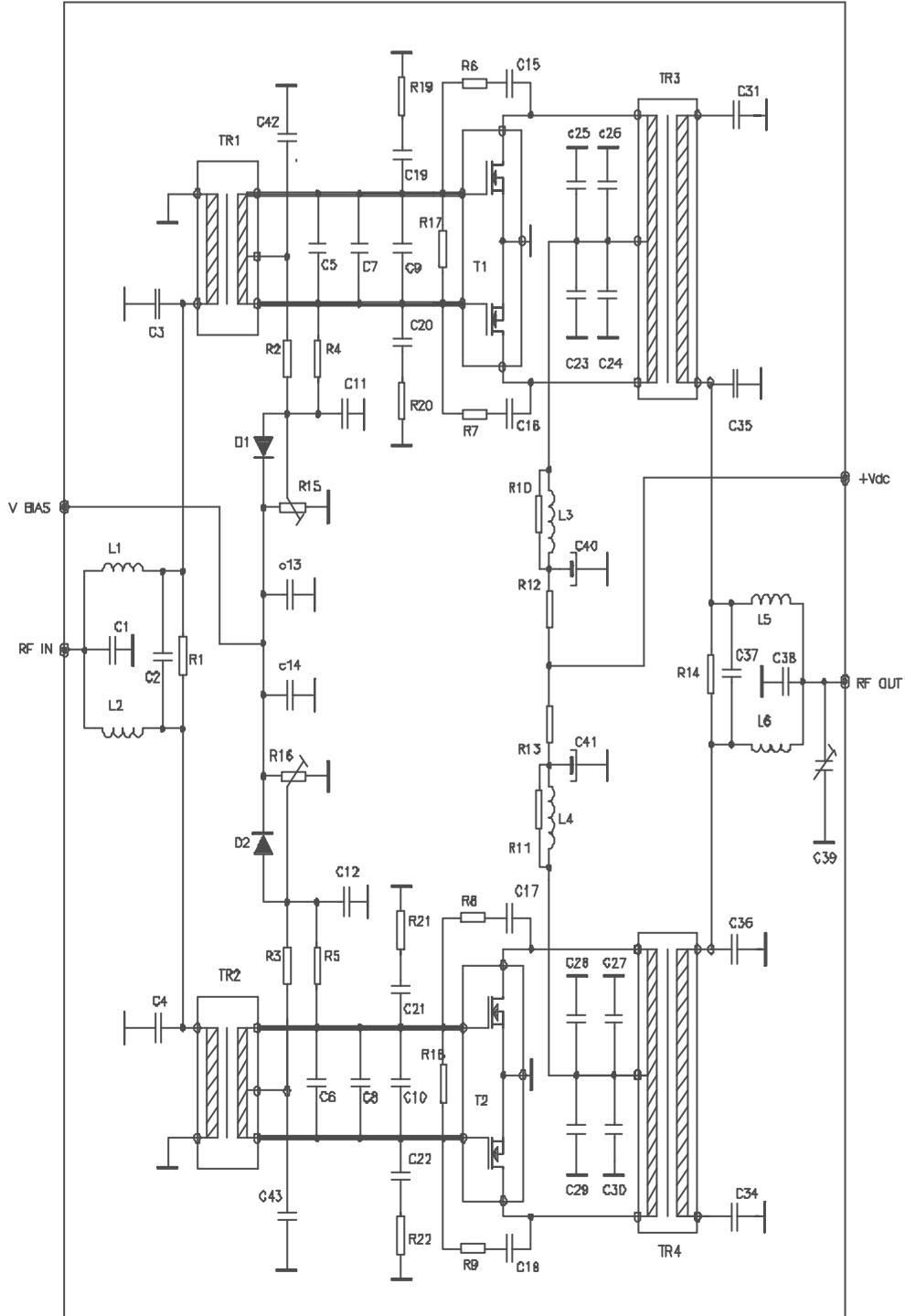

SOFRATEC BROADCAST EQUIPMENT

WWW.sofratec.com - e-mail : info@sofratec.com Tel: +33 4 93 01 99 99 Fax: +33 4 93 01 99 71

**SRFB500W - 500W AMPLIFIER MODULE  
COMPONENT LAYOUT**

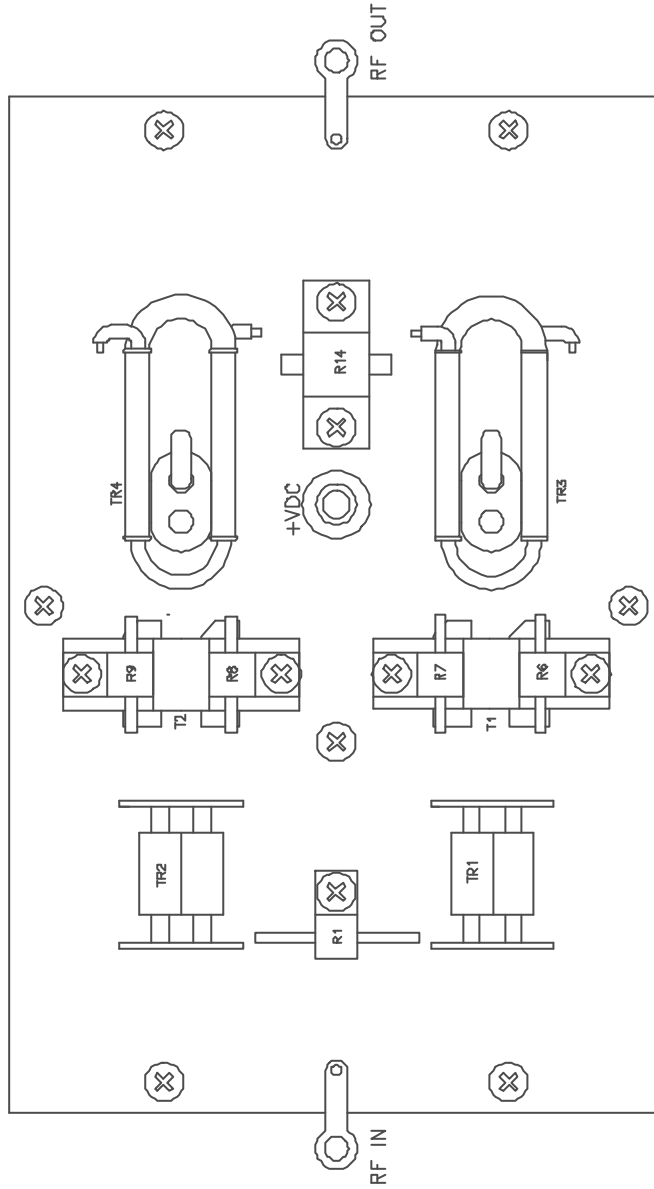



**SRFB1K5ALM** - 48V/70A SMPS REGULATOR  
ELECTRICAL DIAGRAM - POWER SECTION

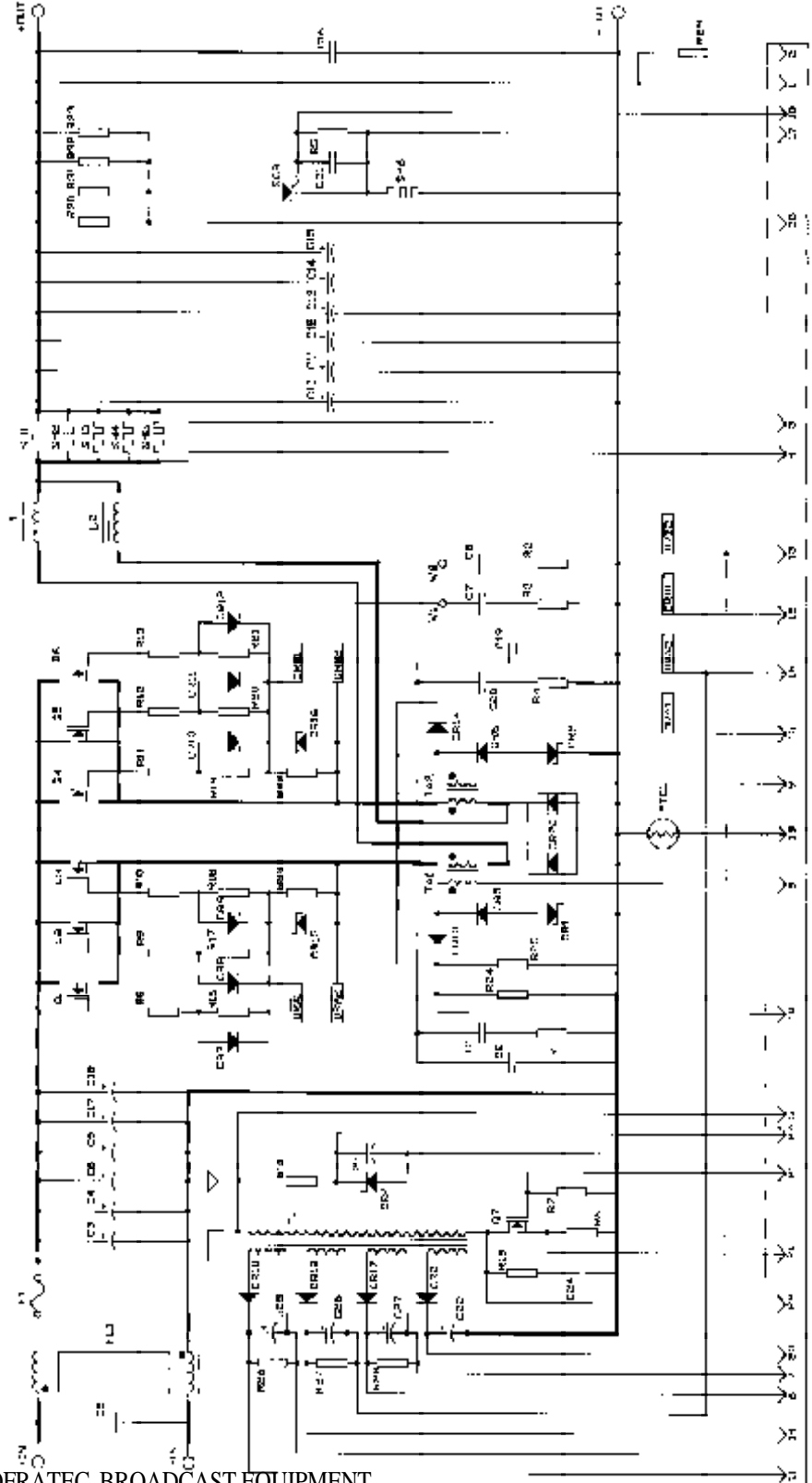

SOFRATEC BROADCAST EQUIPMENT

WWW.sofratec.com - e-mail : info@sofratec.com Tel: +33 4 93 01 99 99 Fax: +33 4 93 01 99 71

**SRFB1K5ALM - 48V/70A SMPS REGULATOR**  
**ELECTRICAL DIAGRAM - CONTROL SECTION**

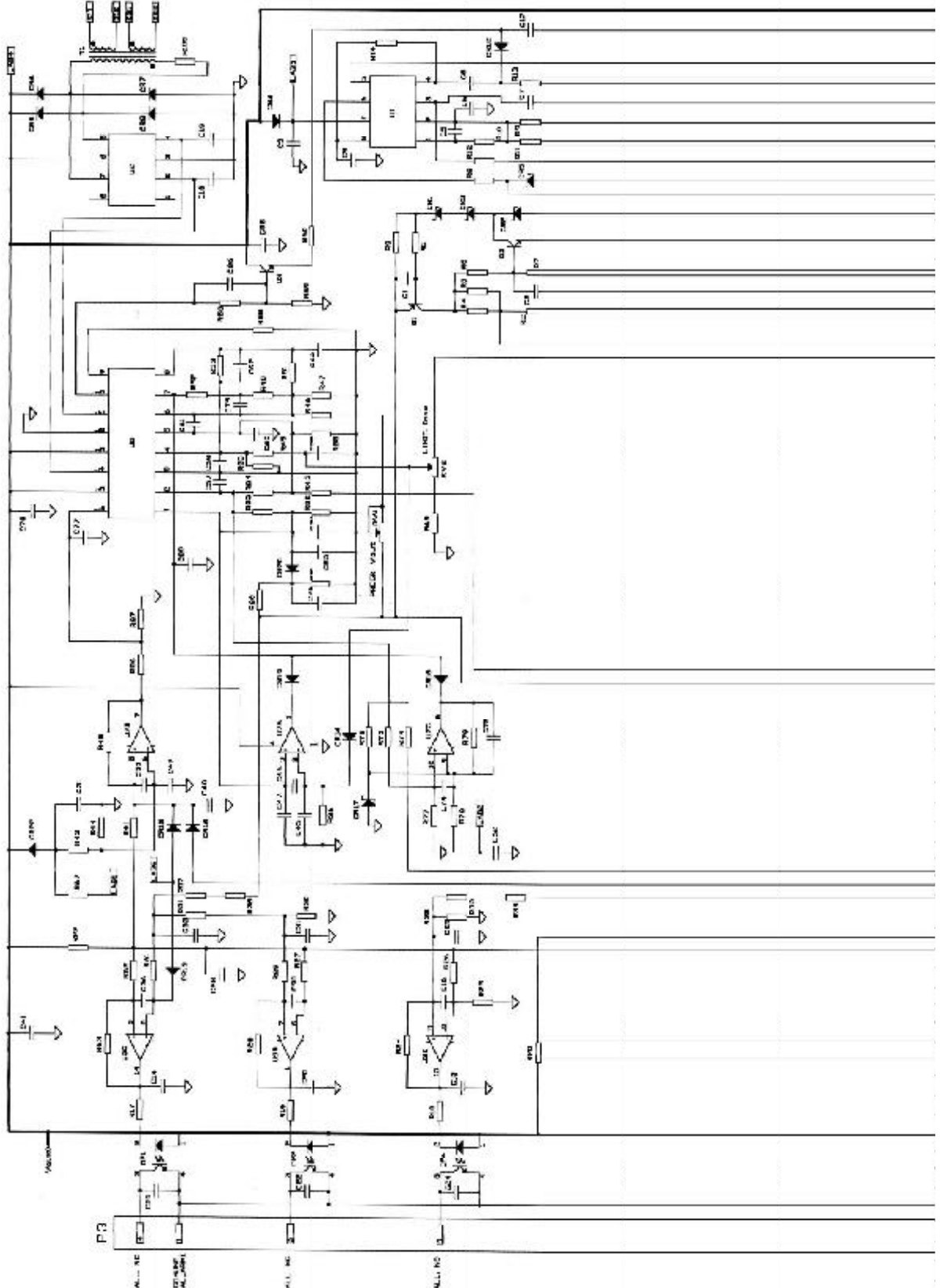

SOFRATEC PROTECTS YOUR INVESTMENT

WWW.sofratec.com - e-mail : info@sofratec.com Tel: +33 4 93 01 99 99 Fax: +33 4 93 01 99 71

**SRFB1K5ALM - 48V/70A SMPS REGULATOR**  
**COMPONENT LAYOUT - POWER SECTION**

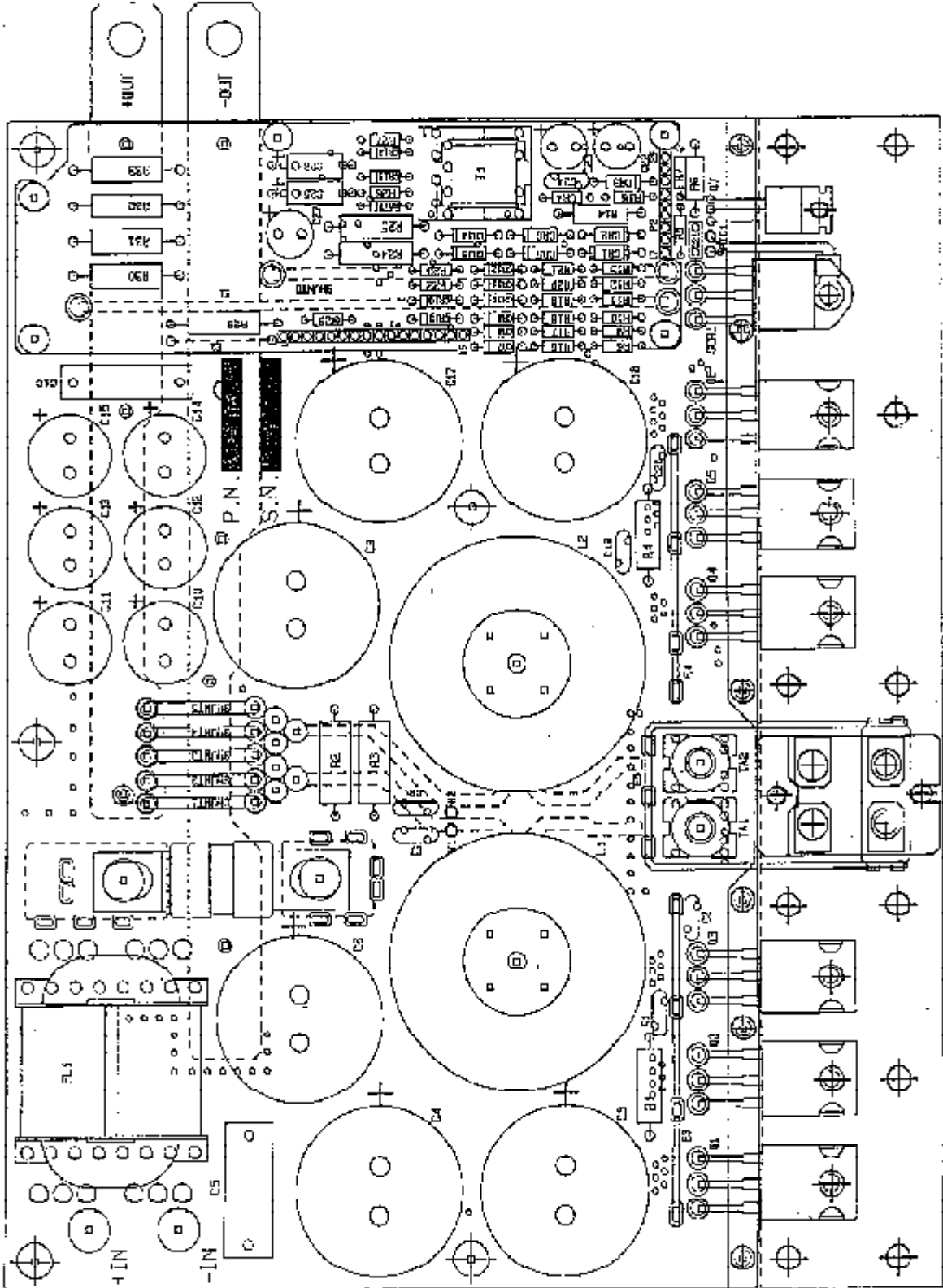

SOFRATEC BROADCAST EQUIPMENT

WWW.sofratec.com - e-mail : info@sofratec.com Tel: +33 4 93 01 99 99 Fax: +33 4 93 01 99 71

