



Via G. Amendola 9 - 44028 Poggio Renatico (FE) - Italy
Tel. +39 0532 829 965 - Fax +39 0532 829 177
E-Mail: info@elenos.com
Indirizzo Internet: www.elenos.com



ELC40
40W EXCITER

TECHNICAL MANUAL
Edition: April 1996
Cod: [MAN0066](#)



SOMMARIO

TECHNICAL CHARACTERISTICS.....	4
FRONT PANEL	8
REAR PANEL (OPTION MF-LM-SR).....	9
REAR PANEL (OPTION MX).....	11
BLOCK DIAGRAM (OPTION MF-LM-ST).....	12
BLOCK DIAGRAM (OPTION MX).....	13
AC LINE.....	14
USER INSTRUCTIONS.....	15
MODULE DESCRIPTION	
DC POWER SUPPLY	ALSW40..... 17
MPX INPUT BOARD	BFI..... 17
INPUT BOARD WITH FILTERS	EL08/1-2..... 17
LIMITER	SLIM..... 18
STEREOGENERATOR	EL09..... 18
MODULATOR.....	FMO..... 19
R.F. AMPLIFIER.....	40W-FBP40-DC40..... 19
MULTIMETER	MTA..... 19
POWER and FREQUENCY SETTING.....	SRT..... 19
CABLE.....	21
SCHEMATICS	
A.C. PLUG-IN	23
PARTS LIST	24
INPUT BOARDS ELECTRIC DIAGRAM.....	EL08/1-2..... 25
LAYOUT	EL08/1-2..... 28
PARTS LIST	EL08/1-2..... 31
LIMITER ELECTRIC DIAGRAM.....	LIM..... 34
LAYOUT	LIM..... 35
PARTS LIST	LIM..... 36
STEREOCODER ELECTRIC DIAGRAM.....	EL09..... 37
LAYOUT	EL09..... 39
PARTS LIST	EL09..... 40
MODULATOR ELECTRIC DIAGRAM.....	FMO..... 42
LAYOUT	FMO..... 44
PARTS LIST	FMO..... 45
MULTIMETER ELECTRIC DIAGRAM.....	MTA..... 47
LAYOUT	MTA..... 48
PARTS LIST	MTA..... 49
FQ/PW SETTING ELECTRIC DIAGRAM.....	SRT..... 50
LAYOUT	SRT..... 52
PARTS LIST	SRT..... 53
R.F.AMPLIFIER ELECTRIC DIAGRAM	40W..... 55
LAYOUT	40W..... 56
PARTS LIST	40W..... 57
LOW-PASS FILTER ELECTRIC DIAGRAM.....	FPB40..... 58
LAYOUT	FPB40..... 59
PARTS LIST	FPB40..... 60

DIR. COUPLER ELECTRIC DIAGRAM.....	DC40	61
LAYOUT	DC40	62
PARTS LIST	DC40	63
POWER SUPPLY ELECTRIC DIAGRAM	ALSW40.....	64
LAYOUT	ALSW40.....	65
PARTS LIST	ALSW40.....	66
TEMP. CONTROL ELECTRIC DIAGRAM	TMP.....	67
LAYOUT	TMP.....	68
PARTS LIST	TMP.....	69
P RESET ELECTRIC DIAGRAM.....	RESET.....	70
LAYOUT	RESET.....	71
PARTS LIST	RESET.....	72
MPX INPUT ELECTRIC DIAGRAM	BFI.....	73
LAYOUT	BFI.....	74
PARTS LIST	BFI.....	75
COLLEGAMENTI CANNON “XLR”		76

CABLAGGI

FRONT WIEV WIRING DIAGRAM	MF-LM-ST OPTION	77
FRONT WIEV WIRING DIAGRAM	MX OPTION.....	78
REAR WIEV WIRING DIAGRAM.....	MF-LM-ST OPTION	79
REAR WIEV WIRING DIAGRAM.....	MX OPTION.....	80

ATTACHMENTS:

PROCEDURES OF THE HPT40 ADJUSTMENTS	81
PROCEDURES OF THE HPT40 TEST.....	87

SYSTEM CHARACTERISTICS

RF SECTION

FREQUENCY RANGE	FM 87.5÷108 MHz band. Frequency carrier presettable only from 87.6 to 107.9MHz on the front panel in 100KHz increments, with an internal fine frequency adjustments. Other bands from 50MHz up to 108MHz and 10KHz steps available.
MAX. POWER OUTPUT	2 to 40W with 2W step, presettable on the front panel.(max. power continuously variable)
TYPE	Solid state, direct FM frequency synthesized, crystal referenced, thermal compensated.
RF POWER	output connector: type N female, 50 impedance : 50 power stability : better than 1dB
FREQUENCY STABILITY	Better than 5 ppm, 0 °C to 40 °C
MODULATION TYPE	F3, direct FM at the carrier frequency.
ASYNCHRONOUS (no AM S/N RATIO)	60dB below reference carrier with 100% AM modulation, 50 s de-emphasis (FM modulation present).
SYNCHRONOUS AM S/N RATIO	60dB below reference carrier with 100% AM modulation (FM modulation ±75KHz).
HARM. or SUB-HARM. EMISSION	70 dBc or more below carrier level
SPURIOUS ANTENNA EMISSION	<-85dBc.
CARRIER SPURIOUS TX EMISSION (no antenna output measured)	<-70dB (in accordance with Decr. 311 art. 16)
TX SPURIOUS EMISSION (no antenna output measured)	<-90dB (in accordance with Decr. 311 art. 16)

MODULATION SECTION

MOD. CAPABILITY

Option MX	One Composite program (balanced or unbalanced input) and 3 subcarrier channels (SCA) up to 100KHz.
Option MF	One Mono (balanced or un-balanced input), one Composite program and 3 subcarrier channels (SCA) up to 200KHz.
Option ST	One Mono or Stereo (L and R channel, balanced or unbalanced input) or Composite program and 3 subcarrier channels (SCA) up to 200KHz.

MOD. INPUTS

SCA	10k impedance, frequency range 20KHz÷200KHz. All levels are factory set for +6dBm and adjustable in the 0÷12dBm range. Input connector: BNC.
Ext. MPX	10K impedance, frequency range 20Hz÷100KHz. The level is factory set for +6dBm and is adjustable in the 0 to +12dBm range. Input connector: BNC.
Left /Right Channel	Input impedance selectable 600 or 10K , frequency range 20÷15000Hz. Input level is factory set for +6dBm (different levels on request) and is adjustable in the 0÷+12dBm range. Input connector: balance Canon XLR, unbalanced BNC.

COMPOSITE FMS/N RATIO

(referred to ±75KHz dev and with 50 S de.emph)

Mono	80 dB, 85dB typical (with a 30÷20000Hz filter bandwidth).
Int. Stereo	80dB (L-R, decoded and with a 30Hz÷20000 filter bandwidth).
Ext. Stereo (MPX)	80dB (L-R, decoded and with a 30÷20000Hz filter bandwidth).

TOTAL HARM. DISTORTION

F=±75KHz and with 50 s de.emph.)

Mono	<0.03% - 0.02% typical
Int. Stereo (L/R Ch)	<0.04% - 0.02% typical (L-R, decoded and with a 30Hz÷20000 filter bandwidth).
Ext. Stereo (MPX)	<0.04% - 0.02% typical (L-R, decoded and with a 30Hz÷20000 filter bandwidth).

STEREO SEPARATION

Baseb. monitor out	Greater than 65dB 100Hz to 15KHz
	Greater than 60dB 40Hz to 15KHz.
TX	Greater than 50dB 40Hz to 15KHz

COMPOSITE AMPLITUDE RESPONSE

Mono	±0.15 dB - typ. 0.12dB [30Hz÷15KHz] <-45dB at 19KHz (typ. 55dB).
Int. Stereo (L/R Ch)	±0.15 dB - typ. 0.12dB [30Hz÷15KHz] <-45dB at 19KHz (typ. 55dB).
Ext. Stereo (MPX)	<±0.1 dB [30Hz÷15KHz].
SCA 1, 2, 3	<±1 dB [20KHz÷200KHz].

COMPOSITE

PHASE RESPONSE ±0.5 from linear phase [30Hz÷53KHz]

PRE-EMPHASIS VALUE 75 s for FCC or 50 s for CCIR (factory set).

PRE-EMPHASIS ERROR <±0.1dB.

FACILITIES

MULTIMETER	4 function diagnostic aid: peak and semipeak modulation, forward and reflected power
MONITORING	
Leds	-12 +5 +12 +24 Vdc. Transmitter PLL lock. Pre-emphasys presence. (option MF or ST) Internal coder "ON" (option ST). Overmodulation. (option MF or ST)
BNC connector	Carrier enable input, active grounded. 19KHz output, to synchronize external devices (i.e. RDS). (option ST) Sync. input for an external 2.5KHz clock TTL compatible, to synchronize PLL oscillator (for FM syncro).
SETTING	Output frequency 87.6÷107.9MHz, step 100KHz. (Other frequency range and 10KHz step on request.) Max. Forward power continuously variable. Forward power 2÷36W 2W step Refelected power continuously variable 1÷10W. Baseband VCO input -6 ÷ +5dBr 1dB step

GENERAL CHARACTERISTICS

ENVIRONMENTAL CONDITIONS

Temperature	Operating: 0 °C ÷ +40 °C Non-operating: -20 °C ÷ +50 °C
Humidity	Operating: up to 95% relative humidity (non-condensing) at +40 °C Non-operating: up to 90% relative humidity at +65 °C
Altitude	Operating: up to 4600 meters Non-operating: up to 15000 meters

POWER REQUIREMENTS

Voltage	100/120/220/240 Vac -% to +% 50-66Hz
Power	160VA maximum

WEIGHT

Net	approximately 16 kg.
Shipping	approximately 18 kg.

DIMENSION

Cabinet size	48.26 cm wide x 13.33 cm high x 48.26 cm deep.
Boxed	60 cm wide x 21 cm high x 59 cm deep

REQUIREMENTS

ELCA HPT SISTEM meet or exceed all CCR, ETSI and FCC requirements and particularly:

IT. D.M. n 311 dated 09/03/94	Italian requirements to ratify Radio broadcasting transmitters (frequency or amplitude modulated) and TV transmitters.
ETS - 300 -384	Radio broadcasting system; VHF, frequency modulated, sound broadcasting transmitter
CCIR - 450	Transmission standards for FM sound broadcasting at VHF
CCIR - 412	Planning standards for FM sound broadcasting at VHF
CCIR - 559	Objective measurement for radio frequency protection ratios in LF, MF and FH broadcasting
CCIR - 468	Measurement of audio frequency noise voltage levels in sound broadcasting.

CONTROLS and INDICATORS

FRONT PANEL

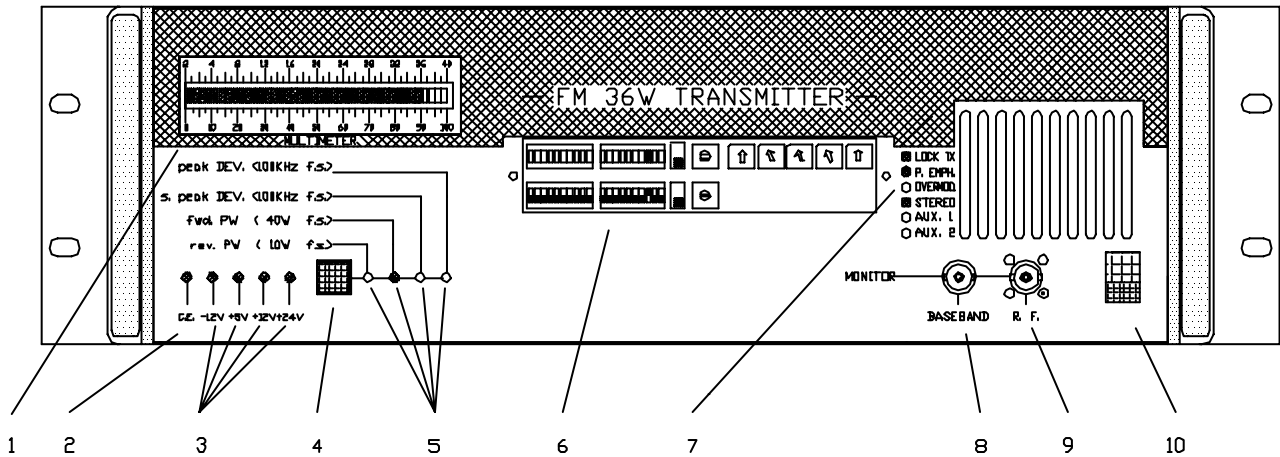

- | | | |
|----|--------------------------|---|
| 1 | FUNCTION METER | Multimeter measuring the functions (5)
Upper scale: Reflected (10Wf.s.) and Forward Power (40W f.s.)
Lower scale: Semi-peak and Peak deviation (100KHz f.s.) |
| 2 | CARRIER ENABLE | Led "ON": carrier presence (R.F. Power)
Connecting to ground the corresponding BNC connector on the rear panel (14) the Radio-Frequency Power is immediately switched-off, as the PLL remains locked. |
| 3 | POWER SUPPLY | Leds "ON": internal power supply voltages presence (-12, +5, +12, +24Vdc) |
| 4 | FUNCTION SELECTOR | Push it to select the measurement required (5). |
| 5 | FUNCTION LEDS | Leds "ON": they correspond to the measurement selected by pushing the function selector (4) and displayed by the Function Meter (1). |
| 6 | [SETTINGS] | Power and Frequency settings. |
| 7 | FUNCTIONS LEDS | LOCK TX : lighted when TX is locked
P.ENPH : lighted when Pre-emphasys is inserted (option MF and ST)
OVERMOD : lighted when the Audio input level exceeds the threshold (option MF and ST)
STEREO : lighted when internal Stereogenerator is inserted (option ST) |
| 8 | BASEBAND MONITOR | BNC connector: composite signal control 30Hz÷200KHz. |
| 9 | R.F. MONITOR | BNC connector: R.F. output for testing, -40dBc. |
| 10 | A.C. POWER SWITCH | |

REAR PANEL (OPTION MF-LM-ST))

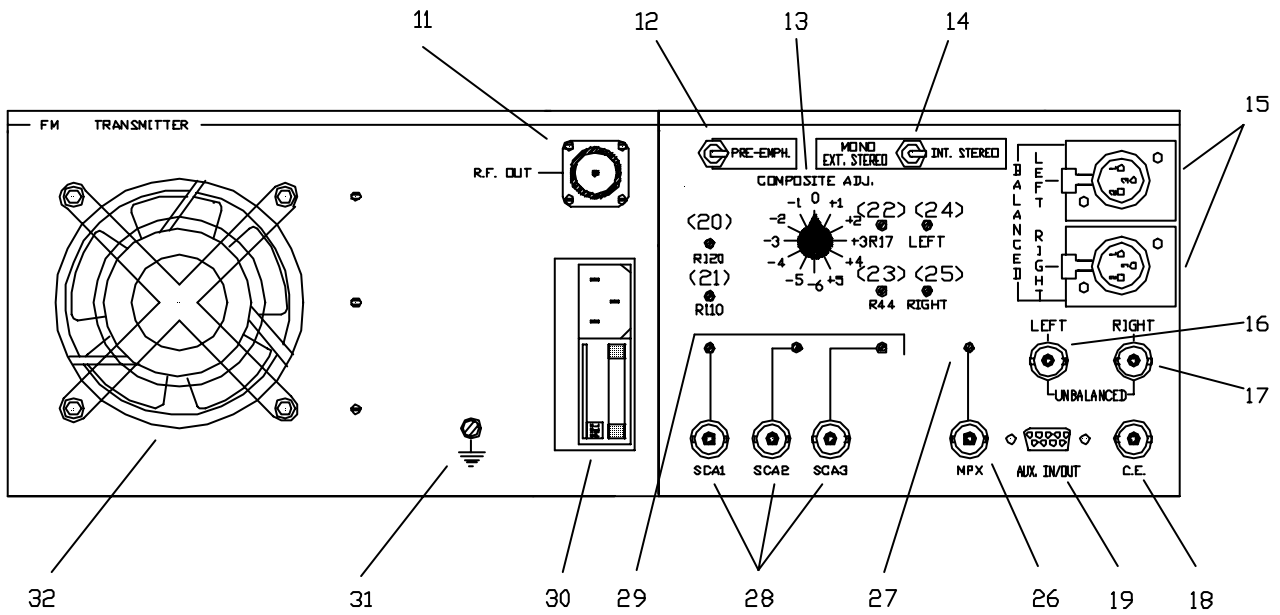

- | | | |
|----|-------------------------------|--|
| 11 | R. F. OUTPUT | Tip "N" connector, 50 . |
| 12 | PRE-EMPHASIS | switch, for pre-emphasis insertion, L/R Channel (option MF and ST) . |
| 13 | COMPOSITE ADJ. | multiswitch to adjust composite level, 1dB step (-6÷+5dB) (option MF and ST). |
| 14 | EXT/INT CODER | switch to select int. stereo operation or ext. mono /MPX operation (option ST) |
| 15 | L/R BALANCED | CANON XLR connector: pin 1= ground. pin 2= +Signal.
pin 3= -Signal (option MF and ST). |
| 16 | LEFT UNBALANCED | BNC connector for unbalanced Left Channel input (option MF and ST). |
| 17 | RIGHT UNBALANCED | BNC connector for unbalanced Right Channel input (option MF and ST). |
| 18 | CARRIER ENABLE | BNC connector carrier enable command: when connected to ground, the corresponding led (2) on the front panel and the R.F. power output are switched-off. |
| 19 | IN/OUT (DB9 connector) | pin 1 = 19KHz output for RDS sync. (TTL output) (option ST)
pin 5 = external clock input for synchronisation, 2500Hz TTL
pin 7 = external reflected power control (20mA control loop)
pin 8 = external forward power control (20mA control loop)
pin 6-9 = ground
pin 2-3-4= not used |
| 20 | R120 | ADJ multiturn trimmer to adjust the threshold of overmodulation led (i.e. 75KHz) (option MF and ST). |
| 21 | R110 | ADJ multiturn trimmer to adjust deviation meter (option MF and ST). |

22	R17	ADJ multiturn trimmer to adjust Left ch. pre-emphasis (option MF and ST).
23	R44	ADJ multiturn trimmer to adjust Right ch. pre-emphasis (option MF and ST).
24	LEFT ADJ.	ADJ multiturn trimmer to adjust Left channel level (option MF and ST).
25	RIGHT ADJ.	ADJ multiturn trimmer to adjust Right channel level (option MF and ST).
26	MPX	BNC connectors, MPX (or Mono) input (option MF and ST).
27	MPX ADJ.	Multiturn trimmer for MPX input level adjustment. The level is factory set at +6dBm to obtain ± 75 KHz dev.
28	SCA1, SCA2, SCA3	BNC connectors, SCA1, SCA2, SCA3 inputs (20KHz \div 200KHz flat)
29	SCA ADJ.	Multiturn trimmers for SCA1, SCA2, SCA3 input level adjustment. They are factory set at +6dBm to obtain ± 7.5 KHz dev.
30	A.C. LINE	ac Plug and Fuse Block & Voltage Change Plug (see Preface Chapter)
31	EARTH	Earth connection.
32	FAN	Fan, 110Vac.
33	MPX	BNC connectors, Balanced and unbalanced MPX inputs (option MX)

REAR PANEL (OPTION MX)

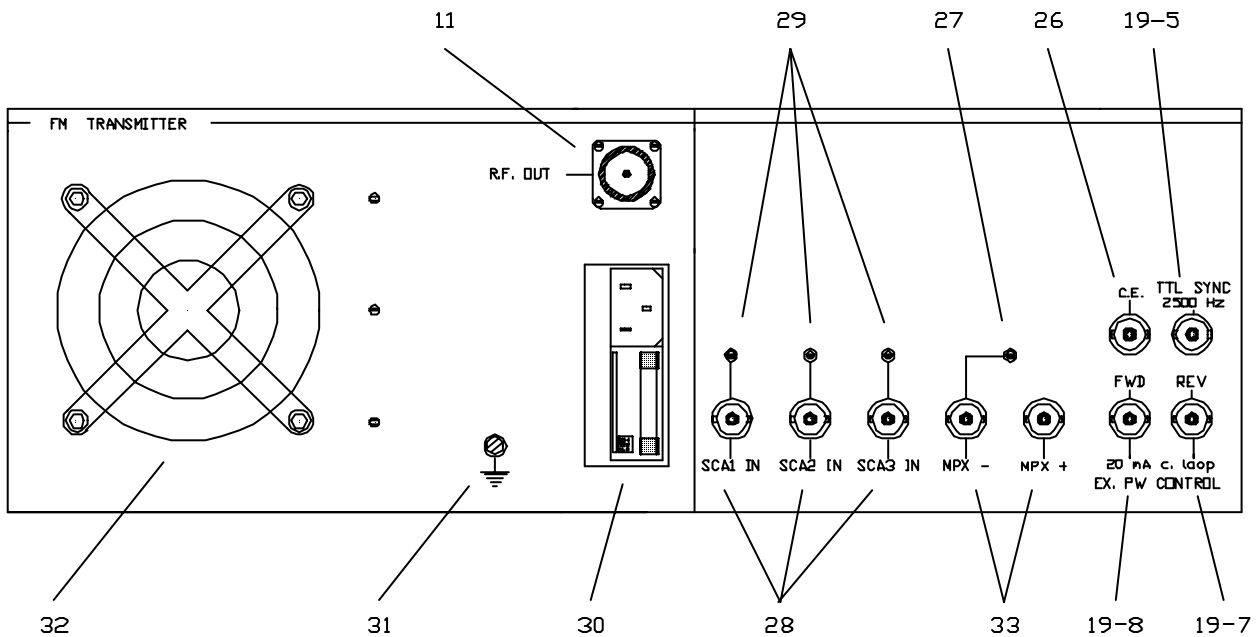

11	R. F. OUTPUT	Tipe "N" connector, 50 .
18	CARRIER ENABLE	BNC connector carrier enable command: when connected to ground, the corresponding led (2) on the front panel and the R.F. power output are switched-off.
19-5		BNC connector: external clock input for synchronisation, 2500Hz TTL
19-7		BNC connector: external reflected power control (20mA control loop)
19-8		BNC connector: external forward power control (20mA control loop)
27	MPX ADJ.	Multiturn trimmer for MPX input level adjustment. The level is factory set at +6dBm to obtain ± 75 KHz dev.
28	SCA1, SCA2, SCA3	BNC connectors, SCA1, SCA2, SCA3 inputs (20KHz \div 200KHz flat)
29	SCA ADJ.	Multiturn trimmers for SCA1, SCA2, SCA3 input level adjustment. They are factory set at +6dBm to obtain ± 7.5 KHz dev.
30	A.C. LINE	ac Plug and Fuse Block & Voltage Change Plug (see Preface Chapter)
31	EARTH	Earth connection.
32	FAN	Fan, 110Vac.
33	MPX	BNC connectors, Balanced and unbalanced MPX inputs (option MX)

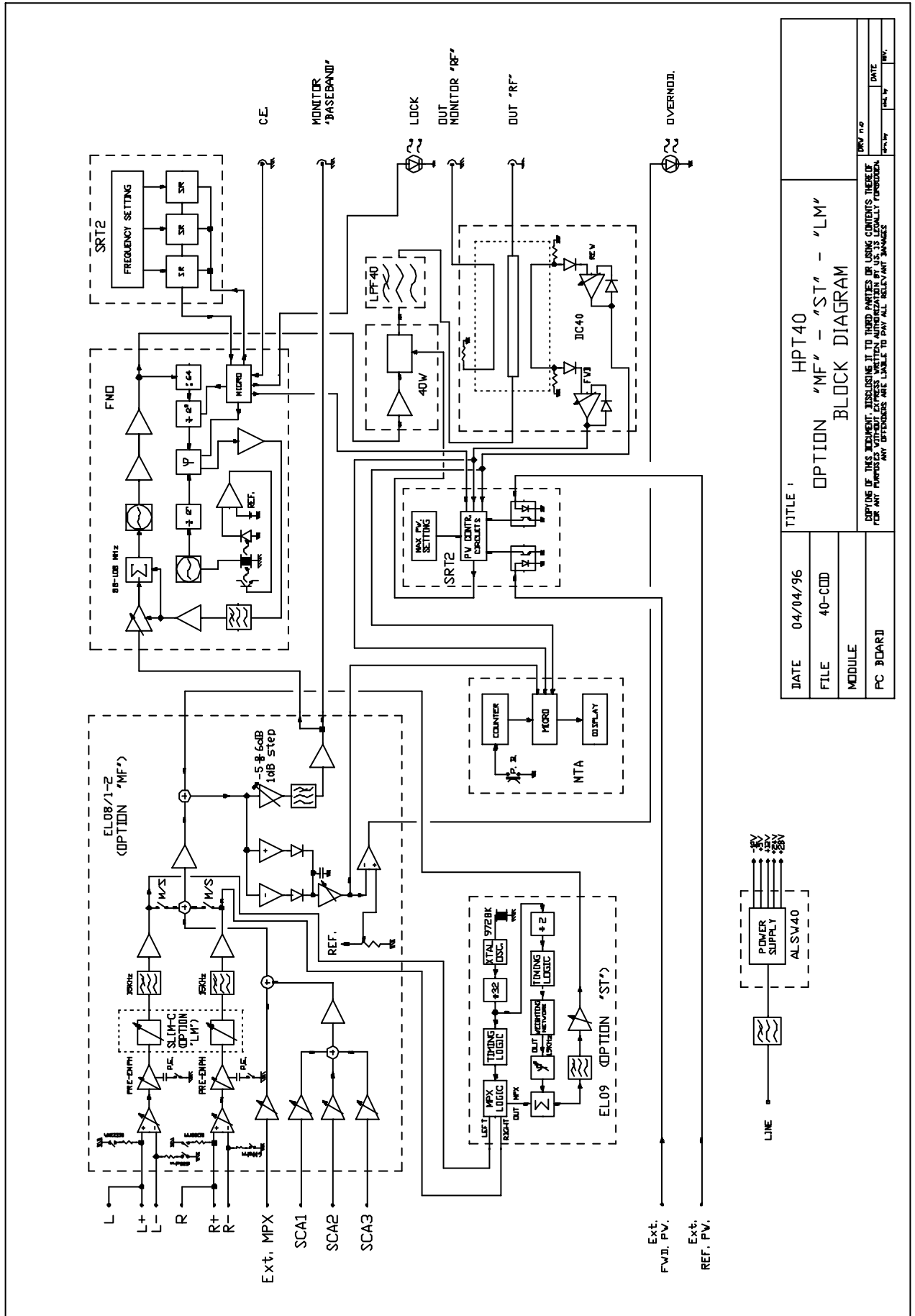

DATE	04/04/96	TITLE	HPT40
FILE	40-CDD	OPTION	'MF' - 'ST' - 'LM'
MODULE		BLOCK	DIAGRAM
PC BOARD			

COPYING OF THIS DOCUMENT, DISCLOSURE TO THIRD PARTIES OR USING CONTENTS THEREOF FOR ANY PURPOSES WITHOUT EXPRESS WRITTEN AUTHORIZATION BY U.S. IS LEGALLY PROHIBITED. ANY OFFENSES ARE LIABLE TO PAY ALL RELATED FEES AND COSTS.

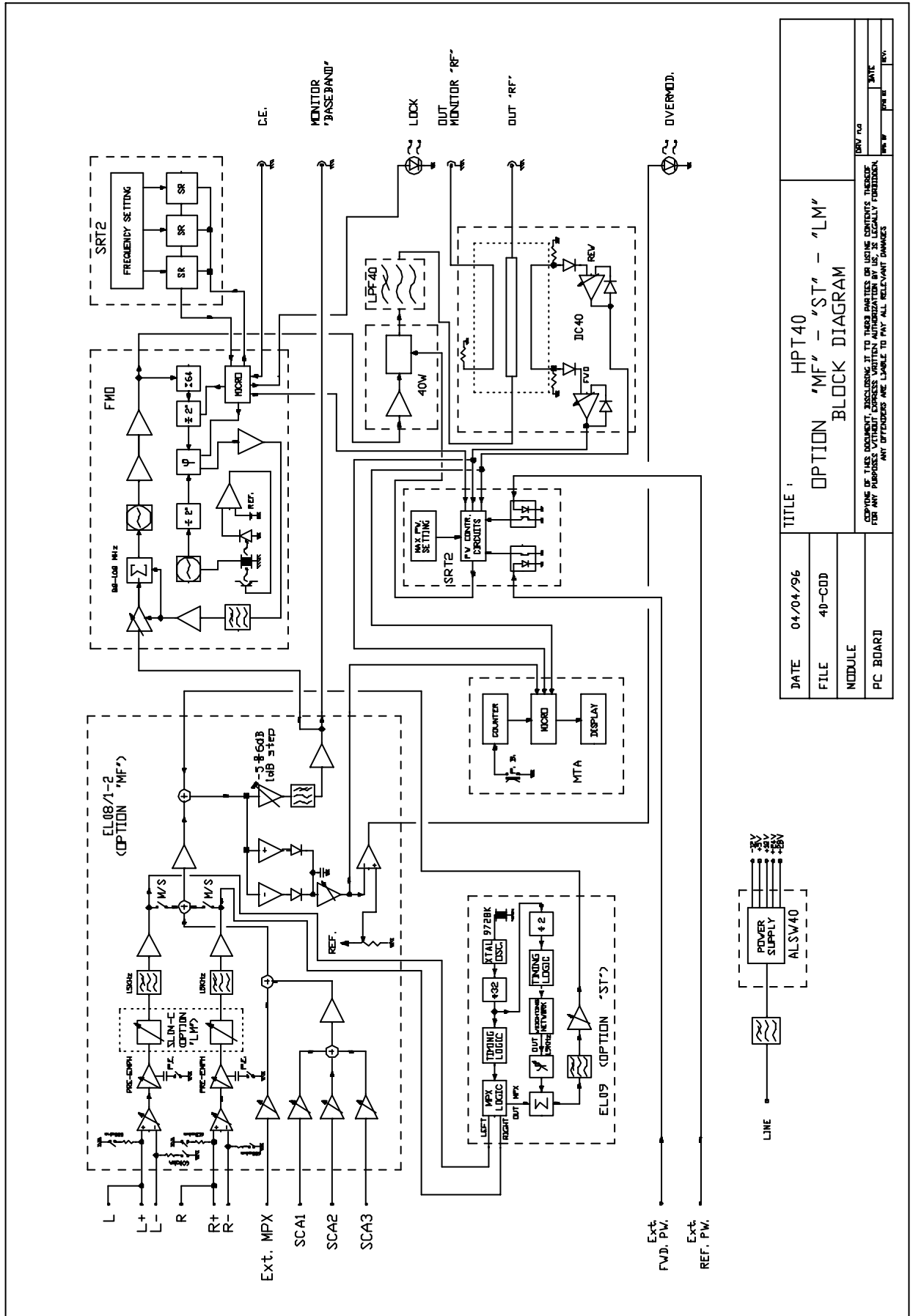

DATE	04/04/96	TITLE	HPT40
FILE	40-CDD	OPTION	'MF' - 'ST' - 'LM'
MODULE		BLOCK DIAGRAM	
PC BOARD			

GEORGE W. HUBBARD, ENGINEER, IN THE SERVICE OF THE UNITED STATES OF AMERICA, HEREBY CERTIFIES THAT THIS DOCUMENT IS THE PROPERTY OF THE UNITED STATES OF AMERICA AND IS LOANED TO YOU FOR YOUR INFORMATION ONLY. IT IS NOT TO BE REPRODUCED OR TRANSMITTED IN ANY FORM OR BY ANY MEANS, ELECTRONIC OR MECHANICAL, INCLUDING PHOTOCOPYING, RECORDING, OR BY ANY INFORMATION STORAGE AND RETRIEVAL SYSTEM, WITHOUT EXPRESS WRITTEN AUTHORIZATION BY THE FEDERAL COMMUNICATIONS COMMISSION. ANY OFFENDERS ARE LIABLE TO PAY ALL RELEVANT DAMAGES.

ELC SYSTEM

BEFORE SUPPLYING POWER, VERIFY THAT THE VOLTAGE OF THE AC POWER TO BE USED IS THE SAME AS THE SPECIFIED VOLTAGE

The power voltage for use is set at shipping, according to the specification when the order was received. If power voltage was not specified in the order, it is standard the 230Vac mode.

To change the standard specification to another, for example 110Vac, first remove the fuse in the AC line connector on the rear panel by sliding the plastic cover to the left side of the AC line connector and pulling the lever toward you. Then remove the voltage indicating panel from the fuse box and re-insert the voltage indicating panel so that 110V is displayed on the voltage indicating window on the lower of the fuse.

Finally insert the fuse in the box, slide the plastic cover to the right and connect the power cable to the AC line connector. Now you are ready to turn the power switch at the lower of the front panel ON.

When power is supplied, a self diagnostic test is running. The test sequence light the bar-leds on the Vu-meter and the control leds.

The internal dc voltages (-12, +5, +12, +24) are displayed by means of four leds. The device has a thermal compensated cristal, so warm it up for about 10 minutes to obtain the specified performance.

ELC SYSTEM

USER INSTRUCTIONS

The EXCITER can supply a Maximum RF Power of the 36W, in the frequency range 87.5 108MHz

Before supplying power and connect it to Transmission Antenna or Power Amplifier, is necessary to execute this procedure:

- A) Verify that the voltage of the ac power to be used is the same as the specified voltage. If is necessary to change the standard specification to another, for example 110Vac, first remove the fuse in the Power Entry Module Filter with IEC Plug, Voltage Selector and Fuse Block on the rear panel by sliding the plastic cover to the left side of the AC line connector and pulling the lever toward you. Then remove the voltage indicating panel from the fuse box and re-insert the voltage indicating panel so that 110V is displayed on the voltage indicating window on the lower of the fuse. Finally insert the fuse in the box, slide the plastic cover to the right and connect the power cable to the AC line connector.
- B) Connect a dummy load capable of handling at least 50W, to the N connector labeled "RF OUT." An in-line wattmeter is also recommended
- C) Remove the digiswitch cover on the front panel by removing the two screws holding it on. Set the transmission frequency by use of the rotary-switches provided. The transmission frequency may be set in 10KHz increments. The switch increments from left to right are 100MHz, 10MHz, 1MHz, 100KHz, and 10KHz. A red LED indicator is also provided to indicate when the VCO is locked.
- D) On the front panel, in the frequency select window , there are two banks of 10 switches and, by the label "MAX. SET OUTPUT POWER", there are two banks of 10 LED indicators. **The switches are used to set the maximum power, that the Transmitter shall not exceed.** The first bank of 10 switches represents the power from 2 to 20 watts, while the second bank represents the power from 22 to 40 watts. **THERE SHOULD NEVER MORE THAN "ONE" SWITCH ON AT ANY TIME.** In the case where the operator selects more than one switch the unit will not execute the sum of the power, however an incorrect reading will be displayed on the indicator
- E) Located to the left of the Power control switch banks are two singol switches located one above the other. The top switch selects the Internal or External control of Direct Power Output while the lower switch selects Internal or External control of Reflected Power Output. **Place both switches in the "down" position which selects Internal power control**
- F) To the left of the left control switches are two small Trimmers. Rotate both controls full clockwise

- G) Connect the equipment to the AC line and turn ON the power. Set the multimeter to the Direct Power Reading by pressing the square button until the red LED indicates the desired parameter has been selected.
- H) Wait for a few seconds and observe that the red lock indicator light (TX PLL LOCK), indicating that the VCO is locked in to the frequency selected on the front panel. The direct power reading will come up slowly (5 seconds)
- i) Adjust the top trimmer until the power does not go above the maximum desired power. Turning the trimmer counterclockwise will reduce the power.
- L) Turn the reflected power control trimmer fully counterclockwise. The power output should decrease. Remove the antenna cable (VSWR=) and adjust the trimmer so that the direct power output is approx. 4 watts. This adjustment sets the automatic fold-back control so that the HIGH VSWR conditions cause the transmitter to automatically go to a safe operating level
- M) Reconnect the dummy load and the RF power should automatically come back up the desired level and to remain in ALC. This indicates that the transmitter now sees the correct load.
- N) Remove power from the unit and connect the unit to the transmission antenna

40W SETTING

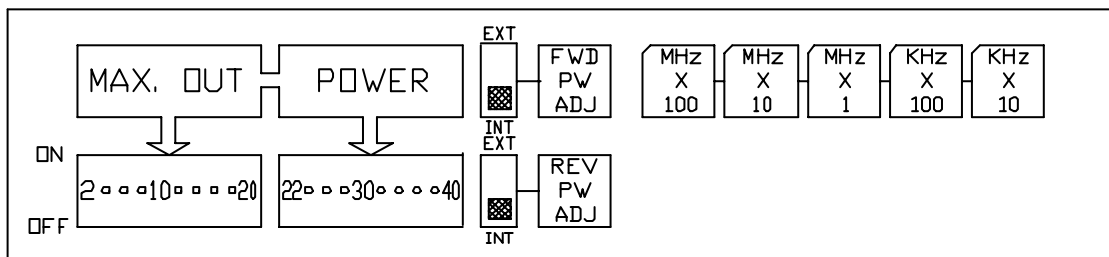

HPT40 MODULES DESCRIPTION

POWER SUPPLY (ALSW40 module)

This module supplies -12.5V, +5V, +12.5V, +24V, +28V DC Voltages

The input is composed of 3 x Rectifier Bridges (RD1, RD2, RD3). RD1 bridge, powered by an 8V rms secondary of the toroidal transformer, supplies DC voltage of +5V through the 7805 regulator, RD2 bridge, powered by a 16Vrms secondary, supplies, through the L200 regulator, DC voltage of +12V and supplies the switching circuit, that, supplies, through the 7912 regulator, DC voltage of -12V.

RD3 bridge, powered by an 28Vrms secondary of the toroidal transformer, supplies, through an appropriate regulation circuit, DC voltage of +28V-5A, to 40W RF module. From this voltage, the U5 regulator supplies DC Voltage of +24V.

LOW FREQUENCY CIRCUIT (BFI board) M version

The purpose of this module is to apply sound signals (mono, stereo, SCA) to the modulator. The input circuit for mono or stereo signals (with frequencies lower than 53kHz) is unbalanced with an input impedance of 0.6 or 10Kohm which may be selected by means of jumpers. The three unbalanced inputs for SCA signals accept input frequencies up to 200kHz.

After the first two stages, which allow regulation of the total gain, there is the pre-emphasis circuit by means of which variable time constants can be obtained between 40 and 80 microseconds (factory set at 50 μ S for CCIR, at 75 μ S for FCC)

The base band signal obtained in this way directly modulates the VCO, with a level of +6dB for maximum Deviation. On the module there is also a circuit to measure the level of the sound signal, whose output goes to the MTA board, for reading on the multimeter located on the front panel.

LOW FREQUENCY CIRCUIT (EL08/1-2 boards) MF and ST versions

The “low frequency input filter” module is composed of two overlaying boards housed in the rear of the rack in direct contact with the input connectors;

It has the task of controlling the various input signals (MPX, Left, Right, SCA 1,2,3), filtering them, and sending them either to the modulator or to the stereocoder; in addition, there is also a low-pass filter for the internal or external multiplex signal. There is provision to set the various levels of both the single signals and the composite signal; it is possible to insert pre-emphasis and adjust the level of the overmodulation indicator.

Input levels are normally calibrated for 0dBm, 6dBm, or 12dBm, while output which is present also as a VDU on the front panel is set at a fixed level of 6 dBm (1550mVrms).

On the right- or left-hand channel there are two elliptical filters to ensure excellent suppression of the low frequency signal spectrum for frequencies greater than 15kHz; at 19kHz attenuation typically exceeds 50dB, while ripple in the band is around 0.1dB.

The analog signals are switched by means of very low distortion and noise analog switches. The precision modulation intensity detector is peak-to-peak and gives error-free response up to and over 100kHz.

STEREO LIMITER CIRCUIT (SLIM board) MF/LM and S/LM versions

The SLIM board, located between EL081 and EL082 boards, is composed of a LIM circuit and it intends to limit the frequency deviation at $\pm 75\text{KHz}$; such circuit is inserted between the left and right audio inputs and the relevant 15KHz low pass filters. This circuit delivers three properly switched signals to an amplifier; this switching function is in relation with the audio level of the audio signal applied to the left and right channels. The intervention threshold is adjusted by the R1 trimmer, which automatically sets the positive and negative values.

If the audio input signal is lower than the threshold set, the audio input signal is delivered directly to the audio output without any level and phase variation.

If the audio input signal exceeds positively or negatively the thresholds set, a negative and positive voltage exactly equal to the threshold value is then delivered to the audio output.

The following low pass filter located at the EL081 board, eliminates the harmonics and eventual switching glitches caused by the audio signal clip.

The group delay of the low pass filter may originate small oscillations on the clip, but the level of these oscillations doesn't increase the deviation more than 1dB, even if the audio input level will double.

STEREO GENERATOR CIRCUIT (EL09 module) S version

The audio signals coming from the input boards containing the 15KHz audio filters enter the MPX module (EL09 board) at J1 and J2 respectively. They are then taken to the level of 2Vrms by U12 and U13 then enter the analog switches that work at a frequency of 608KHz.

This commutation frequency is a multiple of the pilot tone frequency (19KHz) and it is derived from a crystal oscillator (U3) operating at 9728KHz and from two shift-registers (U5). This makes it possible to have the commutation spurious emissions of the multiplex signal at a much greater frequency than the maximum frequency of the stereophonic signal and so they can easily be eliminated with a Bessel filter of the fifth order on the input boards. Since this Bessel filter's cut-off frequency is over 300KHz, its response in amplitude and phase within the 53 KHz is excellent and therefore does not prejudice separation of the left and right channels of the stereophonic signal.

The R8 trimmer is used to balance the two commutation signals and should be adjusted to have maximum suppression of the 38KHz.

The R12 trimmer polarizes the analog switches and adjusts itself for minimum distortion of the decoded signal.

The 19KHz subcarrier is also generated by the 9728KHz crystal; after the integrated circuit U3 has been divided by U3 with its eight "shifted" outputs, it makes it possible to build the pilot tone frequency by approximation by means of a weighted sum. The amplitude of the 19 KHz pilot tone is adj by R59, while R57 adj its phase.

The multiplex signal is summed with the pilot tone frequency with a suitable weight through the operational amplifiers U15 and U16; these have a continuous coupling and their offset is zeroed by R36; the R70 trimmer adj the level of the output signal, normally adj at +6dBm, same value of the EL09 audio inputs

VCO CIRCUIT (FMO module)

This module includes a section enclosed in an aluminium screened box containing a very-low-noise FET oscillator and relative amplifier, a modulation circuit whose great linearity throughout the FM band is ensured by an original compensating circuit, and a VCO input for the frequency control loop.

Outside this aluminium screened box there is the section for digital frequency synthesising, obtained by means of a microprocessor that acquires the frequency set on the front panel by means of dip-switches and it programs a series of dividers with the purpose of lowering the frequency of the VCO to the comparison level, which may be obtained by the crystal thermostatic oscillator located inside the module, or by using an outside sample source with a frequency of 2500Hz.

MULTIMETER CIRCUIT (MTA board)

The MTA board displays on the front panel the working condition of the most important transmitter parameters

The power supply voltages (-12, +5, +12, +24Vdc) are displayed from 4 leds located on the left side of front panel

The analog voltages showing the Direct Power, Reflected Power, peak and semi-peak modulation, are displaying from “BAR-GRAF” with a resolution of the 40 leds that make sure a reading accuracy to agree with measurement trasductor. The selected function is displayed from respective led.

The Deviation Measurement (full-scale is100KHz) is derived from peak to peak detector circuit with response very accuracy also for MPX signals. Moreover is displaying the semi-peak modulation with the aid of a microprocessor that read the maximum deviation peak every 300msec. This function is useful in order to verify the frequency deviation value with “musical” signal. Infact the choice of use of the “BAR-GRAF” is necessary in order to have a good response with “music” signal.

The led C.E. (carrier enable) shows the enable of the RF POWER MODULE, (with VCO module always frequency locked), in case the transmitter is used in a Active Reserve System

RF AMPLIFIER AND POWER CONTROL SECTION (40W, LPF40, DC40 AND SRT modules)

RF AMPLIFIER SECTION (40W, LPF40 and DC40 modules)

This includes the RF Amplifier, the Low Pass Filter and the Directional Coupler modules. The first represents a power amplifier with gain higher than 36 dB and bandwidth 87.5-108 MHz; the typical input exciting power is 10dBm (+/-3dBm). All the stages are in AB Class to ensure an adequate stability even with very low output powers. The trimmer R10 fixes the polarization of the second stage, whereas the R17

fixes that of the last one. The amplifier which supplies more than 60W output power on the whole range, is followed by a Low Pass Filter of 9th order which ensures, with a ripple in lower band of 0.1dB, a rejection of the harmonics better than 70 dB; its typical insertion loss is lower than 0.3 dB within the 87.5-108Mhz, and exceeds 42dB at 176Mhz. After the Low Pass Filter, before the output antenna connector, we find the Directional Coupler module (strip-line configuration) which, besides showing the direct and reflected power, controls the figures and grants a protection of the Power Transistor in case of wrong functioning of the output load. This circuit is completed shield, ensuring a typical decoupling between direct and reflected power higher than 20dB and therefore a reading precision better than 5%. The detected voltages, proportional to the two RF powers, go on two operational amplifiers which amplify their value, taking into consideration the thermic drift of the detector diodes. The Directional Coupler Insertion Loss is lower than 0.2dB.

POWER CONTROLLER CIRCUIT (SRT board)

This board, fixed on the internal side of the front panel, has two functions: the acquisition (by means of 5 decimal dip-switches) of the frequency, to be sent to the microprocess located on the FMO module by means of a shift-register PISO, and the control of the directed and reflected powers. This control is effected by pre-setting 20 dip-switches of the total desired power (2 40W) and, inside it, of the directed and reflected power, by means of a trimmer.

By means of two optoinsulated inputs, it is possible to control the power of an external amplifier driven by this unit, provided it is supplied with the suitable directional coupler.

ELC SYSTEM

CABLE

<i>COLOUR</i>	<i>FUNCTION</i>	<i>EQUIPMENT</i>
RED	+12Vdc	All the equipments.
GREY	+5Vdc	All the equipments.
DARKBLUE	+24Vdc	All the equipments.
WHITE	-12Vdc	All the equipments.
GREEN	R.F. field measure	RXG, RXFM, RX2G,HPT-FMR, HPT-STL
BROWN	Carrier Detect output	RXG, RXFM, RX2G, HPT-FMR, HPT-STL
BLUE	D.T.-T: Data Transfer Tx frequency setting	Exciter, transmitter and transposer.
CYAN	Carrier Detect led	Receiver and transposer.
YELLOW	Tx locked led	Exciter, transmitter and transposer.
PINK	AB-FIN: power enable	Exciter, transmitter and transposer.
ORANGE	Carrier Enable	Exciter, transmitter and transposer.
BLACK	ground	All the equipments..
PINK-BLACK	Over-Modulation led	/Cod option for exciter and transmitter.
DARKBLUE-BLACK	Rx locked led	Receiver and trasposer.
YELLOW-BLACK	CK-T: clock for Tx frequency setting board	Exciter, transmitter and transposer.
CYAN-BLACK	D.T.-R: Data Transfer Rx frequency setting	Transposer.
GREY-BLACK	PE-R: Parallel Enable for Rx frequency setting board	Transposer.
RED-BLACK	IN-PR: Tx reflected power measure	Transmitter/P, exciter and transposer.
BLUE-WHITE	EX-PD: External Forward Power measure	Transmitter/P, exciter and transposer.
GREEN-WHITE	IN-PD: Tx forward power measure	Transmitter/P, exciter and e transposer.
YELLOW-WHITE	CK-R: clock for Rx frequency setting board	Receiver and transposer.
GREY-WHITE	IN-V: Tx amplifier module driving voltage	Transmitter/P, exciter and transposer.
ORANGE-WHITE	Pre-emphasis inserted.	/Cod option for exciter and trasmitter.
RED-DARKBLUE	Deviation meter	
WHITE-DARKBLUE	Power enabling for A2G, AXG1, FX6 and YU6 modules	TXG, TX6 and TX2G.

YELLOW-RED	VCO voltage measure	
ORANGE-RED	Internal Stereo-generator inserted	/Cod option for exciter and trasmitter.
CYAN-RED	TXG amplifier module driving voltage	TXG with power adjusting on the rear panel.
BLUE-RED	TXG amplifier module driving voltage	TXG with power adjusting on the rear panel.
PINK-CYAN	EX-PR: external reflected power measure	Trasmitter/P, exciter and transposer.
GREEN-BROWN	PE-T: Parallel Enable for Tx frequency setting board	Exciter, tranmitter and transposer.
CYAN-WHITE	Reset for microprocessor	All the equipments

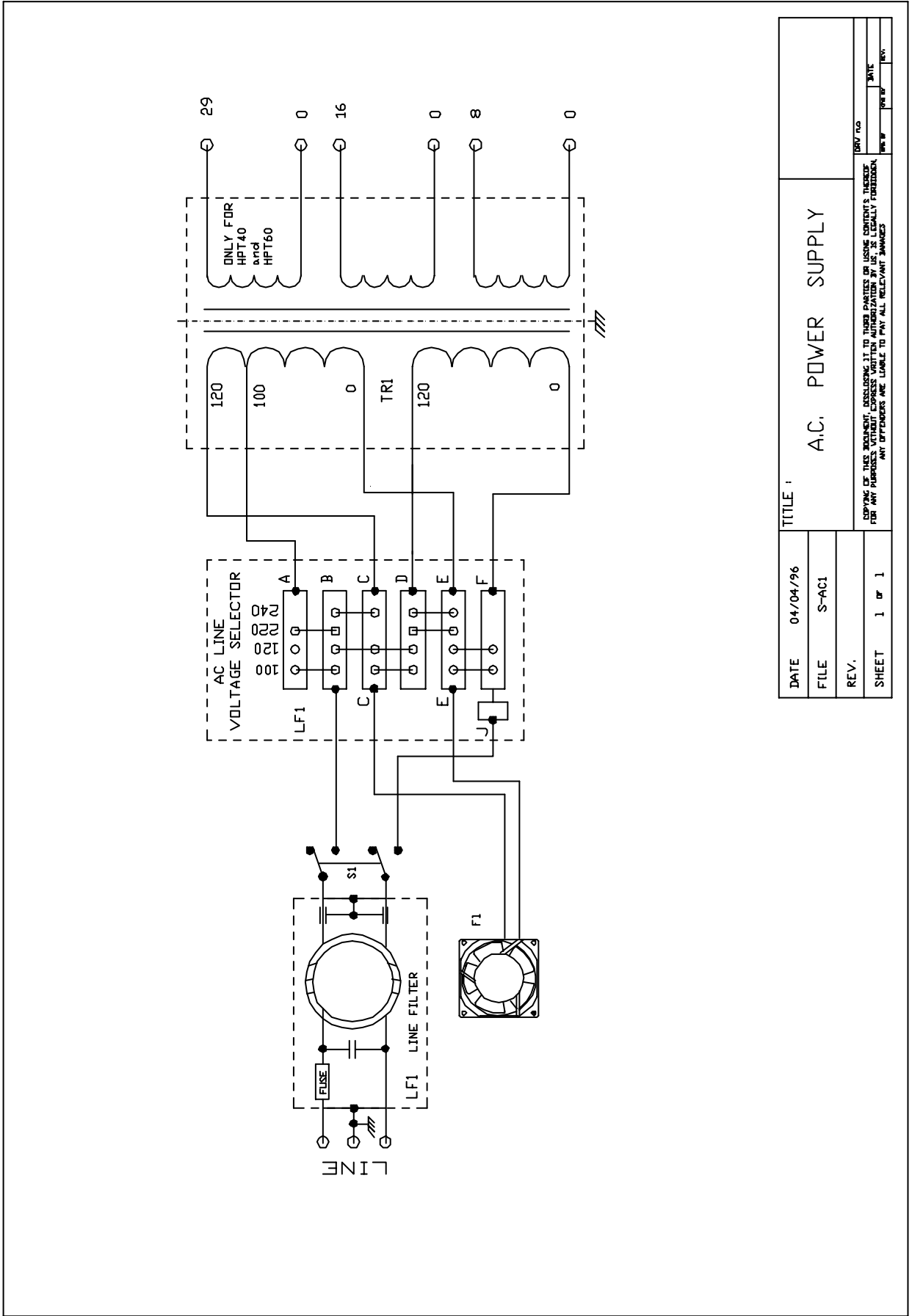

DATE	04/04/96	TITLE	A.C. POWER SUPPLY
FILE	S-AC1		
REV.			
SHEET	1 OF 1		
		DRW'N BY	DATE
		CHK'D BY	REV.

REPEATING OF THIS DOCUMENT, INCLUDING IT TO OTHER PARTS OF ISSUE ORDERS, IS PROHIBITED WITHOUT EXPRESS WRITTEN AUTHORIZATION BY US. IS LEGALLY FORBIDDEN. ANY OFFENDERS ARE LIABLE TO PAY ALL RELEVANT DAMAGES.

A.C. PLUG-IN PART LIST

LF1	POWER ENTRY MODULE WITH FILTER	CORCOM
S1	BIPOLAR LINE SWITCH WITH LAMP	
TR1	TOROIDAL TRANSFORMER	150VA
F1	ASSIAL FAN	110V A.C.
F2	6X32 FUSE	

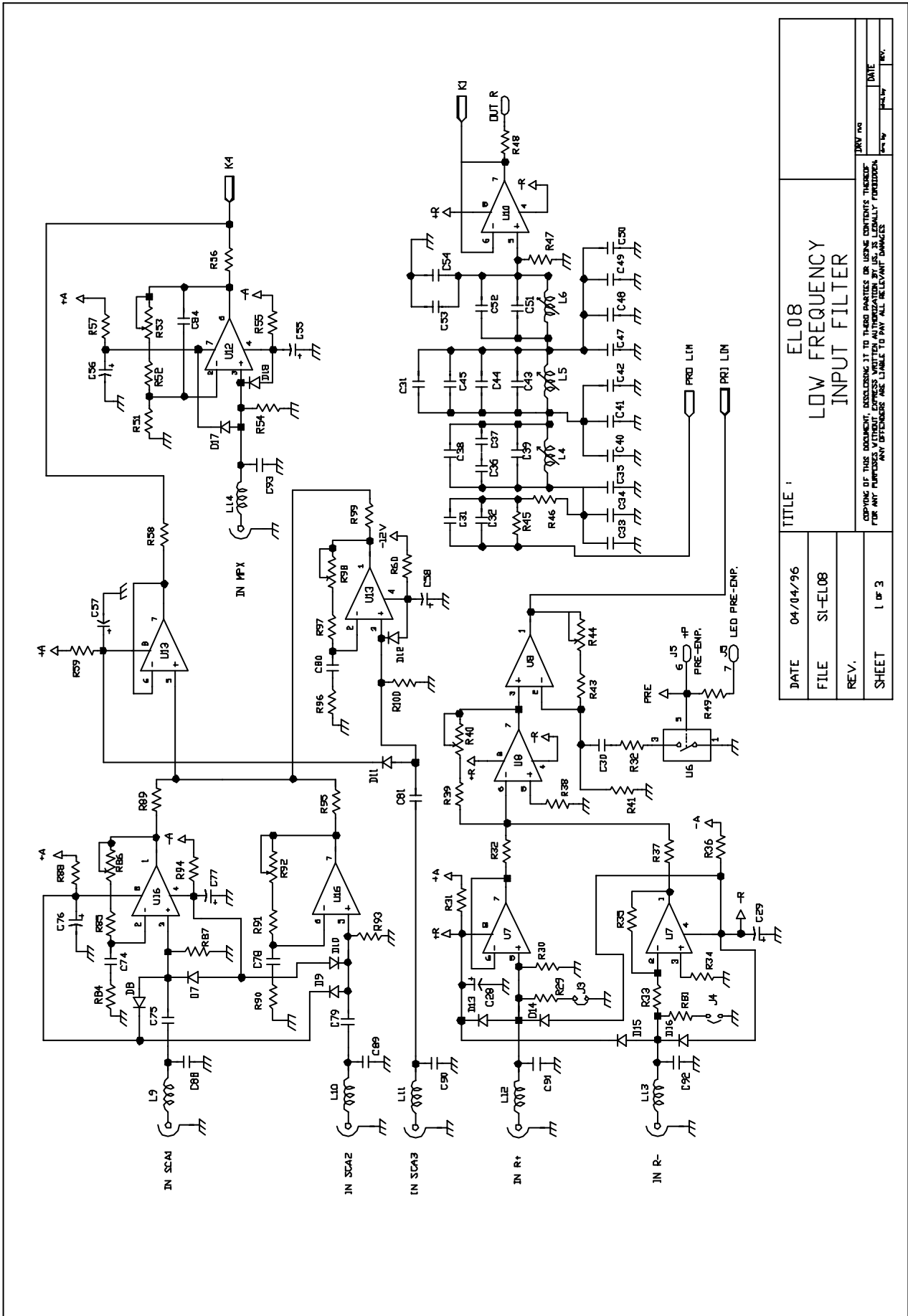

DATE	04/14/96	TITLE 1	EL08
FILE	SI-EL08	LOW FREQUENCY	INPUT FILTER
REV.			
SHEET	1 of 3		

DRYING OF THIS DOCUMENT, DISSEMINATION, OR REPRODUCTION OF THIS DOCUMENT WITHOUT EXPRESS WRITTEN AUTHORIZATION BY U.S. IS LEGALLY PROHIBITED. FOR ANY OFFENSES ARE LIABLE TO PAY ALL RELEVANT DAMAGES.

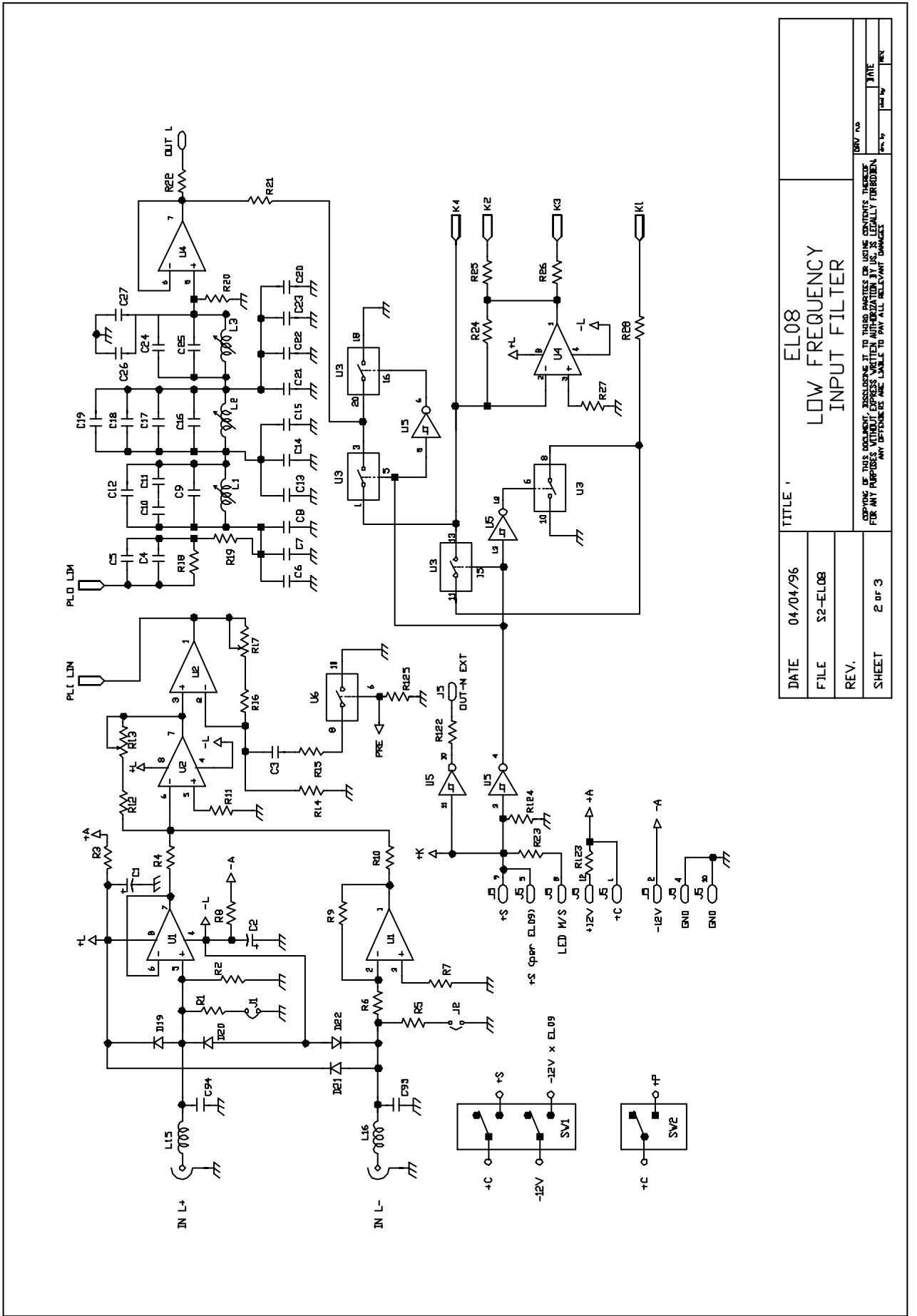

DATE	04/04/96	TITLE	EL08
FILE	S2-EL08	LOW FREQUENCY INPUT FILTER	
REV.			
SHEET	2 of 3		

DRW NO. _____
 DATE _____
 REV. BY _____
 CHECK BY _____

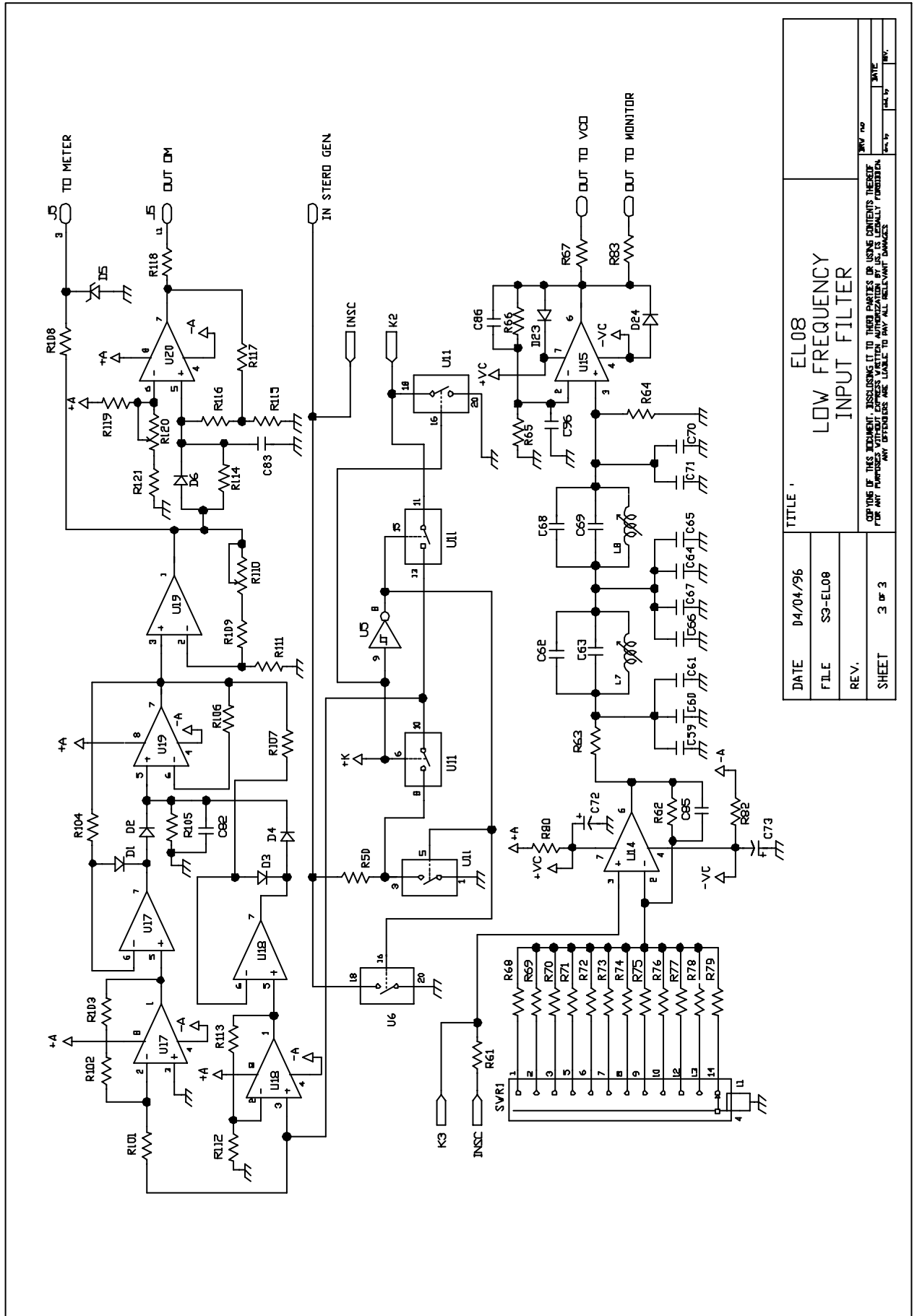

DATE		04/04/96	
FILE		S9-EL08	
REV.			
SHEET		3 OF 3	
TITLE		EL08 LOW FREQUENCY INPUT FILTER	
<small> COPYING OF THIS DOCUMENT, IN WHOLE OR IN PART, IS PROHIBITED WITHOUT THE WRITTEN PERMISSION OF THE ORIGINAL AUTHOR. ANY REPRODUCTION IS AT THE USER'S RISK. </small>			
REV. NO.	DATE	BY	

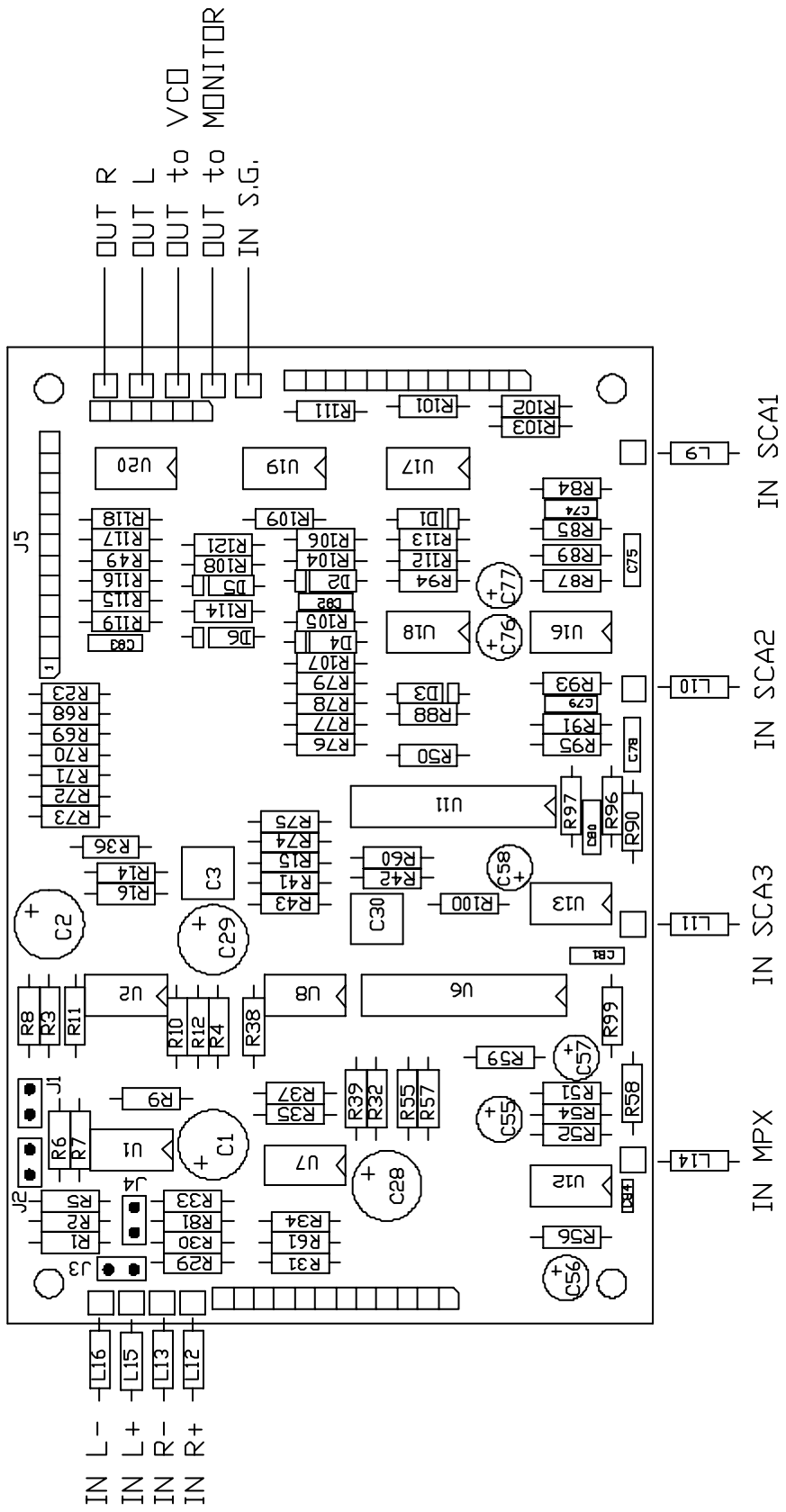

DATE		04/04/96	
FILE		EL08-2	
PC BOARD		EL08/2	
SHEET		1 of 3	
TITLE : EL08 LOW FREQUENCY INPUT FILTER			
<small> BEFORE USE WITHOUT PROSECUTE IT TO YOUR PARTS OR USING COMPONENTS IN THESE FOR ANY PURPOSES WITHOUT EXPRESS WRITTEN AUTHORIZATION BY J.S. IS LEGALLY FORBIDDEN. ANY OFFENDERS ARE LIABLE TO PAY ALL RELEVANT DAMAGES. </small>			
REV. NO.	DATE	BY	REV.

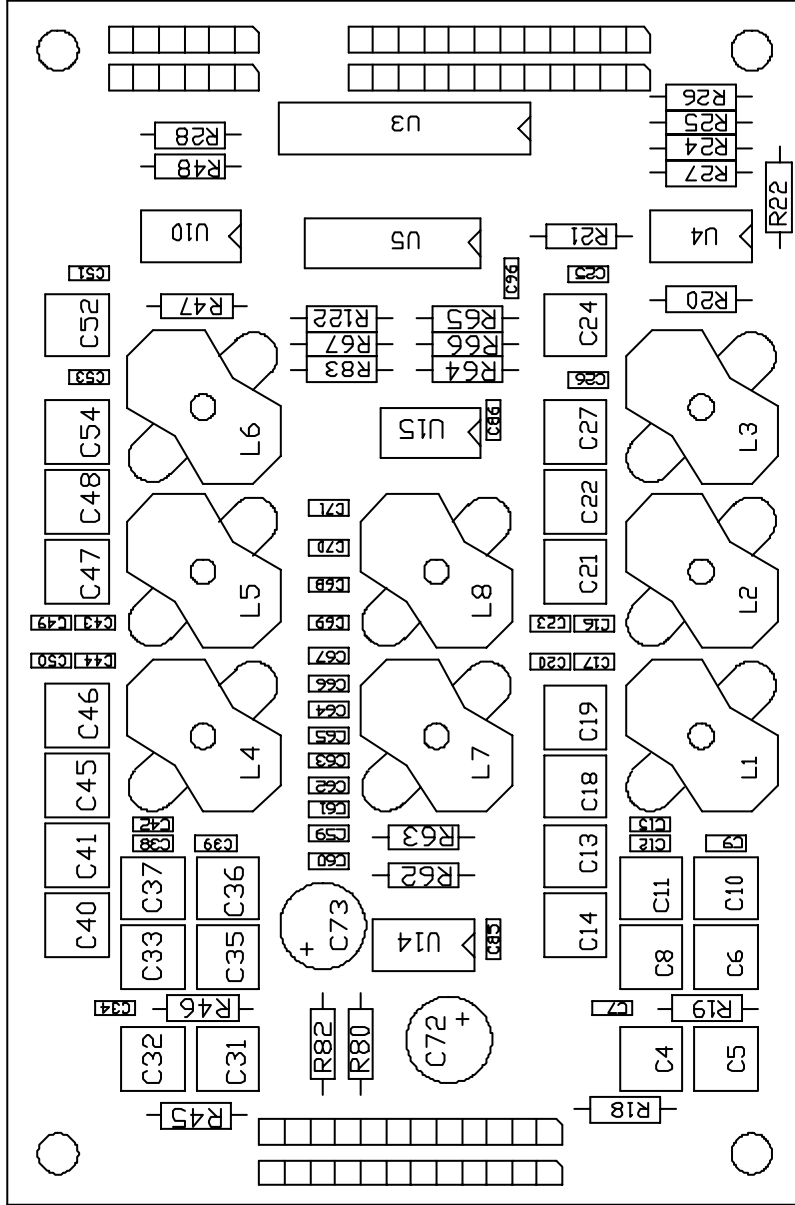

DATE		04/04/96	
FILE		EL08-2	
PC BOARD		EL081B	
SHEET		2 of 3	
TITLE 1			
EL08 LOW FREQUENCY INPUT FILTER			
REV. NO. DATE BY CHECKED BY			
COPYING OF THIS DOCUMENT, INCLUDING IT TO THIRD PARTIES OR USING CONTENTS THEREOF FOR ANY PURPOSES WITHOUT EXPRESS WRITTEN AUTHORIZATION BY US, IS LEGALLY FORBIDDEN. ANY OFFENSES ARE LIABLE TO PAY ALL RELEVANT DAMAGES.			

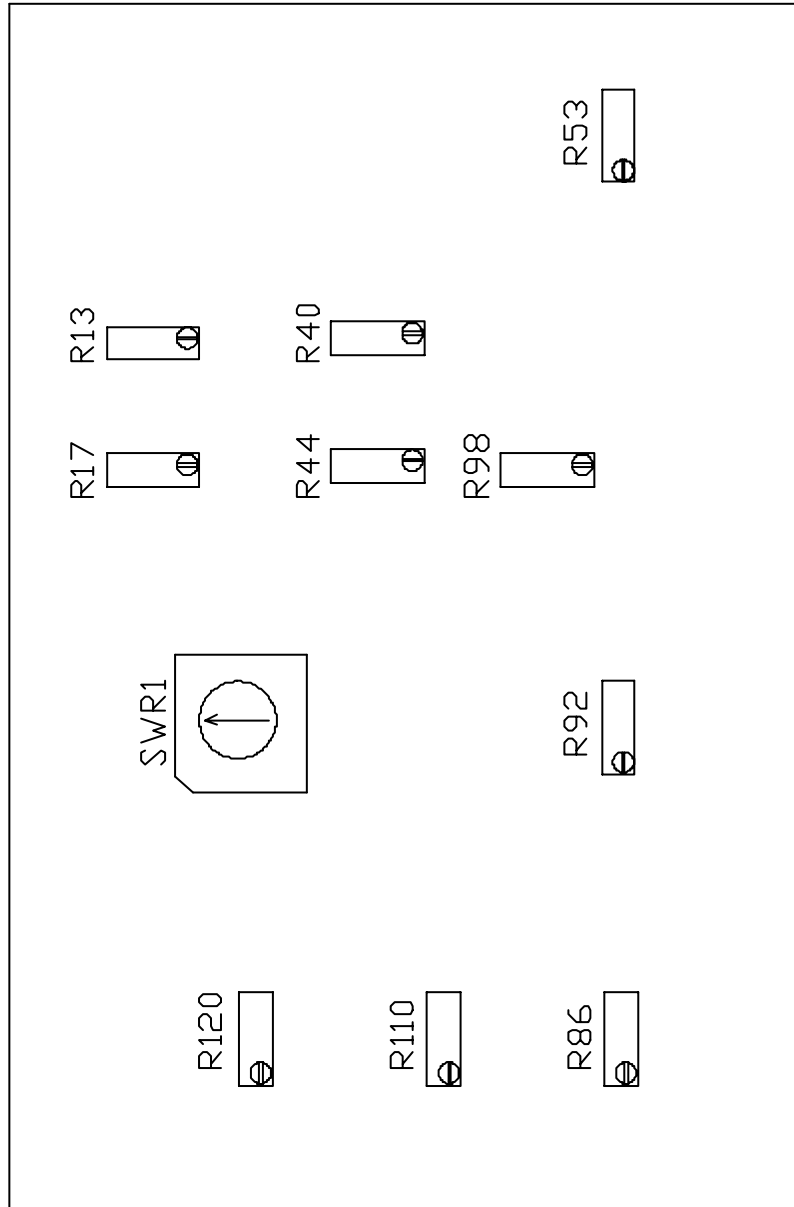

DATE	04/04/96	TITLE 1	EL08
FILE	EL08-3	LOW FREQUENCY INPUT FILTER	
PC BOARD	EL08/2	REV. NO.	
SHEET	3 OF 3	DATE	

COPYING OF THIS DOCUMENT, INCLUDING IT TO THIRD PARTIES OR USING CONTENTS THEREOF FOR ANY PURPOSES WITHOUT EXPRESS WRITTEN AUTHORIZATION BY U.S. IS LEGALLY PROHIBITED. ANY OFFENSES ARE LIABLE TO PAY ALL RELEVANT DAMAGES.

EL08/1-2 BOARD PART LIST

R1	RESISTOR 1% 0,25W	680	R52	RESISTOR 1% 0,25W	22
R2	RESISTOR 1% 0,25W	10K	R53	TRIMMER 10T	10K
R3	RESISTOR 1% 0,25W	270	R54	RESISTOR 1% 0,25W	10K
R4	RESISTOR 1% 0,25W	2.2K	R55	RESISTOR 1% 0,25W	270
R5	RESISTOR 1% 0,25W	680	R56	RESISTOR 1% 0,25W	2.2K
R6	RESISTOR 1% 0,25W	10K	R57	RESISTOR 1% 0,25W	
R7	RESISTOR 1% 0,25W	10K	R58	RESISTOR 1% 0,25W	8.2K
R8	RESISTOR 1% 0,25W	270	R59	RESISTOR 1% 0,25W	270
R9	RESISTOR 1% 0,25W	10K	R60	RESISTOR 1% 0,25W	10K
R10	RESISTOR 1% 0,25W	2.2K	R61	RESISTOR 1% 0,25W	1.2K
R11	RESISTOR 1% 0,25W	1K	R62	RESISTOR 1% 0,25W	1K
R12	RESISTOR 1% 0,25W	1.2K	R63	RESISTOR 1% 0,25W	1.5K
R13	TRIMMER 10T	10K	R64	RESISTOR 1% 0,25W	1.5K
R14	RESISTOR 1% 0,25W	6.8K	R65	RESISTOR 1% 0,25W	10K
R15	RESISTOR 1% 0,25W	10	R66	RESISTOR 1% 0,25W	10K
R16	RESISTOR 1% 0,25W	1K	R67	RESISTOR 1% 0,25W	330
R17	TRIMMER 10T	1K	R68		
R18	RESISTOR 1% 0,25W	1K	R69	RESISTOR 1% 0,25W	8.2K
R19	RESISTOR 1% 0,25W	1.2K	R70	RESISTOR 1% 0,25W	3.9K
R20	RESISTOR 1% 0,25W	2.2K	R71	RESISTOR 1% 0,25W	2.4K
R21	RESISTOR 1% 0,25W	1.2K	R72	RESISTOR 1% 0,25W	1.7K
R22	RESISTOR 1% 0,25W	47	R73	RESISTOR 1% 0,25W	1.3K
R23	RESISTOR 1% 0,25W	820	R74	RESISTOR 1% 0,25W	1K
R24	RESISTOR 1% 0,25W	1.2K	R75	RESISTOR 1% 0,25W	820
R25	RESISTOR 1% 0,25W	10K	R76	RESISTOR 1% 0,25W	680
R26	RESISTOR 1% 0,25W	1.2K	R77	RESISTOR 1% 0,25W	470
R27	RESISTOR 1% 0,25W	10K	R78	RESISTOR 1% 0,25W	390
R28	RESISTOR 1% 0,25W	1.2K	R79	RESISTOR 1% 0,25W	3.32K
R29	RESISTOR 1% 0,25W	680	R80	RESISTOR 1% 0,25W	10K
R30	RESISTOR 1% 0,25W	10K	R81	RESISTOR 1% 0,25W	680
R31	RESISTOR 1% 0,25W	270	R82	RESISTOR 1% 0,25W	10K
R32	RESISTOR 1% 0,25W	2.2K	R83	RESISTOR 1% 0,25W	47
R33	RESISTOR 1% 0,25W	10K	R84	RESISTOR 1% 0,25W	8.2K
R34	RESISTOR 1% 0,25W	10K	R85	RESISTOR 1% 0,25W	330
R35	RESISTOR 1% 0,25W	10K	R86	TRIMMER 10T	50K
R36	RESISTOR 1% 0,25W	270	R87	RESISTOR 1% 0,25W	10K
R37	RESISTOR 1% 0,25W	2.2K	R88	RESISTOR 1% 0,25W	270
R38	RESISTOR 1% 0,25W	1K	R89	RESISTOR 1% 0,25W	10K
R39	RESISTOR 1% 0,25W	1.2K	R90	RESISTOR 1% 0,25W	8.2K
R40	TRIMMER 10T	10K	R91	RESISTOR 1% 0,25W	330
R41	RESISTOR 1% 0,25W	6.8K	R92	TRIMMER 10T	50K
R42	RESISTOR 1% 0,25W	10	R93	RESISTOR 1% 0,25W	10K
R43	RESISTOR 1% 0,25W	1K	R94	RESISTOR 1% 0,25W	270
R44	TRIMMER 10T	1K	R95	RESISTOR 1% 0,25W	10K
R45	RESISTOR 1% 0,25W	1K	R96	RESISTOR 1% 0,25W	8.2K
R46	RESISTOR 1% 0,25W	1.2K	R97	RESISTOR 1% 0,25W	330
R47	RESISTOR 1% 0,25W	2.2K	R98	TRIMMER 10T	50K
R48	RESISTOR 1% 0,25W	47	R99	RESISTOR 1% 0,25W	10K
R49	RESISTOR 1% 0,25W	820	R100	RESISTOR 1% 0,25W	10K
R50	RESISTOR 1% 0,25W	10K	R101	RESISTOR 1% 0,25W	10K
R51	RESISTOR 1% 0,25W	3.3K	R102	RESISTOR 1% 0,25W	10K

R103	RESISTOR 1% 0,25W	10K	C37	POLICARB. CAPACITOR	1.5nF
R104	RESISTOR 1% 0,25W	5.6K	C38	CERAMIC CAPACITOR	120pF
R105	RESISTOR 1% 0,25W	2.7M	C39	CERAMIC CAPACITOR	8.2pF
R106	RESISTOR 1% 0,25W	3.9K	C40	POLICARB. CAPACITOR	3.3nF
R107	RESISTOR 1% 0,25W	5.6K	C41	POLICARB. CAPACITOR	2.7nF
R108	RESISTOR 1% 0,25W	1K	C42	CERAMIC CAPACITOR	100pF
R109	RESISTOR 1% 0,25W	3.9K	C43	CERAMIC CAPACITOR	100pF
R110	TRIMMER 10T	20K	C44	CERAMIC CAPACITOR	120pF
R111	RESISTOR 1% 0,25W	10K	C45	POLICARB. CAPACITOR	2.2nF
R112	RESISTOR 1% 0,25W	10K	C46	POLICARB. CAPACITOR	2.2nF
R113	RESISTOR 1% 0,25W	10K	C47	POLICARB. CAPACITOR	2.2nF
R114			C48	POLICARB. CAPACITOR	2.7nF
R115	RESISTOR 1% 0,25W	47K	C49	CERAMIC CAPACITOR	120pF
R116	RESISTOR 1% 0,25W	2.7M	C50	CERAMIC CAPACITOR	100pF
R117	RESISTOR 1% 0,25W	1M	C51	CERAMIC CAPACITOR	20pF
R118	RESISTOR 1% 0,25W	1K	C52	POLICARB. CAPACITOR	3.3nF
R119	RESISTOR 1% 0,25W	10K	C53	CERAMIC CAPACITOR	100pF
R120	TRIMMER 10T	10K	C54	POLICARB. CAPACITOR	2.7nF
R121	RESISTOR 1% 0,25W	1K	C55	ELECTROLYTIC CAPACITOR	47 F
R122	RESISTOR 1% 0,25W		C56	ELECTROLYTIC CAPACITOR	47 F
C1	ELECTROLYTIC CAPACITOR	220 F	C57	ELECTROLYTIC CAPACITOR	47 F
C2	ELECTROLYTIC CAPACITOR	220 F	C58	ELECTROLYTIC CAPACITOR	
C3	POLICARB. CAPACITOR	47nF	C59	CERAMIC CAPACITOR	100pF
C4	POLICARB. CAPACITOR	6.8nF	C60	CERAMIC CAPACITOR	100pF
C5	POLICARB. CAPACITOR		C61	CERAMIC CAPACITOR	2.2pF
C6	POLICARB. CAPACITOR	1.8nF	C62	CERAMIC CAPACITOR	18pF
C7	CERAMIC CAPACITOR	100pF	C63	CERAMIC CAPACITOR	
C8	CERAMIC CAPACITOR	2.7nF	C64	CERAMIC CAPACITOR	12pF
C9	CERAMIC CAPACITOR	8.2pF	C65	CERAMIC CAPACITOR	100pF
C10	POLICARB. CAPACITOR	1.5nF	C66	CERAMIC CAPACITOR	150pF
C11	POLICARB. CAPACITOR	1.5nF	C67	CERAMIC CAPACITOR	150pF
C12	CERAMIC CAPACITOR	120pF	C68	CERAMIC CAPACITOR	15pF
C13	POLICARB. CAPACITOR	3.3nF	C69	CERAMIC CAPACITOR	
C14	POLICARB. CAPACITOR	2.7nF	C70	CERAMIC CAPACITOR	47pF
C15	CERAMIC CAPACITOR	100pF	C71	CERAMIC CAPACITOR	100pF
C16	CERAMIC CAPACITOR	100pF	C72	ELECTROLYTIC CAPACITOR	
C17	CERAMIC CAPACITOR	120pF	C73	ELECTROLYTIC CAPACITOR	
C18	POLICARB. CAPACITOR	2.2nF	C74	POLICARB. CAPACITOR	2.2nF
C19	POLICARB. CAPACITOR	2.2nF	C75	POLICARB. CAPACITOR	2.2nF
C20	CERAMIC CAPACITOR	100pF	C76	ELECTROLYTIC CAPACITOR	
C21	POLICARB. CAPACITOR	2.2nF	C77	ELECTROLYTIC CAPACITOR	
C22	POLICARB. CAPACITOR	2.7nF	C78	POLICARB. CAPACITOR	2.2nF
C23	CERAMIC CAPACITOR	120pF	C79	POLICARB. CAPACITOR	2.2nF
C24	POLICARB. CAPACITOR	3.3nF	C80	POLICARB. CAPACITOR	2.2nF
C25	CERAMIC CAPACITOR	20pF	C81	POLICARB. CAPACITOR	2.2nF
C26	CERAMIC CAPACITOR	100pF	C82	POLICARB. CAPACITOR	47nF
C27	POLICARB. CAPACITOR	2.7nF	C83	ELECTROLITIC CAPACITOR	1 F
C28	ELECTROLYTIC CAPACITOR	220 F	C84	CERAMIC CAPACITOR	10pF
C29	ELECTROLYTIC CAPACITOR	220 F	C85	CERAMIC CAPACITOR	82pF
C30	POLICARB. CAPACITOR	47nF	C86	CERAMIC CAPACITOR	pF
C31	POLICARB. CAPACITOR	3.9nF	C87	CERAMIC CAPACITOR	100pF
C32	POLICARB. CAPACITOR	1.5nF	C88	CERAMIC CAPACITOR	100pF
C33	POLICARB. CAPACITOR	1.8nF		(placed near the SCA1-IN)	
C34	CERAMIC CAPACITOR	100pF	C89	CERAMIC CAPACITOR	100pF
C35	POLICARB. CAPACITOR	2.7nF		(placed near the SCA2-IN)	
C36	POLICARB. CAPACITOR	1.5nF	C90	CERAMIC CAPACITOR	100pF

	(placed near the SCA3-IN)		L3	INDUCTOR	RM6-R
C91	CERAMIC CAPACITOR	100pF	L4	INDUCTOR	RM6-G
	(placed near the IN-R+)		L5	INDUCTOR	RM6-W
C92	CERAMIC CAPACITOR	100pF	L6	INDUCTOR	RM6-R
	(placed near the IN-R-)		L7	INDUCTOR	RM6-G2
C93	CERAMIC CAPACITOR	100pF	L8	INDUCTOR	RM6-P
	(placed near the MPX-IN)		L9	INDUCTOR	1 H
C94	CERAMIC CAPACITOR	100pF	L10	INDUCTOR	1 H
	(placed near the IN-L+)		L11	INDUCTOR	1 H
C95	CERAMIC CAPACITOR	100pF	L12	INDUCTOR	1 H
	(placed near the IN-L-)		L13	INDUCTOR	1 H
D1	DIODE	BAR10	L14	INDUCTOR	1 H
D2	DIODE	1N4148	L15	INDUCTOR	1 H
D3	DIODE	BAR10	L16	INDUCTOR	1 H
D4	DIODE	1N4148	U1	INTEGRATED CIRCUIT	LF353
D5	DIODE	LED	U2	INTEGRATED CIRCUIT	LF353
D5	ZENER DIODE	5.6V	U3	INTEGRATED CIRCUIT	PMI2404
D6	DIODE	1N4148	U4	INTEGRATED CIRCUIT	TL082
D7	DIODE (under U16)	BAV21	U5	INTEGRATED CIRCUIT	74C14
D8	DIODE (under U16)	BAV21	U6	INTEGRATED CIRCUIT	PMI2404
D9	DIODE (under U16)	BAV21	U7	INTEGRATED CIRCUIT	LF353
D10	DIODE (under U16)	BAV21	U8	INTEGRATED CIRCUIT	LF353
D11	DIODE (under U13)	BAV21	U9	INTEGRATED CIRCUIT	
D12	DIODE (under U13)	BAV21	U10	INTEGRATED CIRCUIT	LF353
D13	DIODE (under U7)	BAV21	U11	INTEGRATED CIRCUIT	PMI2404
D14	DIODE (under U7)	BAV21	U12	INTEGRATED CIRCUIT	AC797
D15	DIODE (under U7)	BAV21	U13	INTEGRATED CIRCUIT	LF353
D16	DIODE (under U7)	BAV21	U14	INTEGRATED CIRCUIT	AD797
D17	DIODE (under U12)	BAV21	U15	INTEGRATED CIRCUIT	AD797
D18	DIODE (under U12)	BAV21	U16	INTEGRATED CIRCUIT	LF353
D19	DIODE (under U1)	BAV21	U17	INTEGRATED CIRCUIT	LF353
D20	DIODE (under U1)	BAV21	U18	INTEGRATED CIRCUIT	LF353
D21	DIODE (under U1)	BAV21	U19	INTEGRATED CIRCUIT	LF353
D22	DIODE (under U1)	BAV21	U20	INTEGRATED CIRCUIT	LF353
D23	DIODE (under U15)	BAV21	J1	JUMPER	
D24	DIODE (under U15)	BAV21	J2	JUMPER	
L1	INDUCTOR	RM6-G	J3	JUMPER	
L2	INDUCTOR	RM6-W	J4	JUMPER	

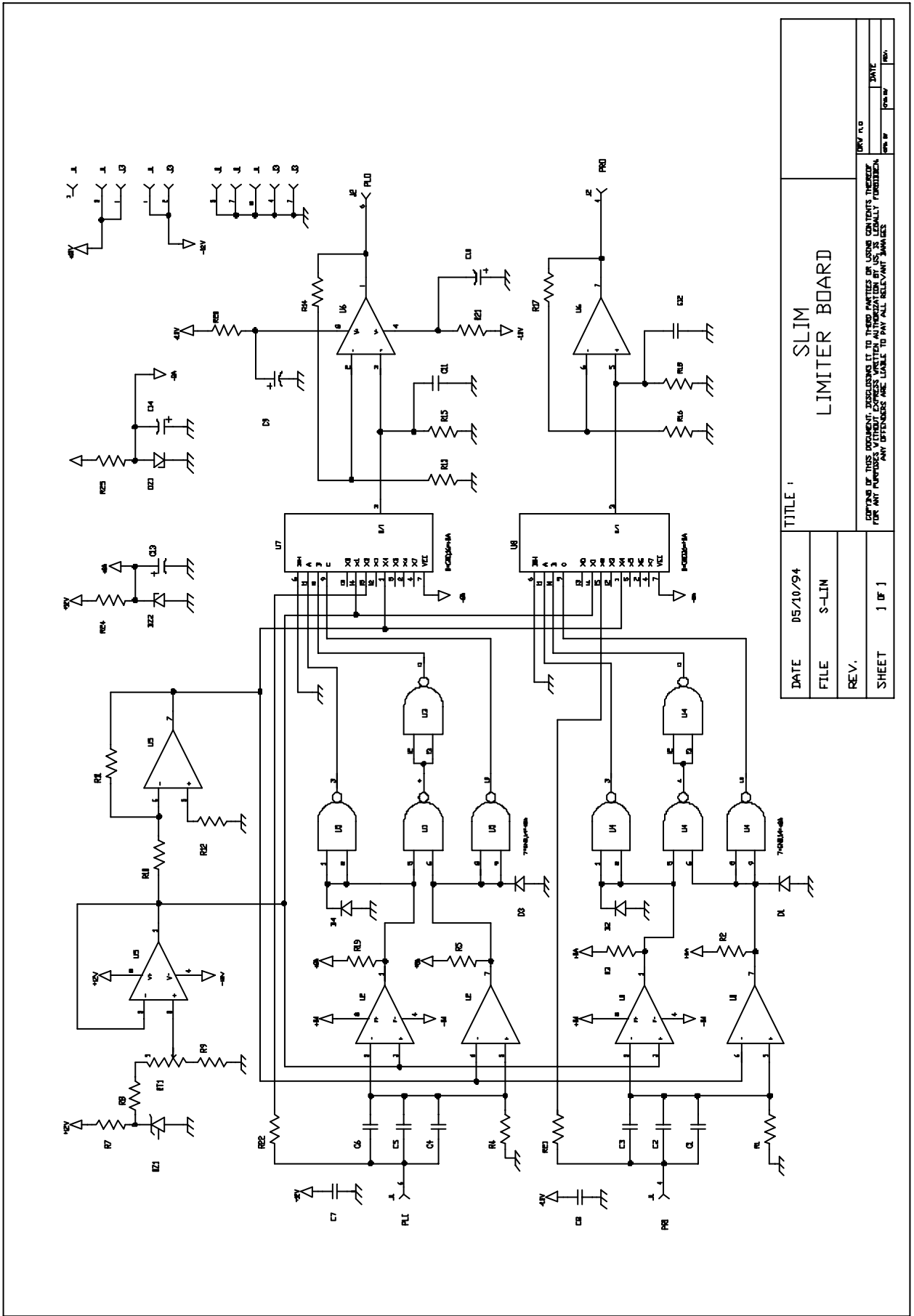

TITLE 1		DATE 05/10/94	REV.	DRW. NO.
SLIM LIMITER BOARD		FILE S-LIN		DATE
				DRW. BY
				NO.

DESIGNER OF THIS DOCUMENT ACCEPTS RESPONSIBILITY FOR THE ACCURACY OF THE INFORMATION CONTAINED HEREIN. ANY USER OF THIS DOCUMENT WITHOUT EXPRESS WRITTEN AUTHORIZATION BY US IS LEGALLY RESPONSIBLE FOR ANY DAMAGES WITHOUT EXPRESS WRITTEN AUTHORIZATION BY US. ANY DEFENDERS ARE LIABLE TO PAY ALL RELEVANT DAMAGES.

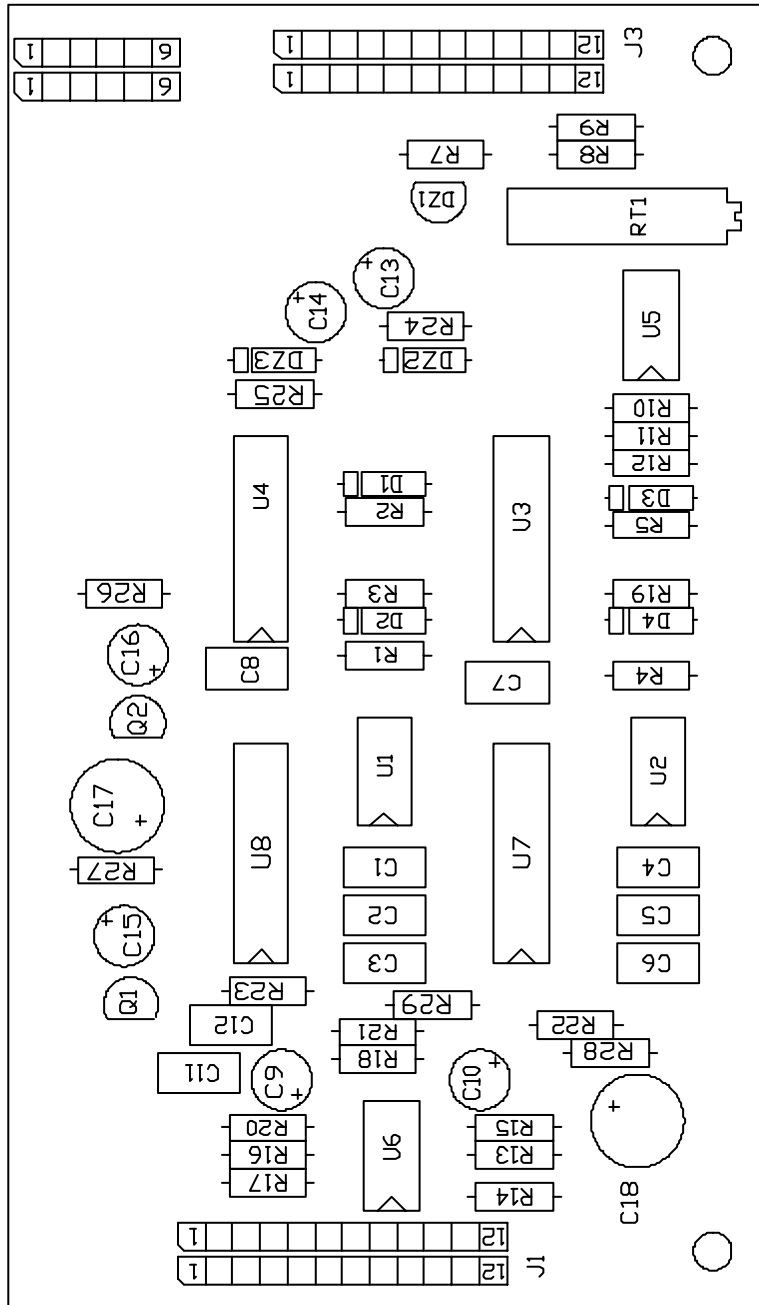

DATE	04/04/96	TITLE	SLIM	L-1 L-2 L-3 L-4 L-5 L-6 L-7 L-8 L-9 L-10 L-11 L-12 L-13 L-14 L-15 L-16 L-17 L-18 L-19 L-20 L-21 L-22 L-23 L-24 L-25 L-26 L-27 L-28 L-29 L-30 L-31 L-32 L-33 L-34 L-35 L-36 L-37 L-38 L-39 L-40 L-41 L-42 L-43 L-44 L-45 L-46 L-47 L-48 L-49 L-50 L-51 L-52 L-53 L-54 L-55 L-56 L-57 L-58 L-59 L-60 L-61 L-62 L-63 L-64 L-65 L-66 L-67 L-68 L-69 L-70 L-71 L-72 L-73 L-74 L-75 L-76 L-77 L-78 L-79 L-80 L-81 L-82 L-83 L-84 L-85 L-86 L-87 L-88 L-89 L-90 L-91 L-92 L-93 L-94 L-95 L-96 L-97 L-98 L-99 L-100 L-101 L-102 L-103 L-104 L-105 L-106 L-107 L-108 L-109 L-110 L-111 L-112 L-113 L-114 L-115 L-116 L-117 L-118 L-119 L-120 L-121 L-122 L-123 L-124 L-125 L-126 L-127 L-128 L-129 L-130 L-131 L-132 L-133 L-134 L-135 L-136 L-137 L-138 L-139 L-140 L-141 L-142 L-143 L-144 L-145 L-146 L-147 L-148 L-149 L-150 L-151 L-152 L-153 L-154 L-155 L-156 L-157 L-158 L-159 L-160 L-161 L-162 L-163 L-164 L-165 L-166 L-167 L-168 L-169 L-170 L-171 L-172 L-173 L-174 L-175 L-176 L-177 L-178 L-179 L-180 L-181 L-182 L-183 L-184 L-185 L-186 L-187 L-188 L-189 L-190 L-191 L-192 L-193 L-194 L-195 L-196 L-197 L-198 L-199 L-200 L-201 L-202 L-203 L-204 L-205 L-206 L-207 L-208 L-209 L-210 L-211 L-212 L-213 L-214 L-215 L-216 L-217 L-218 L-219 L-220 L-221 L-222 L-223 L-224 L-225 L-226 L-227 L-228 L-229 L-230 L-231 L-232 L-233 L-234 L-235 L-236 L-237 L-238 L-239 L-240 L-241 L-242 L-243 L-244 L-245 L-246 L-247 L-248 L-249 L-250 L-251 L-252 L-253 L-254 L-255 L-256 L-257 L-258 L-259 L-260 L-261 L-262 L-263 L-264 L-265 L-266 L-267 L-268 L-269 L-270 L-271 L-272 L-273 L-274 L-275 L-276 L-277 L-278 L-279 L-280 L-281 L-282 L-283 L-284 L-285 L-286 L-287 L-288 L-289 L-290 L-291 L-292 L-293 L-294 L-295 L-296 L-297 L-298 L-299 L-300 L-301 L-302 L-303 L-304 L-305 L-306 L-307 L-308 L-309 L-310 L-311 L-312 L-313 L-314 L-315 L-316 L-317 L-318 L-319 L-320 L-321 L-322 L-323 L-324 L-325 L-326 L-327 L-328 L-329 L-330 L-331 L-332 L-333 L-334 L-335 L-336 L-337 L-338 L-339 L-340 L-341 L-342 L-343 L-344 L-345 L-346 L-347 L-348 L-349 L-350 L-351 L-352 L-353 L-354 L-355 L-356 L-357 L-358 L-359 L-360 L-361 L-362 L-363 L-364 L-365 L-366 L-367 L-368 L-369 L-370 L-371 L-372 L-373 L-374 L-375 L-376 L-377 L-378 L-379 L-380 L-381 L-382 L-383 L-384 L-385 L-386 L-387 L-388 L-389 L-390 L-391 L-392 L-393 L-394 L-395 L-396 L-397 L-398 L-399 L-400 L-401 L-402 L-403 L-404 L-405 L-406 L-407 L-408 L-409 L-410 L-411 L-412 L-413 L-414 L-415 L-416 L-417 L-418 L-419 L-420 L-421 L-422 L-423 L-424 L-425 L-426 L-427 L-428 L-429 L-430 L-431 L-432 L-433 L-434 L-435 L-436 L-437 L-438 L-439 L-440 L-441 L-442 L-443 L-444 L-445 L-446 L-447 L-448 L-449 L-450 L-451 L-452 L-453 L-454 L-455 L-456 L-457 L-458 L-459 L-460 L-461 L-462 L-463 L-464 L-465 L-466 L-467 L-468 L-469 L-470 L-471 L-472 L-473 L-474 L-475 L-476 L-477 L-478 L-479 L-480 L-481 L-482 L-483 L-484 L-485 L-486 L-487 L-488 L-489 L-490 L-491 L-492 L-493 L-494 L-495 L-496 L-497 L-498 L-499 L-500 L-501 L-502 L-503 L-504 L-505 L-506 L-507 L-508 L-509 L-510 L-511 L-512 L-513 L-514 L-515 L-516 L-517 L-518 L-519 L-520 L-521 L-522 L-523 L-524 L-525 L-526 L-527 L-528 L-529 L-530 L-531 L-532 L-533 L-534 L-535 L-536 L-537 L-538 L-539 L-540 L-541 L-542 L-543 L-544 L-545 L-546 L-547 L-548 L-549 L-550 L-551 L-552 L-553 L-554 L-555 L-556 L-557 L-558 L-559 L-560 L-561 L-562 L-563 L-564 L-565 L-566 L-567 L-568 L-569 L-570 L-571 L-572 L-573 L-574 L-575 L-576 L-577 L-578 L-579 L-580 L-581 L-582 L-583 L-584 L-585 L-586 L-587 L-588 L-589 L-590 L-591 L-592 L-593 L-594 L-595 L-596 L-597 L-598 L-599 L-600 L-601 L-602 L-603 L-604 L-605 L-606 L-607 L-608 L-609 L-610 L-611 L-612 L-613 L-614 L-615 L-616 L-617 L-618 L-619 L-620 L-621 L-622 L-623 L-624 L-625 L-626 L-627 L-628 L-629 L-630 L-631 L-632 L-633 L-634 L-635 L-636 L-637 L-638 L-639 L-640 L-641 L-642 L-643 L-644 L-645 L-646 L-647 L-648 L-649 L-650 L-651 L-652 L-653 L-654 L-655 L-656 L-657 L-658 L-659 L-660 L-661 L-662 L-663 L-664 L-665 L-666 L-667 L-668 L-669 L-670 L-671 L-672 L-673 L-674 L-675 L-676 L-677 L-678 L-679 L-680 L-681 L-682 L-683 L-684 L-685 L-686 L-687 L-688 L-689 L-690 L-691 L-692 L-693 L-694 L-695 L-696 L-697 L-698 L-699 L-700 L-701 L-702 L-703 L-704 L-705 L-706 L-707 L-708 L-709 L-710 L-711 L-712 L-713 L-714 L-715 L-716 L-717 L-718 L-719 L-720 L-721 L-722 L-723 L-724 L-725 L-726 L-727 L-728 L-729 L-730 L-731 L-732 L-733 L-734 L-735 L-736 L-737 L-738 L-739 L-740 L-741 L-742 L-743 L-744 L-745 L-746 L-747 L-748 L-749 L-750 L-751 L-752 L-753 L-754 L-755 L-756 L-757 L-758 L-759 L-760 L-761 L-762 L-763 L-764 L-765 L-766 L-767 L-768 L-769 L-770 L-771 L-772 L-773 L-774 L-775 L-776 L-777 L-778 L-779 L-780 L-781 L-782 L-783 L-784 L-785 L-786 L-787 L-788 L-789 L-790 L-791 L-792 L-793 L-794 L-795 L-796 L-797 L-798 L-799 L-800 L-801 L-802 L-803 L-804 L-805 L-806 L-807 L-808 L-809 L-810 L-811 L-812 L-813 L-814 L-815 L-816 L-817 L-818 L-819 L-820 L-821 L-822 L-823 L-824 L-825 L-826 L-827 L-828 L-829 L-830 L-831 L-832 L-833 L-834 L-835 L-836 L-837 L-838 L-839 L-840 L-841 L-842 L-843 L-844 L-845 L-846 L-847 L-848 L-849 L-850 L-851 L-852 L-853 L-854 L-855 L-856 L-857 L-858 L-859 L-860 L-861 L-862 L-863 L-864 L-865 L-866 L-867 L-868 L-869 L-870 L-871 L-872 L-873 L-874 L-875 L-876 L-877 L-878 L-879 L-880 L-881 L-882 L-883 L-884 L-885 L-886 L-887 L-888 L-889 L-890 L-891 L-892 L-893 L-894 L-895 L-896 L-897 L-898 L-899 L-900 L-901 L-902 L-903 L-904 L-905 L-906 L-907 L-908 L-909 L-910 L-911 L-912 L-913 L-914 L-915 L-916 L-917 L-918 L-919 L-920 L-921 L-922 L-923 L-924 L-925 L-926 L-927 L-928 L-929 L-930 L-931 L-932 L-933 L-934 L-935 L-936 L-937 L-938 L-939 L-940 L-941 L-942 L-943 L-944 L-945 L-946 L-947 L-948 L-949 L-950 L-951 L-952 L-953 L-954 L-955 L-956 L-957 L-958 L-959 L-960 L-961 L-962 L-963 L-964 L-965 L-966 L-967 L-968 L-969 L-970 L-971 L-972 L-973 L-974 L-975 L-976 L-977 L-978 L-979 L-980 L-981 L-982 L-983 L-984 L-985 L-986 L-987 L-988 L-989 L-990 L-991 L-992 L-993 L-994 L-995 L-996 L-997 L-998 L-999 L-1000 L-1001 L-1002 L-1003 L-1004 L-1005 L-1006 L-1007 L-1008 L-1009 L-1010 L-1011 L-1012 L-1013 L-1014 L-1015 L-1016 L-1017 L-1018 L-1019 L-1020 L-1021 L-1022 L-1023 L-1024 L-1025 L-1026 L-1027 L-1028 L-1029 L-1030 L-1031 L-1032 L-1033 L-1034 L-1035 L-1036 L-1037 L-1038 L-1039 L-1040 L-1041 L-1042 L-1043 L-1044 L-1045 L-1046 L-1047 L-1048 L-1049 L-1050 L-1051 L-1052 L-1053 L-1054 L-1055 L-1056 L-1057 L-1058 L-1059 L-1060 L-1061 L-1062 L-1063 L-1064 L-1065 L-1066 L-1067 L-1068 L-1069 L-1070 L-1071 L-1072 L-1073 L-1074 L-1075 L-1076 L-1077 L-1078 L-1079 L-1080 L-1081 L-1082 L-1083 L-1084 L-1085 L-1086 L-1087 L-1088 L-1089 L-1090 L-1091 L-1092 L-1093 L-1094 L-1095 L-1096 L-1097 L-1098 L-1099 L-1100 L-1101 L-1102 L-1103 L-1104 L-1105 L-1106 L-1107 L-1108 L-1109 L-1110 L-1111 L-1112 L-1113 L-1114 L-1115 L-1116 L-1117 L-1118 L-1119 L-1120 L-1121 L-1122 L-1123 L-1124 L-1125 L-1126 L-1127 L-1128 L-1129 L-1130 L-1131 L-1132 L-1133 L-1134 L-1135 L-1136 L-1137 L-1138 L-1139 L-1140 L-1141 L-1142 L-1143 L-1144 L-1145 L-1146 L-1147 L-1148 L-1149 L-1150 L-1151 L-1152 L-1153 L-1154 L-1155 L-1156 L-1157 L-1158 L-1159 L-1160 L-1161 L-1162 L-1163 L-1164 L-1165 L-1166 L-1167 L-1168 L-1169 L-1170 L-1171 L-1172 L-1173 L-1174 L-1175 L-1176 L-1177 L-1178 L-1179 L-1180 L-1181 L-1182 L-1183 L-1184 L-1185 L-1186 L-1187 L-1188 L-1189 L-1190 L-1191 L-1192 L-1193 L-1194 L-1195 L-1196 L-1197 L-1198 L-1199 L-1200 L-1201 L-1202 L-1203 L-1204 L-1205 L-1206 L-1207 L-1208 L-1209 L-1210 L-1211 L-1212 L-1213 L-1214 L-1215 L-1216 L-1217 L-1218 L-1219 L-1220 L-1221 L-1222 L-1223 L-1224 L-1225 L-1226 L-1227 L-1228 L-1229 L-1230 L-1231 L-1232 L-1233 L-1234 L-1235 L-1236 L-1237 L-1238 L-1239 L-1240 L-1241 L-1242 L-1243 L-1244 L-1245 L-1246 L-1247 L-1248 L-1249 L-1250 L-1251 L-1252 L-1253 L-1254 L-1255 L-1256 L-1257 L-1258 L-1259 L-1260 L-1261 L-1262 L-1263 L-1264 L-1265 L-1266 L-1267 L-1268 L-1269 L-1270 L-1271 L-1272 L-1273 L-1274 L-1275 L-1276 L-1277 L-1278 L-1279 L-1280 L-1281 L-1282 L-1283 L-1284 L-1285 L-1286 L-1287 L-1288 L-1289 L-1290 L-1291 L-1292 L-1293 L-1294 L-1295 L-1296 L-1297 L-1298 L-1299 L-1300 L-1301 L-1302 L-1303 L-1304 L-1305 L-1306 L-1307 L-1308 L-1309 L-1310 L-1311 L-1312 L-1313 L-1314 L-1315 L-1316 L-13
------	----------	-------	------	---

SLIM BOARD PART LIST

R1	RESISTOR 1% 0.25W	330K	C4	CERAMIC CAPACITOR	2.2 F
R2	RESISTOR 1% 0.25W	1K	C5	CERAMIC CAPACITOR	2.2 F
R3	RESISTOR 1% 0.25W	1K	C6	CERAMIC CAPACITOR	2.2 F
R4	RESISTOR 1% 0.25W	330K	C7	CERAMIC CAPACITOR	100nF
R5	RESISTOR 1% 0.25W	1K	C8	CERAMIC CAPACITOR	100nF
R6	RESISTOR 1% 0.25W	180	C9	ELECTROLYTIC CAPACITOR	10 F
R7	RESISTOR 1% 0.25W	3.3K	C10	ELECTROLYTIC CAPACITOR	10 F
R8	RESISTOR 1% 0.25W	182	C11	POLICARB. CAPACITOR	100nF
R9	RESISTOR 1% 0.25W	1.8K	C12	POLICARB. CAPACITOR	100nF
R10	RESISTOR 1% 0.25W	10K	C13	ELECTROLYTIC CAPACITOR	10 F
R11	RESISTOR 1% 0.25W	10K	C14	ELECTROLYTIC CAPACITOR	10 F
R12	RESISTOR 1% 0.25W	4.7K	C15	ELECTROLYTIC CAPACITOR	47 F
R13			C16	ELECTROLYTIC CAPACITOR	47 F
R14	RESISTOR 1% 0.25W	10K	C17	ELECTROLYTIC CAPACITOR	220 F
R15	RESISTOR 1% 0.25W	10K	C18	ELECTROLYTIC CAPACITOR	220 F
R16			U1	INTEGRATED CIRCUIT	LM393
R17	RESISTOR 1% 0.25W	10K	U2	INTEGRATED CIRCUIT	LM393
R18	RESISTOR 1% 0.25W	10K	U3	INTEGRATED CIRCUIT	4011
R19	RESISTOR 1% 0.25W	1K	U4	INTEGRATED CIRCUIT	4011
R20	RESISTOR 1% 0.25W	100	U5	INTEGRATED CIRCUIT	LM358
R21	RESISTOR 1% 0.25W	1K	U6	INTEGRATED CIRCUIT	LF353
R22	RESISTOR 1% 0.25W	182	U7	INTEGRATED CIRCUIT	4051
R23	RESISTOR 1% 0.25W	182	U8	INTEGRATED CIRCUIT	4051
R24	RESISTOR 1% 0.25W	330	D1	DIODE	1N4148
R25	RESISTOR 1% 0.25W	330	D2	DIODE	1N4148
R26	RESISTOR 1% 0.25W	6.8K	D3	DIODE	1N4148
R27	RESISTOR 1% 0.25W	6.8K	D4	DIODE	1N4148
R28	RESISTOR 1% 0.25W	270	DZ1	ZENER DIODE	LM336/5V
R29	RESISTOR 1% 0.25W	270	DZ2	ZENER DIODE	7.5V
RT1	TRIMMER 10T	10K	DZ3	ZENER DIODE	7.5V
C1	CERAMIC CAPACITOR	2.2 F	J1	STRIP CONNECTOR 6p	
C2	CERAMIC CAPACITOR	2.2 F	J2	STRIP CONNECTOR 12p	
C3	CERAMIC CAPACITOR	2.2 F	J3	STRIP CONNECTOR 12p	

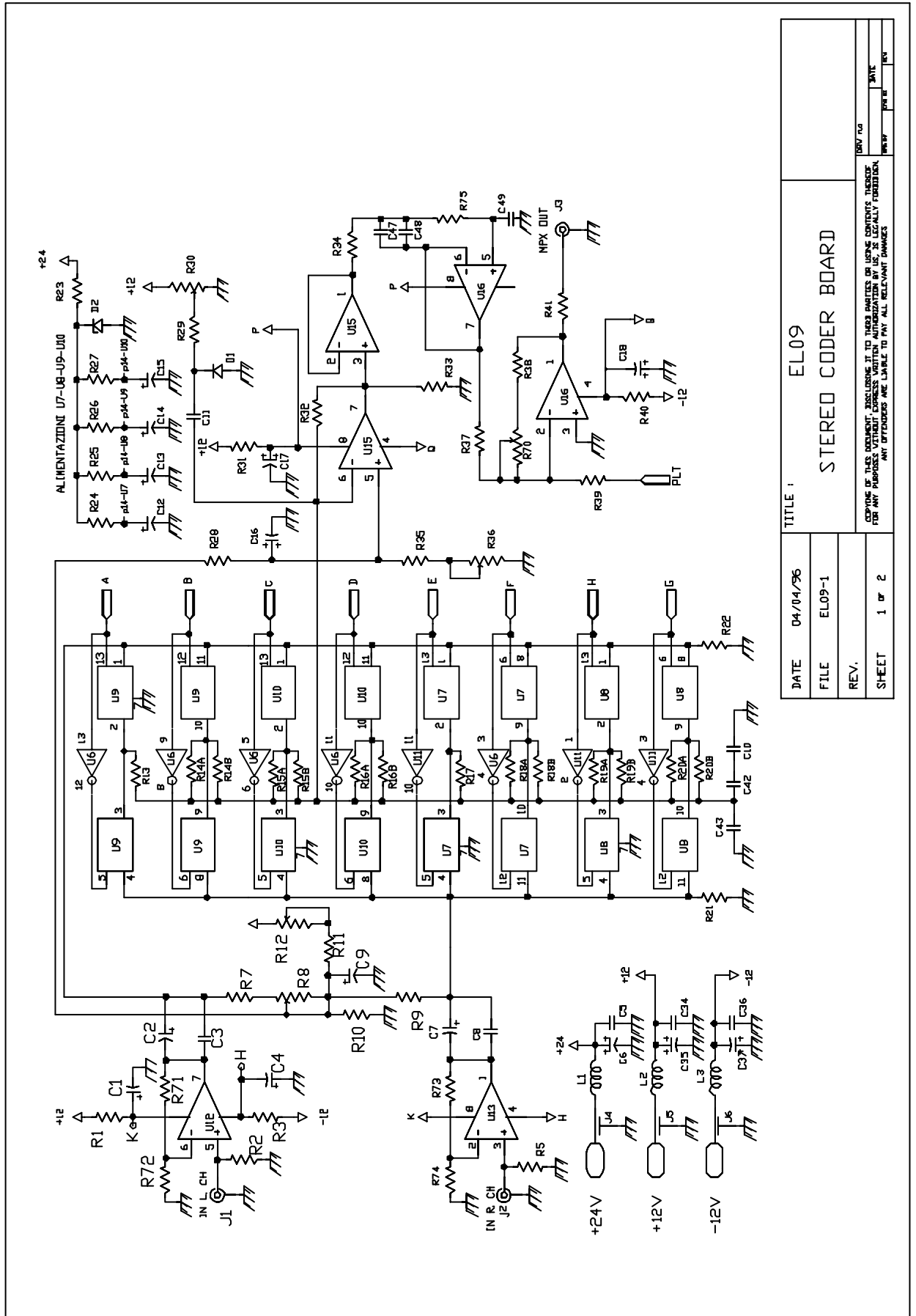

DATE	04/04/96	TITLE	EL09
FILE	EL09-1	STEREO CODER BOARD	
REV.			
SHEET	1 of 2		

COPYING OF THIS DOCUMENT IS PROHIBITED BY FEDERAL STATUTE, 18 USC 793 AND 794. ANY OFFENDERS ARE LIABLE TO PAY ALL RELEVANT DAMAGES.

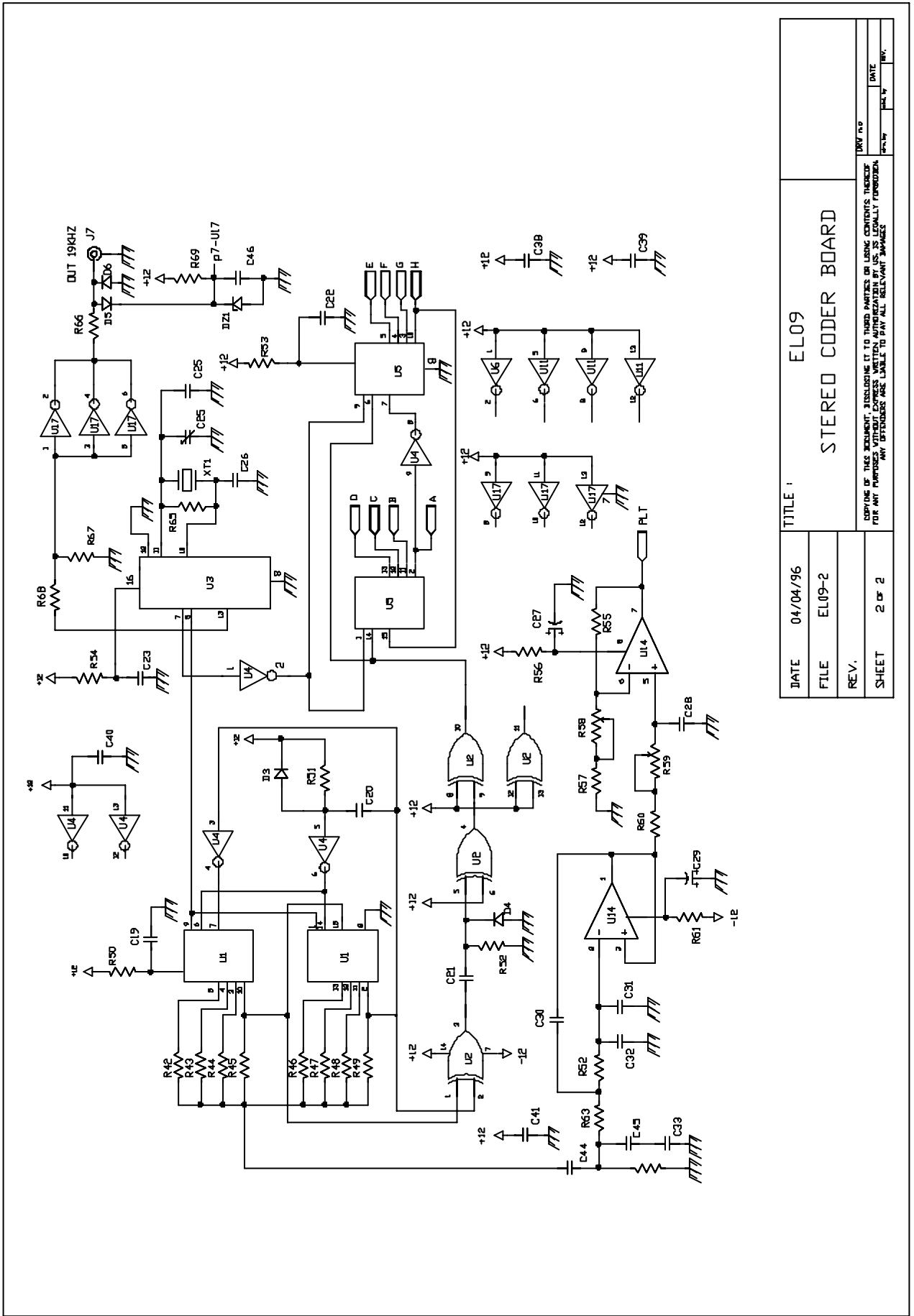

DATE	04/04/96	TITLE	ELO9
FILE	EL09-2	STERED CODER BOARD	
REV.			
SHEET	2 OF 2		

DATE

BY

COPYING OF THIS DOCUMENT, INCLUDING IT TO THIRD PARTIES OR USING CONTENTS THEREOF FOR ANY PURPOSES WITHOUT EXPRESS WRITTEN AUTHORIZATION BY U.S. IS LEGALLY PROHIBITED. ANY OFFENSES ARE LIABLE TO PAY ALL RELEVANT DAMAGES.

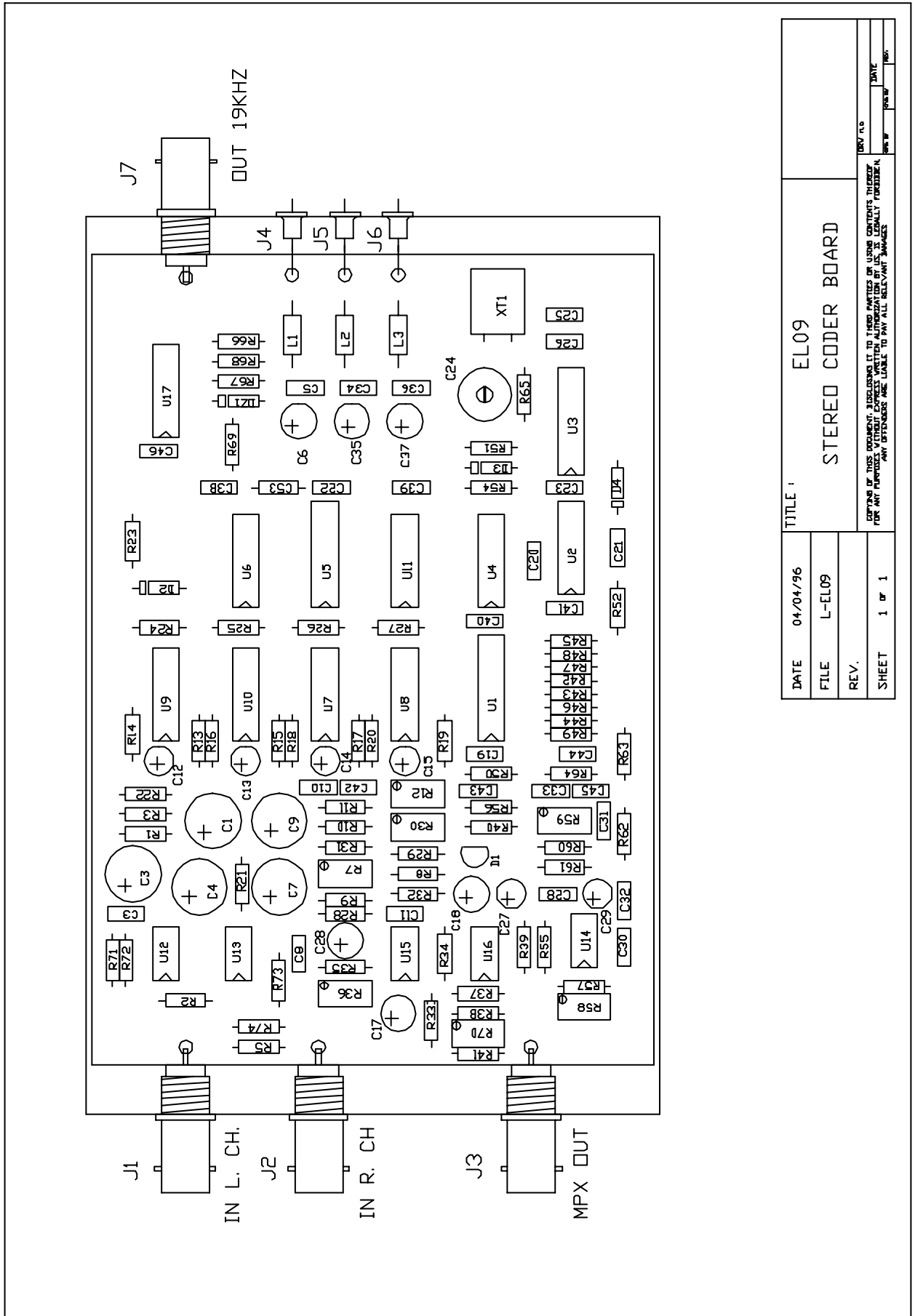

DATE	04/04/96	TITLE	EL09
FILE	L-EL09	STEREO CODER BOARD	
REV.			
SHEET	1 of 1		

COMPANY OF THIS DOCUMENT AGREES TO THE TERMS AND CONDITIONS OF THE MICROFILM EDITIONS OF THIS DOCUMENT. ANY REPRODUCTION OF THIS DOCUMENT WITHOUT EXPRESS WRITTEN AUTHORIZATION OF THE COMPANY IS PROHIBITED. ANY OFFENDERS ARE LIABLE TO PAY ALL RELEVANT DAMAGES.

ELO9 BOARD PART LIST

R1	RESISTOR 1% 0.25W	180	R46	RESISTOR 1% 0.25W	66K
R2	RESISTOR 1% 0.25W	4.7K	R47	RESISTOR 1% 0.25W	75K
R3	RESISTOR 1% 0.25W	180	R58	RESISTOR 1% 0.25W	115K
R4	RESISTOR 1% 0.25W	180	R49	RESISTOR 1% 0.25W	331K
R5	RESISTOR 1% 0.25W	4.7K	R50	RESISTOR 1% 0.25W	100
R6	RESISTOR 1% 0.25W	180	R51	RESISTOR 1% 0.25W	10K
R7	RESISTOR 1% 0.25W	2.2K	R52	RESISTOR 1% 0.25W	33K
R8	TRIMMER 10T	1K	R53	RESISTOR 1% 0.25W	100
R9	RESISTOR 1% 0.25W	2.7K	R54	RESISTOR 1% 0.25W	100
R10	RESISTOR 1% 0.25W	10K	R55	RESISTOR 1% 0.25W	10K
R11	RESISTOR 1% 0.25W	180	R56	RESISTOR 1% 0.25W	180
R12	TRIMMER 10T	50K	R57	RESISTOR 1% 0.25W	2.2K
R13	RESISTOR 1% 0.25W	33.1K	R58	TRIMMER 10T	20K
R14A	RESISTOR 1% 0.25W	11.8K	R59	TRIMMER 10T	2.2K
R14B	RESISTOR 1% 0.25W	1M	R60	RESISTOR 1% 0.25W	560
R15A	RESISTOR 1% 0.25W	8.2K	R61	RESISTOR 1% 0.25W	180
R15B	RESISTOR 1% 0.25W	150K	R62	RESISTOR 1% 0.25W	3.9K
R16A	RESISTOR 1% 0.25W	6.8K	R63	RESISTOR 1% 0.25W	3.9K
R16B	RESISTOR 1% 0.25W	180K	R64	RESISTOR 1% 0.25W	5.6K
R17	RESISTOR 1% 0.25W	33.1K	R65	RESISTOR 1% 0.25W	2.2M
R18A	RESISTOR 1% 0.25W	11.8K	R66	RESISTOR 1% 0.25W	47
R18B	RESISTOR 1% 0.25W	1M	R67	RESISTOR 1% 0.25W	10K
R19A	RESISTOR 1% 0.25W	6.8K	R68	RESISTOR 1% 0.25W	10K
R19B	RESISTOR 1% 0.25W	180K	R79	RESISTOR 1% 0.25W	330
R20A	RESISTOR 1% 0.25W	8.2K	R70	TRIMMER 10T	10K
R20B	RESISTOR 1% 0.25W	150K	R71	RESISTOR 1% 0.25W	3.3K
R21	RESISTOR 1% 0.25W	1M	R72	RESISTOR 1% 0.25W	12K
R22	RESISTOR 1% 0.25W	1M	R73	RESISTOR 1% 0.25W	3.3K
R23	RESISTOR 1% 0.25W	470	R74	RESISTOR 1% 0.25W	12K
R24	RESISTOR 1% 0.25W	180	R75	RESISTOR 1% 0.25W	1.3K
R25	RESISTOR 1% 0.25W	180	C1	ELECTROLYTIC CAPACITOR	220 F
R26	RESISTOR 1% 0.25W	180	C2	ELECTROLYTIC CAPACITOR	220 F
R27	RESISTOR 1% 0.25W	180	C3	CERAMIC CAPACITOR	120pF
R28	RESISTOR 1% 0.25W	47K	C4	ELECTROLYTIC CAPACITOR	220 F
R29	RESISTOR 1% 0.25W	82K	C5	CERAMIC CAPACITOR	100nF
R30	TRIMMER 10T	10K	C6	ELECTROLYTIC CAPACITOR	10 F
R31	RESISTOR 1% 0.25W	180	C7	ELECTROLYTIC CAPACITOR	220 F
R32	RESISTOR 1% 0.25W	1K2	C8	CERAMIC CAPACITOR	120pF
R33	RESISTOR 1% 0.25W	15K	C9	ELECTROLYTIC CAPACITOR	220 F
R34	RESISTOR 1% 0.25W	6.8K	C10	ELECTROLYTIC CAPACITOR	220 F
R35	RESISTOR 1% 0.25W	15K	C11	CERAMIC CAPACITOR	100nF
R36	TRIMMER 10T	10K	C12	ELECTROLYTIC CAPACITOR	47 F
R37	RESISTOR 1% 0.25W	10K	C13	ELECTROLYTIC CAPACITOR	47 F
R38	RESISTOR 1% 0.25W	1K	C14	ELECTROLYTIC CAPACITOR	47 F
R39	RESISTOR 1% 0.25W	150K	C15	ELECTROLYTIC CAPACITOR	47 F
R40	RESISTOR 1% 0.25W	560	C16	ELECTROLYTIC CAPACITOR	47 F
R41	RESISTOR 1% 0.25W	47	C17	ELECTROLYTIC CAPACITOR	47 F
R42	RESISTOR 1% 0.25W	331K	C18	ELECTROLYTIC CAPACITOR	47 F
R43	RESISTOR 1% 0.25W	115K	C19	CERAMIC CAPACITOR	100n
R44	RESISTOR 1% 0.25W	75K	C20	CERAMIC CAPACITOR	33pF
R45	RESISTOR 1% 0.25W	66K	C21	CERAMIC CAPACITOR	33pF

C22	CERAMIC CAPACITOR	100nF	U5	INTEGRATED CIRCUIT	4015
C23	CERAMIC CAPACITOR	100nF	U6	INTEGRATED CIRCUIT	4069
C24	VARIABLE CAPACITOR	25pF	U7	INTEGRATED CIRCUIT	4016
C25	CERAMIC CAPACITOR	22pF	U8	INTEGRATED CIRCUIT	4016
C26	CERAMIC CAPACITOR	100pF	U9	INTEGRATED CIRCUIT	4016
C27	ELECTROLYTIC CAPACITOR	10 F	U10	INTEGRATED CIRCUIT	4016
C28	POLICARB. CAPACITOR	1.8nF	U11	INTEGRATED CIRCUIT	4069
C29	ELECTROLYTIC CAPACITOR	10 F	U12	INTEGRATED CIRCUIT	NE5532
C30	POLICARB. CAPACITOR	1.2nF	U13	INTEGRATED CIRCUIT	NE5532
C31	CERAMIC CAPACITOR	150pF	U14	INTEGRATED CIRCUIT	LF353
C32	CERAMIC CAPACITOR	150pF	U15	INTEGRATED CIRCUIT	LF353
C33	POLICARB. CAPACITOR	1nF	U16	INTEGRATED CIRCUIT	LF353
C34	CERAMIC CAPACITOR	100nF	U17	INTEGRATED CIRCUIT	74C14
C35	ELECTROLYTIC CAPACITOR	10 F	D1	VARICAP	MV115
C36	CERAMIC CAPACITOR	100nF	D2	ZENER DIODE	15V
C37	ELECTROLYTIC CAPACITOR	10 F	D3	DIODE	1N4148
C38	CERAMIC CAPACITOR	100nF	D4	DIODE	1N4148
C39	CERAMIC CAPACITOR	100nF	D5	DIODE (under U17)	BAV21
C40	CERAMIC CAPACITOR	100nF	D6	DIODE (under U17)	BAV21
C41	CERAMIC CAPACITOR	100nF	DZ1	ZENER DIODE	5.1V
C42	POLICARB. CAPACITOR	3.3nF	L1	INDUCTOR	2.2 H
C43	POLICARB. CAPACITOR	2.7nF	L2	INDUCTOR	2.2 H
C44	CERAMIC CAPACITOR	100nF	L3	INDUCTOR	2.2 H
C45	POLICARB. CAPACITOR	1nF	XT1	CRYSTAL QUARTZ KWG	9,728KHz
C46	CERAMIC CAPACITOR	100n	J1	BNC CONNECTOR	
C47	CERAMIC CAPACITOR	120p	J2	BNC CONNECTOR	
C48	CERAMIC CAPACITOR	150p	J3	BNC CONNECTOR	
C49	CERAMIC CAPACITOR	100p	J4	FT CAPACITOR	1000pF
U1	INTEGRATED CIRCUIT	4015	J5	FT CAPACITOR	1000pF
U2	INTEGRATED CIRCUIT	4070	J6	FT CAPACITOR	1000pF
U3	INTEGRATED CIRCUIT	4060	J7	BNC CONNECTOR	
U4	INTEGRATED CIRCUIT	4070			

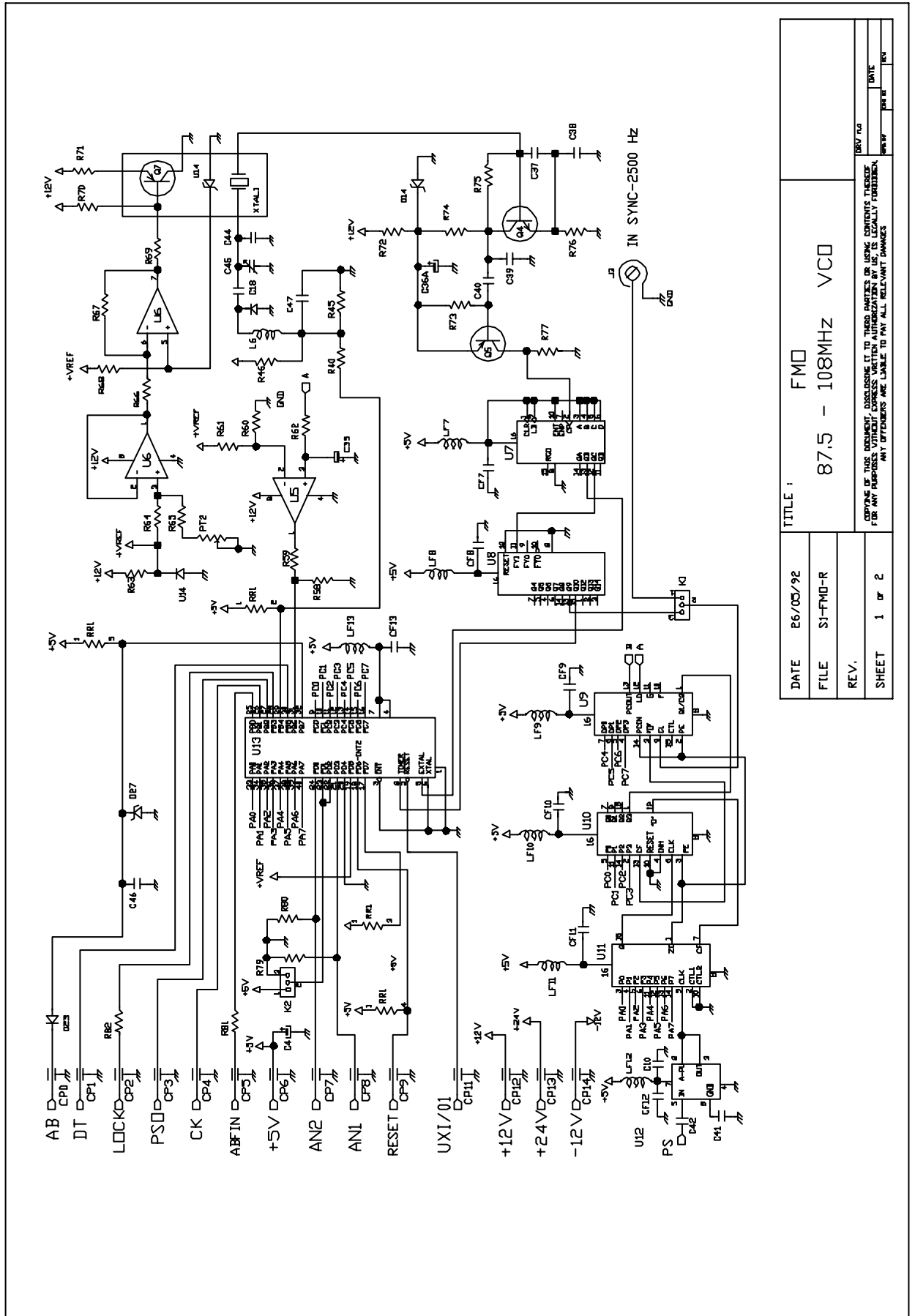

DATE	E6/05/92	TITLE 1	FMD
FILE	SI-FMD-R	87.5 - 108MHZ VCO	
REV.			
SHEET	1 of 2		

COMPANY OF THIS DOCUMENT, UNLESS ASSESS IT TO THEIR SERVICES, IS UNDER NO OBLIGATION TO PROVIDE SUPPORT OR ASSISTANCE IN ANY MANNER. ANY OFFENDERS ARE LIABLE TO PAY ALL RELEVANT DAMAGES.

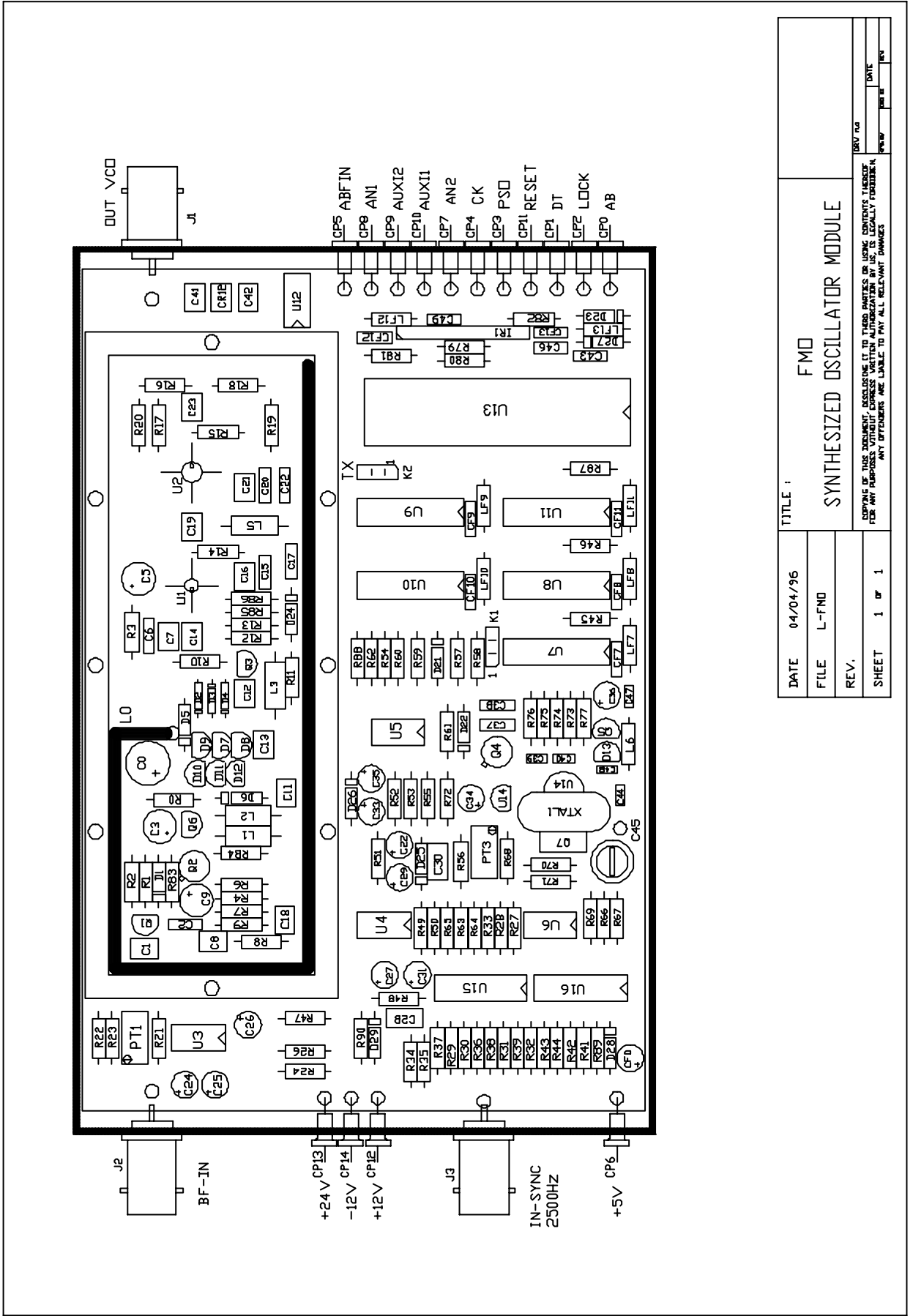

DATE	04/04/96	TITLE	FMD
FILE	L-FMD	SYNTHESIZED OSCILLATOR MODULE	
REV.			
SHEET	1 of 1		

SUPPLIER OF THIS SERVICE, UNDER THE ITT TRADE NAME, IS UNDER CONTRACT TO THE U.S. GOVERNMENT. ANY OFFENSES OR VIOLATIONS OF THE EXPORT ADMINISTRATION ACT OR THE EAR REGULATIONS WILL BE PROSECUTED TO THE FULL EXTENT OF THE LAW. ANY OFFENSES ARE LIABLE TO PAY ALL RELEVANT DAMAGES.

FMO MODULE PART LIST

R0	RESISTOR 1% 0.25W	330	R45	====	
R1	RESISTOR 1% 0.25W	5.6K	R46	====	
R2	RESISTOR 1% 0.25W	180	R47	RESISTOR 1% 0.25W	330
R3	RESISTOR 1% 0.25W	1K	R48	RESISTOR 1% 0.25W	18K
R4	RESISTOR 1% 0.25W	330	R49	RESISTOR 1% 0.25W	18K
R5	RESISTOR 1% 0.25W	390	R50	RESISTOR 1% 0.25W	820
R6	RESISTOR 1% 0.25W	2.7K	R51	RESISTOR 1% 0.25W	18K
R7	RESISTOR 1% 0.25W	10K	R52	RESISTOR 1% 0.25W	18K
R8	RESISTOR 1% 0.25W	1.5K	R53	RESISTOR 1% 0.25W	68K
R9	RESISTOR 1% 0.25W	470	R54	RESISTOR 1% 0.25W	220K
R10	RESISTOR 1% 0.25W	100K	R55	RESISTOR 1% 0.25W	220K
R11	RESISTOR 1% 0.25W	270	R56	RESISTOR 1% 0.25W	18K
R12	RESISTOR 1% 0.25W	120	R57	RESISTOR 1% 0.25W	330K
R13	RESISTOR 1% 0.25W	270	R58	RESISTOR 1% 0.25W	10K
R14	RESISTOR 1% 0.25W	100	R59	RESISTOR 1% 0.25W	18K
R15	RESISTOR 1% 0.25W	100	R60	RESISTOR 1% 0.25W	10K
	INDUCTOR (for RX/FM		R61	RESISTOR 1% 0.25W	10K
	and option /N	6.8 H	R62	RESISTOR 1% 0.25W	330K
R16	RESISTOR 1% 0.25W	15	R63	RESISTOR 1% 0.25W	1K
	RESISTOR 1% 0.25W		R64	RESISTOR 1% 0.25W	10K
	(for RX/FM/option N)	0	R65	RESISTOR 1% 0.25W	8.2K
R17	RESISTOR 1% 0.25W	1.2K	R66	RESISTOR 1% 0.25W	4.7K
	Not inserted for RX/FM/option N		R67	RESISTOR 5% 0.25W	1M
R18	RESISTOR 1% 0.25W	470	R68	RESISTOR 1% 0.25W	3.3K
R19	RESISTOR 1% 0.25W	180	R69	RESISTOR 1% 0.25W	10K
R20	RESISTOR 1% 0.25W	330	R70	RESISTOR 1% 0.25W	4.7K
	Not inserted for RX/FM/option N		R71	RESISTOR 1% 0.25W	15
R21	RESISTOR 1% 0.25W	10K	R72	RESISTOR 1% 0.25W	180
R22	RESISTOR 1% 0.25W	4.7K	R73	RESISTOR 1% 0.25W	10K
R23	RESISTOR 1% 0.25W	8.2K	R74	RESISTOR 1% 0.25W	330
R24	RESISTOR 1% 0.25W	470	R75	RESISTOR 1% 0.25W	56K
R25	RESISTOR 1% 0.25W	330	R76	RESISTOR 1% 0.25W	150
R25	RESISTOR 1% 0.25W	470	R77	RESISTOR 1% 0.25W	150
R27	RESISTOR 1% 0.25W	6.8K	R78	RESISTOR 1% 0.25W	====
R28	RESISTOR 1% 0.25W	2.7K	R78	RESISTOR 1% 0.25W	10K
R29	RESISTOR 1% 0.25W	820	R80	RESISTOR 1% 0.25W	10K
R30	RESISTOR 1% 0.25W	470	R81	RESISTOR 1% 0.25W	1K
R31	RESISTOR 1% 0.25W	2.7K	R82	RESISTOR 1% 0.25W	1K
R32	RESISTOR 1% 0.25W	10K	R83	RESISTOR 1% 0.25W	470
R33	RESISTOR 1% 0.25W	1.8M	IR1	INTEGRATED RESISTOR	10K
R34	RESISTOR 1% 0.25W	10K	PT1	TRIMMER 20T	20K
R35	RESISTOR 1% 0.25W	1.8M	PT2	TRIMMER 20T	10K
R36	RESISTOR 1% 0.25W	10K	C0	ELECTROLYTIC CAPACITOR	220 F
R37	RESISTOR 1% 0.25W	1.8M	C1	CERAMIC CHIP CAPACITOR	1nF
R38	RESISTOR 1% 0.25W	10K	C2	CERAMIC CAPACITOR	100nF
R39	RESISTOR 1% 0.25W	1.8M	C3	ELECTROLYTIC CAPACITOR	10 F
R40		====	C4	ELECTROLYTIC CAPACITOR	47 F
R41	RESISTOR 1% 0.25W	47K	C5	ELECTROLYTIC CAPACITOR	47 F
R42	RESISTOR 1% 0.25W	39K	C6	CERAMIC CAPACITOR	100nF
R43	RESISTOR 1% 0.25W	33K	C7	CERAMIC CHIP CAPACITOR	1nF
R44	RESISTOR 1% 0.25W	82K	C8	CERAMIC CHIP CAPACITOR	1nF

C9	ELECTROLYTIC CAPACITOR	22 F	LF10	INDUCTOR	8.2 H
C10	=====	=====	LF11	INDUCTOR	8.2 H
C11	CERAMIC CHIP CAPACITOR	1nF	LF12	INDUCTOR	8.2 H
C12	CERAMIC CAPACITOR	33pF	LF13	INDUCTOR	8.2 H
C13	CERAMIC CAPACITOR	68pF	D1	DIODE	1N4001
C14	CERAMIC CHIP CAPACITOR	1nF	D2	DIODE	1SS
C15	CERAMIC CAPACITOR	100nF	D3	DIODE	1SS
C16	CERAMIC CHIP CAPACITOR	1nF	D4	DIODE	1SS
C17	CERAMIC CHIP CAPACITOR	1nF	D5	DIODE	BB505
C18	=====	=====	D6	DIODE	BB505
C19	CERAMIC CHIP CAPACITOR	1nF	D7	DIODE	MV209
C20	CERAMIC CAPACITOR	100nF	D8	DIODE	MV209
C21	CERAMIC CHIP CAPACITOR	1nF	D9	DIODE	MV209
C22	CERAMIC CAPACITOR	100nF	D10	DIODE	MV209
C23	CERAMIC CHIP CAPACITOR	1nF	D11	DIODE	MV209
C24	ELECTROLYTIC CAPACITOR	22 F	D12	DIODE	MV209
C25	ELECTROLYTIC CAPACITOR	22 F	D13	DIODE	1N4148
C26	ELECTROLYTIC CAPACITOR	47 F	D14	ZENER DIODE	10V
C27	ELECTROLYTIC CAPACITOR	0.47 F	D15	DIODE	1N4148
C28	CERAMIC CAPACITOR	1 F	D16	ZENER DIODE	9.1V
C29	ELECTROLYTIC CAPACITOR	0.47 F	D17	DIODE	1N4148
C30	CERAMIC CAPACITOR	1 F	D18	DIODE	1N4148
C31	ELECTROLYTIC CAPACITOR	47 F	D19	ZENER DIODE	5V
C32	ELECTROLYTIC CAPACITOR	47 F	D20	ZENER DIODE	6.8V
C33	ELECTROLYTIC CAPACITOR	47 F	D21	ZENER DIODE	6.8v
C34	ELECTROLYTIC CAPACITOR	22 F	D22	REFERENCE I.C.	LM336/5V
C35	ELECTROLYTIC CAPACITOR	22 F	Q1	TRANSISTOR	BC183
C36	ELECTROLYTIC CAPACITOR	22 F	Q2	TRANSISTOR	BCY59
C37	CERAMIC CAPACITOR	150pF	Q3	FET	BF247
C38	CERAMIC CAPACITOR	150pF	Q4	TRANSISTOR	2N2369
C39	CERAMIC CAPACITOR	27pF	Q5	TRANSISTOR	BC557
C40	CERAMIC CAPACITOR	47pF	Q6	FET	BF247
C41	CERAMIC CHIP CAPACITOR	1nF	Q7	DARLINGTON	TIP127
C42	CERAMIC CHIP CAPACITOR	1nF	U1	MODULE	MAR6
C42	=====	=====	U2	MODULE	MAV11
C44	CERAMIC CAPACITOR	33pF	U3	INTEGRATED CIRCUIT	TL082
C45	VARIABLE CAPACITOR	14pF	U4	INTEGRATED CIRCUIT	TL082
C46	CERAMIC CAPACITOR	1 F	U5	INTEGRATED CIRCUIT	TL082
C47	=====	=====	U6	INTEGRATED CIRCUIT	LM358
CF7	CERAMIC CAPACITOR	100nF	U7	INTEGRATED CIRCUIT	74HC160
CF8	CERAMIC CAPACITOR	100nF	U8	INTEGRATED CIRCUIT	4060
CF9	CERAMIC CAPACITOR	100nF	U9	INTEGRATED CIRCUIT	4568
CF10	CERAMIC CAPACITOR	100nF	U10	INTEGRATED CIRCUIT	4526
CF11	CERAMIC CAPACITOR	100nF	U121	INTEGRATED CIRCUIT	4569
CF12	CERAMIC CAPACITOR	100nF	U12	INTEGRATED CIRCUIT	MC12023
CF13	CERAMIC CAPACITOR	100nF	U13	SINGLE-CHIP P	MC68705R5S
L1	INDUCTOR	40T Coil	U14	INTEGRATED CIRCUIT	LM335
L2	INDUCTOR	40T Coil	U15	INTEGRATED CIRCUIT	LM324
L3	INDUCTOR	40T Coil	U16	INTEGRATED CIRCUIT	CD4066
L4	INDUCTOR	6.8 H	CP1	FT CAPACITOR	1000pF
L5	INDUCTOR	6.8 H	CP2	FT CAPACITOR	1000pF
	RESISTOR 1% 0.25W		CP3	FT CAPACITOR	1000pF
	(for RX/FM/option N)	100	CP4	FT CAPACITOR	1000pF
LF7	INDUCTOR	8.2 H	CP5	FT CAPACITOR	1000pF
LF8	INDUCTOR	8.2 H	CP6	FT CAPACITOR	1000pF
LF9	INDUCTOR	8.2 H	CP7	FT CAPACITOR	1000pF

CP8	FT CAPACITOR	1000pF	J1	BNC CONNECTOR	
CP9	FT CAPACITOR	1000pF	J2	BNC CONNECTOR	
CP10	FT CAPACITOR	1000pF	J3	BNC CONNECTOR	
CP11	FT CAPACITOR	1000pF	XTAL1	XTAL	12.800MHz
CP12	FT CAPACITOR	1000pF	K1	JUMPER	
CP13	FT CAPACITOR	1000pF	K2	JUMPER	
CP14	FT CAPACITOR	1000pF			

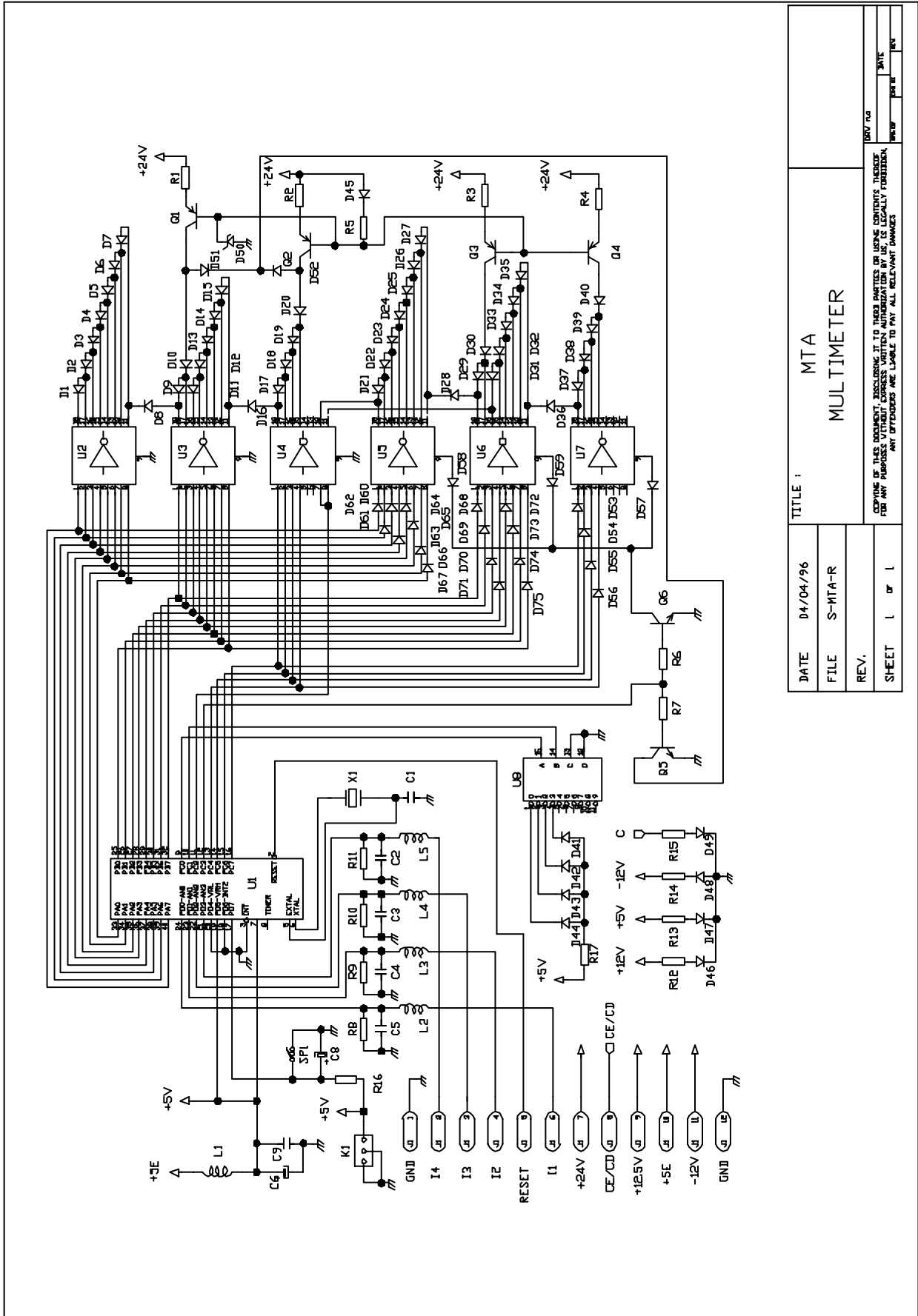

DATE	04/04/96	TITLE	MTA
FILE	S-MTA-R		MULTIMETER
REV.			
SHEET	1	OF	1

REPRODUCTION OF THIS DOCUMENT, INCLUDING IT TO OTHER PARTS OR WORKS, WITHOUT THE WRITTEN AUTHORIZATION OF THE AUTHOR, IS STRICTLY PROHIBITED. ANY OFFENDERS ARE LIABLE TO PAY ALL RELEVANT DAMAGES.

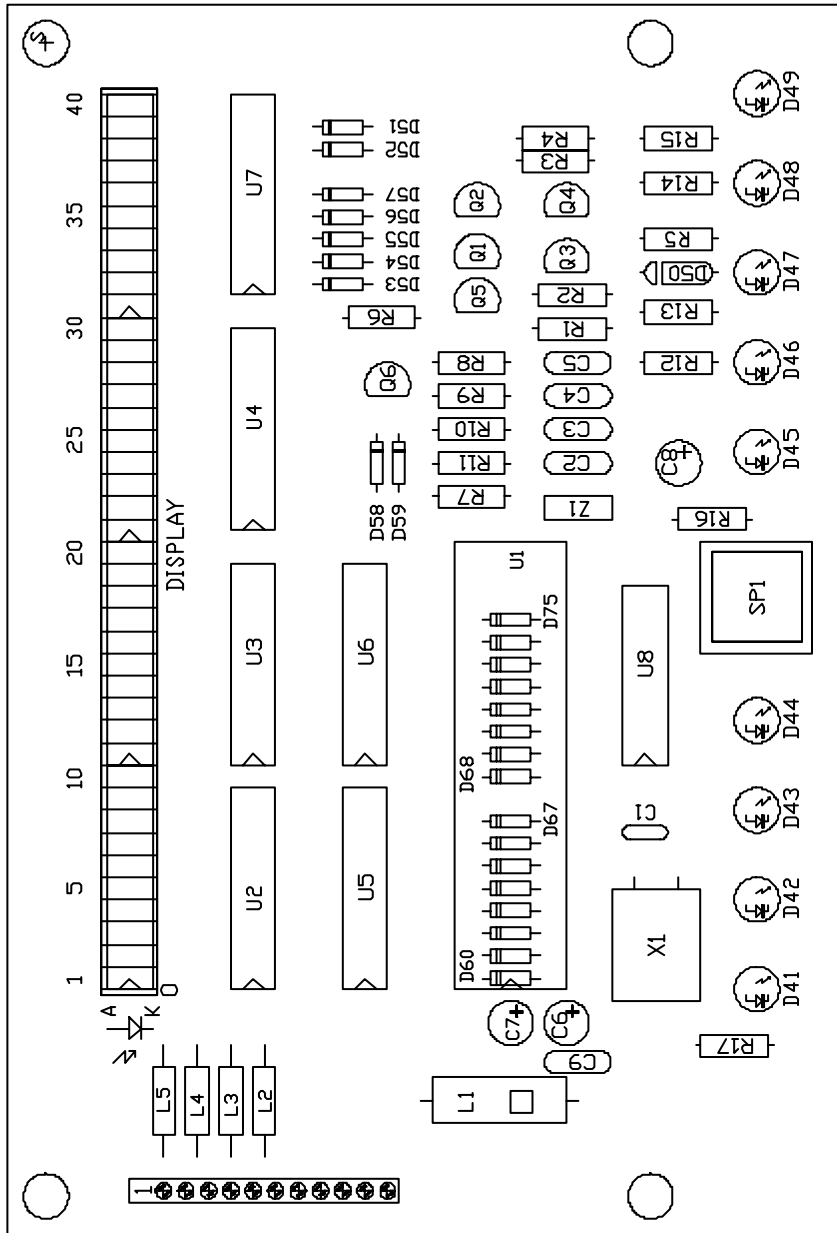

DATE	04/04/96	TITLE	MTA
FILE	S-MTA	MULTIMETER	
REV.			
SHEET	1 OF 1		

COMPANY OF THIS DRAWING RESERVING IT TO MAKE CHANGES OR USING COMPONENTS WITHOUT EXPRESS WRITTEN AUTHORIZATION BY US IS LEGALLY PROHIBITED.
 ANY VIOLATIONS ARE LIABLE TO PAY ALL RELEVANT DAMAGES.

MTA BOARD PART LIST

R1	RESISTOR 1% 0.25W	560	D55	DIODE	1N4148
R2	RESISTOR 1% 0.25W	560	D56	DIODE	1N4148
R3	RESISTOR 1% 0.25W	560	D57	DIODE	1N4148
R4	RESISTOR 1% 0.25W	560	D58	DIODE	1N4148
R5	RESISTOR 1% 0.25W	390	D59	DIODE	1N4148
R6	RESISTOR 1% 0.25W	8.2K	D60	DIODE	1N4148
R7	RESISTOR 1% 0.25W	8.2	D61	DIODE	1N4148
R8	RESISTOR 1% 0.25W	10K	D62	DIODE	1N4148
R9	RESISTOR 1% 0.25W	10K	D63	DIODE	1N4148
R10	RESISTOR 1% 0.25W	10K	D64	DIODE	1N4148
R11	RESISTOR 1% 0.25W	10K	D65	DIODE	1N4148
R12	RESISTOR 1% 0.25W	1.5K	D66	DIODE	1N4148
R13	RESISTOR 1% 0.25W	330	D67	DIODE	1N4148
R14	RESISTOR 1% 0.25W	1.5	D68	DIODE	1N4148
R15	RESISTOR 1% 0.25W	330	D69	DIODE	1N4148
R16	RESISTOR 1% 0.25W	33K	D70	DIODE	1N4148
R17	RESISTOR 1% 0.25W	330	D71	DIODE	1N4148
C1	CERAMIC CAPACITOR	33pF	D72	DIODE	1N4148
C2	ELECTROLYTIC CAP.	10 F-35V	D73	DIODE	1N4148
C3	ELECTROLYTIC CAP.	10 F-35V	D74	DIODE	1N4148
C4	ELECTROLYTIC CAP.	10 F-35V	D75	DIODE	1N4148
C5	ELECTROLYTIC CAP.	10 F-35V	Q1	TRANSISTOR	BC557
C6	ELECTROLYTIC CAP.	4.7 F-35V	Q2	TRANSISTOR	BC557
C7	ELECTROLYTIC CAP.	4.7 F-35V	Q3	TRANSISTOR	BC557
C8	ELECTROLYTIC CAP.	4.7 F-35V	Q4	TRANSISTOR	BC557
C9	CERAMIC CAPACITOR	0,1 F	Q5	TRANSISTOR	BC183
D1 D10	BAR-LED	MV57164	Q6	TRANSISTOR	BC183
D11 D20	BAR-LED	MV57164	U1	SINGLE-CHIP P 68705	
D21 D30	BAR-LED	MV57164	U2	INTEGRATED CIRCUIT	ULN2803
D31 D40	BAR-LED	MV57164	U3	INTEGRATED CIRCUIT	ULN2803
D41	LED DIODE		U4	INTEGRATED CIRCUIT	ULN2803
D42	LED DIODE		U5	INTEGRATED CIRCUIT	ULN2803
D43	LED DIODE		U6	INTEGRATED CIRCUIT	ULN2803
D44	LED DIODE		U7	INTEGRATED CIRCUIT	ULN2803
D45	LED DIODE		U	INTEGRATED CIRCUIT	74C42
D46	LED DIODE		L1	INDUCTOR 8	.2 H
D47	LED DIODE		L2	INDUCTOR 8	.2 H
D48	LED DIODE		L3	INDUCTOR 8	.2 H
D49	LED DIODE		L4	INDUCTOR 8	.2 H
D50	ZENER DIODE 1W	20V	L5	INDUCTOR 8	.2 H
D51	DIODE	1N4148	X1	CRYSTAL QUARTZ	4194KHz
D52	DIODE	1N4148	Z1	JUMPER	
D53	DIODE	1N4148	J1	12 PIN SHF CONNECTOR	
D54	DIODE	1N4148	SP1	PUSH BUTTON	

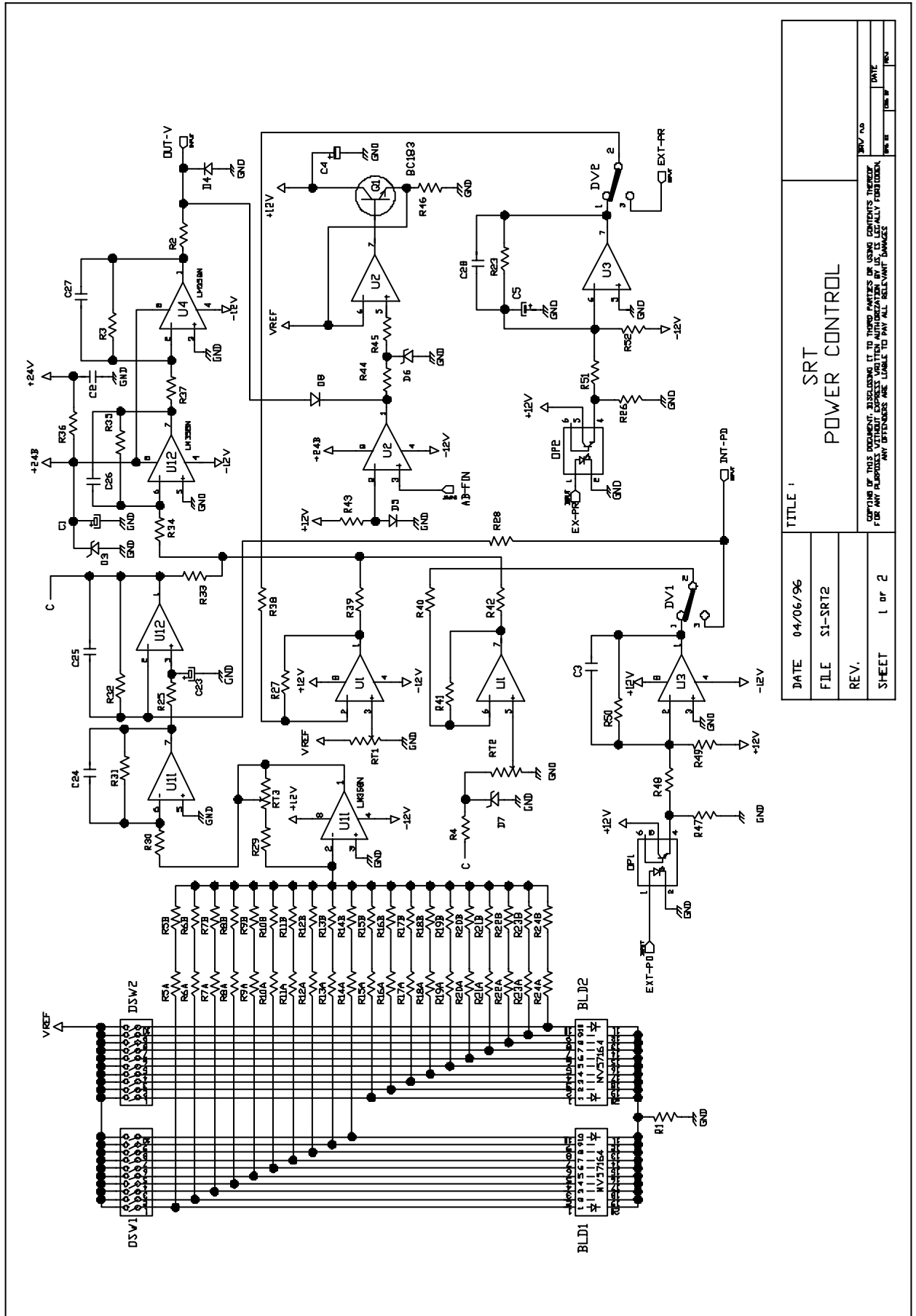

DATE	04/06/96	TITLE 1	SRT POWER CONTROL	REV. NO	
FILE	S1-SRT2			DATE	
REV.				REV. NO	
SHEET	1 OF 2			DATE	

CONFIRM OF THIS DOCUMENT, INCLUDING IT TO THIRD PARTIES OR USING CONTENTS THEREOF
 FOR ANY PURPOSES WITHOUT EXPRESS WRITTEN AUTHORIZATION BY US, IS LEGALLY FORBIDDEN.
 ANY VIOLATIONS ARE LIABLE TO PAY ALL RELEVANT DAMAGES.

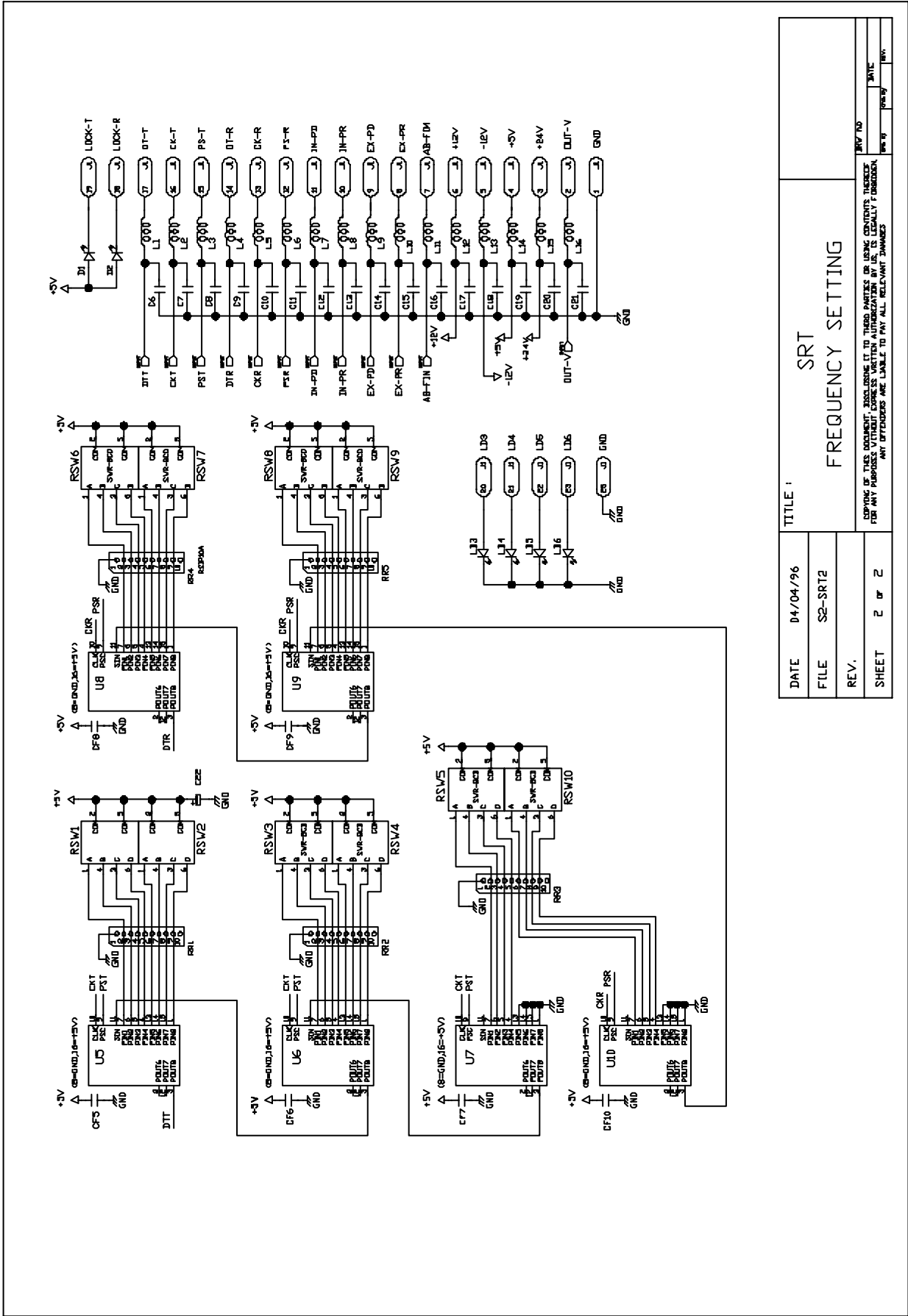

DATE	04/04/96	TITLE	SRT
FILE	S2-SRT2	FREQUENCY SETTING	
REV.			
SHEET	2 OF 2		

COPIING OF THIS DOCUMENT, INCLUDING IT TO THIRD PARTIES OR USING CONTENTS THEREOF, FOR ANY PURPOSES WITHOUT EXPRESS WRITTEN AUTHORIZATION BY US, IS LEGALLY PROHIBITED. ANY OFFENDERS ARE LIABLE TO PAY ALL RELEVANT DAMAGES.

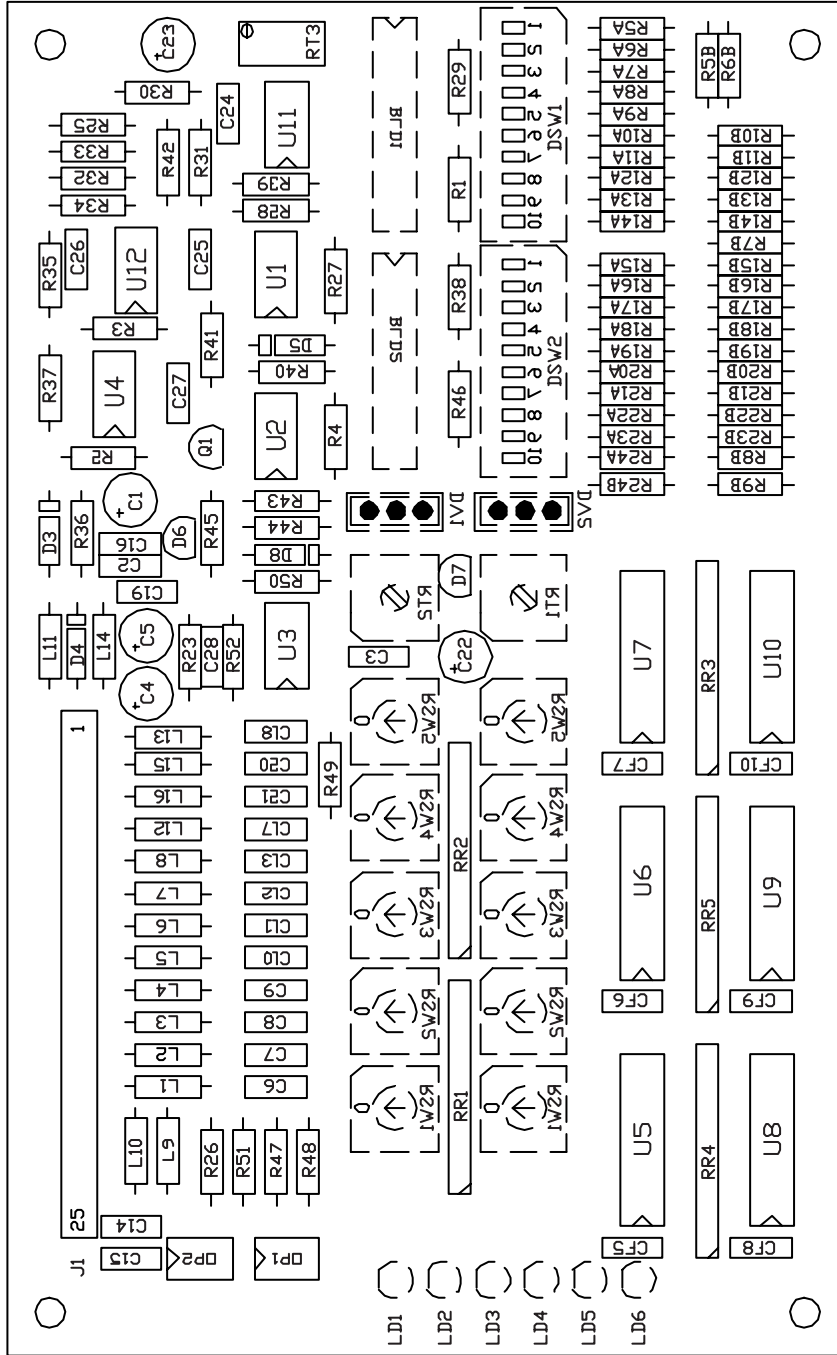

DATE	04/04/96	TITLE	SRT
FILE	L-SRT2	POWER and FREQUENCY SETTING	
REV.			
SHEET	1 OF 1		

REVISIONS
 REV. NO. _____
 DATE _____
 BY _____
 CHECKED BY _____

WARNING: THIS DOCUMENT IS UNCLASSIFIED. IT IS THE PROPERTY OF THE U.S. GOVERNMENT. IT IS TO BE REPRODUCED AND TRANSMITTED IN ANY FORM AND BY ANY MEANS WITHOUT EXPRESS WRITTEN AUTHORIZATION BY THE U.S. GOVERNMENT. ANY OFFENSES ARE LIABLE TO PAY ALL RELEVANT DAMAGES.

SRT BOARD PART LIST

R1	RESISTOR 1% 0.25W	330	R32	RESISTOR 1% 0.25W	470
R2	RESISTOR 1% 0.25W	100	R33		
R3	RESISTOR 1% 0.25W	56K	R34	RESISTOR 1% 0.25W	33K
R4	RESISTOR 1% 0.25W	820	R35	RESISTOR 1% 0.25W	47K
R5A	RESISTOR 1% 0.25W	32.4K	R36	RESISTOR 1% 0.25W	820
R5B	RESISTOR 1% 0.25W	34K	R37	RESISTOR 1% 0.25W	47K
R6A	RESISTOR 1% 0.25W	24.3K	R38	RESISTOR 1% 0.25W	10K
R6B	RESISTOR 1% 0.25W	18.2K	R39	RESISTOR 1% 0.25W	33K
R7A	RESISTOR 1% 0.25W	34K	R40	RESISTOR 1% 0.25W	10K
R7B	RESISTOR 1% 0.25W	331	R41		
R8A	RESISTOR 1% 0.25W	28K	R42	RESISTOR 1% 0.25W	33K
R8B	RESISTOR 1% 0.25W	1K	R43	RESISTOR 1% 0.25W	4.7K
R9A	RESISTOR 1% 0.25W	24.3	R44	RESISTOR 1% 0.25W	820
R9B	RESISTOR 1% 0.25W	1,21K	R45	RESISTOR 1% 0.25W	820
R10A	RESISTOR 1% 0.25W	22.1K	R46	RESISTOR 1% 0.25W	5.6K
R10B	RESISTOR 1% 0.25W	845	R47	RESISTOR 1% 0.25W	1.5K
R11A	RESISTOR 1% 0.25W	21.5K	R48	RESISTOR 1% 0.25W	15K
R11B	RESISTOR 1% 0.25W	165	R49	RESISTOR 1% 0.25W	12K
R12A	RESISTOR 1% 0.25W	19.1K	R50	RESISTOR 1% 0.25W	56K
R12B	RESISTOR 1% 0.25W	464	R51	RESISTOR 1% 0.25W	15K
R13A	RESISTOR 1% 0.25W	18.2K	R52	RESISTOR 1% 0.25W	12K
R13B	RESISTOR 1% 0.25W	68.1	RR1	INTEGRATED RESISTOR	10K
R14A	RESISTOR 1% 0.25W	16.5K	RR2i	INTEGRATED RESISTOR	10K
R14B	RESISTOR 1% 0.25W	845	RR3i	INTEGRATED RESISTOR	10K
R15A	RESISTOR 1% 0.25W	16.5K	RR4i	INTEGRATED RESISTOR	10K
R15B	RESISTOR 1% 0.25W	68.1	RR5i	INTEGRATED RESISTOR	10K
R16A	RESISTOR 1% 0.25W	15K	RT1	TRIMMER 1T	10K
R16B	RESISTOR 1% 0.25W	698	RT2	TRIMMER 1T	10K
R17A	RESISTOR 1% 0.25W	15K	RT3	TRIMMER 20T	10K
R17B	RESISTOR 1% 0.25W	150	C1	ELECTROLYTIC CAPACITOR	47 F
R18A	RESISTOR 1% 0.25W	14.3K	C2	CERAMIC CAPACITOR	100nF
R18B	RESISTOR 1% 0.25W	274	C3	CERAMIC CAPACITOR	100nF
R19A	RESISTOR 1% 0.25W	13.8K	C4	ELECTROLYTIC CAPACITOR	47 F
R19B	RESISTOR 1% 0.25W	221	C5		
R20A	RESISTOR 1% 0.25W	12.4K	C6	CERAMIC CAPACITOR	1nF
R20B	RESISTOR 1% 0.25W	1.13K	C7	CERAMIC CAPACITOR	1nF
R21A	RESISTOR 1% 0.25W	12.4K	C8	CERAMIC CAPACITOR	1nF
R21B	RESISTOR 1% 0.25W	681	C9	CERAMIC CAPACITOR	1nF
R22A	RESISTOR 1% 0.25W	11.8K	C10	CERAMIC CAPACITOR	1nF
R22B	RESISTOR 1% 0.25W	845	C11	CERAMIC CAPACITOR	1nF
R23A	RESISTOR 1% 0.25W	12.1K	C12	CERAMIC CAPACITOR	1nF
R23B	RESISTOR 1% 0.25W	221	C13	CERAMIC CAPACITOR	1nF
24A	RESISTOR 1% 0.25W	11.8K	C14	CERAMIC CAPACITOR	1nF
R24B	RESISTOR 1% 0.25W	221	C15	CERAMIC CAPACITOR	1nF
R25	RESISTOR 1% 0.25W	150K	C16	CERAMIC CAPACITOR	1nF
R25	RESISTOR 1% 0.25W	1.5K	C17	CERAMIC CAPACITOR	1nF
R27	RESISTOR 1% 0.25W	470K	C18	CERAMIC CAPACITOR	1nF
R28	RESISTOR 1% 0.25W	10K	C19	CERAMIC CAPACITOR	1nF
R29	RESISTOR 1% 0.25W	6.8K	C20	CERAMIC CAPACITOR	1nF
R30	RESISTOR 1% 0.25W	10K	C21	CERAMIC CAPACITOR	1nF
R31	RESISTOR 1% 0.25W	10K	C22	ELECTROLYTIC CAPACITOR	47 F

C23	ELECTROLYTIC CAPACITOR	10 F	U7	INTEGRATED CIRCUIT	CD4014
C24	CERAMIC CAPACITOR	100nF	U8	INTEGRATED CIRCUIT	CD4014
C25	CERAMIC CAPACITOR	1 F	U9	INTEGRATED CIRCUIT	CD4014
C26	CERAMIC CAPACITOR	220nF	U10	INTEGRATED CIRCUIT	CD4014
C27	CERAMIC CAPACITOR	100nF	U11	INTEGRATED CIRCUIT	LM358
C28	CERAMIC CAPACITOR	100nF	U12	INTEGRATED CIRCUIT	LM358
L1	INDUCTOR	8.2 H	U13	INTEGRATED CIRCUIT	LM358
L2	INDUCTOR	8.2 H	U14	INTEGRATED CIRCUIT	LM358
L3	INDUCTOR	8.2 H	U15	INTEGRATED CIRCUIT	LM358
L4	INDUCTOR	8.2 H	U16	INTEGRATED CIRCUIT	LM358
L5	INDUCTOR	8.2 H	CP6	CERAMIC CAPACITOR	100nF
L6	INDUCTOR	8.2 H	CP7	CERAMIC CAPACITOR	100nF
L7	INDUCTOR	8.2 H	CP8	CERAMIC CAPACITOR	100nF
L8	INDUCTOR	8.2 H	CP9	CERAMIC CAPACITOR	100nF
L9	INDUCTOR	8.2 H	CP10	CERAMIC CAPACITOR	100nF
L10	INDUCTOR	8.2 H	J1	CONNECTOR	SHF 20p
L11	INDUCTOR	8.2 H	BLD1	BAR LED	MV57164
L12	INDUCTOR	8.2 H	BLD2	BAR LED	MV57164
L13	INDUCTOR	8.2 H	DV1	DIP SWITCH	10P
L14	INDUCTOR	8.2 H	DV2	DIP SWITCH	10P
L15	INDUCTOR	8.2 H	DSW1	JUMPER	
L16	INDUCTOR	8.2 H	DSW2	JUMPER	
D1	DIODE	LED	RSW1	ROTARY SWITCH	
D2	DIODE	LED	RSW2	ROTARY SWITCH	
D3	DIODE	Zener 15V	RSW3	ROTARY SWITCH	
D4	DIODE	1N4148	RSW4	ROTARY SWITCH	
D5	DIODE	1N4148	RSW5	ROTARY SWITCH	
D6	REFERENCE I.C.	LM336/5V	RSW6	ROTARY SWITCH	
D7	REFERENCE I.C.	LM336/5V	RSW7	ROTARY SWITCH	
Q1	TRANSISTOR	BC183	RSW8	ROTARY SWITCH	
U5	INTEGRATED CIRCUIT	CD4014	RSW9	ROTARY SWITCH	
U6	INTEGRATED CIRCUIT	CD4014	RSW10	ROTARY SWITCH	

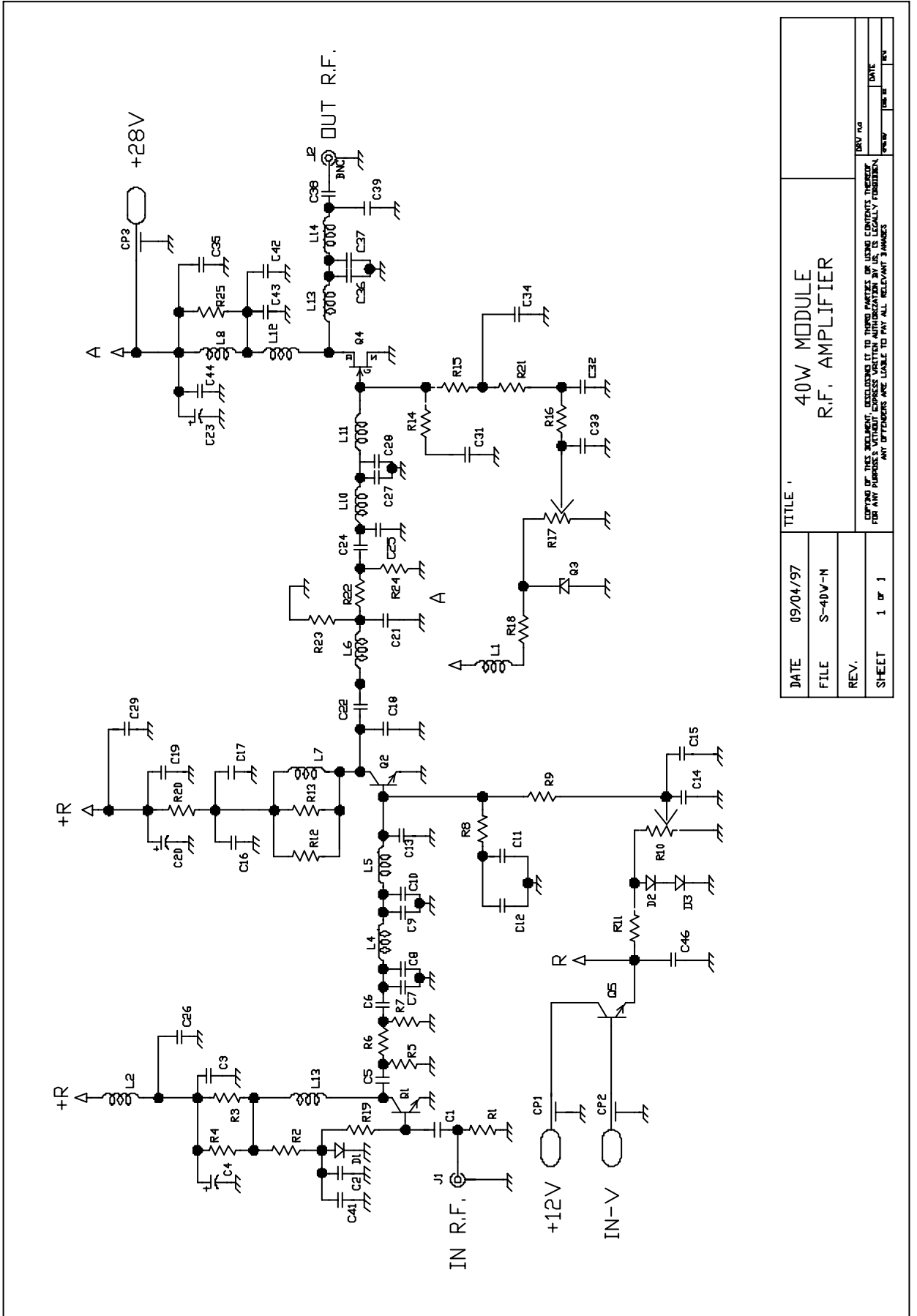

DATE 09/04/97		TITLE 40W MODULE	
FILE S-40V-N		R.F. AMPLIFIER	
REV.			
SHEET 1 of 1		<small> COPYING OF THIS DOCUMENT, INCLUDING ITS PARTS, OR USING CONTENTS THEREOF FOR ANY PURPOSES WITHOUT THE WRITTEN PERMISSION OF THE COMPANY IS PROHIBITED. ANY OFFENDERS ARE LIABLE TO PAY ALL RELEVANT FINES. </small>	

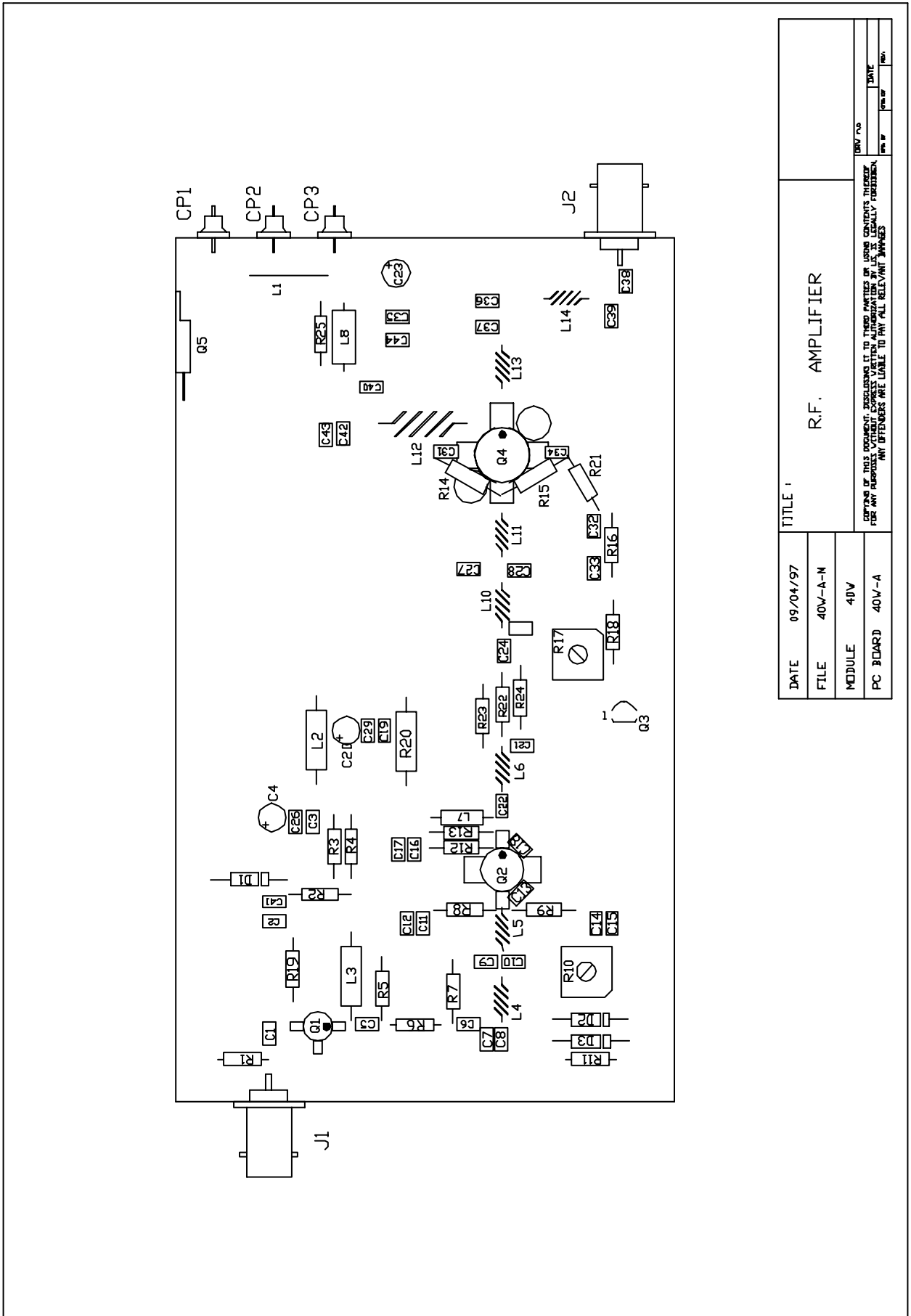

TITLE :		R.F. AMPLIFIER	
DATE	09/04/97	FILE	40V-A-N
		MODULE	40V
		PC BOARD	40V-A
<small> PORTIONS OF THIS DOCUMENT DISCLOSES IT TO THIRD PARTIES OR USING CONTENTS THEREOF FOR ANY PURPOSES WITHOUT EXPRESS WRITTEN AUTHORIZATION BY LIT. IS LEGALLY PROHIBITED. ANY OFFENDERS ARE LIABLE TO PAY ALL RELEVANT DAMAGES. </small>			
REV. NO.		DATE	
REV. BY		REV. NO.	

40W MODULE PART LIST

R1	RESISTOR 1% 1/4W	56	C25	CERAMIC CAPACITOR	68pF
R2	RESISTOR 1% 1/4W	5.6K	C26	CERAMIC CAPACITOR	1nF
R3	RESISTOR 1% 1/4W	180	C27	CERAMIC CAPACITOR	100pF
R4	RESISTOR 1% 1/4W	180	C28	CERAMIC CAPACITOR	100pF
R5	CHIP RESISTOR	470	C29	CERAMIC CAPACITOR	100nF
R6	CHIP RESISTOR	10	C30	CERAMIC CAPACITOR	1nF
R7	CHIPRESISTOR	470	C31	CERAMIC CAPACITOR	1nF
R8	RESISTOR 1% 1/4W	10	C32	CERAMIC CAPACITOR	100nF
R9	RESISTOR 1% 1/4W	10	C33	CERAMIC CAPACITOR	1nF
R10	TRIMMER 1T	500	C34	CERAMIC CAPACITOR	100nF
R11	RESISTOR 1% 1/4W	680	C35	CERAMIC CAPACITOR	1nF
R12	RESISTOR 1% 1/4W	220	C36	CERAMIC CAPACITOR	100pF
R13	RESISTOR 1% 1/4W	220	C37	CERAMIC CAPACITOR	100pF
R14	RESISTOR 5% 2W	10	C38	CERAMIC CAPACITOR	1nF
R15	RESISTOR 5% 2W	10	C39	CERAMIC CAPACITOR	68pF
R16	RESISTOR 1% 1/4W	5.6K	C40	CERAMIC CAPACITOR	1nF
R17	TRIMMER 1T	10K	C41	CERAMIC CAPACITOR	100nF
R18	RESISTOR 1% 1/4W	6.8K	C42	CERAMIC CAPACITOR	1nF
R19	RESISTOR 1% 1/4W	270	C43	CERAMIC CAPACITOR	100nF
R20	RESISTOR 20% 2W	1	C44	CERAMIC CAPACITOR	100nF
R21	RESISTOR 1% 1/4W	5.6K	CP1	FT CAPACITOR	1nF
R22	CARBON RESISTOR 5% 2W	10	CP2	FT CAPACITOR	1nF
R23	CARBON RESISTOR 5% 2W	270	CP3	FT CAPACITOR	1nF
R24	CARBON RESISTOR 5% 2W	270	L1	SHORT-CIRCUIT	
R25	CARBON RESISTOR 5% 2W	10	L2	INDUCTOR	2.2 H
C1	CERAMIC CAPACITOR	1nF	L3	INDUCTOR	2.2 H
C2	CERAMIC CAPACITOR	1nF	L4	COIL	EL401
C3	CERAMIC CAPACITOR	1nF	L5	COIL	EL402
C4	ELECTROLYTIC CAPACITOR 47 F/35V		L6	COIL	EL403
C5	CERAMIC CAPACITOR	1nF	L7	INDUCTOR	1.5 H
C6	CERAMIC CAPACITOR	1nF	L8	INDUCTOR	VK200
C7	CERAMIC CAPACITOR	4.7pF	L9	COIL	EL404
C8	CERAMIC CAPACITOR	47pF	L10	COIL	EL405
C9	CERAMIC CAPACITOR	56pF	L11	COIL	EL406
C10	CERAMIC CAPACITOR	100pF	L12	COIL	EL407
C11	CERAMIC CAPACITOR	1nF	L13	COIL	EL408
C12	CERAMIC CAPACITOR	100nF	L14	COIL	EL409
C13	CERAMIC CAPACITOR	82pF	D1	DIODE	1N4148
C14	CERAMIC CAPACITOR	1nF	D2	DIODE	1N4148
C15	CERAMIC CAPACITOR	100nF	D3	DIODE	1N4148
C16	CERAMIC CAPACITOR	1nF	Q1	TRANSISTOR	BFR96
C17	CERAMIC CAPACITOR	100nF	Q2	TRANSISTOR	BFQ68
C18	CERAMIC CAPACITOR	22pF	Q3	REFERENCE I.C.	LM336/5V
C19	CERAMIC CAPACITOR	1nF	Q4	TRANSISTOR	DU2860U
C20	ELECTROLYTIC CAPACITOR 47 F/35V		Q5	DARLINGTON	TIP122
C21	CERAMIC CAPACITOR	39pF	J1	BNC CONNECTOR	
C22	CERAMIC CAPACITOR	1nF	J2	BNC CONNECTOR	
C23	ELECTROLYTIC CAPACITOR 47 F/35V				
C24	CERAMIC CAPACITOR	1nF			

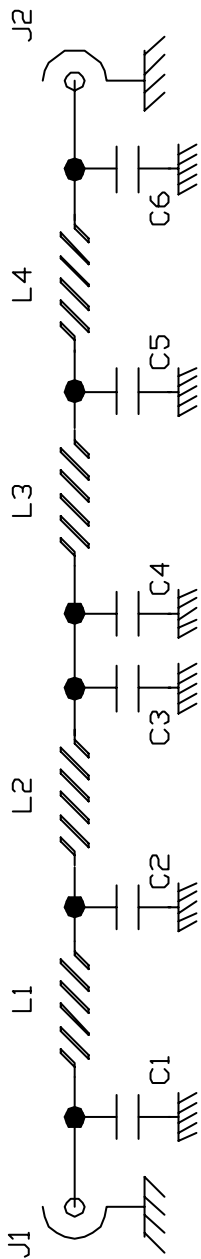

DATE	08-12-93	TITLE	FPB40
FILE	S-FPB40		LOW-PASS FILTER
REV.			
SHEET	1 of 1	<small> COPYING OF THIS DOCUMENT, INCLUDING ITS THIRD PARTIES, OR USING CONTENTS THEREOF FOR ANY PURPOSES WITHOUT THE WRITTEN PERMISSION OF THE ORIGINAL AUTHOR IS PROHIBITED. ANY OFFENDERS ARE LIABLE TO PAY ALL RELEVANT DAMAGES. </small>	
		REV. NO.	
		DATE	
		REV.	

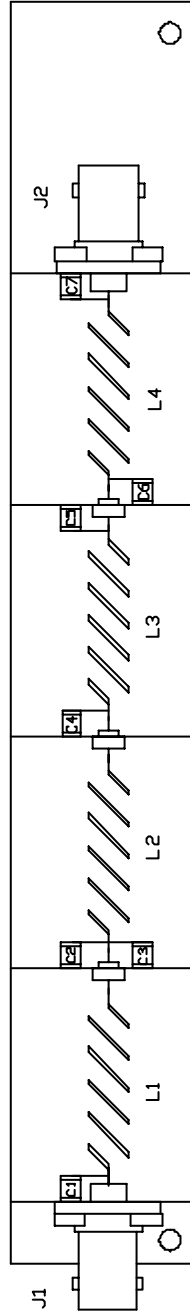

DATE	10/4/96	TITLE	LPF40	REV. NO.	
FILE	FPB40-2		LOW-PASS FILTER	REV. BY	
REV.		DEPENDING ON THIS DOCUMENT, DISCLOSURE OF ITS CONTENTS, REPRODUCTION, FOR ANY PURPOSES WITHOUT EXPRESS WRITTEN AUTHORIZATION BY USE, IS LEGALLY PROHIBITED. ANY OFFENDERS ARE LIABLE TO PAY ALL RELEVANT DAMAGES.			
SHEET	1 OF 1			DATE	

FPB40 MODULE PART LIST

C1	HP CERAMIC CAPACITOR	22pF
C2	HP CERAMIC CAPACITOR	47pF
C3	HP CERAMIC CAPACITOR	47pF
C4	HP CERAMIC CAPACITOR	33pF
C5	HP CERAMIC CAPACITOR	47pF
C6	HP CERAMIC CAPACITOR	22pF
L1	COIL	
L2	COIL	
L3	COIL	
L4	COIL	
J1	BNC CONNECTOR	
J2	BNC CONNECTOR	

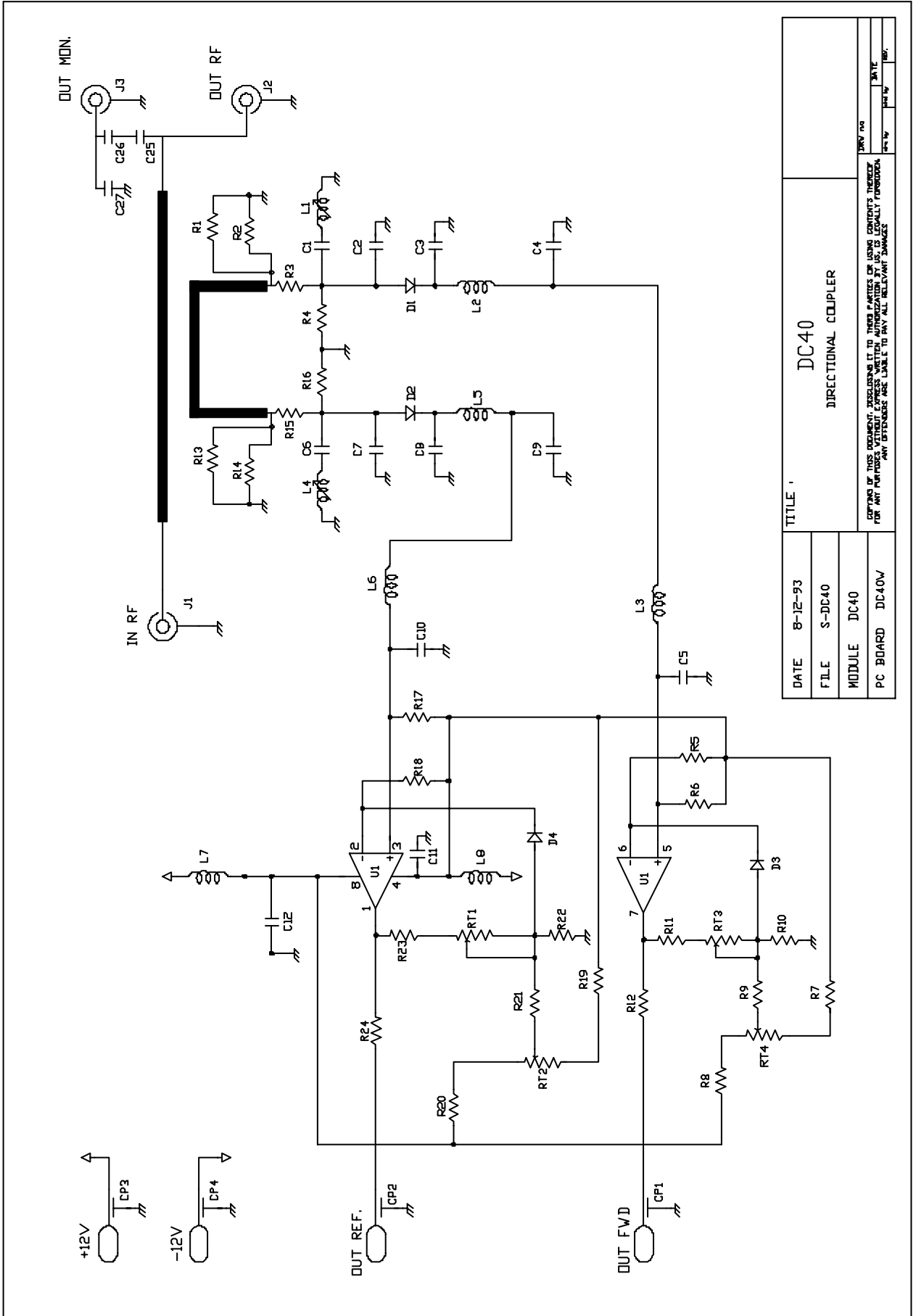

DATE	8-12-93	TITLE	DC40
FILE	S-DC40		DIRECTIONAL COUPLER
MODULE	DC40		
PC BOARD	DC40V		

REVISIONS

REV	NO	DATE	BY

WARNING: THIS DOCUMENT, INCLUDING IT, AND THE PARTS OF IT, ARE UNCLASSIFIED INFORMATION. ANY EXTENSION OF THIS DOCUMENT IS SUBJECT TO THE SAME SECURITY REQUIREMENTS AS THE ORIGINAL DOCUMENT.

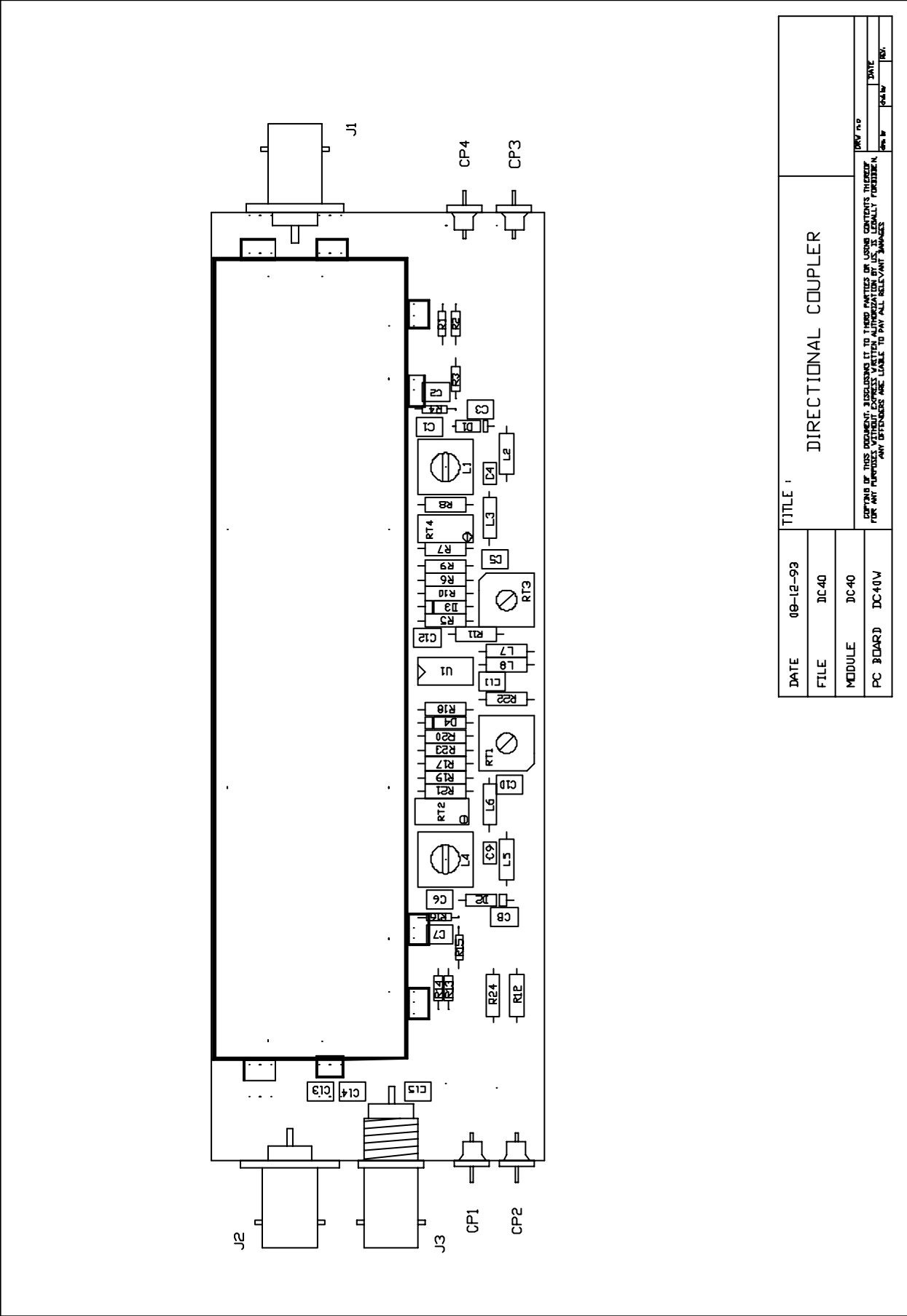

DATE	09-12-93	TITLE	DIRECTIONAL COUPLER
FILE	DC-40		
MODULE	DC-40		
PC BOARD	DC40V		
<small> COPIES OF THIS DOCUMENT, DISCLOSING IT TO THIRD PARTIES OR USING CONTENTS THEREOF FOR ANY PURPOSES, WITHOUT EXPRESS WRITTEN AUTHORIZATION OF U.S. IS LEGALLY PROHIBITED. ANY VIOLATION WILL BE PROSECUTED TO THE FULL EXTENT OF THE LAW. </small>			
		REV. NO.	DATE
		1001	1993

CD40 MODULE PART LIST

R1	RESISTOR 5% 1W	56	C5	CERAMIC CAPACITOR	1nF
R2	RESISTOR 1% 1/4W		C6	CERAMIC CAPACITOR	1nF
R3	RESISTOR 5% 1/8W	150	C7	CERAMIC CAPACITOR	1nF
R4	RESISTOR 5% 1/8W	680	C8	CERAMIC CAPACITOR	15pF
R5	RESISTOR 1% 1/4W	220K	C9	CERAMIC CAPACITOR	1.5nF
R6	RESISTOR 1% 1/4W	220K	C10	CERAMIC CAPACITOR	1nF
R7	RESISTOR 1% 1/4W	1K	C11	CERAMIC CAPACITOR	1nF
R8	RESISTOR 1% 1/4W	1K	C12	CERAMIC CAPACITOR	1nF
R9	RESISTOR 1% 1/4W	10K	C13	CERAMIC CAPACITOR	0.3pF
R10	RESISTOR 1% 1/4W	270	C14	CERAMIC CAPACITOR	0.3pF
R11	RESISTOR 1% 1/4W	270	C15	CERAMIC CAPACITOR	1nF
R12	RESISTOR 1% 1/4W	270	CP1	FT CAPACITOR	1nF
R13	RESISTOR 5% 1W	56	CP2	FT CAPACITOR	1nF
R14	RESISTOR 5% 1/8W		CP3	FT CAPACITOR	1nF
R15	RESISTOR 5% 1/8W	150	CP4	FT CAPACITOR	1nF
R16	RESISTOR 5% 1/8W	680	L1	INDUCTOR	6T
R17	RESISTOR 1% 1/4W	220K	L2	INDUCTOR	2.2 H
R18	RESISTOR 1% 1/4W	220K	L3	INDUCTOR	2.2 H
R19	RESISTOR 1% 1/4W	1K	L4	INDUCTOR	6T
R20	RESISTOR 1% 1/4W	1K	L5	INDUCTOR	2.2 H
R21	RESISTOR 1% 1/4W	10K	L6	INDUCTOR	2.2 H
R22	RESISTOR 1% 1/4W	270K	L7	INDUCTOR	2.2 H
R23	RESISTOR 1% 1/4W	270K	L8	INDUCTOR	2.2 H
R24	RESISTOR 1% 1/4W	10K	D1	DIODE	1SS
RT1	TRIMMER 1T	2.2K	D2	DIODE	1SS
RT2	TRIMMER 10T	2.2K	D3	DIODE	1SS
RT3	TRIMMER 1T	2.2K	D4	DIODE	1SS
RT4	TRIMMER 10T	2.2K	U1	INTEGRATED CIRCUIT	LM358
C1	CERAMIC CAPACITOR	1nF	J1	BNC CONNECTOR	
C2	CERAMIC CAPACITOR	1nF	J2	BNC CONNECTOR	
C3	CERAMIC CAPACITOR	15pF	J3	BNC CONNECTOR	
C4	CERAMIC CAPACITOR	1.5nF			

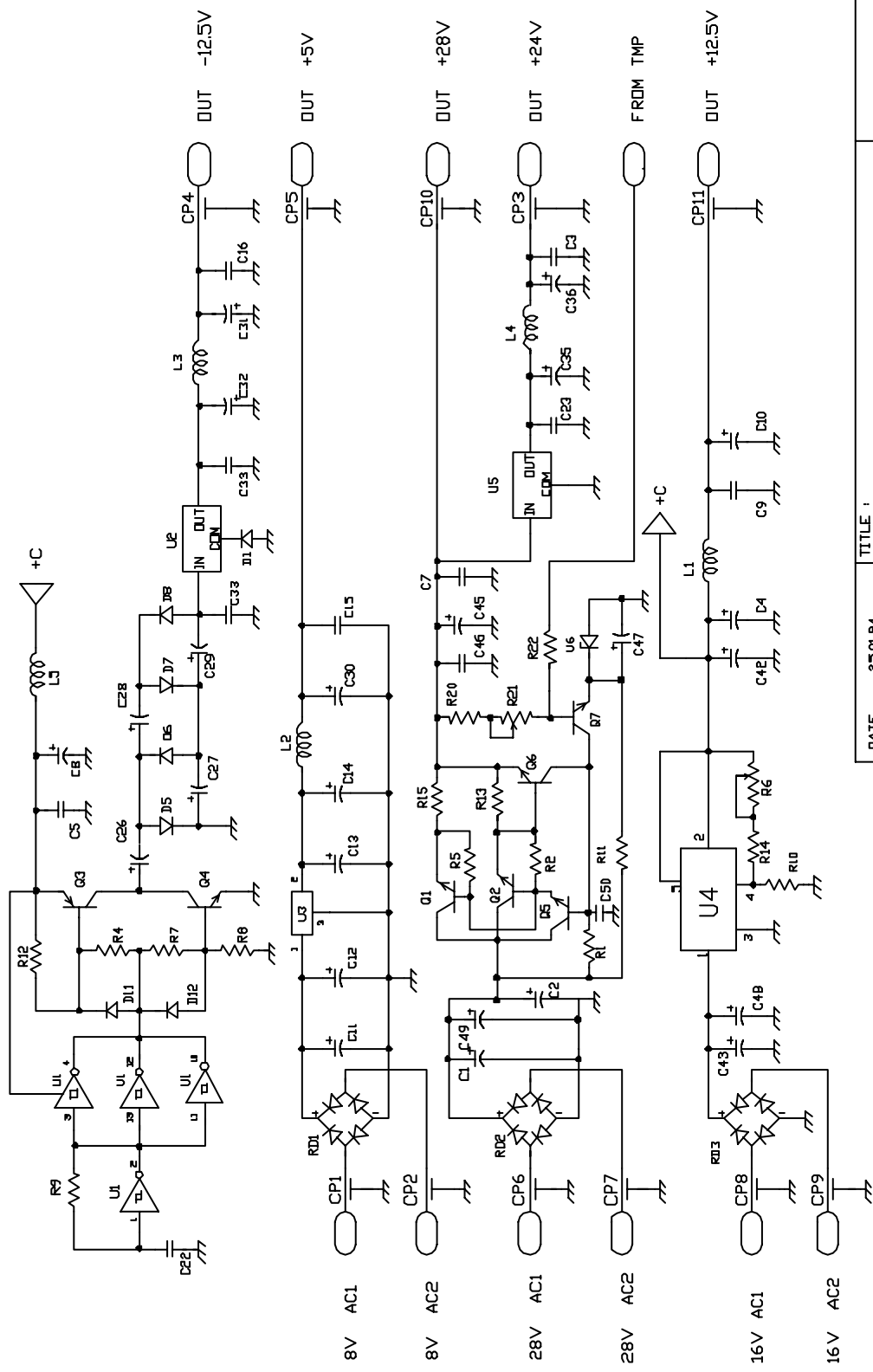

DATE		23.01.94	
FILE		S-ALS40T	
MODULE		ALS40	
PC BOARD		ALS40	
TITLE : DC POWER SUPPLY			
DRAW NO		DATE	
REV		REV	

COMPANY OF THIS DOCUMENT, INCLUDING IT, THESE PARTS OF USING COMPANY'S THEORY FOR PART PERFORMANCE ARE LIABLE TO PAY ALL NECESSARY DAMAGES.

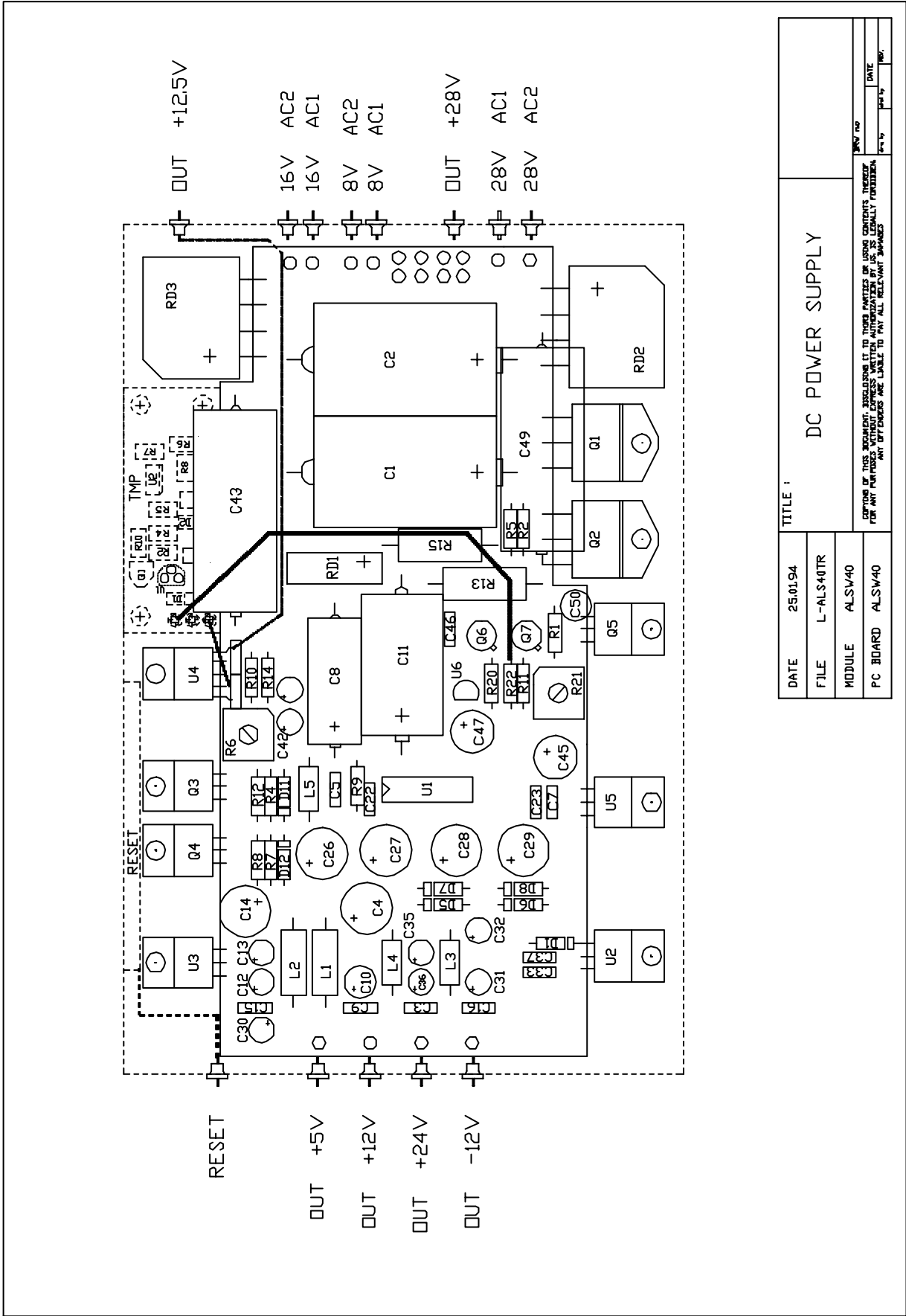

DATE	25.01.94	TITLE	DC POWER SUPPLY
FILE	L-ALS40TR		
MODULE	ALS/W40		
PC BOARD	ALS/W40		

PORTION OF THIS DOCUMENT, INCLUDING IT IN WHOLE OR IN PART, IS UNCLASSIFIED AND FOR OFFICIAL USE ONLY. IT IS THE PROPERTY OF THE AIR FORCE. IT IS TO BE REPRODUCED AND TRANSMITTED IN ANY FORM AND BY ANY MEANS, WITHOUT EXPRESS WRITTEN AUTHORIZATION BY THE AIR FORCE. ANY OFFENSES ARE LIABLE TO PAY ALL RELEVANT DAMAGES.

ALSW1 MODULE PART LIST

R1	RESISTOR 1% 1/4W	12K	C37	CERAMIC CAPACITOR	100nF
R2	RESISTOR 1% 1/8W	270	C42	ELECTROLYTIC CAPACITOR	4.7 F/25V
R4	RESISTOR 1% 1/4W	10K	C43	ELECTROLYTIC CAP.	4700 F/40V
R5	RESISTOR 1% 1/4W	270	C45	ELECTROLYTIC CAPACITOR	4.7 F/35V
R6	TRIMMER 1T	1K	C46	CERAMIC CAPACITOR	100nF
R7	RESISTOR 1% 1/4W	10K	C47	ELECTROLYTIC CAPACITOR	220 F/35V
R8	RESISTOR 1% 1/4W	6.8K	C48	ELECTROLYTIC CAPACITOR	4.7 F/35V
R9	RESISTOR 1% 1/4W	6.8K	C49	ELECTROLYTIC CAP.	
R10	RESISTOR 1% 1/4W	1.2K		(only for HPT60)	2200 F/63V
R11	RESISTOR 1% 1/4W	8.2K	C50	ELECTROLYTIC CAPACITOR	10 F/35V
R12	RESISTOR 1% 1/4W	2.7K	CP1	FT CAPACITOR	1000pF
R13	RESISTOR 5% 5W		CP2	F T CAPACITOR	1000pF
	(for HPT40)	0.33	CP3	F T CAPACITOR	1000pF
	(for HPT60)	0.22	CP4	F T CAPACITOR	1000pF
R14	RESISTOR 1% 1/4W	3.9K	CP5	F T CAPACITOR	1000pF
R15	RESISTOR 5% 5W		CP6	F T CAPACITOR	1000pF
	(for HPT40)	0.33	CP7	F T CAPACITOR	1000pF
	(for HPT60)	0.22	CP8	F T CAPACITOR	1000pF
R20	RESISTOR 1% 1/4W	3.3K	CP9	F T CAPACITOR	1000pF
R21	TRIMMER 1T	2K	CP10	FT CAPACITOR	1000pF
R22	RESISTOR 1% 1/4W	1K	CP11	FT CAPACITOR	1000pF
C1	ELECTROLYTIC CAPACITOR	2200 F/63V	L1	INDUCTOR	VK200
C2	ELECTROLYTIC CAPACITOR	2200 F/63V	L2	INDUCTOR	VK200
C3	CERAMIC CAPACITOR	100nF	L3	INDUCTOR	22 H
C4	ELECTROLYTIC CAPACITOR	220 F/25V	L4	INDUCTOR	VK200
C5	CERAMIC CAPACITOR	100nF	L5	INDUCTOR	22 H
C7	CERAMIC CAPACITOR	100nF	D1	DIODE	1N4148
C8	ELECTROLYTIC CAPACITOR	1000 F/25V	D5	DIODE	1N5818
C9	CERAMIC CAPACITOR	100nF	D6	DIODE	1N5818
C10	ELECTROLYTIC CAPACITOR	4.7 F/25V	D7	DIODE	1N5818
C11	ELECTROLYTIC CAPACITOR	2200 F/25V	D8	DIODE	1N5818
C12	ELECTROLYTIC CAPACITOR	0.68 F/25V	D11	DIODE	BAR10
C13	ELECTROLYTIC CAPACITOR	0.68 F/25V	D12	DIODE	BAR10
C14	ELECTROLYTIC CAPACITOR	220 F/25V	RD1	RECTIFIER BRIDGE	KBL04
C15	CERAMIC CAPACITOR	100nF	RD2	RECTIFIER BRIDGE	KBPC10
C16	CERAMIC CAPACITOR	100nF	RD3	RECTIFIER BRIDGE	KBL04
C22	POLYESTER CAPACITOR	6.8nF	U1	INTEGRATED CIRCUIT	74HC14
C23	CERAMIC CAPACITOR	100nF	U2	VOLTAGE REGULATOR	7912
C24	ELECTR. CAPACITOR EKR	220 F/25V	U3	VOLTAGE REGULATOR	7805
C26	ELECTR. CAPACITOR EKR	220 F/25V	U4	VOLTAGE REGULATOR	L200
C27	ELECTR. CAPACITOR EKR	220 F/25V	U5	VOLTAGE REGULATOR	7024
C28	ELECTR. CAPACITOR EKR	220 F/25V	U6	REFERENCE I.C.	LM336-5V
C29	ELECTR. CAPACITOR EKR	220 F/25V	Q1	DARLINGTON	TIP35
C30	ELECTR. CAPACITOR	4.7 F/25V	Q2	DARLINGTON	TIP35
C31	ELECTROLYTIC CAPACITOR	4.7 F/25V	Q3	DARLINGTON	TIP127
C32	ELECTROLYTIC CAPACITOR	4.7 F/25V	Q4	DARLINGTON	TIP122
C33	CERAMIC CAPACITOR	100nF	Q5	DARLINGTON	TIP122
C35	ELECTROLYTIC CAPACITOR	4.7 F/35V	Q6	TRANSISTOR	BVY59
C36	ELECTROLYTIC CAPACITOR	4.7 F/35V	Q7	TRANSISTOR	BCY59

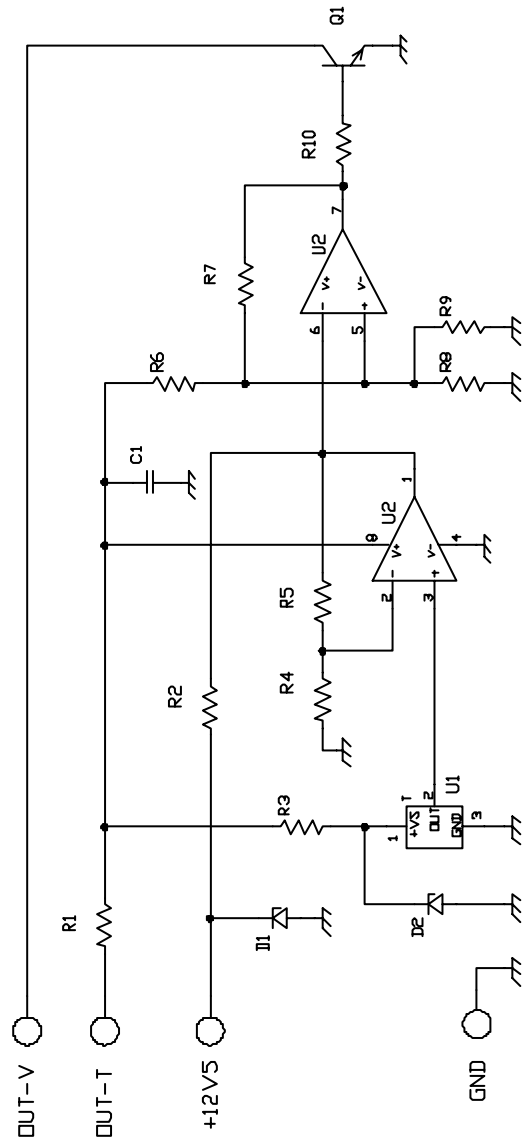

DATE	04/04/96	TITLE	1
FILE	S-TMP	TMP	
REV.		TEMPERATURE CONTROL	
SHEET	1 of 1	<small> DESIGN OF THIS DOCUMENT, DRAWINGS, AND/OR PARTS THEREOF, IS THE SOLE PROPERTY OF ELNOS. NO PART OF THIS DOCUMENT, DRAWINGS, AND/OR PARTS THEREOF, IS TO BE REPRODUCED, COPIED, OR TRANSMITTED IN ANY FORM OR BY ANY MEANS, WITHOUT EXPRESS WRITTEN AUTHORIZATION BY ELNOS. ELNOS ASSUMES NO LIABILITY FOR ANY DAMAGES, DIRECT OR INDIRECT, ARISING FROM THE USE OF THIS DOCUMENT, DRAWINGS, AND/OR PARTS THEREOF. ANY OFFENDERS ARE LIABLE TO PAY ALL RELEVANT DAMAGES. </small>	

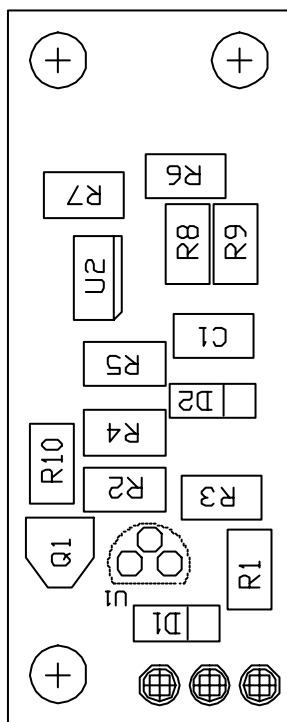

GND
 OUT-V
 OUT-T
 +12V5

DATE	04/04/96	TITLE	TMP
FILE	L-TMP	TEMPERATURE CONTROL	
REV.			
SHEET	1 of 1	<small> COPYING OF THIS DOCUMENT, EXCLUDING IT TO THIRD PARTIES OR USING CONTENTS THEREOF FOR ANY PURPOSES WITHOUT EXPRESS WRITTEN AUTHORIZATION BY U.S. IS LEGALLY PROHIBITED. ANY VIOLATIONS ARE LIABLE TO PAY ALL RELEVANT DAMAGES. </small>	
		REV. 704	
		REV. 704	REV. 704

TMP BOARD PART LIST

R1	SMD RESISTOR 1/8W 1%	100
R2	SMD RESISTOR 1/8W 1%	560
R3	SMD RESISTOR 1/8W 1%	1K
R4	SMD RESISTOR 1/8W 1%	10K
R5	SMD RESISTOR 1/8W 1%	15K
R6	SMD RESISTOR 1/8W 1%	8.2K
R7	SMD RESISTOR 1/8W 1%	82K
R8	SMD RESISTOR 1/8W 1%	22K
R9	SMD RESISTOR 1W 5%	3.3K
R10	SMD RESISTOR 1W 5%	10K
C1	CERAMIC SMD CAPACITOR	100nF
D1	SMD ZENER DIODE	5.1V
Q1	SMD TRANSISTOR	BCW33
U1	SMD TEMP. SENSOR	TMP37GT9
U1	SMD I.C.	LM358D

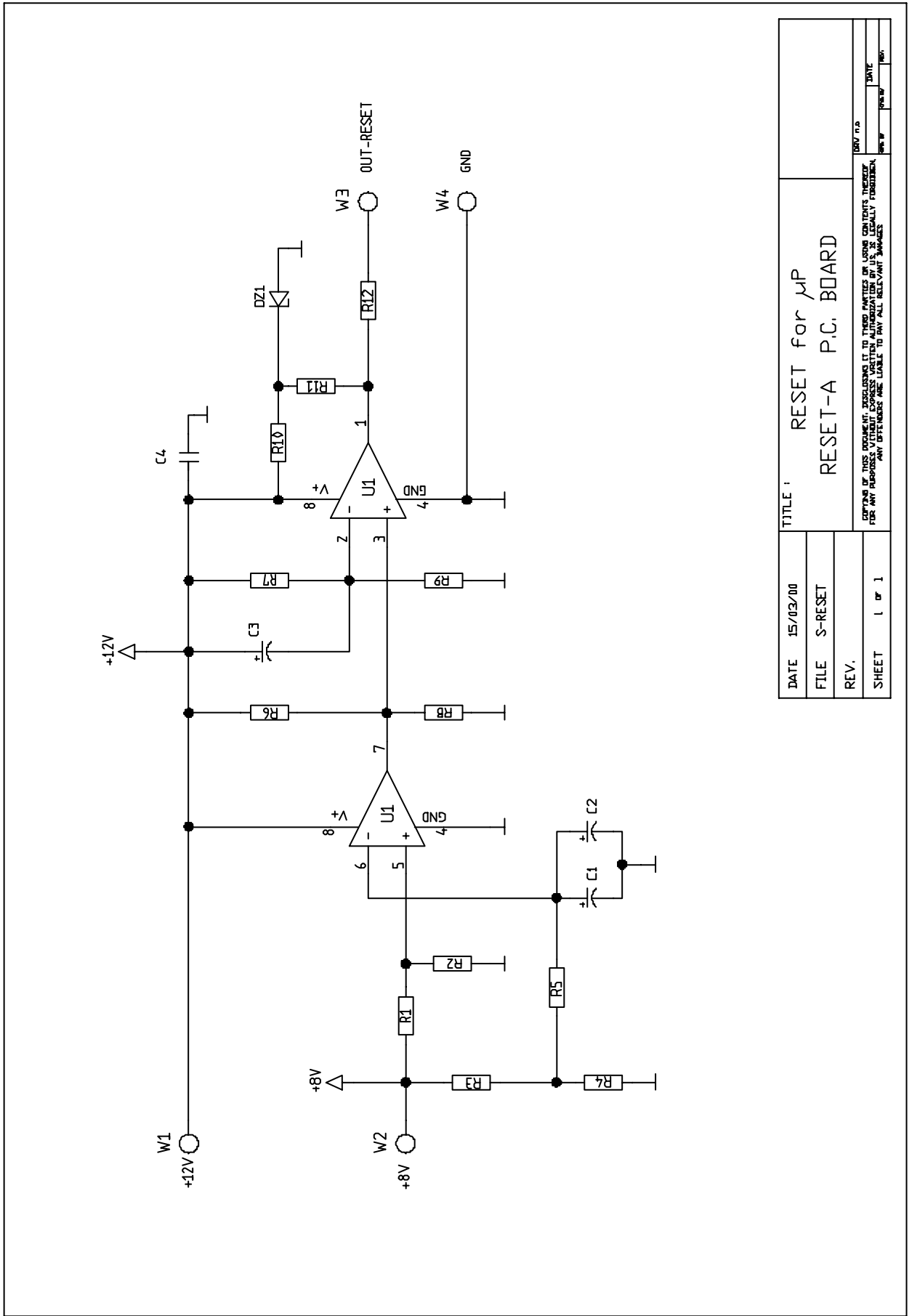

DATE	15/03/00	TITLE	RESET for μ P
FILE	S-RESET	RESET-A P.C. BOARD	
REV.			
SHEET	1 of 1		
		<small> DEPENDS OF THIS DOCUMENT, EXCLUDING IT, THESE PARTS OF USING CONTENTS THEREOF FOR ANY PURPOSES ARE LIABLE TO PAY ALL RELEVANT DAMAGES. DWG. NO. _____ DESIGNED BY _____ CHECKED BY _____ DATE _____ REV. NO. _____ </small>	

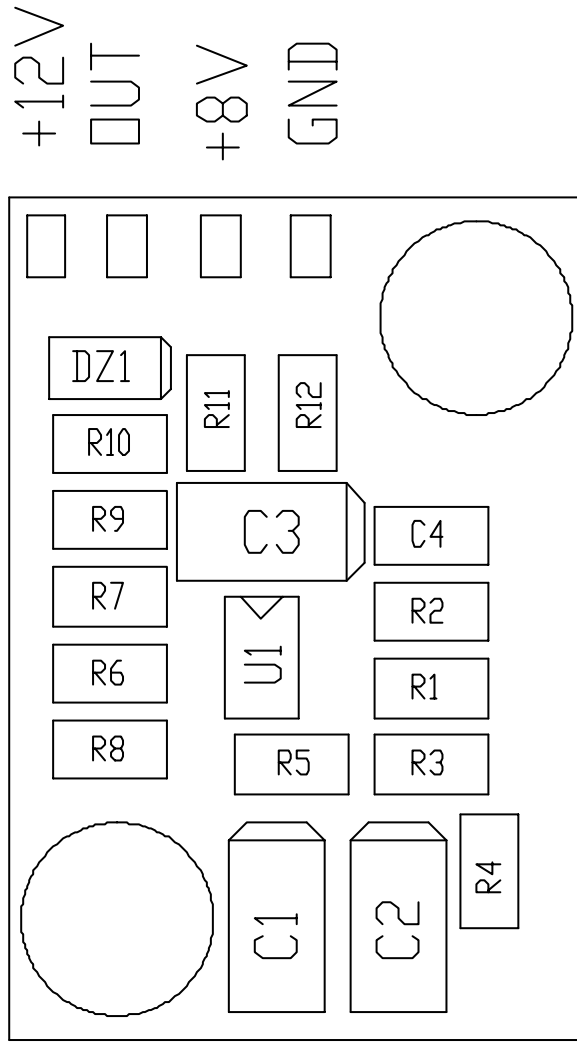

DATE	15/03/00	TITLE :	RESET for μ P
FILE	L-RESET	RESET-A P.C. BOARD	
REV.			
SHEET	1 of 1	<small> COPIES OF THIS DOCUMENT, DISCLOSURE TO THIRD PARTIES OR USING CONTENTS THEREOF FOR ANY PURPOSES WITHOUT EXPRESS WRITTEN AUTHORIZATION BY AS, IS LEGALLY PROHIBITED. ANY OFFENCES ARE LIABLE TO PAY ALL RELEVANT DAMAGES. </small>	
		<small> DWG no Date by Rev. by </small>	<small> DATE BY </small>

RESET BOARD PART LIST

R1	SMD RESISTOR 1/8W 1%	2.2k
R2	SMD RESISTOR 1/8W 1%	8.2k
R3	SMD RESISTOR 1/8W 1%	3.9k
R4	SMD RESISTOR 1/8W 1%	8.2k
R5	SMD RESISTOR 1/8W 1%	180k
R6	SMD RESISTOR 1/8W 1%	8.2k
R7	SMD RESISTOR 1/8W 1%	100k
R8	SMD RESISTOR 1/8W 1%	8.2k
R9	SMD RESISTOR 1W 5%	56k
R10	SMD RESISTOR 1W 5%	1k
R11	SMD RESISTOR 1/8W 1%	2.2k
R12	SMD RESISTOR 1/8W 1%	330
C1	TANTALUM SMD CAPACITOR	10 F/16V
C2	TANTALUM SMD CAPACITOR	10 F/16V
C3	TANTALUM SMD CAPACITOR	10 F/16V
C4	CERAMIC SMD CAPACITOR	100nF
DZ1	SMD ZENER DIODE	5.1V
U1	SMD INTEGRATED CIRCUIT	

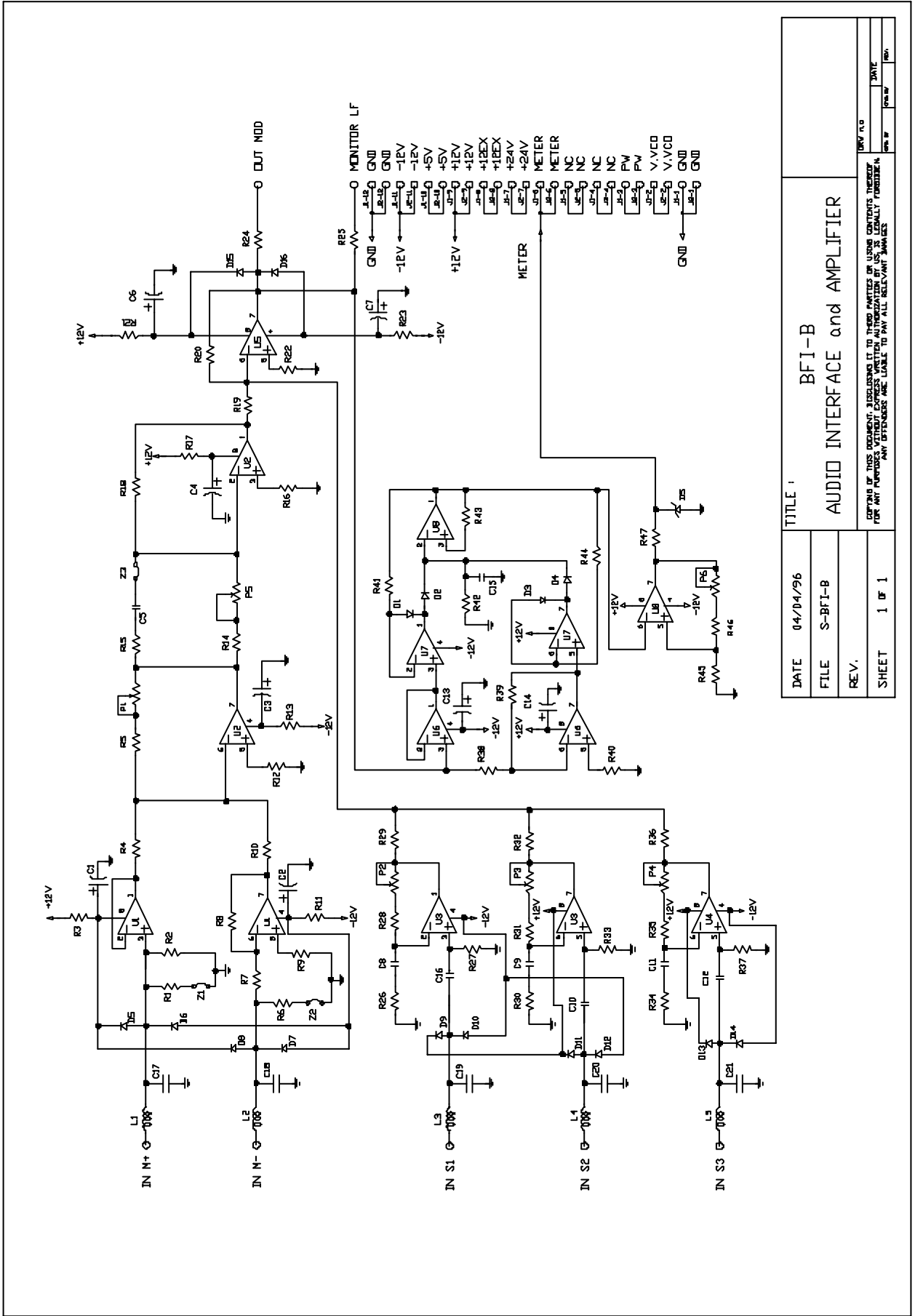

DATE 04/04/96		TITLE 1	
FILE S-BFI-B		BFI-B	
REV.		AUDIO INTERFACE and AMPLIFIER	
SHEET 1 OF 1		<small>OWNER OF THIS DOCUMENT AGREES TO THE TERMS AND CONDITIONS HEREOF FOR ANY PURPOSES WITHOUT EXPRESS WRITTEN AUTHORIZATION OF US. NO LIABILITY FOR INDEMNIFICATION OR DAMAGES. ANY OFFENSES ARE LIABLE TO PAY ALL RELEVANT DAMAGES.</small>	

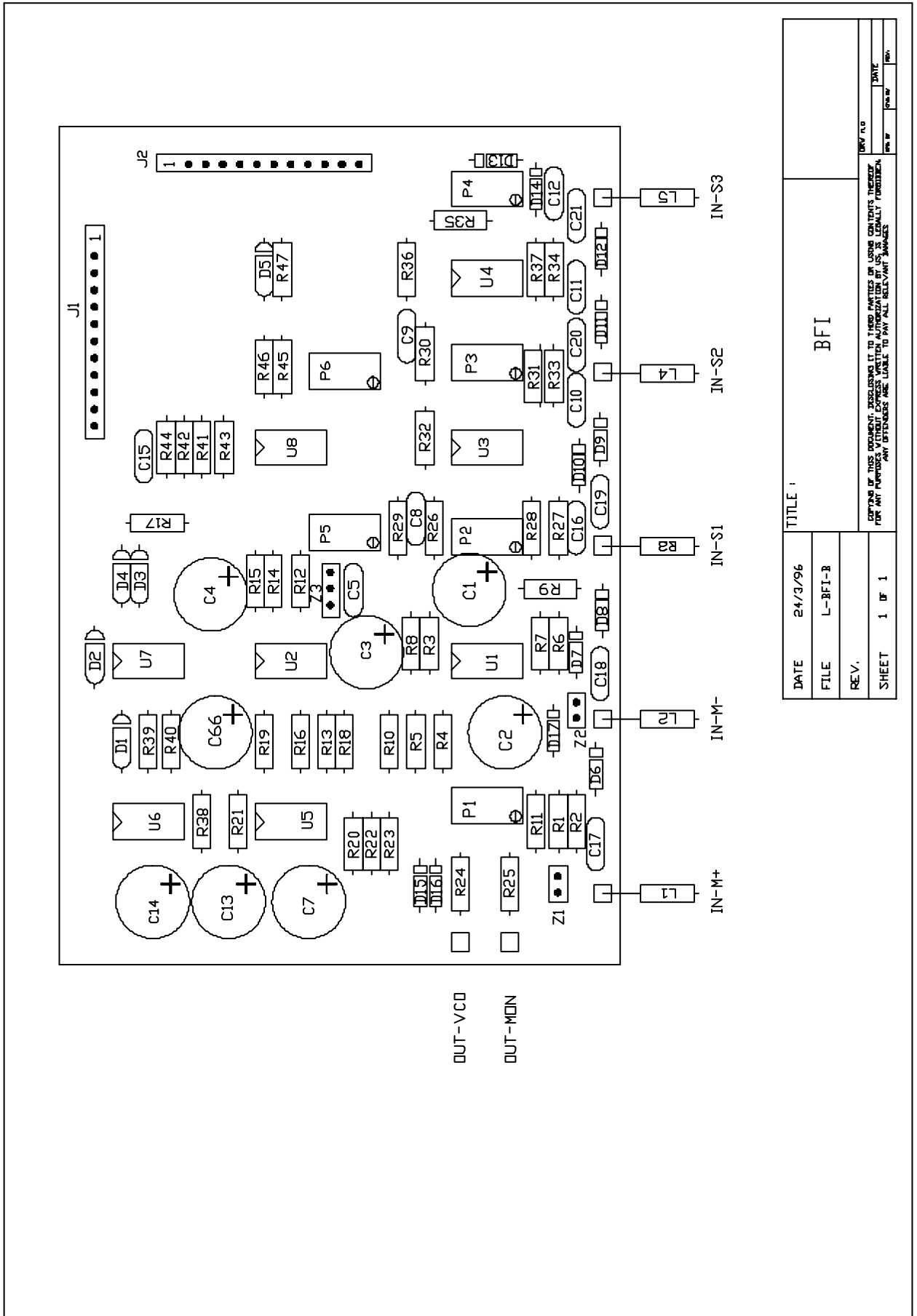

BFI BOARD PART LIST

R1	RESISTOR 1% 0.25W	680	P5	TRIMMER 10T	10K
R2	RESISTOR 1% 0.25W	10K	P6	TRIMMER 10T	20K
R3	RESISTOR 1% 0.25W	820	C1	ELECTROLYTIC CAPACITOR	220 F-25V
R4	RESISTOR 1% 0.25W	10K	C2	ELECTROLYTIC CAPACITOR	220 F-25V
R5	RESISTOR 1% 0.25W	4.7K	C3	ELECTROLYTIC CAPACITOR	220 F-25V
R6	RESISTOR 1% 0.25W	680	C4	ELECTROLYTIC CAPACITOR	220 F-25V
R7	RESISTOR 1% 0.25W	10K	C5	POLICARB. CAPACITOR	4.7nF
R8	RESISTOR 1% 0.25W	10K	C6	ELECTROLYTIC CAPACITOR	220 F-25V
R9	RESISTOR 1% 0.25W	4.7K	C7	ELECTROLYTIC CAPACITOR	220 F-25V
R10	RESISTOR 1% 0.25W	10K	C8	POLICARB. CAPACITOR	2.2nF
R11	RESISTOR 1% 0.25W	820	C9	POLICARB. CAPACITOR	2.2nF
R12	RESISTOR 1% 0.25W	470	C10	POLICARB. CAPACITOR	2.2nF
R13	RESISTOR 1% 0.25W	820	C11	POLICARB. CAPACITOR	2.2nF
R14	RESISTOR 1% 0.25W	8.2K	C12	POLICARB. CAPACITOR	2.2nF
R15	RESISTOR 1% 0.25W	560	C13	ELECTROLYTIC CAPACITOR	220 F-25V
R16	RESISTOR 1% 0.25W	470	C14	ELECTROLYTIC CAPACITOR	220 F-25V
R17	RESISTOR 1% 0.25W	820	C15	POLICARB. CAPACITOR	22nF
R18	RESISTOR 1% 0.25W	18K	C16	POLICARB. CAPACITOR	2n2F
R19	RESISTOR 1% 0.25W	10K	C17	CERAMIC CAPACITOR	100pF
R20	RESISTOR 1% 0.25W	5.6K	C18	CERAMIC CAPACITOR	100pF
R21	RESISTOR 1% 0.25W	820	C19	CERAMIC CAPACITOR	1nF
R22	RESISTOR 1% 0.25W	470	C20	CERAMIC CAPACITOR	1nF
R23	RESISTOR 1% 0.25W	820	C21	CERAMIC CAPACITOR	1nF
R24	RESISTOR 1% 0.25W	47	C66	ELECTROLYTIC CAPACITOR	220 F-25V
R25	RESISTOR 1% 0.25W	680	D1	DIODE	BAT82
R26	RESISTOR 1% 0.25W	10K	D2	DIODE	IN4148
R27	RESISTOR 1% 0.25W	10K	D3	DIODE	BAT82
R28	RESISTOR 1% 0.25W	10K	D4	DIODE	IN4148
R29	RESISTOR 1% 0.25W	120K	D6	DIODE	BAV21
R30	RESISTOR 1% 0.25W	10K	D7	DIODE	BAV21
R31	RESISTOR 1% 0.25W	10K	D8	DIODE	BAV21
R32	RESISTOR 1% 0.25W	120K	D9	DIODE	BAV21
R33	RESISTOR 1% 0.25W	10K	D10	DIODE	BAV21
R34	RESISTOR 1% 0.25W	10K	D11	DIODE	BAV21
R35	RESISTOR 1% 0.25W	10K	D12	DIODE	BAV21
R36	RESISTOR 1% 0.25W	120K	D13	DIODE	BAV21
R37	RESISTOR 1% 0.25W	10K	D14	DIODE	BAV21
R38	RESISTOR 1% 0.25W	10K	D15	DIODE	BAV21
R39	RESISTOR 1% 0.25W	10K	D16	DIODE	BAV21
R40	RESISTOR 1% 0.25W	470	D17	DIODE	BAV21
R41	RESISTOR 1% 0.25W	5.6K	L1	INDUCTOR	0.1 H
R42	RESISTOR 1% 0.25W	5.6M	L2	INDUCTOR	0.1 H
R43	RESISTOR 1% 0.25W	3.9K	L3	INDUCTOR	8.2 H
R44	RESISTOR 1% 0.25W	5.6K	L4	INDUCTOR	8.2 H
R45	RESISTOR 1% 0.25W	10K	L5	INDUCTOR	8.2 H
R46	RESISTOR 1% 0.25W	3.9K	U1	INTEGRATED CIRCUIT	TL072
R47	RESISTOR 1% 0.25W	1K	U2	INTEGRATED CIRCUIT	TL072
P1	TRIMMER 10T	20K	U3	INTEGRATED CIRCUIT	TL072
P2	TRIMMER 10T	20K	U4	INTEGRATED CIRCUIT	TL072
P3	TRIMMER 10T	20K	U5	INTEGRATED CIRCUIT	TL072
P4	TRIMMER 10T	20K	U6	INTEGRATED CIRCUIT	TL082

U7 INTEGRATED CIRCUIT
U8 INTEGRATED CIRCUIT
Z1 JUMPER
Z2 JUMPER

TL082
TL072

Z3 JUMPER
J1 SHF 12 PIN CONNECTOR

Wiring diagram for “XLR” CANNON connectors, either for NALANCED or UNBALANCED configuration.

PIN 1	GND
PIN 2	+
PIN 3	-

BALANCED LINE

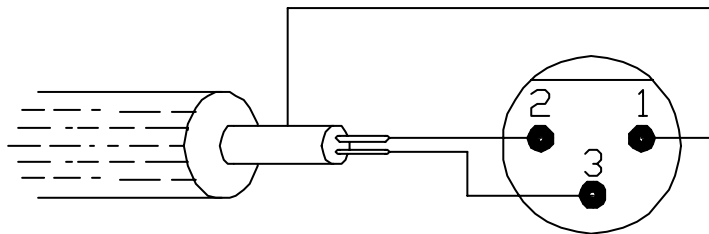

UNBALANCED LINE

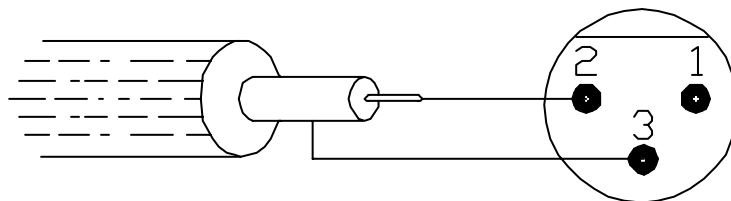

+

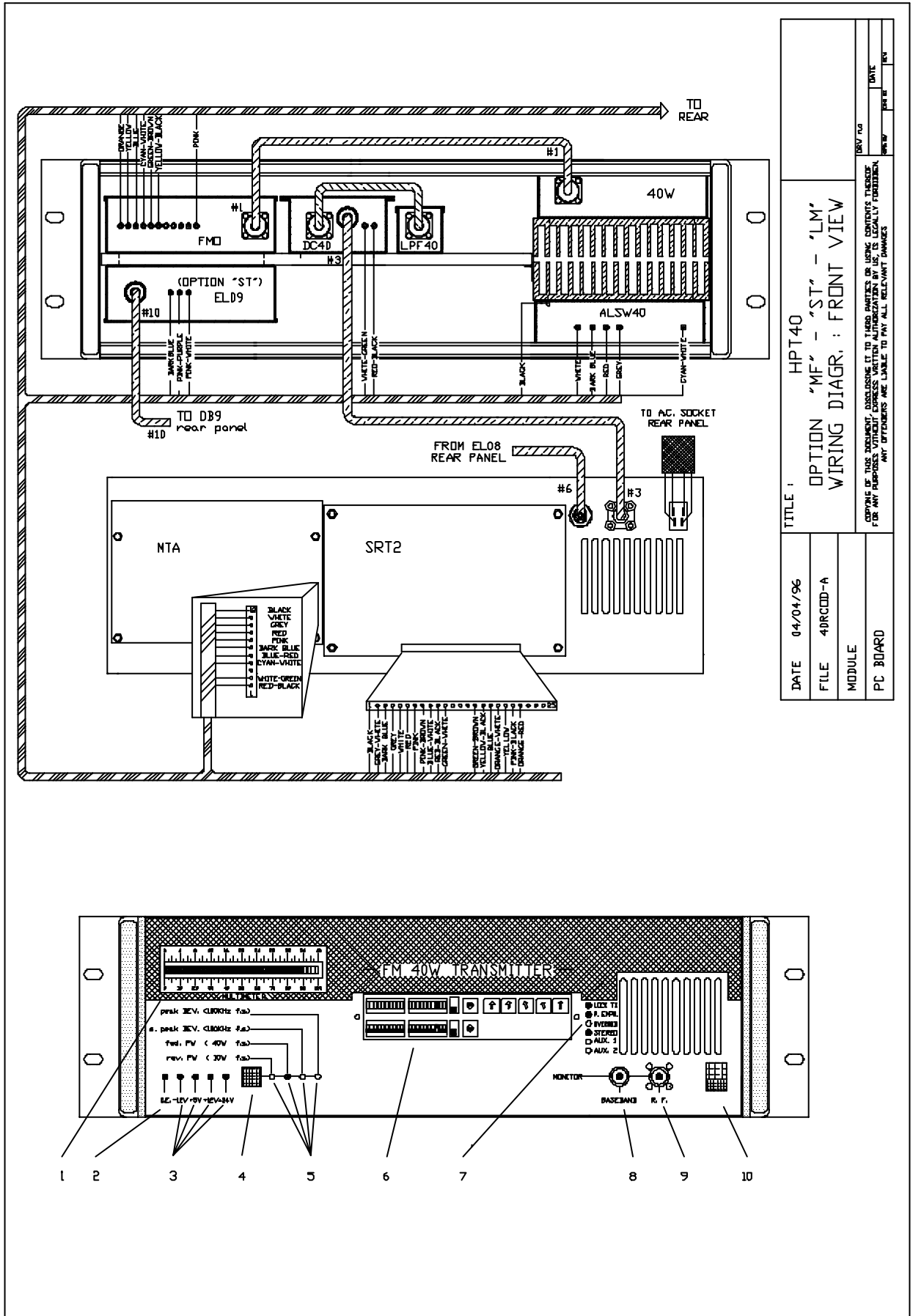

TITLE : HPT40		DATE 04/04/96	
OPTION "MF" - "ST" - "LM"		FILE 4DRCID-A	
WIRING DIAGR. : FRONT VIEW		MODULE	
COPYING OF THIS DOCUMENT, DISCLOSURE TO A THIRD PARTY OR USING CONTENTS THEREOF FOR ANY PURPOSES WITHOUT THE WRITTEN PERMISSION OF THE ORIGINAL AUTHOR, IS STRICTLY PROHIBITED. ANY OFFENDERS ARE LIABLE TO PAY ALL RELEVANT DAMAGES.		PC BOARD	
DRW. NO.	REV.	DATE	BY

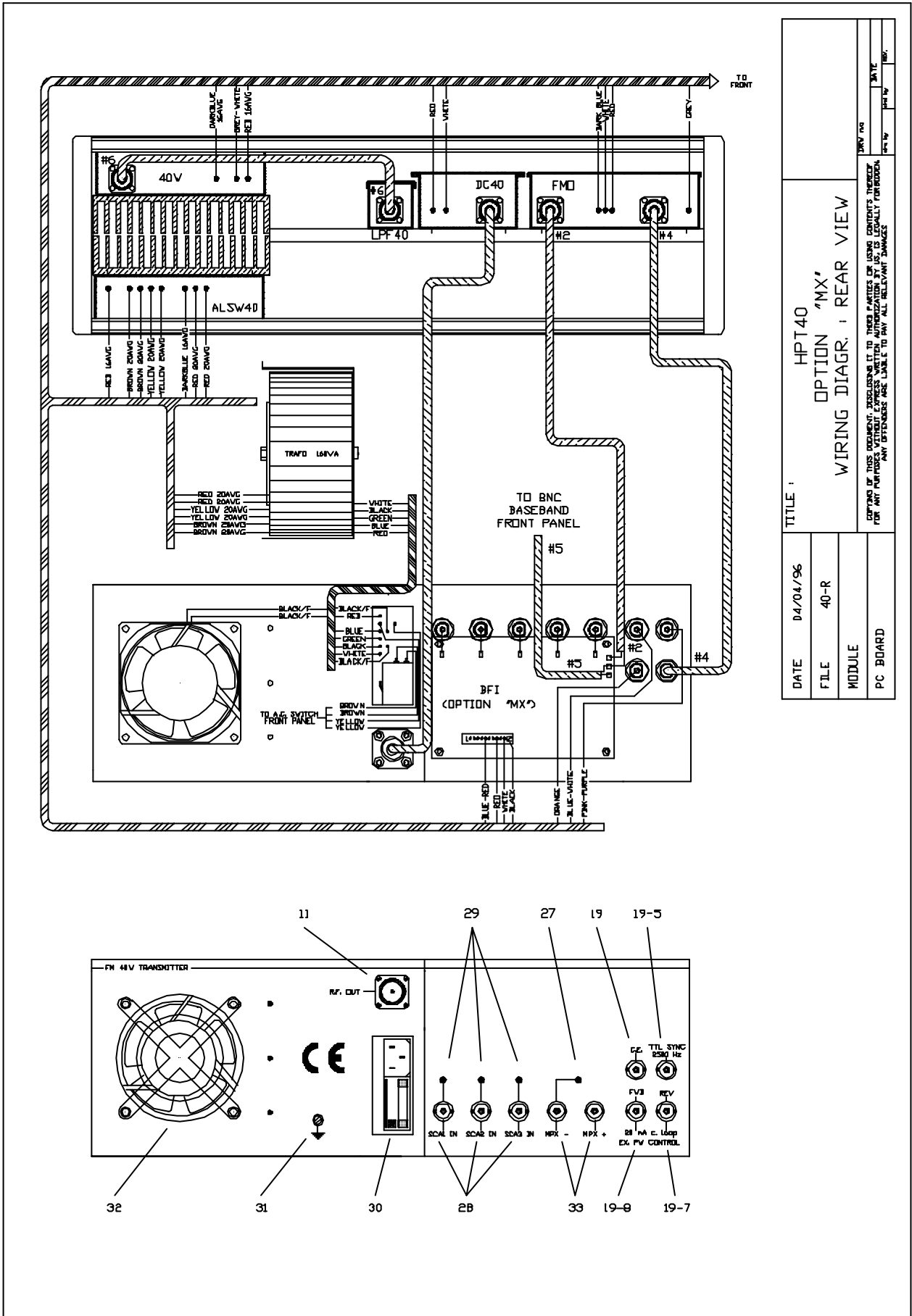

DATE 04/04/96		TITLE 1	
FILE 40-R		HPT40	
MODULE		OPTION 'MX'	
PC BOARD		WIRING DIAGR. 1 REAR VIEW	
<small> COMPANY OF THIS DOCUMENT, INCLUDING IT, THEIR PARTS OR USING CONTENTS THEREOF, FOR ANY PURPOSES ARE LIABLE TO PAY ALL RELEVANT DAMAGES. </small>			

PROCEDURES OF THE HPT40 ADJUSTMENTS

TEST EQUIPMENT DETAILS

<i>TYPE</i>	<i>PERFORMANCE</i>	<i>MODEL</i>	<i>MANUFACTURER</i>
Signal Generator	100 KHz - 1000 MHz	SMX	Rohde & Schwarz
Oscilloscope	DC - 60 MHz	PM 3050	Philips
Spectrum analyzer	50 Hz - 2.9 GHz	HP - 8560A	Hewlett Packard
Modulation Analyzer	50 KHz - 5.2 GHz	FMB	Rohde & Schwarz
Digital Multimeter	5 ½ digit	UDL44	Rohde & Schwarz
Attenuator	40 dB - 100 Watt	16-3763	Delta Ohm
Thru-line Wattmeter	50 - 125 MHz 5 Watt	43	Bird
RF Power Meter	10 MHz - 18 GHz	6950	Marconi Instruments

1 PRELIMINARY CHECK

- 1.1 These technical procedures must go with the fill of the ADJUSTMENT FORM
- 1.2 Please see the details written on the INPUT and QUALIFICATION FORMS
- 1.3 Make sure the voltage-switchover (located inside the AC socket on the rear panel) is set properly and that the fuse housed in the same socket is of the right value according to the AC voltage used (see the "PREFACE" chapter in this manual) and power up the equipment

2 ALSW40 POWER SUPPLY

- 2.1 Adj. R6 trimmer of ALSW40 to bring the voltage on the passing capacitor CP11 (Red wire) to the value of 12.5VDC
- 2.2 Adj. R21 trimmer of ALSW40 to bring the voltage on the passing capacitor CP10 to the value of 28VDC
- 2.3 Check the DC voltages on the grey, bleu and white wires, in order to have +5V, +24V, -12V
- 2.4 To stress by plastic screwdriver the soldering of ALSW40 board, and verify the correct fixing of the power transistor screws
- 2.5 To write these values on the ADJUSTMENT FORM

3 EL08 board - LIM C

- 3.1 Verify the requested Input Impedance (600 or 10Kohm) and consequently insert the J1, J2, J3 and J4 jumpers in correct position. Test the switches of the PRE-EMPHASIS and of the EXT-INT STEREO. Switch off the internal stereo coder and the Pre-emphasis, verify the position of the 1dB step Attenuator, located on the rear panel, normally adj. @ 0dB.
- 3.2 Insert an audio signal, from FMB Modulation Analyzer and with the same level highlight on the INPUT FORM, into LEFT input and to verify with AC multimeter the correct value, and balance, if necessary, the voltage drop due to Output Impedance of the Audio Generator. Connect the BASEBAND output to Oscilloscope and check the distortion @ 1KHz Audio Input Signal, and, if necessary, adj. R13 trimmer to have minimum distortion
 - 3.2.1 Set the Audio Signal Generator @ 19KHz and adj. L2 coil to minimum distortion
 - 3.2.2 Set the Audio Signal Generator @ 21.5KHz and adj. L3 coil to minimum distortion
 - 3.2.3 Set the Audio Signal Generator @ 1KHz, make a reference to 0dB_r, and adj. L1 coil in order to have the same value @ 15KHz
 - 3.2.4 Verify the ripple in 1KHz-15kHz band, no more than +/-0.15dB, refereed to 1KHz
 - 3.2.5 Set the Audio Signal Generator @ 15KHz and 20dB minus of the Nominal Audio Input (-14dBm is corresponding to 6dBm Nominal Audio Input), and adj. R13 & R17 for choice pre-emphasis value (50 or 75 S)
 - 3.2.6 Turn the pre-emphasis OFF and set the Audio Signal Generator @ 1KHz and Nominal Audio Input, and adj. R13 trimmer in order to have 1550 V rms to BASEBAND output

- 3.3 Repeat the procedures 3.2 for RIGHT channel, replacing these values
R14 with R40 L1 with L4
R17 with R44 L2 with L5
 L3 with L6
- 3.4 Set the Audio Signal Generator @ 1KHz and Nominal Audio Input into MPX audio input, and adj. R53 trimmer in order to have 1.550Vrms to BASEBAND output
- 3.5 Set the Audio Signal Generator @ 57KHz and Nominal Audio Input into SCA 1, 2, 3 audio inputs, and adj. R85, R92 and R98 trimmers in order to have 155mV rms to BASEBAND output (typical value)
- 3.6 Set the Audio Signal Generator @ 1KHz and Nominal Audio Input into MPX audio input, and adj. R110 trimmer in order to have 75KHz Deviation to BAR-GRAF multimeter
- 3.7 Set the Audio Signal Generator @ 1KHz and Nominal Audio Input into MPX audio input, and adj. R120 trimmer in order to have lighted the over-modulation led
- 3.8 Check by BASEBAND Output if the 1dB step Attenuator is working
- 3.9 With Deviation Limiter option, set the Audio Signal Generator @ 1KHz and Nominal Audio Input into LEFT audio input, and adj. RT1 trimmer of the LIM board in order to see the CLIPPER function on the Oscilloscope connected to BASEBAND Output
- 3.10 Stress by plastic screwdriver the soldering of EL08/1-2 and LIM C boards

4 STEREO CODER EL09

- 4.1 Insert an audio signal, from FMB Modulation Analyser set @ 1KHz and Nominal Audio Input into LEFT audio input, turn on the stereo coder by switch, connect the BASEBAND output to Oscilloscope and check the presence of MPX signal, adj. the C24 capacitor in order to synchronise the 19KHz sub-carrier with 1KHz envelope
- 4.2 Adj. R57 trimmer to get 2.8Vrms @ 19KHz on pin nr 7 of U14
- 4.3 Disconnect the audio input signal, connect the BASEBAND output to Oscilloscope and check the sub-carrier, adj. R36 trimmer for no offset
- 4.4 Adj. R12 trimmer to get 6V dc on R110
- 4.5 Disconnect the audio input signal, connect the BASEBAND output to FMB and check the 19KHz sub-carrier distortion value, better than 0.5%

4.6 Set the Audio Signal Generator @ 1KHz and Nominal Audio Input into LEFT+ audio input, and connect same signal into RIGHT-- and Oscilloscope External Trigger, connect the Oscilloscope CH1 input to BASEBAND output and check the presence of the double envelope, with superimposed the 19KHz pilot tone; optimise the cross-talk of the two envelopes and to make coincide Left cross-talk with Right cross-talk by R59 pilot tone phase trimmer

4.7 Set the Audio Signal Generator @ 1KHz and Nominal Audio Input into LEFT audio input, and connect BASEBAND output to STEREO DECODER; check the Left&Right separation. For improve the separation adj R30 trimmer in order to get 70dB or better. If necessary, add a suitable capacitor (typ 330 pF-1800 pF), in parallel to C43 capacitor, by the C10 & C42 free holes (components not mounted)

4.8 Repeat the 4.7 procedure for RIGHT audio input, and act on the R59 and R30 trimmers in order to have better Separation in the 87.5-108MHz band and both audio channels

4.9 Check the Vpp of the MPX signal, with nominal audio input, and act on the R70 trimmer to have 1.1Vpp value; therefore turn off the nominal audio input and to measure the subcarrier value, acting on the R36 trimmer to have 110mVpp value

4.10 Set the Audio Signal Generator @ 1KHz and Nominal Audio Input into LEFT audio input, and check the distortion of the decoded MPX, and optimize the distortion by R12 trimmer (typ. <0.02%)

4.11 Set the Audio Signal Generator @ 15KHz and Nominal Audio Input into LEFT+ audio input, and connect same signal into RIGHT--; in this way you transmit the stereo information only, and this condition represents the very worst event for engaged base band and out band spurious emission.

Connect the Spectrum Analyzer to BASEBAND output, through Oscilloscope Probe, set @ x1
Adj the pilot subcarrier at - 21dB, and check in 0-53 KHz band the presence of two lines with -7dB @ 23KHz and 53KHz

Check the 38KHz suppression (typ 65dB), the line at 15KHz (typ. 50dB), and if necessary adj. very fine the audio input level (left or right) and/or the L1 or L4 coil composing the 15KHz Low Pass Filter.

Moreover to check the response of the out band spurious in the 53-200KHz band (<65dB) and in the 200-1000KHz band (<70dB)

4.12 Stress by plastic screwdriver the soldering of the board

5 VCO module FMO

5.1 Disconnect the audio input cable from input BNC connector (BF-IN), adj the voltage value in order to have 3.16Vdc on the 1 pin of the U6 (corresponding to crystal temperature =50°C)

5.2 After setting the rotary switches @ 100MHz, connect the OUT-VCO connector to S.ANALYZER, in order to check the spurious emission, with CENTER FREQUENCY=100MHz, SPAN=100MHz, REF LEVEL=20dBm. Turn off and turn on the exciter and to check at the S.A. the 100 MHz signal =10-12dBm

5.3 Connect the OUT-VCO connector to MODULATION ANALYZER, in order to check residual noise value lower than 9Hz (CCIR filter inserted)

5.4 Turn C36 capacitor to have the precision frequency 100MHz +/-100Hz

5.5 Reconnect the audio input cable from input BNC connector (BF-IN), turn off the Pre-emphasis by switch, turn off the stereo coder by switch, set the Audio Signal Generator @ 1KHz and Nominal Audio Input into LEFT audio input, adj the deviation at 75KHz by RT1 trimmer. Change the transmitter frequency in the range 87.5-108MHz and verify the range (included +/-1dB). If necessary adj RT1 trimmer

5.6 Stress by plastic screwdriver the soldering and mechanical parts of the board

6 RF AMPLIFIER MODULE AND ACCESSORIES (DC40, 40W and SRT boards)

6.1 Disconnect the RF input cable from the 40W module, set in ON position the dip-switches nr 10 and 20 of the MAX SET OUTPUT POWER SWITCHES, located on the EL10 Front Panel board

6.2 Turn anti-clockwise the two trimmers RT1 and RT3 of the Directional Coupler; cancel the output offset on CP1 and CP2, by acting on RT2 and RT4

6.3 Act on the R10 trimmer (40W module) to have 0.35V drop in parallel to 1 ohm R8 resistor, corresponding $I_{driver} = 350mA$

6.4 Act on the R17 trimmer (40W module) to have 0.33V drop in parallel to 0.33 ohm R13 resistor, corresponding $I_{final} = 1A$

6.5 Connect a 50W Dummy Load, a 40dB attenuator, a reflected PWR Wattmeter, a Bolometer, in serie to RF Output of Transmitter; set the RF Signal Generator @ 98MHz and 12dBm output, connect the RF signal generator to RF-IN of the 40W module; turn clockwise RT1 and RT2 trimmer (SRT board), to have 40W output power

6.6 Set the RF Signal Generator @ 88MHz and 108MHz, to have 40W output power; if necessary, modify L13 coil dimension or adj the bias of the driver transistor and final transistor

6.7 Set the RF Signal Generator @ 100MHz and turn anti-clockwise RT2 trimmer of the SRT board to decrease the output power till to reach 20W or similar on the panel Wattmeter; the Bolometer will read a value lower than 40W; now adj L4 coil (DC40 module) to have same Bolometer reading in the range 88-98-108MHz; now set the RF Signal Generator @ 98MHz and act on the trimmer RT2 (DC40 module) to have 20W or similar on the Bolometer reading

6.8 Set in OFF position the dip-switches nr 20 of the MAX SET OUTPUT POWER SWITCHES, located on the SRT Front Panel board (so is set 20W O.P.); turn the Directed Power Trimmer to the full

scale (clockwise); the Bolometer will read a PWR value higher than 20W; now adj RT3 trimmer to have 20W on the Bolometer reading

6.9 Set different MAXIMUM OUTPUT POWERS by selected the MAX SET OUTPUT POWER SWITCHES, and verify the correct reading

6.10 Turn the RT1 trimmer (SRT board) of the reflected power completely anti-clockwise; disconnect the Dummy Load, and reading the PWR of the reflected PWR Wattmeter, turn the RT1 trimmer (SRT board) of the reflected power to have 4W reading on the exciter leds-bar; set the RF Signal Generator @ 88-98-108MHz and modify L13 coil dimension (DC40) to have a constant value on the reflected PWR Wattmeter; set the RF Signal Generator @ 98MHz and adj RT2 trimmer (DC40 module) to have 4 W reading on the exciter leds-bar

6.11 Stress by plastic screwdriver the soldering and mechanical parts of the board, and fill in the ADJUSTMENT FORM

7 **BFI board**

7.1 Verify the requested Input Impedance (600 or 10Kohm) and consequently insert the Z1 and Z2 jumpers in correct position, for MPX input

7.2 Insert Z3 Pre-emphasis Jumper in ON position; set the Audio Signal Generator @ 15KHz and minus -20dBm, into MPX input; connect the Output Monitor to MODULATION ANALYZER, adj P5 trimmer to have a value difference of the 13.67dB from Pre-emphasis ON and OFF (16.84dB for FCC)

7.3 Disconnect the Pre-emphasis, set the Audio Signal Generator @ 1KHz and Nominal Audio Input into MPX+ audio input; adj P1 trimmer, located next to MPX+ audio input connector, to read 1550mV rms on the Modulation Analyzer. Same procedure and final result for MPX- audio input

7.4 Set the Audio Signal Generator @ 57KHz and Nominal Audio Input into SCA1 audio input; adj P2 trimmer, located next to SCA1 audio input connector, to read a correct ratio with previous MPX output on the Modulation Analyzer

7.5 Repeat the procedures 7.4 for SCA2 audio input, adj P3 trimmer

7.6 Repeat the procedures 7.4 for SCA3 audio input, adj P4 trimmer

7.7 Set the Audio Signal Generator @ 1KHz and Nominal Audio Input into MPX+ audio input; adj P6 trimmer (BFI board) to read 75KHz deviation on the exciter leds-bar

PROCEDURES OF THE ELC40 TEST

TEST EQUIPMENT DETAILS

<i>TYPE</i>	<i>PERFORMANCE</i>	<i>MODEL</i>	<i>MANUFACTURER</i>
Spectrum Analyzer	9 KHz - 26.5 Ghz	HP-8563E	Hewlett Packard
Signal Generator	100 KHz - 1000 Mhz	SMG	Rohde & Schwarz
Audio Analyzer	10 hz - 100 KHz	UPA	Rohde & schwarz
Multifunction Synthesizer	DC - 600 KHz	HP - 8904-A	Hewlett Packard
Oscilloscope	DC - 60 Mhz	PM-3050	Philips
Digital Multimeter	6 ½ digit	8840-A	Fluke
Modulation Analyzer	55 KHz - 1360 Mhz	FAM	Rohde & Schwarz
Stereo monitor decoder	20 hz - 15 KHz	FMS - 2	Belar
Stereo Coder	40 hz - 15 KHz	MSC2	Rohde & Schwarz
Stereo Decoder	40 hz - 15 khz	MSDC2	Rohde & Schwarz
Thru-line Wattmeter	50 - 200 Mhz	Model 4412	Bird
Coaxial Resistor	50 ohm - 500 Watt	Model 8201	Bird

1 PRELIMINARY COMMENT

1.1 This technical procedures must to go with the fill of the TEST FORM

1.2 The TEST of the HPT40 exciter must to be realized by different engineering (no ADJUSTEMENT technician) and different Test Equipment

1.3 Before realise the TEST verify the ADJUSTEMENT, INPUT and QUALIFICATION FORMS, in order to note the possible previous faults indicated from previous technicals, or customer request

2 ALSW40 POWER SUPPLY

2.1 Connect a 50W Dummy Load in serie to RF Output of Transmitter; and TURN ON the exciter set @ 100MHz, maximum RF POWER

2.2 Check the DC voltages, on the output wires, with following tollerance:

VOLTAGE (V)	+ max (V)	- max (V)	ripple (mV)	colour
-12	1	1	< 5	white
+5	0.2	0.2	< 5	grey
+12.5	0.5	0.5	< 8	red
+24	1	1	< 5	bleu
+28	0.1	0.5	< 60	red-big

2.3 Stress by plastic screwdriver the soldering of ALSW40 board, and verify the correct fixing of the power transistor screws

3 EL08 board - LIM C

3.1 Set the UPA Modulation Analyzer @ Nominal Audio Input into LEFT input and verify with AC multimeter the correct value, and to balance, if necessary, the voltage drop due to Output Impedance of the Audio Generator, take off the Pre-emphasis and to switch off the internal stereo coder, verify the position of the 1dB step Attenuator, located on the rear panel, normally adj. @ 0dB

3.2 Set the UPA Mod. Analyzer @ 1KHz and verify from BASEBAND output the level =+6dBm 01dB

3.3 Verify the ripple in 1KHz-15KHz band, lower than 0.15dB, referred to 1KHz

3.4 Verify the out band attenuation >45dB in the range 19KHz-53KHz

3.5 Set the Audio Signal Generator @ 15KHz and 20dB minus of the Nominal Audio Input (-14dBm is corresponding to 6dBm Nominal Audio Input), and verify the correct Pre-emphasis Response (13.67dB for 50uS and 16.84dB for 75uS)

3.6 Repeat the procedures 3.2, 3.3, 3.4, 3.5 for RIGHT audio input

3.7 Switch off the Pre-emphasis

3.8 Check the requested Input Impedance

3.9 Check the light up of the OVERMODULATION LED, with 0.5dB of the Audio Input Variation

3.10 Set the Audio Signal Generator @ Nominal Audio Input into MPX audio input, and verify the correct value =1550mVrms 0.1dB to BASEBAND output

3.11 Set the Audio Signal Generator @ 57KHz and Nominal Audio Input into SCA 1, 2, 3 audio inputs, and verify the value =155mVrms to BASEBAND output (typical value)

4 EL09 STEREO CODER TEST

4.1 Switch ON the internal stereo coder, and verify on the BASEBAND output the 19KHz sub-carrier level (-14 17dBm). Typically is -14dBm or 155mVrms

4.2 Verify the 19KHz sub-carrier distortion, better than 0.5% (value proportional to 38KHz suppression)

4.3 Set the Audio Signal Generator @ 1KHz and Nominal Audio Input into LEFT audio input, and check the Stereo Separation on the BELAR Stereo monitor

4.4 Repeat the procedure 4.3 for RIGHT audio channel

4.5 Extend the previous measure in the audio range 40Hz, 300Hz, 1KHz, 5KHz, 15KHz for LEFT and RIGHT audio channel, with Pre-emphasis (Exciter) and De-emphasis (BELAR Stereo monitor) OFF

4.6 Repeat the previous procedure with the MSDC2 Rohde Schwarz Stereo Decoder, and verify the results better than 60dB; if necessary adj the Stereo Decoder Equipment with the same phase, through the HP multifunction Synthesizer; if necessary, adj the 19KHz pilot phase (EL09 module)

4.7 Set the UPA Audio Analyzer @ 1KHz and Nominal Audio Input into LEFT audio input, and connect the BELAR Decoder to BASEBAND output; take the Belar Decoded and De-emphasis Output into UPA Audio Analyzer, and check the distortion better than 0.03%

4.8 Connect RF EXCITER PROBE at FAM RF INPUT, take FAM REAR MPX OUTPUT and connect it at BELAR Decoder; in this condition repeat the procedures 4.3, 4.4, 4.5 and verify the stereo-separation better than 48dB (this value is the limit for this test equipment)

4.9 Hold the test equipment how previous procedure, connect the Belar Decoded and De-emphasis Output into UPA Audio Analyzer, check the S/N with 300Hz audio signal and nominal audio input, make a reference at 0dB_r, disconnect the audio input and read the result on the UPA equipment better than 80dB

4.10 Repeat the 4.9 procedure, taking the BASEBAND monitor instead of FAM REAR MPX OUTPUT, and read the result better than 85dB

4.11 Stress by plastic screwdriver the soldering of EL09 board

5 FMO module (VCO Oscillator)

5.1 Check that the voltage on the pin nr 1 of the U6 is $3.16V \pm 0.01V$; touch with finger the crystal case in order to verify the tolerant temperature ($50^{\circ}C$); in fact any problem in this circuit bring the temperature at two possible values, ambient temperature or $70^{\circ}C$

5.2 Set the front panel rotary-switches @ customer frequency or 100MHz, connect RF probe to FAM, and check the frequency precision (100Hz tolerance)

5.3 In this condition, check the Residual Noise value in the range indicate from the TEST FORM, value lower than 5Hz in the range 30Hz-20KHz; check the S/N weighted (CCIR option), value better than 77dB, referred at 75KHz and De-emphasis off

5.4 Connect the VCO output to Spectrum Analyzer, and check the amplitude, included in the range 10 13dBm

5.5 Set the front panel rotary-switches @ 88 MHz, check that the voltage on the pin nr 1 of the U4 is higher than 3V

5.6 Set the front panel rotary-switches @ 108MHz, check that the voltage on the pin nr 1 of the U4 is higher than 10V

5.7 Set the front panel rotary-switches @ frequencies displayed on the TEST FORM, with set the following parameters: MONO mode, 1KHz Audio Signal and nominal audio input; check that the frequency deviation is 75KHz $\pm 1dB$

5.8 In the previous condition, check that the DISTORTION is better than 0.03%

5.9 Stress by plastic screwdriver the soldering of the VCO module; check also the microphonique quality

6 OUTPUT POWER

6.1 Set the front panel rotary-switches @ 87.5MHz, set in ON position the dip-switches nr 10 and 20 of the MAX SET OUTPUT POWER SWITCHES, located on the SRT Front Panel board; the RF Output Power will reading higher than 38W (with the Direct PWR trimmer to the full scale, clockwise); check now on the S.Analyzer that the second Harmonic is better than 70dBc (attention to saturation of the S. Analyzer RF input)

6.2 Set now in OFF position the dip-switch nr 20 of the MAX SET OUTPUT POWER SWITCHES (so is set 20W O.P.); the Output Power will reading 20 W $\pm 1W$

6.3 Disconnect the Dummy Load, and read than the Reflected Power is 4W $\pm 1W$. Check on the Spectrum Analyzer the Spurious presence (due to Final Stage instability)

- 6.4 Repeat the procedures nr 6.1, 6.2 and 6.3 for 98MHz Output Frequency
- 6.5 Repeat the procedures nr 6.1, 6.2 and 6.3 for 108MHz Output Frequency
- 6.6 Check the RF coaxial cables and respective RF connectors, and stress by plastic screwdriver the solderings

7 **AUDIO FREQUENCY (BFI board)**

- 7.1 Read the Customer request, regarding the MPX Input Impedance (600 or 10Kohm) and consequently insert the Z1 and Z2 jumpers in correct position
- 7.2 Insert Z3 Pre-emphasis Jumper in ON position; set the Audio Signal Generator @ 15KHz and minus -20dBm, into MPX+ input; connect the Output Monitor to MODULATION ANALYZER and check that the value difference is 13.67dB from Pre-emphasis ON and OFF (16.84dB for FCC)
- 7.3 Disconnect the Pre-emphasis, set the Audio Signal Generator @ 1KHz and Nominal Audio Input into MPX+ audio input; check that the Output monitor is 1550mVrms
- 7.4 Set the Audio Signal Generator @ 57KHz and Nominal Audio Input into SCA1 audio input; check that there is a correct ratio between MPX and SCA
- 7.5 Repeat the procedures 7.4 for SCA2 audio input
- 7.6 Repeat the procedures 7.4 for SCA3 audio input
- 7.7 Set the Audio Signal Generator @ 1KHz and Nominal Audio Input into MPX+ audio input; check that the exciter leds-bar are reading 75KHz deviation