

8 7 6 5 4 3 2 1

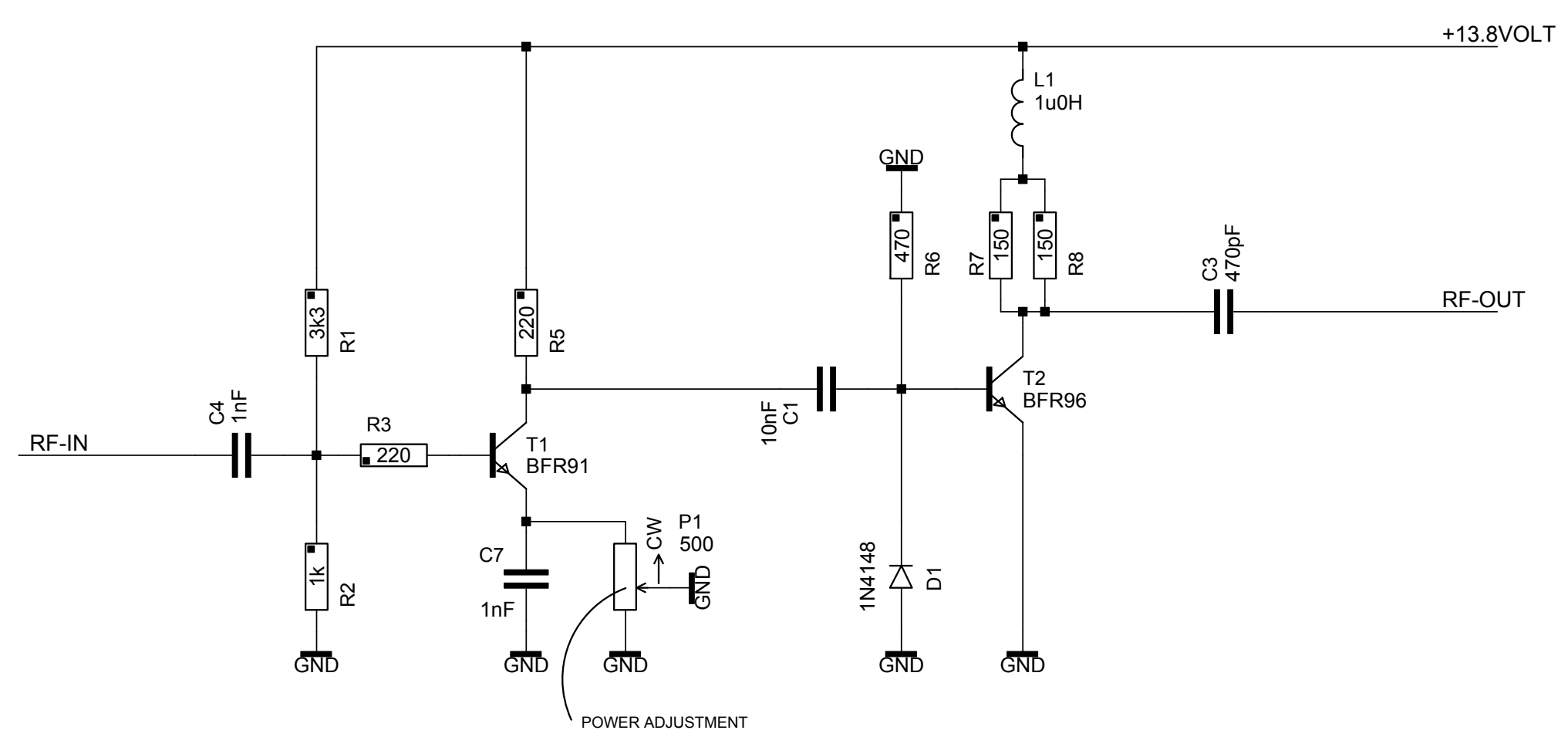

COMPONENT SPECIFICATION (UNLESS OTHERWISE SPECIFIED)				PROJECT :	
1) RESISTOR VALUES IN OHMS, 5%, 0,25W				REMARKS :	
2) CAPACITOR VALUES IN MICROFARADS.				DESCRIPTION :	
3) ALL DECOUPLING CAPACITORS IN THIS DESIGN ARE CERAMIC MONOLITICH EPOXY DIPPED				AMPLIFIER WITH THE BFR91 / BFR96	
				DATE	NAME
				DESIGN	H.SLOT
				CHECKED	
				SHEET NAME :	
				: 28-05-2006	
				FILE	AMPLIFIER 10 MWATT - 300 MWATT REV A
					PAGE 1 V 1
A	CHANGES ONLY BY CAD	H.SLOT	26-05-2006		OF
REV	REMARKED	NAME	DATE		

8 7 6 5 4 3 2 1